

EC²



low profile

T²L

COMPATIBLE

MANCHESTER DECODER MODULE

- T²L input and outputs
- Stable and precise
- 28-pin DIP package (.320 high)
- Available in data rates from 2 to 25 Mhz
- Fast rise time on outputs
- 10 T²L fan-out capacity

design notes

The "DIP Series" Manchester Decoder Modules developed by Engineered Components Company have been designed to accept a T²L Manchester encoded data stream at a given bit rate and output the recovered clock and the original data. These modules accept input data streams with standard T²L levels and present a two (2) fan-in at the input. Manchester data with a rising edge in the center of the bit period will be interpreted as "1" and will result in a high (1) output. Manchester data with a falling edge in the center of the bit period will cause a low "0" at the output. Minor edge skewing in the transmission channel will be tolerated without producing output errors. Skewing should not be more than that which would change the duty cycle of a 50%

duty cycle square wave at the bit rate with standard frequencies by more than 6%. These modules have a capability of driving up to 10 T²L Schottky loads at each output.

These Manchester Decoder Modules are contained in a 28-pin DIP package compatible with Schottky T²L and DTL circuits. These modules are of hybrid construction utilizing the proven technologies of active integrated circuitry and of passive networks utilizing capacitive, inductive and resistive elements. The ICs utilized in these modules are burned-in to Level B of MIL-STD-883 to ensure a high MTBF. The MTBF on these modules, when calculated per MIL-HDBK-217 for a 50°C ground fixed environment, is in excess of 1 million hours.

The TTLMDM is offered in 28 variations constructed to decode Manchester encoded data at specific bit rates from 2 to 25 Mhz. These modules will decode input frequency errors of ±5% with no significant effect on the output error rate.

These "DIP" modules are packaged in a 28-pin DIP housing, molded of flame-proof Diallyl Phthalate per MIL-M-14, Type SDG-F, and are fully encapsulated in epoxy resin. Leads meet the solderability requirements of MIL-STD-202, Method 208. Corner standoffs on the housing provide positive standoff from the printed circuit board to permit solder-fillet formation and flush cleaning of solder-flux residues for improved reliability.

EC²

engineered components company

3580 Sacramento Drive, P. O. Box 8121, San Luis Obispo, CA 93403-8121

Phone: (805) 544-3800

DESIGN NOTES (continued)

Marking consists of manufacturer's name, logo (EC²), part number, terminal identification and date code of manufacture. All marking is applied by silk screen process using white epoxy paint in accordance with MIL-STD-130, to meet the permanency of identification required by MIL-STD-202, Method 215.

BLOCK DIAGRAM IS SHOWN BELOW

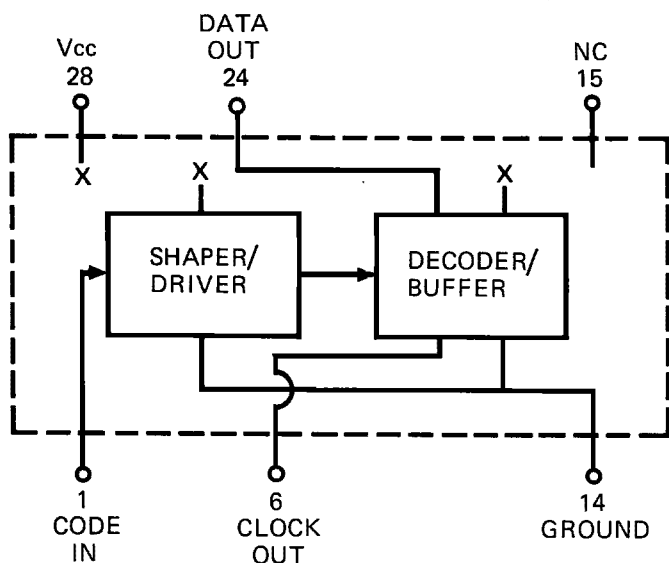

MECHANICAL DETAIL IS SHOWN BELOW

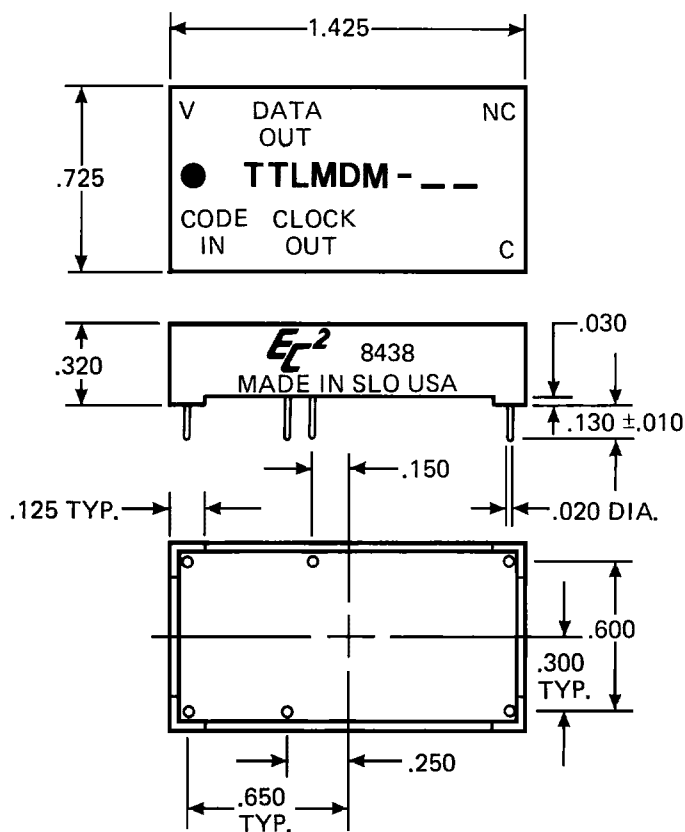

TEST CONDITIONS

1. All measurements are made at 25°C.
2. V_{CC} supply voltage is maintained at 5.0V DC.
3. All units are tested using a Schottky toggle-type source and one Schottky T²L load at the output being tested.
4. Input signal used is a Manchester data stream at the nominal bit rate and with no duty cycle skewing.

OPERATING SPECIFICATIONS

V_{CC} supply voltage: 4.75 to 5.25V DC

V_{CC} supply current: 225ma typical

Logic 1 input:

Voltage 2V min.; 5.5V max.

Current 2.4V = 100ua max.

5.5V = 2ma max.

Logic 0 input:

Voltage8V max.

Current -4ma max.

Logic 1 Voltage out: 2.4V min.

Logic 0 Voltage out:4V max.

Operating temperature range: 0 to +70°C.

Storage temperature: -55 to +125°C.

PART NUMBER TABLE

Part Number	Output Frequency	Part Number	Output Frequency
TTLMDM-2	2 Mhz	TTLMDM-12	12 Mhz
TTLMDM-2.5	2.5 Mhz	TTLMDM-13	13 Mhz
TTLMDM-3	3 Mhz	TTLMDM-14	14 Mhz
TTLMDM-3.5	3.5 Mhz	TTLMDM-15	15 Mhz
TTLMDM-4	4 Mhz	TTLMDM-16	16 Mhz
TTLMDM-4.5	4.5 Mhz	TTLMDM-17	17 Mhz
TTLMDM-5	5 Mhz	TTLMDM-18	18 Mhz
TTLMDM-5.5	5.5 Mhz	TTLMDM-19	19 Mhz
TTLMDM-6	6 Mhz	TTLMDM-20	20 Mhz
TTLMDM-7	7 Mhz	TTLMDM-21	21 Mhz
TTLMDM-8	8 Mhz	TTLMDM-22	22 Mhz
TTLMDM-9	9 Mhz	TTLMDM-23	23 Mhz
TTLMDM-10	10 Mhz	TTLMDM-24	24 Mhz
TTLMDM-11	11 Mhz	TTLMDM-25	25 Mhz

Special modules can be readily manufactured to improve tolerances and/or provide customer specified random data rates for specific applications.