

AN5138NK

Video IF Amplifier, PLL Detector, AGC, AFC, SIF IC for Color TV

■ Overview

The AN5138NK is an integrated circuit designed for video-IF and audio-IF processing circuits, in color TV and VCR.

■ Features

- By adopting built-in VCO PLL-type video-detector circuit, the high performance IC-detector system can be realized for sound multiplex and tele-text broadcasting.
- Quadrature sound FM detector built-in.
- Frequency characteristics compensation pin (Pin20)
VCR-switch pin (Pin5)
- Sound-output level-adjustment pin (Pin25)

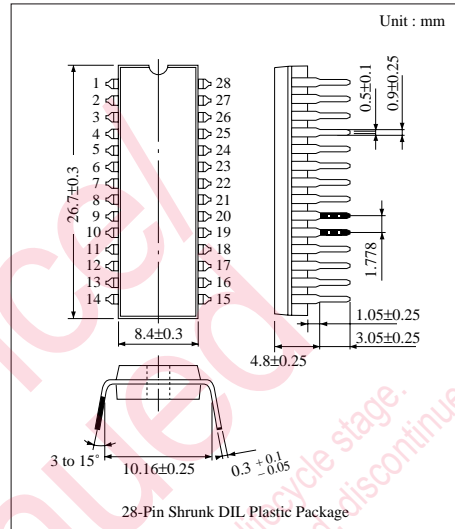

■ Block Diagram

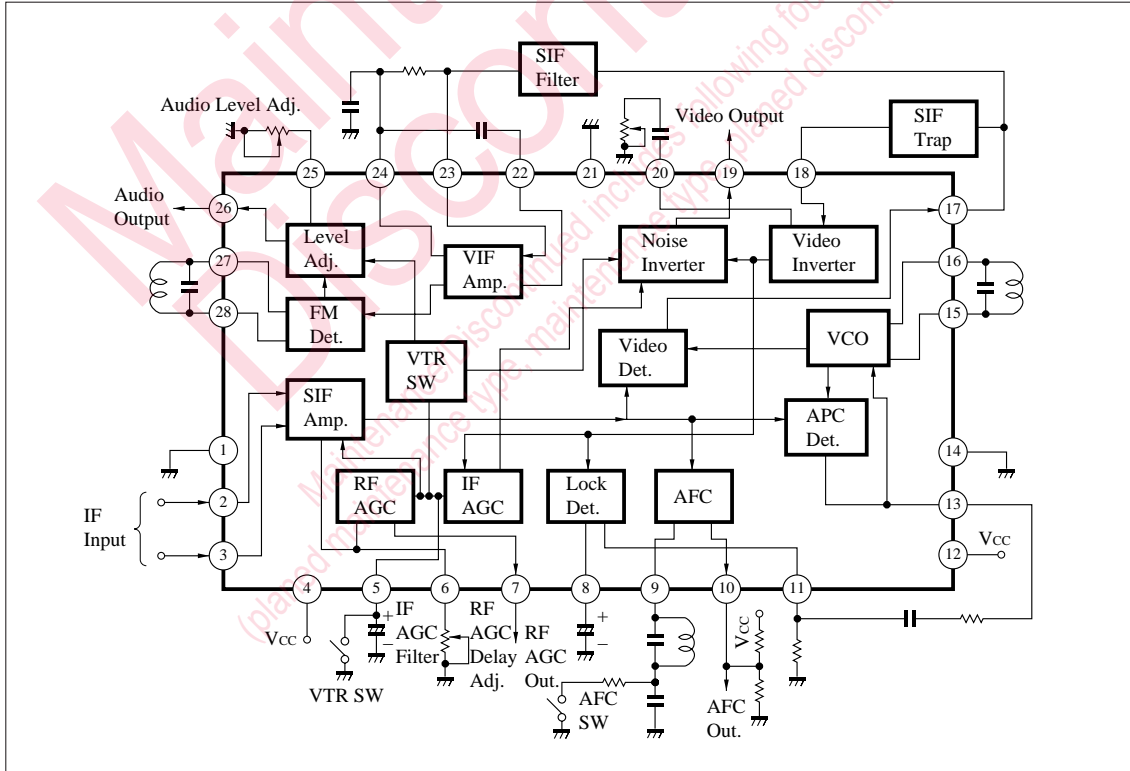

■ Absolute Maximum Ratings (Ta=25°C)

Parameter		Symbol	Rating		Unit
Voltage	Supply Voltage	V _{CC}	13.8		V
	Circuit Voltage	V _{5-1, 14, 21}	V _{4, 12-1, 14, 21}	0	V
		V _{6-1, 14, 21}	V _{4, 12-1, 14, 21}	0	V
		V _{7-1, 14, 21}	V _{4, 12-1, 14, 21}	0	V
		V _{10-1, 14, 21}	V _{4, 12-1, 14, 21}	0	V
		V _{18-1, 14, 21}	V _{4, 12-1, 14, 21}	0	V
	V _{25-1, 14, 21}	8.0	0	V	
Current	Circuit Current	I ₁₇	-7	+0.5	mA
		I ₁₉	-7	+0.5	mA
		I ₂₆	-5	+0.5	mA
Power Dissipation (Ta=70°C)		P _D	1,300		mW
Temperature	Operating Ambient Temperature	T _{opr}	-20 to +70		°C
	Storage Temperature	T _{stg}	-55 to +150		°C

■ Electrical Characteristics (V_{CC}=12V, Ta=25°C)

Parameter	Symbol	Condition	min	typ	max	Unit
IF Amplifier · Detection · AGC · AFC Circuit						
Video detector output	V _O	f = 58.75MHz, V _i = 80dBμ, m = 87.5%	1.9	2.2	2.5	V _{P-P}
Input sensitivity	S _(IN)	V _O = -3dB	49	53	57	dBμ
Max. allowable input	V _{1(max)}		103	108	—	dBμ
Differential gain	DG	f = 58.75MHz, V _i = 80dBμ, m = 87.5%	—	2	6	%
Differential phase	DP	f = 58.75MHz, V _i = 80dBμ, m = 87.5%	—	2	5	deg
Frequency characteristics	f _c	V _O = -3dB	5.5	6.5	7.5	MHz
RF AGC gain	G _{RFAGC}	f = 10kHz, V _i = 10mV	40	44	48	dB
AFC phase det. sensitivity	μ	R _L = 68kΩ/82kΩ	30	45	60	mV/kHz
AFC center voltage	V ₁₀	R _L = 68kΩ/82kΩ	4.2	6.5	8.2	V
VCO · APC Circuit						
VCO max. variable range (1)	Δf _{V(1)}	V ₁₃ = 2V	0.8	1.5	2.5	MHz
VCO max. variable range (2)	Δf _{V(2)}	V ₁₃ = 3V	-3.4	-2.4	-1.4	MHz
VCO control sensitivity	β		3	4.5	6	kHz/mV
APC pull-in range (1)	f _{APC(1)}		+0.85	+1.5	+2.5	MHz
APC pull-in range (2)	f _{APC(2)}		-3.5	-2.5	-1.6	MHz
SIF Circuit						
Total detector output	V _O	f _o = 4.5MHz, f _m = 400Hz Δf = ±25kHz, V _i = 100dBμ	490	620	950	mV _{rms}
Input limiting voltage	V _{i(lim)}	f _o = 4.5MHz, f _m = 400Hz Δf = ±25kHz, V _i = 100dBμ	—	42	47	dBμ
DC Characteristics						
Circuit current	I ₄ + I ₁₂		50	70	90	mA

Request for your special attention and precautions in using the technical information and semiconductors described in this book

- (1) If any of the products or technical information described in this book is to be exported or provided to non-residents, the laws and regulations of the exporting country, especially, those with regard to security export control, must be observed.
- (2) The technical information described in this book is intended only to show the main characteristics and application circuit examples of the products, and no license is granted under any intellectual property right or other right owned by our company or any other company. Therefore, no responsibility is assumed by our company as to the infringement upon any such right owned by any other company which may arise as a result of the use of technical information described in this book.
- (3) The products described in this book are intended to be used for standard applications or general electronic equipment (such as office equipment, communications equipment, measuring instruments and household appliances).
Consult our sales staff in advance for information on the following applications:
 - Special applications (such as for airplanes, aerospace, automobiles, traffic control equipment, combustion equipment, life support systems and safety devices) in which exceptional quality and reliability are required, or if the failure or malfunction of the products may directly jeopardize life or harm the human body.
 - Any applications other than the standard applications intended.
- (4) The products and product specifications described in this book are subject to change without notice for modification and/or improvement. At the final stage of your design, purchasing, or use of the products, therefore, ask for the most up-to-date Product Standards in advance to make sure that the latest specifications satisfy your requirements.
- (5) When designing your equipment, comply with the range of absolute maximum rating and the guaranteed operating conditions (operating power supply voltage and operating environment etc.). Especially, please be careful not to exceed the range of absolute maximum rating on the transient state, such as power-on, power-off and mode-switching. Otherwise, we will not be liable for any defect which may arise later in your equipment.
 - Even when the products are used within the guaranteed values, take into the consideration of incidence of break down and failure mode, possible to occur to semiconductor products. Measures on the systems such as redundant design, arresting the spread of fire or preventing glitch are recommended in order to prevent physical injury, fire, social damages, for example, by using the products.
- (6) Comply with the instructions for use in order to prevent breakdown and characteristics change due to external factors (ESD, EOS, thermal stress and mechanical stress) at the time of handling, mounting or at customer's process. When using products for which damp-proof packing is required, satisfy the conditions, such as shelf life and the elapsed time since first opening the packages.
- (7) This book may be not reprinted or reproduced whether wholly or partially, without the prior written permission of Matsushita Electric Industrial Co., Ltd.