



WIDE BANDWIDTH, VERY HIGH VOLTAGE CRT VIDEO AMPLIFIER

641

M.S.KENNEDY CORP.

4707 Dey Road Liverpool, N.Y. 13088

(315) 701-6751

FEATURES:

- Pin Compatible with LH3424 and CR3424 High-Rel Versions
- 2.5nS Transition Times
- Drives 8.5pF Capacitive Load With Ease
- DC Coupled for Output Level Adjust
- 175MHz Bandwidth
- 70Vpp Output Swing
- Contact MSK for MIL-PRF-38534 Qualification Status

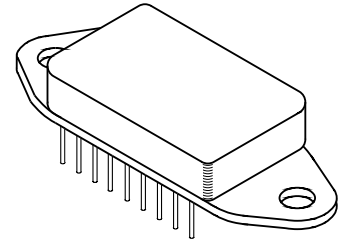

DESCRIPTION:

The MSK 641 is a wide bandwidth, high voltage color or monochrome CRT video amplifier designed specifically to drive the cathode of today's most demanding high resolution CRT monitors. The MSK 641 is a transimpedance amplifier capable of achieving a  $\pm 35V$  output voltage swing with an input current of  $\pm 10mA$ . The output of the amplifier is DC biased at half the power supply voltage. Transition times in the range of 2.5nS enable the MSK 641 to drive 10nS pixels with ease and make it ideally suited for monitors with 1280 x 1024 or higher display resolutions. The 9 pin single in-line bathtub package is pin for pin compatible with the LH3424 and CR3424 and is a replacement for the high-rel versions of these devices with improved stability and thermal performance.

EQUIVALENT SCHEMATIC

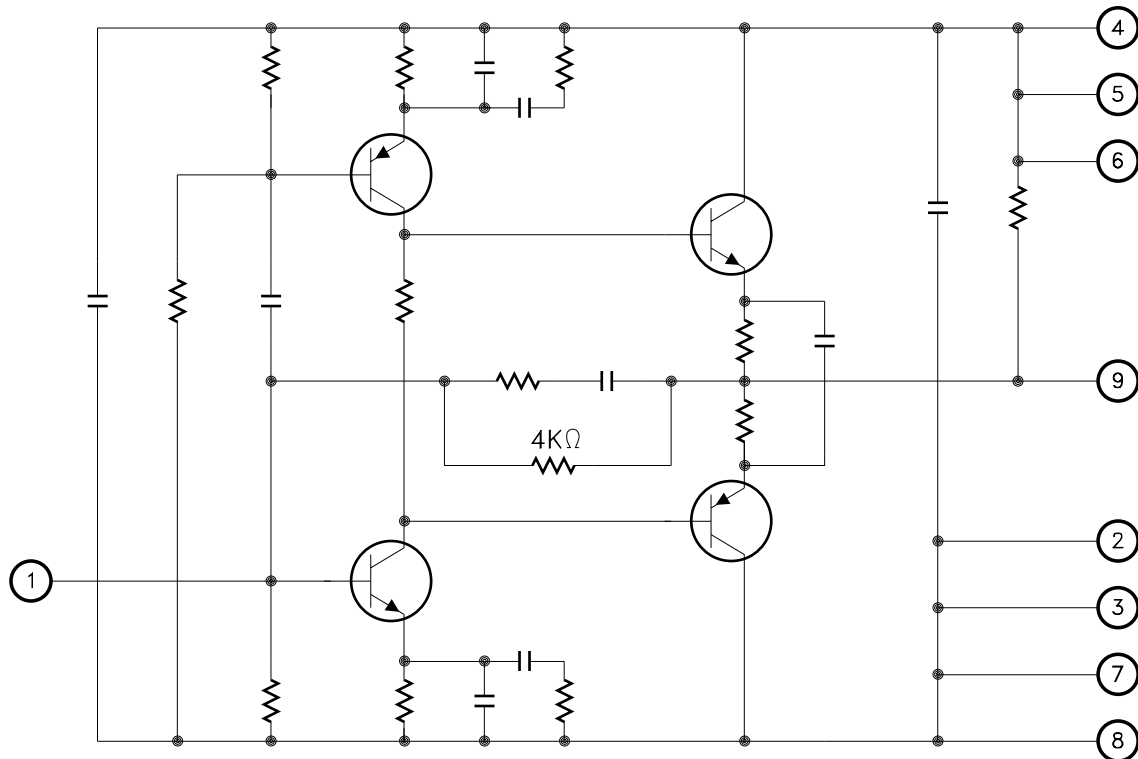

TYPICAL APPLICATIONS

- CRT Driver for Color and Monochrome Monitors
- High Voltage Transimpedance Amplifier
- Ultra High Speed Amplifier for Test Equipment

PIN-OUT INFORMATION

- |                   |          |
|-------------------|----------|
| 1 Inverting Input | 6 Vcc    |
| 2 Ground          | 7 Ground |
| 3 Ground          | 8 Ground |
| 4 Vcc             | 9 Output |
| 5 Vcc             |          |

## ABSOLUTE MAXIMUM RATINGS <sup>⑦</sup>

+ V <sub>CC</sub>	Supply Voltage . . . . .	+ 85V	T <sub>ST</sub>	Storage Temperature Range	-65° C to + 150° C
θ <sub>JC</sub>	Thermal Resistance . . . . . (Junction to Case)	27° C/W	T <sub>LD</sub>	Lead Temperature Range . . . . . (10 Seconds)	300° C
I <sub>IN</sub>	Input Current . . . . .	± 15mA	T <sub>C</sub>	Case Operating Temperature	
I <sub>OUT</sub>	Peak Output Current . . . . .	250mA		MSK641 . . . . .	-40° C to + 85° C
				MSK641G . . . . .	-55° C to + 85° C
			T <sub>J</sub>	Junction Temperature . . . . .	175° C

## ELECTRICAL SPECIFICATIONS

+ V<sub>CC</sub> = + 80V Unless Otherwise Specified

Parameter	Test Conditions <sup>①</sup>	Group A Subgroup	MSK 641G			MSK 641			Units
			Min.	Typ.	Max.	Min.	Typ.	Max.	
STATIC									
Power Supply Current	V <sub>IN</sub> = N/C	1	-	40	45	-	40	50	mA
		2	-	55	65	-	55	-	mA
		3	-	35	45	-	35	-	mA
Input Bias Voltage	V <sub>IN</sub> = N/C	1	1.4	1.55	1.7	1.3	1.55	1.8	V
		2,3	1.35	-	1.8	-	-	-	V
Output Offset Voltage	V <sub>IN</sub> = N/C	1	38	40	42	37	40	43	V
		2,3	36	40	44	-	-	-	V
Input Capacitance <sup>②</sup>	V <sub>IN</sub> = 0.7V	-	-	10	-	-	10	-	pF
Power Supply Range	Derated Performance	-	60	80	85	60	80	85	V
DYNAMIC CHARACTERISTICS									
Output Voltage High	f = 10KHz	4	74	76	-	74	76	-	V
Output Voltage Low	f = 10KHz	4	-	4	6	-	4	6	V
Voltage Gain	V <sub>IN</sub> = 2V <sub>PP</sub> ; f = 10KHz	4	10.5	12.5	14.5	10	12.5	15	V/V
Rise Time	V <sub>OUT</sub> = 40V <sub>PP</sub>	4	-	2.5	3.4	-	2.5	3.5	nS
Fall Time	V <sub>OUT</sub> = 40V <sub>PP</sub>	4	-	2.5	3.4	-	2.5	3.5	nS
Overshoot (Adjustable) <sup>②</sup>	V <sub>OUT</sub> = 20V <sub>PP</sub>	-	-	25	-	-	25	-	%
-3dB Bandwidth <sup>②</sup>	V <sub>OUT</sub> = 20V <sub>PP</sub>	-	125	175	-	120	175	-	MHz
Low Frequency Tilt Voltage <sup>②</sup>	f = 1KHz	-	-	-	1.5	-	-	1.5	V
Linearity Error	f = 10KHz; 5V <sub>PP</sub> ≤ V <sub>OUT</sub> ≤ 50V <sub>PP</sub>	4	-	0.5	5	-	0.5	5	%

## NOTES:

- ① R<sub>IN</sub> = 300Ω, C<sub>IN</sub> = 100pF, C<sub>LOAD</sub> = 8.5pF, R<sub>L</sub> = ∞, unless otherwise specified (See Figure 1).
- ② Guaranteed by design but not tested. Typical parameters are representative of actual device performance but are for reference only.
- ③ Industrial grade devices shall be tested to subgroups 1 and 4 unless otherwise specified.
- ④ Military grade devices ('G' suffix) shall be 100% tested to subgroups 1,2,3 and 4.
- ⑤ Subgroup 5 and 6 testing available upon request.
- ⑥ Subgroup 1,4 T<sub>A</sub> = T<sub>C</sub> = + 25° C  
Subgroup 2,5 T<sub>A</sub> = T<sub>C</sub> = + 85° C  
Subgroup 3,6 T<sub>A</sub> = T<sub>C</sub> = -55° C
- ⑦ Continuous operation at or above absolute maximum ratings may adversely effect the performance and/or life cycle.

## TYPICAL TEST CIRCUIT

The signal source in Figure 1 can be either a fast pulse generator or a network analyzer as long as the output impedance is 50 ohms. The DC level of the input should be 1.55V and all cables should be kept as short as possible. Since total load capacitance should be kept below 8.5pF, a FET probe should be used on the output.

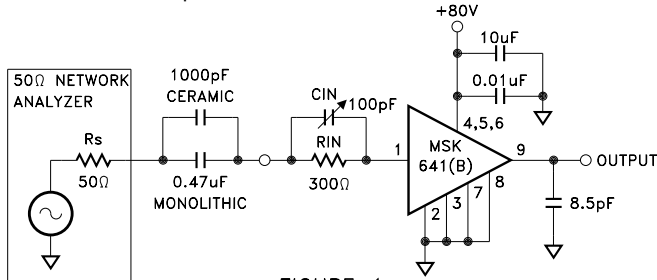

FIGURE 1

## USING THE MSK 641

The output of the amplifier is biased at one half of the power supply voltage. An output voltage swing of  $\pm 35$  volts is typical with a power supply voltage of +80 volts. With an 8.5pF capacitive load, transition times are in the 2.5nS range. If a spark gap current limiting resistor is used on the output of the amplifier and the transition times are degraded, a peaking coil may be used to preserve system performance. The optimum value for this coil will be in the range of 100 to 200nH and can best be determined by trial and error. The output of the MSK 641 is not short circuit protected, therefore, purely resistive loads should be no less than 800 ohms at any time to avoid damaging the output.

## OPERATION CONSIDERATIONS

The input of the MSK 641 rests at a +1.55VDC level with  $V_{cc} = +80$ VDC and the input terminal open. In this state, the output rests at one half of the power supply voltage. When connecting a pulse generator to the input of the amplifier, the DC level should be offset so that the signal is centered around +1.55V. During characterization, the input should be coupled to the MSK 641 through a parallel combination of a variable resistor and variable capacitor peaking circuit. Optimum values for the peaking circuit can be determined experimentally. The optimum value of load capacitance is 8.5pF. Viewing the output with a normal oscilloscope probe would seriously degrade performance. A FET probe fitted with a 100:1 voltage divider will add only approximately 1.5pF of capacitance to the load and is highly recommended. An experimental circuit along with recommended values can be found in Figure 2.

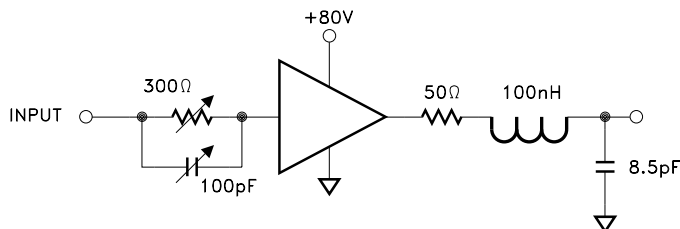

FIGURE 2

## OUTPUT ISSUES

The output of the MSK 641 is a pair of bipolar emitter followers configured in a complimentary push pull configuration. This configuration eliminates the need for a pull up load resistor and makes the amplifier less susceptible to load capacitance variations. Connecting a wire or cable from the output of the amplifier to the CRT cathode can create a resonant circuit which can cause unwanted oscillations or overshoot at its resonant frequency. A damping resistor in series with the lead inductance will alleviate this condition. The optimum value of this resistor can be determined using the following formula:

$$R = 2 * \sqrt{L/C}$$

This resistor also doubles as an arcing protector. In the breadboarding stage, the value of this resistor should be determined experimentally. Resistance in the range of 50 to 100 ohms is usually sufficient. If a quick, simple peaking network is desired, a 300 ohm cable terminated by a capacitor will act like an inductor in the frequency range involved.

## TRANSIMPEDANCE AMPLIFICATION

Transimpedance amplifiers relate input current to output voltage. The MSK 641 contains an internal 4K $\Omega$  feedback resistor. This resistor converts input current to output voltage in the following manner (See Figure 1):

$\pm 1.43$ V (referenced to 1.55Vdc) across the 300 $\Omega$  input resistor results in an input current of  $\pm 4.77$ mA. This current flows through the 4K $\Omega$  feedback resistor and results approximately in a  $\pm 20$ V swing at the output. The actual voltage gain of the typical MSK641 circuit may be slightly less due to transistor losses. The following formula approximates voltage gain including potential losses:

$$\text{Voltage Gain (V/V)} = 4K\Omega / (R_{in} + L) \quad L \approx 25\Omega$$

## HEAT SINKING

The MSK 641 requires heat sinking in most applications. The following formula may be applied to determine if a heat sink is necessary and what size and type to use.

$$R_{\theta Sa} = ((T_j - T_a) / P_d) - (R_{\theta jc}) - (R_{\theta cs})$$

### WHERE

- $T_j$  = Junction Temperature
- $P_d$  = Total power dissipation
- $R_{\theta jc}$  = Junction to case thermal resistance
- $R_{\theta cs}$  = Case to heat sink thermal resistance
- $R_{\theta Sa}$  = Heat sink to ambient thermal resistance
- $T_c$  = Case temperature
- $T_a$  = Ambient temperature
- $T_s$  = Sink temperature

### EXAMPLE

- $T_j = 150^\circ\text{C}$
- $T_a = 85^\circ\text{C}$
- $P_d = 1.5\text{W}$
- $R_{\theta jc} = 27^\circ\text{C/W}$
- $R_{\theta cs} = 0.15^\circ\text{C/W}$

Solving the above equation for  $R_{\theta Sa}$  (heat sink thermal conductivity) shows that the heat sink for this application must have a thermal resistance of no more than 16 $^\circ\text{C/W}$  to maintain a junction temperature of no more than 150 $^\circ\text{C}$ .

# TYPICAL PERFORMANCE CURVES

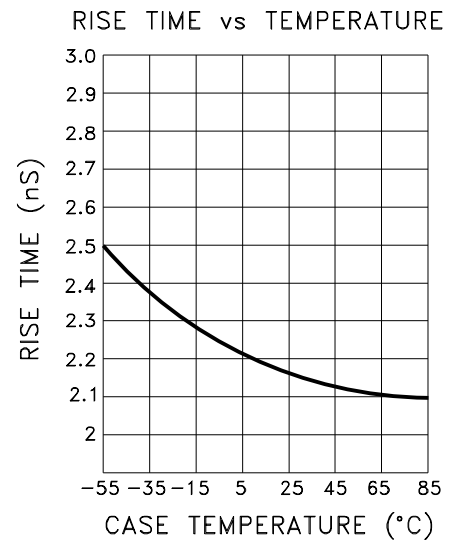
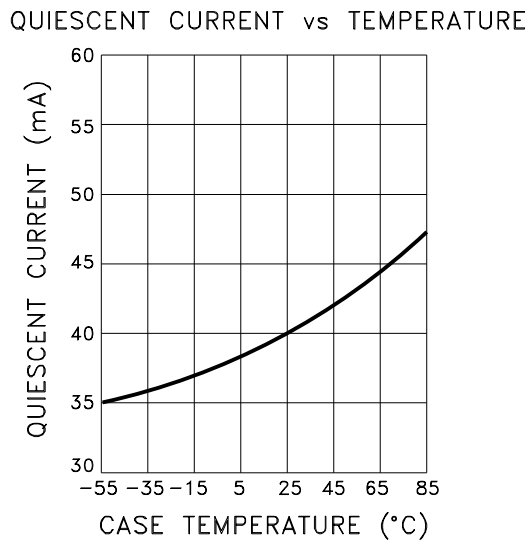
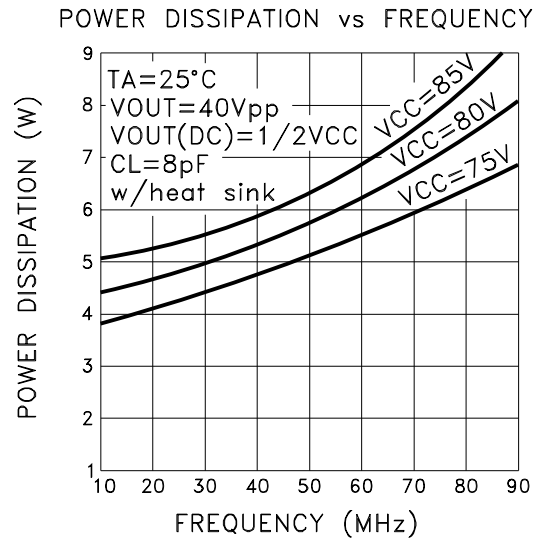
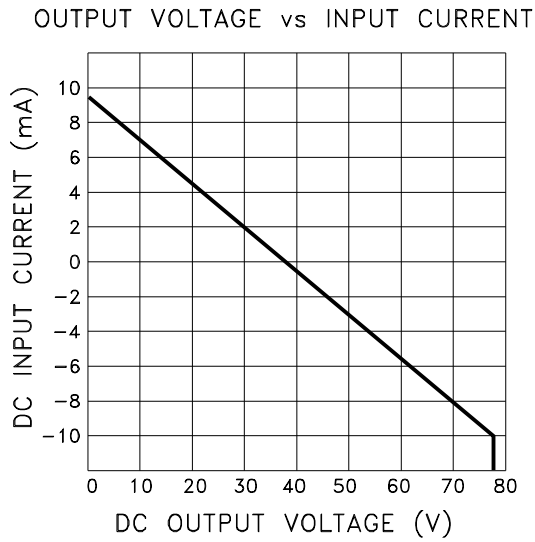
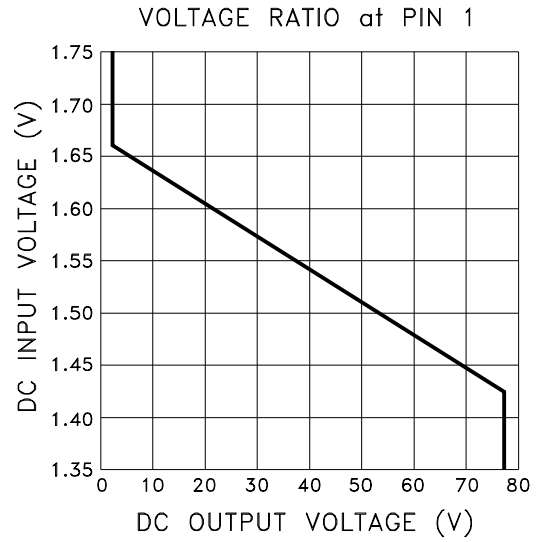
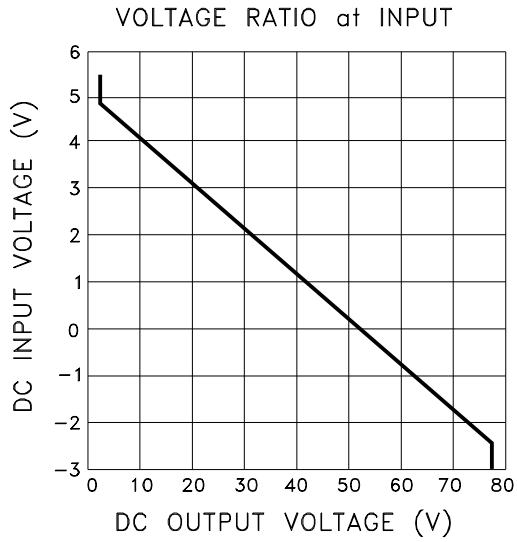

# COMPLETE VIDEO SYSTEM

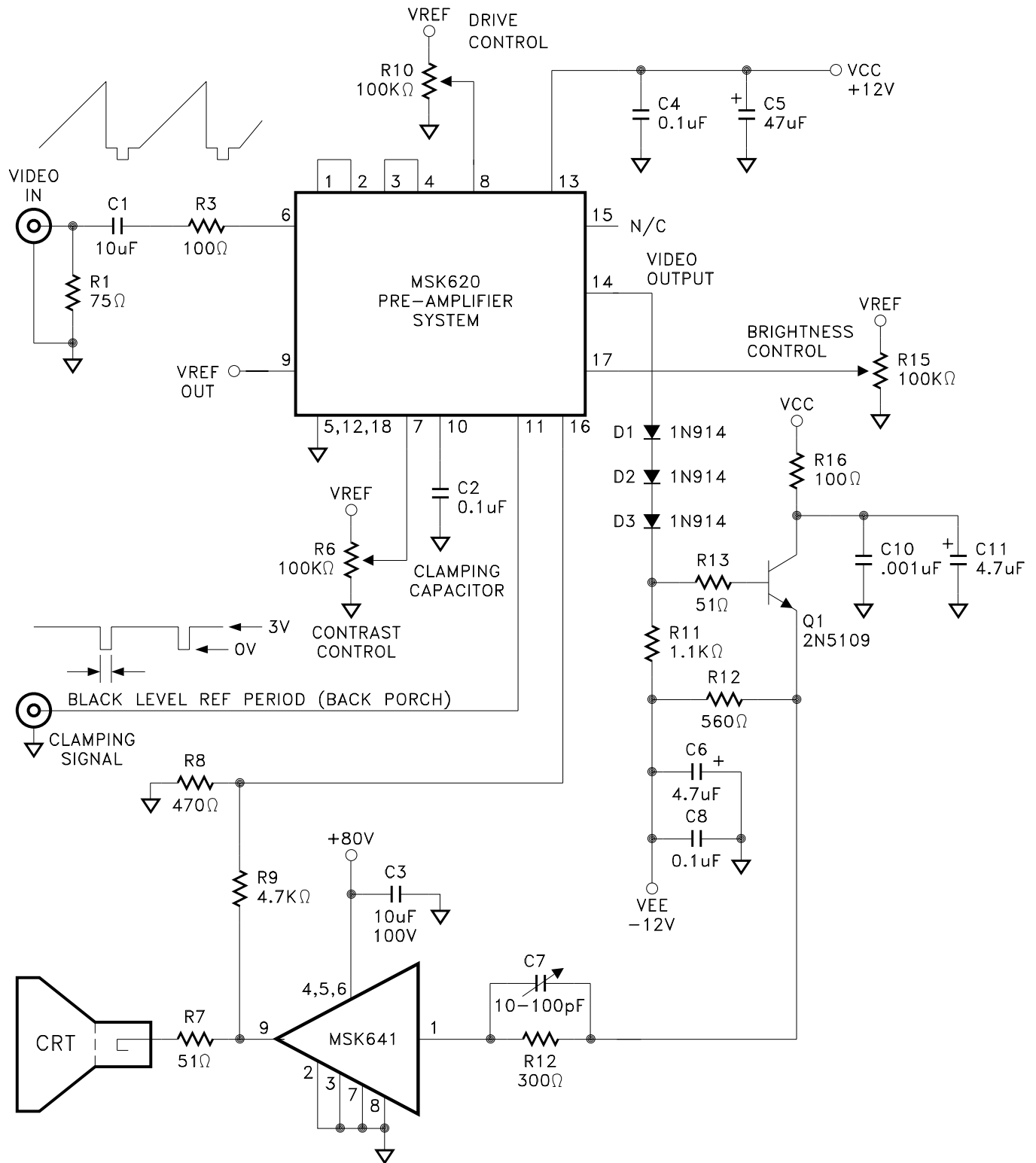
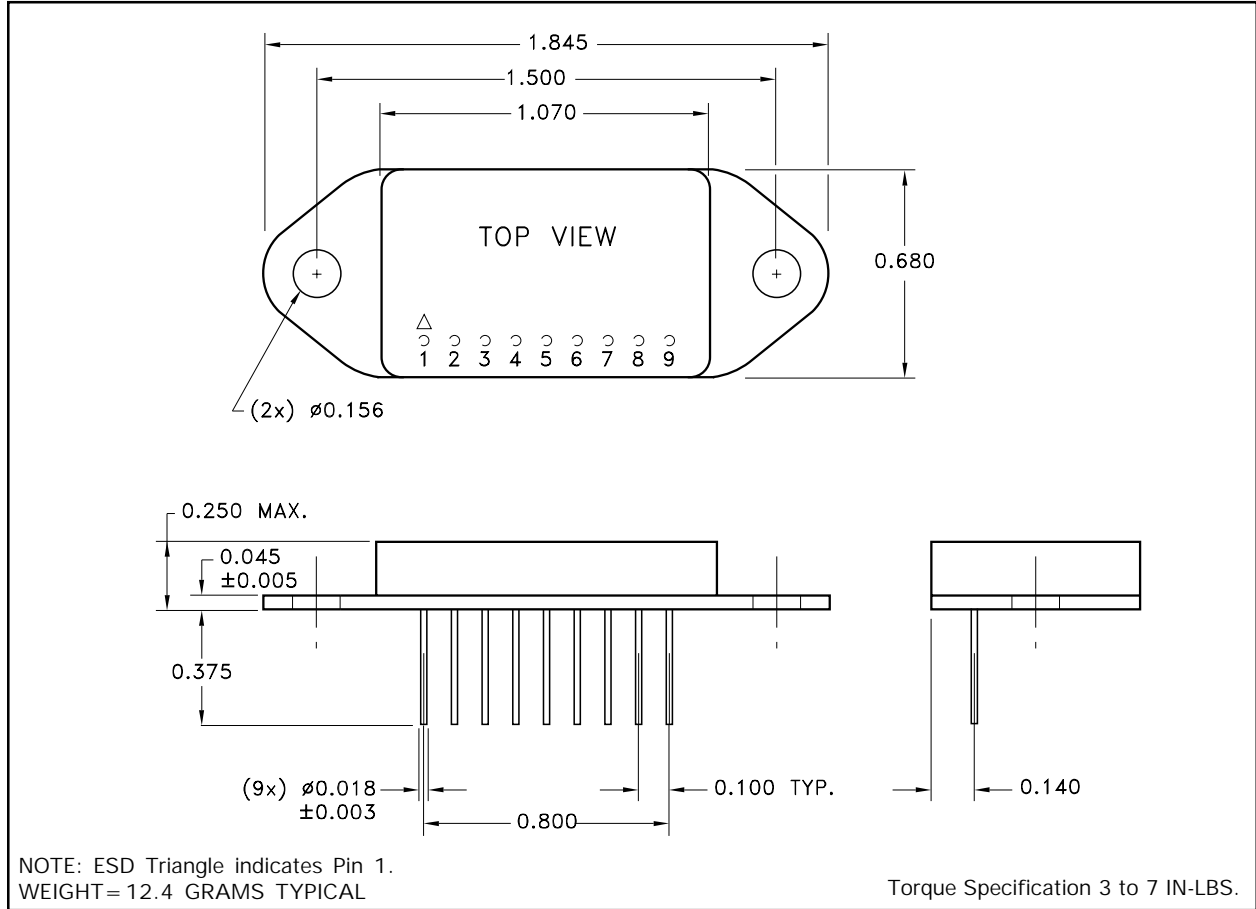

FIGURE 3

Figure 3 above shows how an MSK 620 and MSK 641 can be used to drive a 100MHz monochrome monitor. The video signal is A.C. coupled through C1. The video output pin of the MSK 620 rests at approximately +3.9Vdc and the input of the MSK 641 should be D.C. biased at approximately +1.55Vdc. D1, D2, D3 and Q1 act as a level shifting stage to match the output of the MSK620 and the input of the MSK641. R8 and R9 sample the output and feed it back to the clamping section of the MSK 620 for black level control superior to simply sampling from pin 14 of the MSK 620.

# MECHANICAL SPECIFICATIONS



ALL DIMENSIONS ARE  $\pm 0.010$  INCHES UNLESS OTHERWISE LABELED

## ORDERING INFORMATION

Part Number	Screening Level
MSK641	Industrial
MSK641G	Mil-PRF-38534 Class G

M.S. Kennedy Corp.  
 4707 Dey Road, Liverpool, New York 13088  
 Phone (315) 701-6751  
 FAX (315) 701-6752  
[www.mskennedy.com](http://www.mskennedy.com)

The information contained herein is believed to be accurate at the time of printing. MSK reserves the right to make changes to its products or specifications without notice, however, and assumes no liability for the use of its products. Please visit our website for the most recent revision of this datasheet.

Contact MSK for MIL-PRF-38534 qualification status