

---

**EM78F734N**

**8-Bit  
Microcontroller**

**Product  
Specification**

**DOC. VERSION 1.2**

**ELAN MICROELECTRONICS CORP.**

March 2016

---



---

**Trademark Acknowledgments:**

IBM is a registered trademark and PS/2 is a trademark of IBM.

Windows is a trademark of Microsoft Corporation.

ELAN and ELAN logo  are trademarks of ELAN Microelectronics Corporation.

Copyright © 2016 by **ELAN Microelectronics Corporation**

**All Rights Reserved**

Printed in Taiwan

The contents of this specification are subject to change without further notice. ELAN Microelectronics assumes no responsibility concerning the accuracy, adequacy, or completeness of this specification. ELAN Microelectronics makes no commitment to update, or to keep current the information and material contained in this specification. Such information and material may change to conform to each confirmed order.

In no event shall ELAN Microelectronics be made responsible for any claims attributed to errors, omissions, or other inaccuracies in the information or material contained in this specification. ELAN Microelectronics shall not be liable for direct, indirect, special incidental, or consequential damages arising from the use of such information or material.

The software (if any) described in this specification is furnished under a license or nondisclosure agreement, and may be used or copied only in accordance with the terms of such agreement.

ELAN Microelectronics products are not intended for use in life support appliances, devices, or systems. Use of ELAN Microelectronics product in such applications is not supported and is prohibited.

NO PART OF THIS SPECIFICATION MAY BE REPRODUCED OR TRANSMITTED IN ANY FORM OR BY ANY MEANS WITHOUT THE EXPRESSED WRITTEN PERMISSION OF ELAN MICROELECTRONICS.



---

**ELAN MICROELECTRONICS CORPORATION**

---

**Headquarters:**

No. 12, Innovation Road 1  
Hsinchu Science Park  
Hsinchu, TAIWAN 308  
Tel: +886 3 563-9977  
Fax: +886 3 563-9966  
[webmaster@emc.com.tw](mailto:webmaster@emc.com.tw)  
<http://www.emc.com.tw>

**Hong Kong:**

**Elan (HK) Microelectronics Corporation, Ltd.**  
Flat A, 19F., World Tech Centre  
95 How Ming Street, Kwun Tong  
Kowloon, HONG KONG  
Tel: +852 2723-3376  
Fax: +852 2723-7780

**USA:**

**Elan Information Technology Group (U.S.A.)**  
PO Box 601  
Cupertino, CA 95015  
U.S.A.  
Tel: +1 408 366-8225  
Fax: +1 408 366-8225

**Shenzhen:**

**Elan Microelectronics Shenzhen, Ltd.**  
8A Floor, Microprofit Building  
Gaoxin South Road 6  
Shenzhen Hi-tech Industrial Park  
South Area, Shenzhen  
CHINA 518057  
Tel: +86 755 2601-0565  
Fax: +86 755 2601-0500  
[elan-sz@elanic.com.cn](mailto:elan-sz@elanic.com.cn)

**Shanghai:**

**Elan Microelectronics Shanghai, Ltd.**  
6F, Ke Yuan Building  
No. 5 Bibo Road  
Zhangjiang Hi-Tech Park  
Shanghai, CHINA 201203  
Tel: +86 21 5080-3866  
Fax: +86 21 5080-0273  
[elan-sh@elanic.com.cn](mailto:elan-sh@elanic.com.cn)

---

# Contents

<b>1</b>	<b>General Description .....</b>	<b>1</b>
<b>2</b>	<b>Features .....</b>	<b>1</b>
<b>3</b>	<b>Pin Assignment .....</b>	<b>2</b>
<b>4</b>	<b>Pin Description .....</b>	<b>3</b>
<b>5</b>	<b>Block Diagram .....</b>	<b>5</b>
<b>6</b>	<b>Functional Description.....</b>	<b>6</b>
6.1	Operational Registers .....	6
6.2	Special Function Registers .....	25
6.3	TCC/WDT and Prescaler .....	30
6.4	I/O Ports .....	31
6.5	Reset and Wake-up .....	34
6.6	Interrupt.....	43
6.7	Data EEPROM .....	45
6.7.1	Data EEPROM Control Register .....	45
6.7.1.1	RB (EEPROM Control Register) .....	45
6.7.1.2	RC (128 Bytes EEPROM Address).....	46
6.7.1.3	RD (256 Bytes EEPROM Data) .....	46
6.7.2	Programming Step / Example Demonstration.....	46
6.7.2.1	Programming Step .....	46
6.7.2.2	Example Demonstration Programs.....	47
6.8	Analog-to-Digital Converter (ADC).....	47
6.8.1	ADC Control Register (AISR/R5, ADCON/R6, ADOC/R7).....	48
6.8.2	Bank 2 R5 AISR (ADC Input Select Register).....	48
6.8.3	Bank 2 R6 ADCON (A/D Control Register) .....	49
6.8.4	Bank 2 R7 ADOC (A/D Offset Calibration Register).....	50
6.8.5	ADC Data Buffer (ADDH, ADDL/R8, R9) .....	50
6.8.6	A/D Sampling Time.....	50
6.8.7	A/D Conversion Time .....	51
6.8.8	A/D Operation during Sleep Mode .....	51
6.8.9	Programming Steps/Considerations .....	52
6.8.9.1	Programming Steps .....	52
6.8.9.2	Sample Demonstration Programs.....	52
6.9	Timer/Counter 1.....	54
6.10	Timer/Counter 3.....	55
6.12	Oscillator .....	57
6.12.1	Oscillator Modes.....	57
6.12.2	Internal RC Oscillator Mode .....	60



6.13	Code Option Register .....	60
6.13.1	Code Option Register (Word 0).....	60
6.13.2	Code Option Register (Word 1).....	62
6.13.3	Customer ID Register (Word 2).....	63
6.14	Power-on Considerations .....	64
6.15	External Power-on Reset Circuit.....	64
6.16	Residue-Voltage Protection .....	65
6.17	Instruction Set .....	66
<b>7</b>	<b>Timing Diagrams .....</b>	<b>69</b>
<b>8</b>	<b>Absolute Maximum Ratings.....</b>	<b>70</b>
<b>9</b>	<b>DC Electrical Characteristics.....</b>	<b>71</b>
9.1	Data EEPROM Electrical Characteristics.....	72
9.2	Program Flash Memory Electrical Characteristics.....	73
9.3	A/D Converter Characteristics .....	74
<b>10</b>	<b>AC Electrical Characteristics.....</b>	<b>75</b>
<b>A</b>	<b>Package Type.....</b>	<b>76</b>
<b>B</b>	<b>Package Information .....</b>	<b>78</b>
B.1	EM78F734ND16 300mil .....	78
B.2	EM78F734NSO16 300mil.....	79
B.3	EM78F734NSS16 150mil .....	80
B.4	EM78F734ND18 300mil .....	82
B.5	EM78F734NSO18 300mil.....	83
B.6	EM78F734ND20 300mil .....	84
B.7	EM78F734NSO20 300mil.....	85
B.8	EM78F734NSS20 209mil .....	86
<b>C</b>	<b>Quality Assurance and Reliability .....</b>	<b>87</b>
C.1	Address Trap Detect.....	87

## Specification Revision History

Doc. Version	Revision Description	Date
1.0	Initial version	2014/05/13
1.1	1. Added Channel ADC6 to ADC 2. Added package SSOP20 3. Modified TC1CR, TC2DA and TC2DB description. 4. Modified SSOP16 package type. 5. Added SOP16 150mil package type.	2015/08/10
1.2	1. Add User Application Notice 2. Added Word 0 Bit 12 HLP description. 3. Added Appendix A "Ordering and Manufacturing Information"	2016/03/31

## User Application Note

*(Before using this chip, take a look at the following description note, it includes important messages.)*

1. The internal TCC will stop running when in sleep mode. However, during AD conversion, when TCC is set to "SLEP" instruction, if the ADWE bit of the RE register is enabled, the TCC will keep on running.
2. During ADC conversion, do not perform output instruction to maintain precision for all of the pins. In order to obtain accurate values, it is necessary to avoid any data transition on I/O pins during AD conversion
3. The noise rejection function is turned off in the Fs and sleep mode



## 1 General Description

The EM78F734N is an 8-bit microprocessor designed and developed with low-power, high-speed CMOS technology and high noise immunity. It has an on-chip 4K×13-bit Electrical Flash Memory and 128×8-bit In-system programmable EEPROM. It provides three protection bits to prevent intrusion of user's Flash memory code.

With its enhanced Flash-ROM feature, the EM78F734N provides a convenient way of developing and verifying user's programs. Moreover, this Flash-ROM device offers the advantages of easy and effective program updates, using development and programming tools. Users can avail of the ELAN Writer to easily program their development codes.

## 2 Features

- **CPU Configuration**
  - 4K×13 bits Flash memory
  - 144×8 bits on-chip registers (SRAM)
  - 128 bytes In-system programmable EEPROM
  - 8-level stacks for subroutine nesting
- **I/O Port Configuration**
  - Three bidirectional I/O ports
  - Wake-up port : P6
  - 12 Programmable pull-down I/O pins
  - 8 programmable pull-high I/O pins
  - 4 programmable open-drain I/O pins
  - External interrupt : P60
- **Operating Voltage Range:**
  - 2.2V~5.5V @ - 40°C ~85°C (Industrial)
  - 2.2V~5.5V @ 0°C ~70°C (Commercial)
- **Operating frequency range (base on two clocks):**
  - IRC Drift Rate (Vdd @ 3.3V)
- **Eight available interrupts:**
  - Internal interrupt: 4
  - External interrupt: 4
- **Eight channels Analog-to-Digital Converter with 12-bit resolution**
- **Peripheral Configuration**
  - 8-bit real Timer Clock/Counter (TCC) with selective signal sources, trigger edges, and overflow interrupt
  - Power down (Sleep) mode
  - Four programmable Level Voltage Reset (LVR) (LVR) : 3.3V, 3.0V, 2.6V, and 2.0V (POR)
  - Three security registers to prevent intrusion of Flash memory codes
  - One configuration register to accommodate user's requirements
  - Two clocks per instruction cycle
  - High EFT immunity
  - Two sub-frequencies; 128kHz and 16kHz, the 16kHz is provided by dividing the 128kHz
- **Single instruction cycle commands**
- **Five Crystal Range in Oscillator Mode**

Internal RC Frequency	Drift Rate		
	Temperature (-10°C+40°C)	Process	Total
455kHz	±1%	±1%	±2%
1 MHz	±1%	±1%	±2%
4 MHz	±1%	±1%	±2%
8 MHz	±1%	±1%	±2%

- IRC Drift Rate (Temperature: -10°C+40°C)

Internal RC Frequency	Drift Rate		
	Voltage (3.0~3.6V)	Process	Total
455kHz	±1%	±1%	±2%
1 MHz	±1%	±1%	±2%
4 MHz	±1%	±1%	±2%
8 MHz	±1%	±1%	±2%

- **One 16-bit Timer/Counter**
  - TC1 : Timer/Counter/Capture
- **One 8-bit Timer/Counter**
  - TC3 : Timer/Counter/PDO (Programmable Divider Output) / PWM (Pulse Width Modulation)
- **Programmable free running Watchdog Timer**
- **Package Type:**
  - 16-pin DIP 300mil : EM78F734ND16
  - 16-pin SOP 300mil : EM78F734NSO16
  - 16-pin SOP 150mil : EM78F734NSO16A
  - 16-pin SSOP 150mil : EM78F734NSS16
  - 18-pin DIP 300mil : EM78F734ND18
  - 18-pin SOP 300mil : EM78F734NSO18
  - 20-pin DIP 300 mil : EM78F734ND20
  - 20-pin SOP 300mil : EM78F734NSO20
  - 20-pin SSOP 209mil : EM78F734NSS20

**Note:** These are Green Products which do not contain hazardous substances.

### 3 Pin Assignment

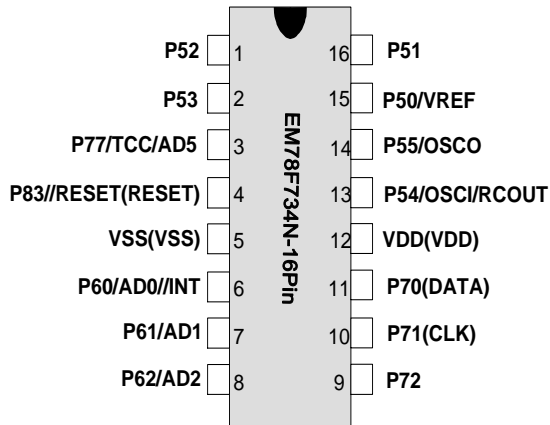

Figure 3-1 EM78F734ND16/SO16/SO16A/SS16

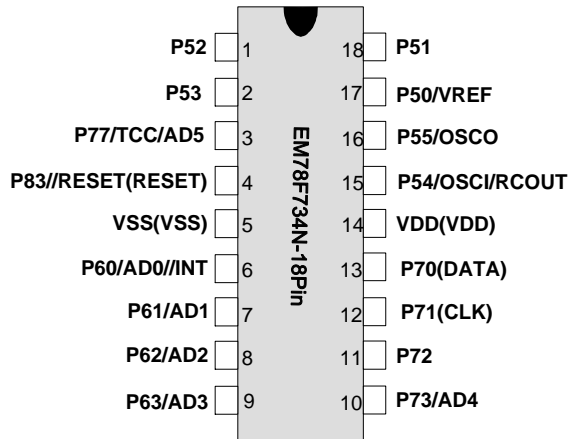

Figure 3-2 EM78F734ND18/SO18

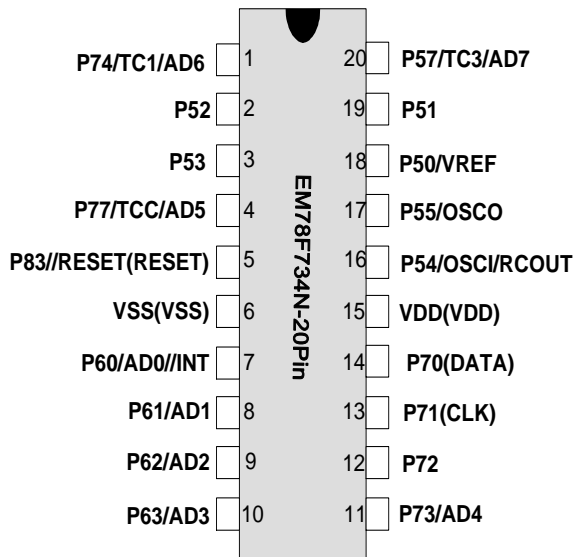

Figure 3-3 EM78F734ND20/SO20/SS20

## 4 Pin Description

**Table 1 EM78F734N Pin Description**

**Legend:**      **ST:** Schmitt Trigger input      **AN:** analog pin  
**CMOS:**        CMOS output                              **XTAL:** Oscillation pin for crystal / resonator

Name	Function	Input Type	Output Type	Description
P50/VREF	P50	ST	CMOS	Bidirectional I/O pin with programmable pull-down
	VREF	AN	–	ADC external voltage reference
P51	P51	ST	CMOS	Bidirectional I/O pin with programmable pull-down
P52	P52	ST	CMOS	Bidirectional I/O pin with programmable pull-down
P53	P53	ST	CMOS	Bidirectional I/O pin with programmable pull-down
P54/OSCI/RCOUT	P54	ST	CMOS	Bidirectional I/O pin
	OSCI	XTAL	–	External clock crystal resonator oscillator input pin
	RCOUT	–	CMOS	Clock output of internal RC oscillator Clock output of external RC oscillator (open-drain)
P55/OSCO	P55	ST	CMOS	Bidirectional I/O pin
	OSCO	–	XTAL	Clock output from crystal oscillator
P57/TC3/AD7	P57	ST	CMOS	Bidirectional I/O pin
	TC3	ST	–	Timer 3 input (Counter/Capture/Window) Timer 3 output (PDO/PWM/Buzzer)
	PDO	–	CMOS	Programmable divider output
	AD7	AN	–	ADC Input 7
P60/AD0//INT	P60	ST	CMOS	Bidirectional I/O pin with programmable pull-down, pull-high, open-drain, and pin change wake-up
	AD0	AN	–	ADC Input 0
	/INT	ST	–	External interrupt pin
P61/AD1	P61	ST	CMOS	Bidirectional I/O pin with programmable pull-down, pull-high, open-drain, and pin change wake-up
	AD1	AN	–	ADC Input 1

(Continuation)

Name	Function	Input Type	Output Type	Description
P62/AD2	P62	ST	CMOS	Bidirectional I/O pin with programmable pull-down, pull-high, open-drain, and pin change wake-up
	AD2	AN	–	ADC Input 2
P63/AD3	P63	ST	CMOS	Bidirectional I/O pin with programmable pull-down, pull-high, open-drain, and pin change wake-up
	AD3	AN	–	ADC Input 3
P70 (DATA)	P70	ST	CMOS	Bidirectional I/O pin, pull-high
	(DATA)	ST	CMOS	DATA pin for Writer programming
P71 (CLK)	P71	ST	CMOS	Bidirectional I/O pin, pull-high
	(CLK)	ST	–	CLOCK pin for Writer programming
P72	P72	ST	CMOS	Bidirectional I/O pin, pull-high
P73/AD4	P73	ST	CMOS	Bidirectional I/O pin, pull-high
	AD4	AN	–	ADC Input 4
P74/TC1/AD6	P74	ST	CMOS	Bidirectional I/O pin
	TC1	ST	–	Timer 1 input (Counter/Capture)
	AD6	AN	–	ADC Input 6
P77/TCC/AD5	P77	ST	CMOS	Bidirectional I/O pin
	TCC	ST	–	Real Time Clock/Counter clock input
	AD5	AN	–	ADC Input 5
P83//RESET (/RESET)	P83	ST	CMOS	Bidirectional I/O pin
	/RESET	ST	–	Internal pull-high reset pin
	(/RESET)	ST	–	/RESET pin for Writer programming
VDD (VDD)	VDD	Power	–	Power
	VDD	Power	–	VDD for Writer programming
VSS (VSS)	VSS	Power	–	Ground
	VSS	Power	–	VSS for Writer programming



## 6 Functional Description

### 6.1 Operational Registers

#### 6.1.1 R0 (Indirect Addressing Register)

R0 is not a physically implemented register. It is used as an indirect addressing pointer. Any instruction using R0 as a pointer actually accesses data pointed by the RAM Select Register (R4).

#### 6.1.2 R1 (Timer Clock/Counter)

R1 is incremented by an external signal edge, which is defined by TE bit (CONT-4) through the TCC pin, or by the instruction cycle clock. It is writable and readable as any other registers. It is defined by resetting PSTE (CONT-3).

The prescaler is assigned to TCC, if the PSTE bit (CONT-3) is reset. The contents of the prescaler counter are cleared only when the TCC register is written with a value.

#### 6.1.3 R2 (Program Counter) and Stack

Depending on the device type, R2 and hardware stack are 10-bit wide. The structure is depicted in Figure 6-1.

The configuration structure generates  $4K \times 13$  bits on-chip Flash ROM addresses to the relative programming instruction codes. One program page is 1024 words long.

R2 is set as all "0"s when under a reset condition.

"JMP" instruction allows direct loading of the lower 10 program counter bits. Thus, "JMP" allows PC to go to any location within a page (1K).

"CALL" instruction loads the lower 10 bits of the PC, and then PC+1 is pushed into the stack. Thus, the subroutine entry address can be located anywhere within a page.

"LJMP" instruction allows direct loading of the program counter bits (A0~A11). Thus, "LJMP" allows the PC to go to any location within 4K ( $2^{12}$ ).

"LCALL" instruction loads the program counter bits (A0~A11), and PC+1 are pushed onto the stack. Thus, the subroutine entry address can be located anywhere within 4K ( $2^{12}$ ).

"RET" ("RETL k", "RETI") instruction loads the program counter with the contents of the top-level stack.

"ADD R2, A" allows a relative address to be added to the current PC, and the ninth and above bits of the PC will increase progressively.

“MOV R2, A” allows loading an address from the “A” register to the lower 8 bits of the PC, and the ninth and tenth bits of the PC remain unchanged.

Any instruction except “ADD R2,A” that is written to R2 (e.g. “MOV R2, A”, “BC R2, 6”) will cause the ninth bit and the tenth bit (A8~A9) of the PC to remain unchanged.

All instructions are single instruction cycle (fclk/2) except for the instructions that would change the contents of R2 and “LCALL”, “LJMP”, “TBRD” instruction. The “LCALL”, “LJMP” and “TBRD” instructions need two instruction cycles.

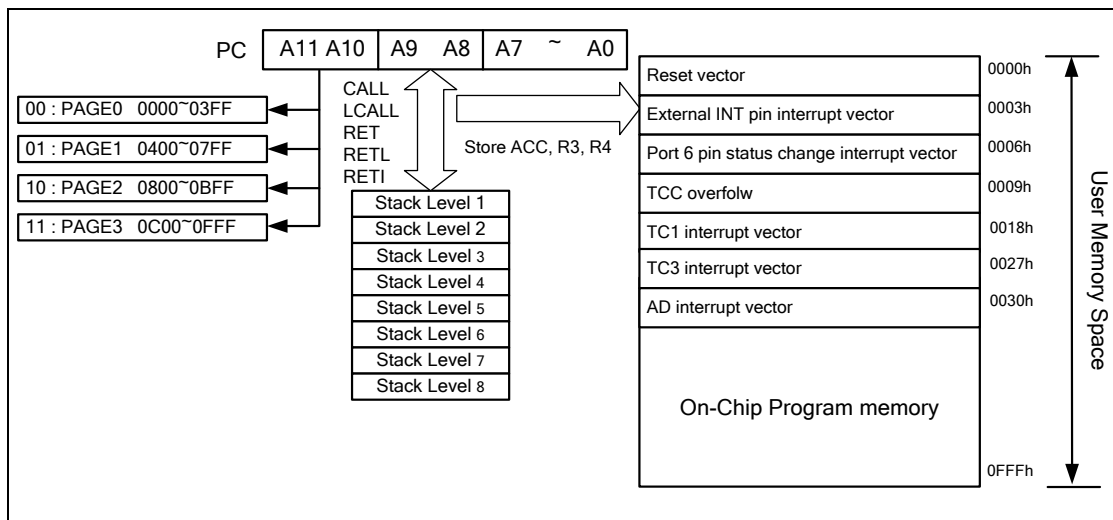

Figure 6-1 Program Counter Organization

Address	Register Bank 0	Register Bank 1	Register Bank 2	Register Bank 3	Control Register
01	R1 (TCC Buffer)				
02	R2 (PC)				
03	R3 (STATUS)				
04	R4 (RSR, bank select)	R4(7,6) (0,1)	(1,0)	(1,1)	
05	R5 (Port 5 I/O data)	R5 (Timer 1 Control)	R5 (ADC Input Select Register)	R5 (Reserve)	IOC5 (Port 5 I/O control)
06	R6 (Port 6 I/O data)	R6 (Timer 1 data Buffer A)	R6 (ADC Control Register)	R6 (TBHP: Table Point Register)	IOC6 (Port 6 I/O control)
07	R7 (Port 7 I/O data)	R7 (Timer 1 data Buffer B)	R7 (ADC Offset Calibration Register)	R7 (Reserve)	IOC7 (Port 7 I/O control)
08	R8 (Port 8 I/O data)	R8 (Oscillator Control)	R8 (AD high 8-bits data buffer)	R8 (Reserve)	IOC8 (Port 8 I/O control)
09	R9 (TBLP: Table Point Register)	R9 (Timer 2 Data Buffer A)	R9 (AD low 4-bits data buffer)	R9 (Reserve)	IOC9 (Reserved)
0A	RA (Wake control Register)	RA (Timer 2 Data Buffer B)	RA (Reserve)	RA (Reserve)	IOCA (WDT control)
0B	RB (EEPROM control Register)	RB (Reserve)	RB (Reserve)	RB (Reserve)	IOCB (Pull Down Control 2)
0C	RC (EEPROM address Register)	RC (Reserve)	RC (Reserve)	RC (Reserve)	IOCC (Open Drain Control 1)
0D	RD (EEPROM data Register)	RD (Reserve)	RD (Reserve)	RD (Timer 3 Control)	IOCD (Pull High Control 2)
0E	RE (Mode Select Register)	RE (Reserve)	RE (Reserve)	RE (Timer 3 data buffer)	IOCE (Interrupt Mask 2)
0F	RF (Interrupt Status Flag 1)	RF (Interrupt Status Flag 2)	RF (Pull High Control 1)	RF (Pull Down Control 1)	IOCF (Interrupt Mask 1)
10 : 1F	16-Byte Common Register				
20 : 3F	Bank 0 32x8	Bank 1 32x8	Bank 2 32x8	Bank 3 32x8	

Figure 6-2 Data Memory Configuration

### 6.1.4 R3 (Status Register)

Bit 7	Bit 6	Bit 5	Bit 4	Bit 3	Bit 2	Bit 1	Bit 0
–	–	–	T	P	Z	DC	C

**Bits 7 ~ 5:** Not used, set to “0” at all time

**Bit 4 (T):** Time-out bit

Set to “1” with the “SLEP” and “WDTC” commands, or during power up and reset to “0” by WDT time-out.

**Bit 3 (P):** Power down bit

Set to “1” during power on or by a “WDTC” command and reset to “0” by a “SLEP” command.

**Bit 2 (Z):** Zero flag

Set to “1” if the result of an arithmetic or logic operation is zero.

**Bit 1 (DC):** Auxiliary carry flag

**Bit 0 (C):** Carry flag

### 6.1.5 R4 (RAM Select Register)

**Bits 7 ~ 6:** Used to select Bank 0 ~ Bank 3

**Bits 5 ~ 0:** Used to select registers (Address: 00~3F) in indirect addressing mode.

See the data memory configuration in Figure 6-2.

### 6.1.6 Bank 0 R5 ~ R8 (Port 5 ~ Port 8)

R5 ~ R7 are I/O registers.

### 6.1.7 Bank 0 R9 TBPTL (Low byte of Table Pointer Register)

Bit 7	Bit 6	Bit 5	Bit 4	Bit 3	Bit 2	Bit 1	Bit 0
RBit 7	RBit 6	RBit 5	RBit 4	RBit 3	RBit 2	RBit 1	RBit 0

### 6.1.8 Bank 0 RA (Wake- up Control Register)

Bit 7	Bit 6	Bit 5	Bit 4	Bit 3	Bit 2	Bit 1	Bit 0
-	ICWE	ADWE	EXWE	-	-	-	-

**Bit 7:** Not used, set to “0” at all time

**Bit 6 (ICWE):** Port 6 input status change wake-up enable bit

0 : Disable Port 6 input status change wake-up

1 : Enable Port 6 input status change wake-up

**Bit 5 (ADWE):** ADC wake-up enable bit

0 : Disable ADC wake-up

1 : Enable ADC wake-up

When ADC completed status is used to enter the interrupt vector or to wake up the EM78F734N from sleep, with A/D conversion running, the ADWE bit must be set to “Enable”.

**Bit 4 (EXWE):** External wake-up enable bit

0 : Disable External /INT pin wake-up

1 : Enable External /INT pin wake-up

**Bits 3 ~ 0:** Not used, set to “0” at all time

### 6.1.9 Bank 0 RB (EEPROM Control Register)

Bit 7	Bit 6	Bit 5	Bit 4	Bit 3	Bit 2	Bit 1	Bit 0
RD	WR	EEWE	EEDF	EEPC	-	-	-

**Bit 7 (RD):** Read control register

- 0 : Does not execute EEPROM read
- 1 : Read EEPROM content, (RD can be set by software, RD is cleared by hardware after Read instruction is completed)

**Bit 6 (WR):** Write control register

- 0 : Write cycle to the EEPROM is completed.
- 1 : Initiate a write cycle, (WR can be set by software, WR is cleared by hardware after Write cycle is completed)

**Bit 5 (EEWE):** EEPROM Write Enable bit.

- 0 : Prohibit write to the EEPROM
- 1 : Allows EEPROM write cycles

**Bit 4 (EEDF):** EEPROM Detective Flag

- 0 : Write cycle is completed
- 1 : Write cycle is unfinished

**Bit 3 (EEPC):** EEPROM power-down control bit

- 0 : Switch off the EEPROM
- 1 : EEPROM is operating

**Bits 2 ~ 0:** Not used, set to "0" at all time

### 6.1.10 Bank 0 RC (EEPROM Address)

Bit 7	Bit 6	Bit 5	Bit 4	Bit 3	Bit 2	Bit 1	Bit 0
-	EE_A6	EE_A5	EE_A4	EE_A3	EE_A2	EE_A1	EE_A0

**Bits 6 ~ 0:** EEPROM address

### 6.1.11 Bank 0 RD (EEPROM Data)

Bit 7	Bit 6	Bit 5	Bit 4	Bit 3	Bit 2	Bit 1	Bit 0
EE_D7	EE_D6	EE_D5	EE_D4	EE_D3	EE_D2	EE_D1	EE_D0

**Bits 7 ~ 0:** EEPROM data

### 6.1.12 Bank 0 RE (CPU Operating Control Register)

Bit 7	Bit 6	Bit 5	Bit 4	Bit 3	Bit 2	Bit 1	Bit 0
-	TIMERSC	CPUS	IDLE-	-			

**Bit 7:** Not used, set to “0” at all time

**Bit 6 (TIMERSC):** TCC, TC1, TC3 clock source select

**0 :** Fs. Fs: sub frequency for WDT internal RC time base

**1 :** Fm. Fm: main-oscillator clock

**Bit 5 (CPUS):** CPU Oscillator Source Select

**0 =** Sub-oscillator (fs)

**1 =** Main oscillator (fosc)

When CPUS=0, the CPU oscillator selects a sub-oscillator and the **main oscillator is stopped**.

**Bit 4 (IDLE):** Idle Mode Enable Bit. This bit determines the Idle mode status under SLEP instruction.

**0 :** IDLE=“0”+SLEP instruction → Sleep mode

**1 :** IDLE=“1”+SLEP instruction → Idle mode

#### ■ CPU Operation Mode

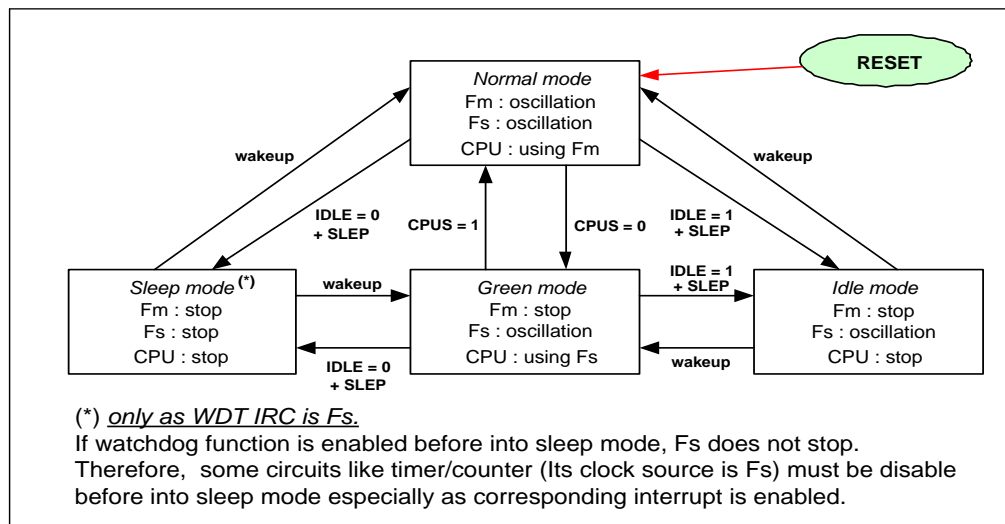

Figure 6-3 CPU Operation Mode

**Bits 3 ~ 0:** Not used, set to “0” at all time

### 6.1.13 Bank 0 RF (Interrupt Status Register)

Bit 7	Bit 6	Bit 5	Bit 4	Bit 3	Bit 2	Bit 1	Bit 0
-	ADIF	-	-	-	EXIF	ICIF	TCIF

**Note:** "1" means with interrupt request "0" means no interrupt occurs

- Bit 7:** Not used, set to "0" at all time
- Bit 6 (ADIF):** Interrupt flag for analog to digital conversion. Set when AD conversion is completed, reset by software.
- Bits 5 ~ 3:** Not used, set to "0" at all time
- Bit 2 (EXIF):** External interrupt flag. Set by a falling edge on /INT pin, reset by software.
- Bit 1 (IC IF):** Port 6 input status change interrupt flag. Set when Port 6 input changes, reset by software.
- Bit 0 (TCIF):** TCC overflow interrupt flag. Set when TCC overflows, reset by software.

Bank 0 RF can be cleared by instruction but cannot be set.

IOCF is the interrupt mask register.

**NOTE**

*The result of reading Bank 0 RF is the "logic "ND" of Bank 0 RF and IOCF.*

### 6.1.14 R10 ~ R3F

These are all 8-bit general-purpose registers.

### 6.1.15 Bank 1 R5 TC1CR (Timer 1 Control)

Bit 7	Bit 6	Bit 5	Bit 4	Bit 3	Bit 2	Bit 1	Bit 0
TC1CAP	TC1S	TC1M	TC1ES	TC1MOD	TCK1CK2	TC1CK1	TC1CK0

- Bit 7 (TC1CAP):** Software capture control  
**0 :** Software capture disable  
**1 :** Software capture enable
- Bit 6 (TC1S):** Timer/Counter 1 start control  
**0 :** Stop and clear the counter  
**1 :** Start Timer/Counter 1

**Bit 5 (TC1M):** Timer/Counter 1 mode select

- 0** : Timer/Counter 1 mode
- 1** : Capture mode

**Bit 4 (TC1ES):** TC1 signal edge

- 0** : increment if the transition from low to high (rising edge) takes place on the TC1 pin.
- 1** : increment if the transition from high to low (falling edge) takes place on TC1 pin.

**Bit 3 (TC1MOD):** Timer Operation Mode Selection Bit

- 0**: Two 8-bit timers
- 1**: Timer 1 and 2 are cascaded as one 16-bit timer. The corresponding control register of 16-bit timer is from timer 1. TC1DA and TC2DA are low byte. TC1DB and TC2DB are high byte.

**Bit 2 ~ Bit 0 (TC1CK2 ~ TC1CK0):** Timer/Counter 1 clock source select

TC1CK2	TC1CK1	TC1CK0	Clock Source	Resolution 8 MHz	Max. time 8 MHz	Resolution 16kHz	Max. time 16kHz
			Normal	$F_c/8M$	$F_c=8M$	$F_c=16K$	$F_c=16K$
0	0	0	$F_c/2^{23}$	1.05s	19.1hr	145hr	9544hr
0	0	1	$F_c/2^{13}$	1.024ms	67.11s	512ms	33554.432s
0	1	0	$F_c/2^8$	32 $\mu$ s	2.097s	16ms	1048.576s
0	1	1	$F_c/2^3$	1 $\mu$ s	65.536ms	0.5ms	32768ms
1	0	0	$F_c/2^2$	0.5 $\mu$ s	32.768ms	0.25ms	16384ms
1	0	1	$F_c/2$	0.25 $\mu$ s	16.384ms	125 $\mu$ s	8192ms
1	1	0	$F_c$	125ns	8.192ms	0.0625ms	4096ms
1	1	1	External clock (TC1 pin)	-	-	-	-

**Bits 1 ~ 0:** Not used, set to "0" at all time.

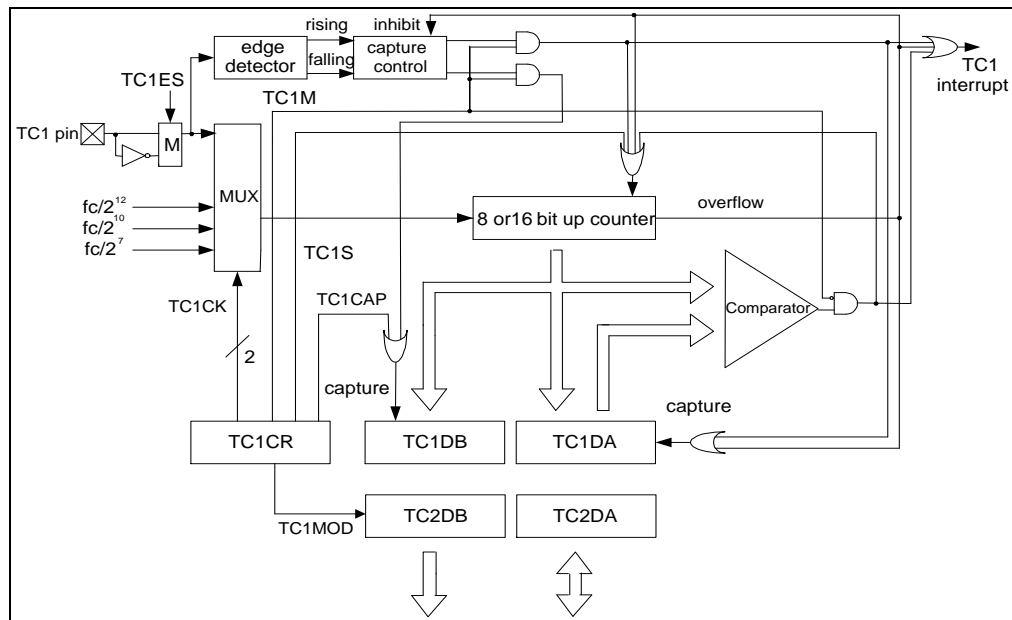

Figure 6-4 Timer/Counter 1 Configuration

**In Timer mode**, counting up is performed using the internal clock. When the contents of the up-counter matched with the TC1DA, interrupt is generated and the counter is cleared. Counting up resumes after the counter is cleared. The current contents of the up-counter are loaded into TC1DB by setting TC1CAP to “1” and the TC1CAP is automatically cleared to “0” after capture. The timer mode will operate with 16bits by setting TC1MOD to “1”

**In Counter mode**, counting up is performed using the external clock input pin (TC1 pin) and either rising or falling edge can be selected by TC1ES, **but both edges cannot be used**. When the contents of the up-counter matched with the TC1DA, interrupt is generated and the counter is cleared. Counting up resumes after the counter is cleared. The current contents of the up-counter are loaded into the TC1DB by setting TC1CAP to “1” and the TC1CAP is automatically cleared to “0” after capture. The counter mode will operate with 16 bits by setting TC1MOD to “1”.

**In Capture mode**, the pulse width, period and duty of the TC1 input pin are measured in this mode, which can be used to decode the remote control signal. The counter is set as free running by the internal clock. On a rising (falling) edge of TC1 pin input, the contents of the counter is loaded into TC1DA, then the counter is cleared and interrupt is generated. On a falling (rising) edge of the TC1 pin input, the contents of the counter are loaded into TC1DB. The counter is still counting, on the next rising edge of the TC1 pin input, the contents of the counter are loaded into TC1DA, the counter is cleared and interrupt is generated again. If an overflow occurs before an edge is detected, the FFH is loaded into TC1DA and the overflow interrupt is generated. During interrupt processing, it can be determined whether there is an overflow by checking if the TC1DA value is FFH. After an interrupt (capture to TC1DA or overflow detection) is generated, capture and overflow detection are halted until TC1DA is read out. The capture mode will operate with 16 bits by setting TC1MOD to “1”.

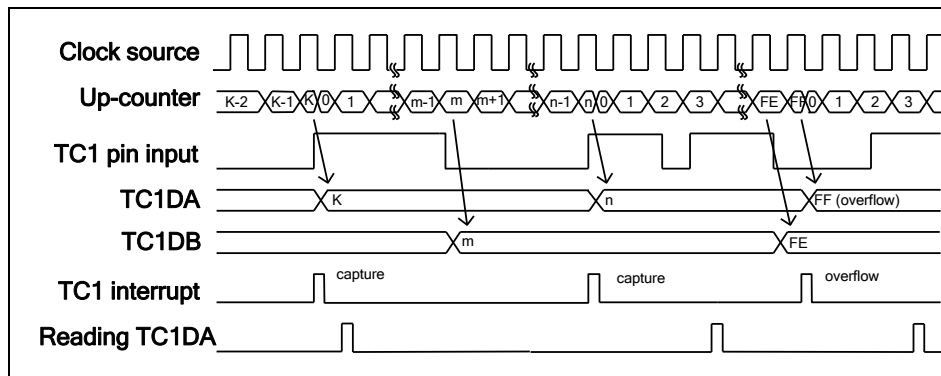

Figure 6-5 (a) Timing Chart of 8 bits Capture Mode

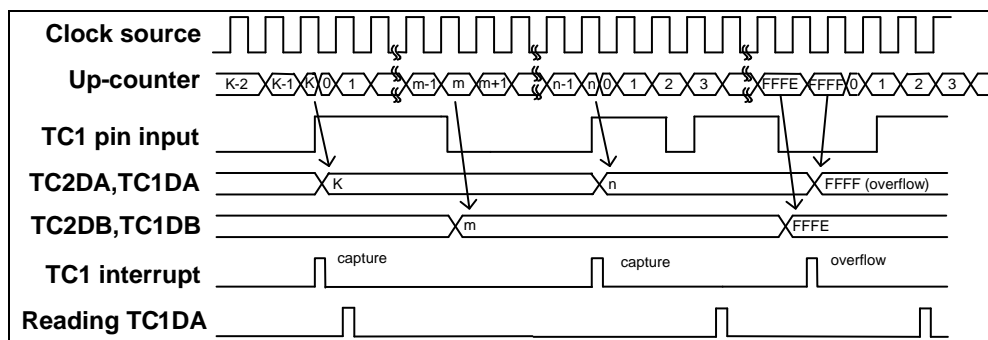

Figure 6-5 (b) Timing Chart of 16 bits Capture Mode

### 6.1.16 Bank 1 R6 TC1DA (Timer 1 Data Buffer A)

Bit 7	Bit 6	Bit 5	Bit 4	Bit 3	Bit 2	Bit 1	Bit 0
TC1DA7	TC1DA6	TC1DA5	TC1DA4	TC1DA3	TC1DA2	TC1DA1	TC1DA0

Bit 7 ~ Bit 0 (TC1DA7 ~ TC1DA0): Data buffer of 8-bit Timer/Counter 1.

### 6.1.17 Bank 1 R7 TC1DB (Timer 1 Data Buffer B)

Bit 7	Bit 6	Bit 5	Bit 4	Bit 3	Bit 2	Bit 1	Bit 0
TC1DB7	TC1DB6	TC1DB5	TC1DB4	TC1DB3	TC1DB2	TC1DB1	TC1DB0

Bit 7 ~ Bit 0 (TC1DB7 ~ TC1DB0): Data buffer of 8-bit Timer/Counter 1.

### 6.1.18 Bank 1 R8 OSCR (Oscillator Control)

Bit 7	Bit 6	Bit 5	Bit 4	Bit 3	Bit 2	Bit 1	Bit 0
RCM1	RCM0	–	–	–	–	–	–

Bit 7 and Bit 6 (RCM1, RCM0): IRC mode select bits

Writer Trim IRC	Bank1 R8<7,6>		Frequency
	RCM1	RCM0	
4 MHz	0	0	4 MHz
	0	1	1 MHz
	1	0	8 MHz
	1	1	455kHz
1 MHz	0	0	4 MHz
	0	1	1 MHz
	1	0	8 MHz
	1	1	455kHz
8 MHz	0	0	4 MHz
	0	1	1 MHz
	1	0	8 MHz
	1	1	455kHz
455kHz	0	0	4 MHz
	0	1	1 MHz
	1	0	8 MHz
	1	1	455kHz

#### NOTE

- Bank 1 R8<7, 6 > of the initialized values are kept the same as Word 1<3,2>.
- After A Frequency switches to B Frequency, EM78F734N needs to hold some stable time on B frequency  
*Ex: Writer trim IRC 4 MHz → Bank 1 R8<7,6> set to "10" → holds 3 μs → EM78F734N works on 8 MHz ± 10%*

Code Option Word 1 COBS=0:

The R8<7, 6 > of the initialized values will remain the same as Word 1<3, 2>.

The R8<7, 6 > cannot change frequency.

Code Option Word 1 COBS=1:

The R8<7, 6 > of the initialized values will remain the same Word as 1<3, 2>.

The R8<7, 6> can change when user wants to work on other IRC frequency.

### 6.1.19 Bank 1 R9 TC2DA (Timer 2 Data Buffer A)

Bit 7	Bit 6	Bit 5	Bit 4	Bit 3	Bit 2	Bit 1	Bit 0
TC2DA7	TC2DA6	TC2DA5	TC2DA4	TC2DA3	TC2DA2	TC2DA1	TC2DA0

Bits 7~0 (TC2DA7~ TC2DA0): Data buffer of 8-bit Timer/Counter 2 cascade with Timer/Counter 1 at TC1MOD set to "1"

### 6.1.20 Bank 1 RA TC2DB (Timer 2 Data Buffer B)

Bit 7	Bit 6	Bit 5	Bit 4	Bit 3	Bit 2	Bit 1	Bit 0
TC2DB7	TC2DB6	TC2DB5	TC2DB4	TC2DB3	TC2DB2	TC2DB1	TC2DB0

Bit 7 ~ Bit 0 (TC2DB7 ~ TC2DB0): Data buffer of 8-bit Timer/Counter 2 cascade with Timer/Counter 1 at TC1MOD set to "1" ..

### 6.1.21 Bank 1 RB ~RE

These are reserved registers.

### 6.1.22 Bank 1 RF (Interrupt Status Register)

Bit 7	Bit 6	Bit 5	Bit 4	Bit 3	Bit 2	Bit 1	Bit 0
-	-	TCIF3	-	TCIF1	-	-	-

**Note:** "1" means with interrupt request "0" means no interrupt occurs

**Bits 7~6:** Not used, set to "0" at all time

**Bit 5 (TCIF3):** 8-bit Timer/Counter 3 interrupt flag. The Interrupt flag is cleared by software.

**Bit 4:** Not used, set to "0" at all time

**Bit 3 (TCIF1):** 8-bit Timer/Counter 1 interrupt flag. The Interrupt flag is cleared by software.

**Bits 2~0:** Not used, set to "0" at all time

Bank 1 RF can be cleared by instruction but cannot be set.

IOCE is the interrupt mask register.

**NOTE**

The result of reading Bank 1 RF is the "Logic "ND" of Bank 1 RF and IOCE.

### 6.1.23 Bank 2 R5 AISR (ADC Input Select Register)

The AISR register for ADC pins act as analog input or digital I/O.

Bit 7	Bit 6	Bit 5	Bit 4	Bit 3	Bit 2	Bit 1	Bit 0
ADE7	ADE6	ADE5	ADE4	ADE3	ADE2	ADE1	ADE0

**Bit 7 (ADE7):** AD converter enable bit of P57 pin.

0 : Disable ADC7, P57 functions as I/O pin.

1 : Enable ADC7 to function as analog input pin

**Bit 6 (ADE6):** AD converter enable bit of P74 pin.

0 : Disable ADC6, P74 functions as I/O pin.

1 : Enable ADC6 to function as analog input pin

**Bit 5 (ADE5):** AD converter enable bit of P77 pin

0 : Disable ADC5, P77 functions as I/O pin

1 : Enable ADC5 to function as analog input pin

**Bit 4 (ADE4):** AD converter enable bit of P73 pin

0 : Disable ADC4, P73 functions as I/O pin

1 : Enable ADC4 to function as analog input pin

**Bit 3 (ADE3):** AD converter enable bit of P63 pin.

0 : Disable ADC3, P63 functions as I/O pin

1 : Enable ADC3 to function as analog input pin

**Bit 2 (ADE2):** AD converter enable bit of P62 pin.

0 : Disable ADC2, P62 functions as I/O pin

1 : Enable ADC2 to function as analog input pin

**Bit 1 (ADE1):** AD converter enable bit of P61 pin

0 : Disable ADC1, P61 functions as I/O pin

1 : Enable ADC1 to function as analog input pin

**Bit 0 (ADE0):** AD converter enable bit of P60 pin

0 : Disable ADC0, P60 functions as I/O pin

1 : Enable ADC0 to function as analog input pin

The following table shows the priority of P60/AD1//INT.

P60/AD0//INT Pin Priority		
High	Medium	Low
/INT	AD0	P60

### 6.1.24 Bank 2 R6 ADCON (A/D Control Register)

Bit 7	Bit 6	Bit 5	Bit 4	Bit 3	Bit 2	Bit 1	Bit 0
VREFS	CKR1	CKR0	ADRUN	ADPD	ADIS2	ADIS1	ADIS0

**Bit 7 (VREFS):** The input source of the Vref of the ADC.

**0 :** Vref of the ADC is connected to the Internal reference which is selected by Bank 2 R9<5,4>(default value), and the P50/VREF pin carries out the function of P50

**1 :** Vref of the ADC is connected to P50/VREF

**Bit 6 ~ Bit 5 (CKR1 ~ CKR0):** The oscillator clock rate of ADC

CKR1/CKR0	Operation Mode	Max. Operation Frequency
00	$F_{osc}/4$	4 MHz
01	$F_{osc}$	1 MHz
10	$F_{osc}/16$	8 MHz
11	$F_{osc}/2$	1 MHz

RCM[1:0]*	Frequency (MHz)	Sample and Hold Timing
00	4	$8 \times T_{AD}$
01	1	$4 \times T_{AD}$
10	8	$12 \times T_{AD}$
11	455k	$2 \times T_{AD}$

\*When using XT, LXT1, HXT1, HXT2 mode can also modify RCM[1:0] at Code Option Word 1 to set the Sample and Hold time.

**Bit 4 (ADRUN):** ADC starts to run

**0 :** Reset upon completion of AD conversion. This bit cannot be reset by software.

**1 :** A/D conversion is started. This bit can be set by software.

**Bit 3 (ADPD):** ADC Power-down mode

**0 :** Switch off the resistor reference to save power even while the CPU is operating.

**1 :** ADC is operating

**Bits 2~0 (ADIS2~ADIS0): AD Input Select Bits**

ADIS2	ADIS1	ADIS0	AD Input Pin
0	0	0	AD0
0	0	1	AD1
0	1	0	AD2
0	1	1	AD3
1	0	0	AD4
1	0	1	AD5
1	1	0	AD6
1	1	1	AD7

### 6.1.25 Bank 2 R7 ADOC (A/D Offset Calibration Register)

Bit 7	Bit 6	Bit 5	Bit 4	Bit 3	Bit 2	Bit 1	Bit 0
-	-	-	-	-	PDE	Reserved	Reserved

**Bits 7~3:** Not used, set to "0" at all time

**Bit 2 (PDE):** 1/2 VDD Power Detect Enable bit

0 : Disable Power Detect (Default)

1 : Enable Power Detect

PDE	ADIS2	ADIS1	ADIS0	AD Input Select
1	-	-	-	1/2VDD
0	x	x	x	ADx

**Bits 1~0:** Reserved, must be set to "0" at all time

### 6.1.26 Bank 2 R8 ADDH (AD High 8-Bit Data Buffer)

Bit 7	Bit 6	Bit 5	Bit 4	Bit 3	Bit 2	Bit 1	Bit 0
ADD11	ADD10	ADD9	ADD8	ADD7	ADD6	ADD5	ADD4

When the A/D conversion is completed, the result which is high 8-bit is loaded into the ADDH. The ADRUN bit is cleared, and the ADIF is set. R8 is read only.

### 6.1.27 Bank 2 R9 ADDL (AD Low 4-Bit Data Buffer)

Bit 7	Bit 6	Bit 5	Bit 4	Bit 3	Bit 2	Bit 1	Bit 0
-	-	IRVS1	IRVS0	ADD3	ADD2	ADD1	ADD0

**Bits 7 ~ 6:** Not used, set to "0" at all time

**Bits 5 ~ 4 (IRVS1~IRVS0):** Internal Reference Voltage Selection.

IRVS[1:0]	Reference Voltage
00	AVDD
01	4 V
10	3 V
11	2.5 V

**Bits 3 ~ 0:** AD low 4-bit data buffer.

### 6.1.28 Bank 2 RA ~ RE

These are reserved registers.

### 6.1.29 Bank 2 RF (Pull-high Control Register 1)

Bit 7	Bit 6	Bit 5	Bit 4	Bit 3	Bit 2	Bit 1	Bit 0
-	-	-	-	/PH73	/PH72	/PH71	/PH70

**Bits 7 ~ 4:** Not used, set to “0” at all time.

**Bit 3 (/PH73):** Control bit used to enable pull-high of the P73 pin

0 : Enable internal pull-high

1 : Disable internal pull-high

**Bit 2 (/PH72):** Control bit used to enable pull-high of the P72 pin.

**Bit 1 (/PH71):** Control bit used to enable pull-high of the P71 pin.

**Bit 0 (/PH70):** Control bit used to enable pull-high of the P70 pin.

The RF Register is both readable and writable.

### 6.1.30 Bank 3 R5

Reserved Register

### 6.1.31 Bank 3 R6 TBPTH (High Byte of Table Pointer Register)

Bit 7	Bit 6	Bit 5	Bit 4	Bit 3	Bit 2	Bit 1	Bit 0
MLB	0	0	0	RBit 11	RBit 10	RBit 9	RBit 8

**Bit 7 (MLB):** Take MSB or LSB at machine code.

**Bits 6 ~ 4:** Not used. Set to “0” at all time.

**Bits 3 ~ 0:** Table Pointer Address Bits 11~8.

### 6.1.32 Bank 3 R7~RC

Reserved Registers

### 6.1.33 Bank 3 RD TC3CR (Timer 3 Control)

Bit 7	Bit 6	Bit 5	Bit 4	Bit 3	Bit 2	Bit 1	Bit 0
TC3FF1	TC3FF0	TC3S	TC3CK2	TC3CK1	TC3CK0	TC3M1	TC3M0

**Bit 7 ~ Bit 6 (TC3FF1 ~ TC3FF0):** Timer/Counter 3 flip-flop control

TC3FF1	TC3FF0	Operating Mode
0	0	Clear
0	1	Toggle
1	0	Set
1	1	Reserved

**Bit 5 (TC3S):** Timer/Counter 3 start control

**0 :** Stop and clear the counter

**1 :** Start Timer/Counter 3

**Bit 4 ~ Bit 2 (TC3CK2 ~ TC3CK0):** Timer/Counter 3 Clock Source select

TC3CK2	TC3CK1	TC3CK0	Clock Source	Resolution	Max. Time
			Normal	Fc=8M	Fc=8M
0	0	0	$Fc/2^{11}$	250 $\mu$ s	64 ms
0	0	1	$Fc/2^7$	16 $\mu$ s	4 ms
0	1	0	$Fc/2^5$	4 $\mu$ s	1 ms
0	1	1	$Fc/2^3$	1 $\mu$ s	255 $\mu$ s
1	0	0	$Fc/2^2$	500 ns	127.5 $\mu$ s
1	0	1	$Fc/2^1$	250 ns	63.8 $\mu$ s
1	1	0	Fc	125 ns	31.9 $\mu$ s
1	1	1	External clock (TC3 pin)	-	-

**Bit 1 ~ Bit 0 (TC3M1 ~ TC3M0):** Timer/Counter 3 operating mode select

TC3M1	TC3M0	Operating Mode
0	0	Timer/Counter
0	1	Reserved
1	0	Programmable Divider output
1	1	Pulse Width Modulation output

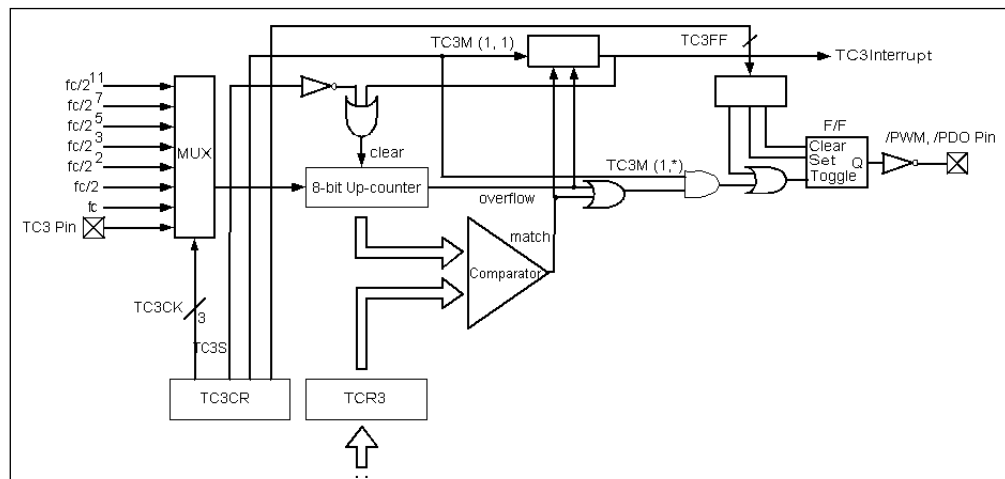

Figure 6-6 Timer / Counter 3 Configuration

**In Timer mode,** counting up is performed using internal clock (rising edge trigger). When the contents of the up-counter match the TCR3, then interrupt is generated and the counter is cleared. Counting up resumes after the counter is cleared.

**In Counter mode**, counting up is performed using external clock input pin (TC3 pin). When the contents of the up-counter match the TCR3, then interrupt is generated and the counter is cleared. Counting up resumes after the counter is cleared.

**In Programmable Divider Output (PDO) mode**, counting up is performed using the internal clock. The contents of TCR3 are compared with the contents of the up-counter. The F/F output is toggled and the counter is cleared each time a match is found. The F/F output is inverted and output to /PDO pin. This mode can generate 50% duty pulse output. The F/F can be initialized by the program and it is initialized to “0” during reset. A TC3 interrupt is generated each time the /PDO output is toggled.

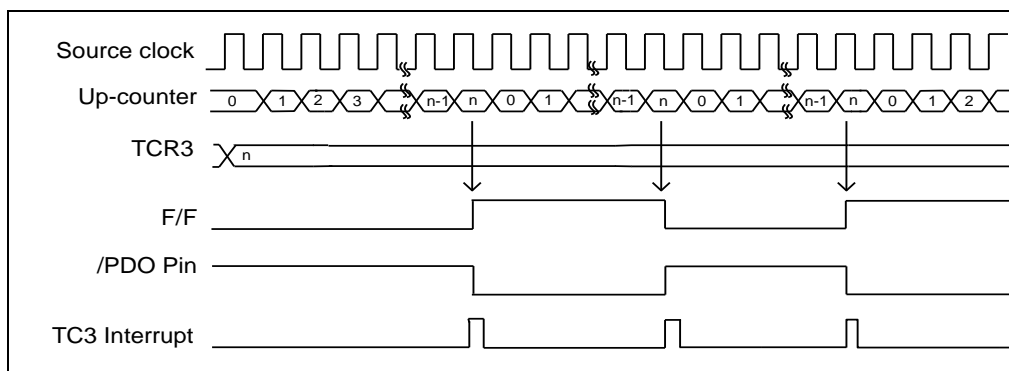

Figure 6-7 PDO Mode Timing Chart

**In Pulse Width Modulation (PWM) Output mode**, counting up is performed using internal clock. The contents of TCR3 are compared with the contents of the up-counter and TCR3 should be greater than 1(including 1) . The F/F is toggled when a match is found. The counter continues counting, the F/F is toggled again when the counter overflows, after which the counter is cleared. The F/F output is inverted and output to /PWM pin. A TC3 interrupt is generated each time an overflow occurs. TCR3 is configured as a 2-stage shift register and, during output, will not switch until one output cycle is completed even if TCR3 is overwritten. Therefore, the output can be changed continuously. Also, the first time, TRC3 is shifted by setting TC3S to “1” after data is loaded to TCR3.

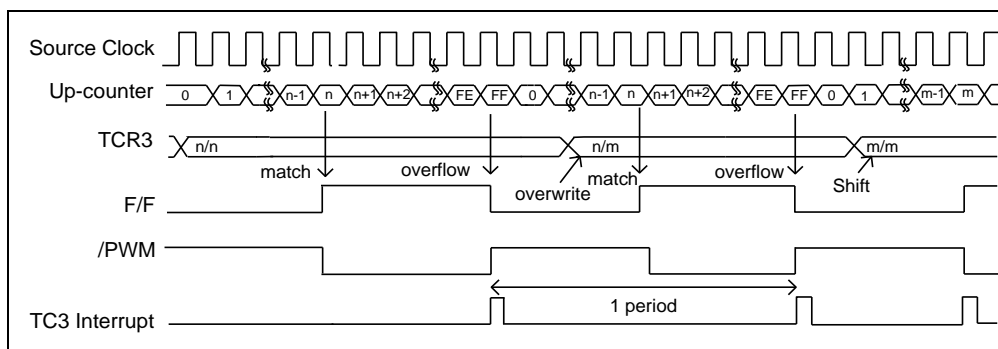

Figure 6-8 PWM Mode Timing Chart

### 6.1.34 Bank 3 RE TC3D (Timer 3 Data Buffer)

Bit 7	Bit 6	Bit 5	Bit 4	Bit 3	Bit 2	Bit 1	Bit 0
TC3D7	TC3D6	TC3D5	TC3D4	TC3D3	TC3D2	TC3D1	TC3D0

**Bit 7 ~ Bit 0 (TC3D7 ~ TC3D0):** Data Buffer of 8-bit Timer/Counter 3

### 6.1.35 Bank 3 RF (Pull-down Control Register 1)

Bit 7	Bit 6	Bit 5	Bit 4	Bit 3	Bit 2	Bit 1	Bit 0
-	-	-	-	/PD73	/PD72	/PD71	/PD70

**Bit 7~ Bit 4:** Not used, set to “0” at all time

**Bit 3 (/PD73):** Control bit used to enable the P73 pull-down pin

0 : Enable internal pull-down

1 : Disable internal pull-down

**Bit 2 (/PD72):** Control bit used to enable the P72 pull-down pin

**Bit 1 (/PD71):** Control bit used to enable the P71 pull-down pin

**Bit 0 (/PD70):** Control bit used to enable the P70 pull-down pin

The RF Register is both readable and writable.

## 6.2 Special Function Registers

### 6.2.1 A (Accumulator)

Internal data transfer operation, or instruction operand holding usually involves the temporary storage function of the Accumulator, which is not an addressable register.

### 6.2.2 CONT (Control Register)

Bit 7	Bit 6	Bit 5	Bit 4	Bit 3	Bit 2	Bit 1	Bit 0
INTE	/INT	TS	TE	PSTE	PST2	PST1	PST0

**Bit 7 (INTE):** INT signal edge

0 : interrupt occurs at the rising edge of the INT pin

1 : interrupt occurs at the falling edge of the INT pin

**Bit 6 (/INT):** Interrupt Enable flag

0 : masked by DISI or hardware interrupt

1 : enabled by ENI/RETI instructions

**Bit 5 (TS):** TCC signal source

0 : internal instruction cycle clock

1 : transition on the TCC pin

**Bit 4 (TE):** TCC signal edge

0 : increment if a transition from low to high takes place on the TCC pin

1 : increment if a transition from high to low takes place on the TCC pin

**Bit 3 (PSTE):** Prescaler enable bit for TCC

0 : prescaler disable bit, TCC rate is 1:1

1 : prescaler enable bit, TCC rate is set at Bit 2~Bit 0

**Bit 2 ~ Bit 0 (PST 2 ~ PST0):** TCC prescaler bits

PST2	PST1	PST0	TCC Rate
0	0	0	1:2
0	0	1	1:4
0	1	0	1:8
0	1	1	1:16
1	0	0	1:32
1	0	1	1:64
1	1	0	1:128
1	1	1	1:256

The CONT register is both readable and writable.

### 6.2.3 IOC5 ~ IOC8 (I/O Port Control Register)

A value "1" sets the relative I/O pin into high impedance, while "0" defines the relative I/O pin as output.

IOC5, IOC6 IOC7 and IOC8 registers are both readable and writable.

### 6.2.4 IOC9

Reserved registers

### 6.2.5 IOCA (WDT Control Register)

Bit 7	Bit 6	Bit 5	Bit 4	Bit 3	Bit 2	Bit 1	Bit 0
WDTE	EIS	-	-	PSWE	PSW2	PSW1	PSW0

**Bit 7 (WDTE):** Control bit used to enable the Watchdog timer

0 : Disable WDT

1 : Enable WDT

WDTE is both readable and writable.

**Bit 6 (EIS):** Control bit used to define the function of P60 (INT) pin

0 : P60, bidirectional I/O pin

1 : INT, external interrupt pin. In this case, the I/O control bit of P60 (Bit 0 of IOC6) must be set to "1".

When EIS is “0”, the path of /INT is masked. When EIS is “1”, the status of the /INT pin can also be read by way of reading Port 6 (R6).

EIS is both readable and writable.

**Bits 5~4:** Not used, set to “0” at all time

**Bit 3 (PSWE):** Prescaler enable bit for WDT

0 : prescaler disable bit, WDT rate is 1:1

1 : prescaler enable bit, WDT rate is set at Bit 0~Bit 2

**Bit 2 ~ Bit 0 (PSW2 ~ PSW0):** WDT prescaler bits

PSW2	PSW1	PSW0	WDT Rate
0	0	0	1:2
0	0	1	1:4
0	1	0	1:8
0	1	1	1:16
1	0	0	1:32
1	0	1	1:64
1	1	0	1:128
1	1	1	1:256

### 6.2.6 IOCB (Pull-down Control Register 2)

Bit 7	Bit 6	Bit 5	Bit 4	Bit 3	Bit 2	Bit 1	Bit 0
/PD7	/PD6	/PD5	/PD4	/PD3	/PD2	/PD1	/PD0

**Bit 7 (/PD7):** Control bit used to enable pull-down of the of P63 pin

0 : Enable internal pull-down

1 : Disable internal pull-down

**Bit 6 (/PD6):** Control bit used to enable pull-down of the P62 pin

**Bit 5 (/PD5):** Control bit used to enable pull-down of the P61 pin

**Bit 4 (/PD4):** Control bit used to enable pull-down of the P60 pin

**Bit 3 (/PD3):** Control bit used to enable pull-down of the P53 pin

**Bit 2 (/PD2):** Control bit used to enable pull-down of the P52 pin

**Bit 1 (/PD1):** Control bit used to enable pull-down of the P51 pin

**Bit 0 (/PD0):** Control bit used to enable pull-down of the P50 pin

The IOCB Register is both readable and writable.

### 6.2.7 IOCC (Open-drain Control Register)

Bit 7	Bit 6	Bit 5	Bit 4	Bit 3	Bit 2	Bit 1	Bit 0
–	–	–	–	OD3	OD2	OD1	OD0

**Bits 7 ~ 4:** Not used, set to “0” at all time

**Bit 3 (OD3):** Control bit used to enable the open-drain output of P63 pin

0 : Disable open-drain output

1 : Enable open-drain output

**Bit 2 (OD2):** Control bit used to enable the open-drain output of P62 pin

**Bit 1 (OD1):** Control bit used to enable the open-drain output of P61 pin

**Bit 0 (OD0):** Control bit used to enable the open-drain output of P60 pin

The IOCC Register is both readable and writable.

### 6.2.8 IOCD (Pull-high Control Register 2)

Bit 7	Bit 6	Bit 5	Bit 4	Bit 3	Bit 2	Bit 1	Bit 0
–	–	–	–	/PH3	/PH2	/PH1	/PH0

**Bits 7~4:** Not used, set to “0” at all time

**Bit 3 (/PH3):** Control bit used to enable pull-high of the P63 pin.

0 : Enable internal pull-high

1 : Disable internal pull-high

**Bit 2 (/PH2):** Control bit used to enable pull-high of the P62 pin.

**Bit 1 (/PH1):** Control bit used to enable pull-high of the P61 pin.

**Bit 0 (/PH0):** Control bit used to enable pull-high of the P60 pin.

The IOCD Register is both readable and writable.

### 6.2.9 IOCE (Interrupt Mask Register 2)

Bit 7	Bit 6	Bit 5	Bit 4	Bit 3	Bit 2	Bit 1	Bit 0
–	–	TCIE3	–	TCIE1	–	–	–

**Bits 7~6:** Not used, set to “0” at all time

**Bit 5 (TCIE3):** Interrupt enable bit

0 : Disable TCIF3 interrupt

1 : Enable TCIF3 interrupt

**Bit 4:** Not used, set to “0” at all time

**Bit 3 (TCIE1):** Interrupt enable bit  
**0:** Disable TCIF1 interrupt  
**1:** Enable TCIF1 interrupt

**Bits 2~0:** Not used, set to “0” at all time

### 6.2.10 IOCF (Interrupt Mask Register 1)

Bit 7	Bit 6	Bit 5	Bit 4	Bit 3	Bit 2	Bit 1	Bit 0
–	ADIE	–	–	–	EXIE	ICIE	TCIE

**Bit 7:** Not used, set to “0” at all time

**Bit 6 (ADIE):** ADIF interrupt enable bit

**0 :** Disable ADIF interrupt

**1 :** Enable ADIF interrupt

When the ADC Complete is used to enter an interrupt vector or enter the next instruction, the ADIE bit must be set to “Enable”.

**Bits 5 ~ 3:** Not used, set to “0” at all time

**Bit 2 (EXIE):** EXIF interrupt enable bit

**0 :** Disable EXIF interrupt

**1 :** Enable EXIF interrupt

Perform the following steps from the EXINT, First set EXIE, and then set the EIS. EXINT internal comparison value default is “0”. Then set the rising edge and the INT pin to high, since doing EXINT setting will cause immediate trigger signal and generate an interrupt.

**Bit 1 (ICIE):** ICIF interrupt enable bit

**0 :** Disable ICIF interrupt

**1 :** Enable ICIF interrupt

**Bit 0 (TCIE):** TCIF interrupt enable bit

**0 :** Disable TCIF interrupt

**1 :** Enable TCIF interrupt

Individual interrupt is enabled by setting its associated control bit in the IOCF to “1”.

Global interrupt is enabled by the ENI instruction and is disabled by the DISI instruction. The IOCF register is both readable and writable.

### 6.3 TCC/WDT and Prescaler

There are two 8-bit counters available as prescalers for the TCC and WDT respectively. The PST0~PST2 bits of the CONT register are used to determine the ratio of the prescaler of TCC. Likewise, the PSW0~PSW2 bits of the IOCA register are used to determine the WDT prescaler. The prescaler counter will be cleared by the instructions each time they are written into TCC. The WDT and prescaler will be cleared by the “WDTC” and “SLEP” instructions. Figure 6-9 depicts the circuit diagram of TCC/WDT.

R1 (TCC) is an 8-bit timer/counter. The clock source of TCC can be the internal clock or the external signal input (edge selectable from the TCC pin). If TCC signal source is from the internal clock, TCC will be incremented by 1 at Fc clock (without prescaler). As illustrated in Figure 6-9, selection of Fc depends on the bank 0 RE.6 <TIMERSC>. If TCC signal source is from external clock input, TCC will be incremented by 1 at every falling edge or rising edge of the TCC pin. TCC pin input time length (kept in High or low level) must be greater than 1CLK. The TCC will stop running when sleep mode occurs.

The watchdog timer is a free running on-chip RC oscillator. The WDT will keep on running even after the oscillator driver has been turned off (i.e. in sleep mode). During normal operation or sleep mode, a WDT time-out (if enabled) will cause the device to reset. The WDT can be enabled or disabled at any time during normal mode by software programming. Refer to WDTE bit of IOCA register. With no prescaler, the WDT time-out period is approximately 16.5 ms<sup>1</sup> (one oscillator start-up timer period).

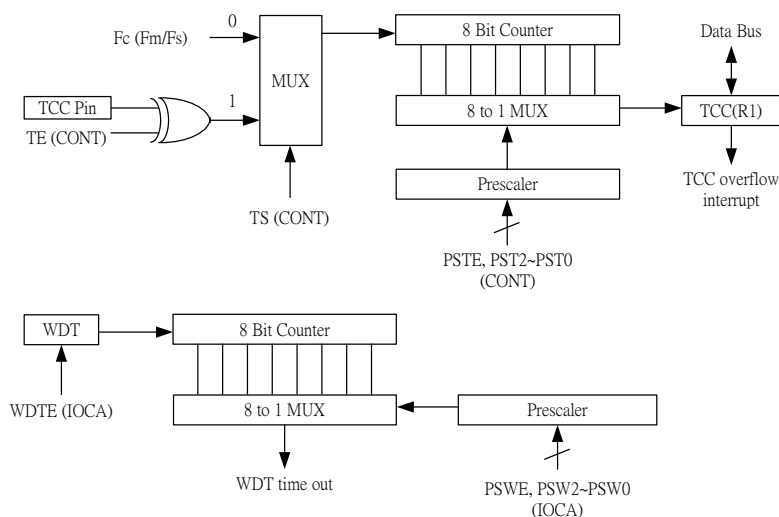
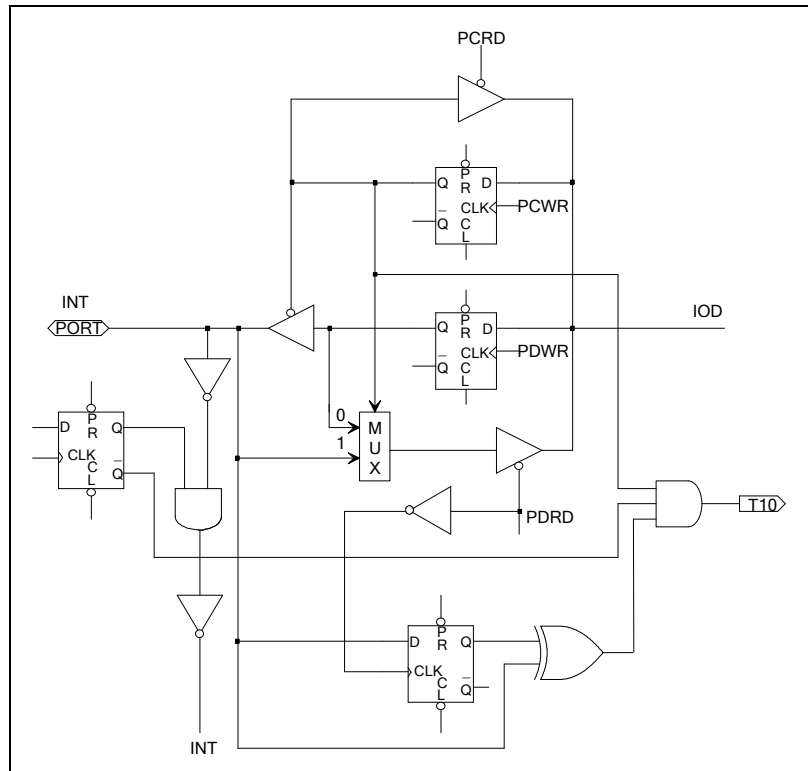

Figure 6-9 TCC and WDT Block Diagram

<sup>1</sup> VDD=5V, WDT time-out period = 16.5ms ± 5% VDD=3V  
WDT time-out period = 16.5ms ± 5%.





**Note:** Pull-high (down) and Open-drain are not shown in the figure.  
Figure 6-11 (a) I/O Port and I/O Control Register Circuit for P60 (INT)

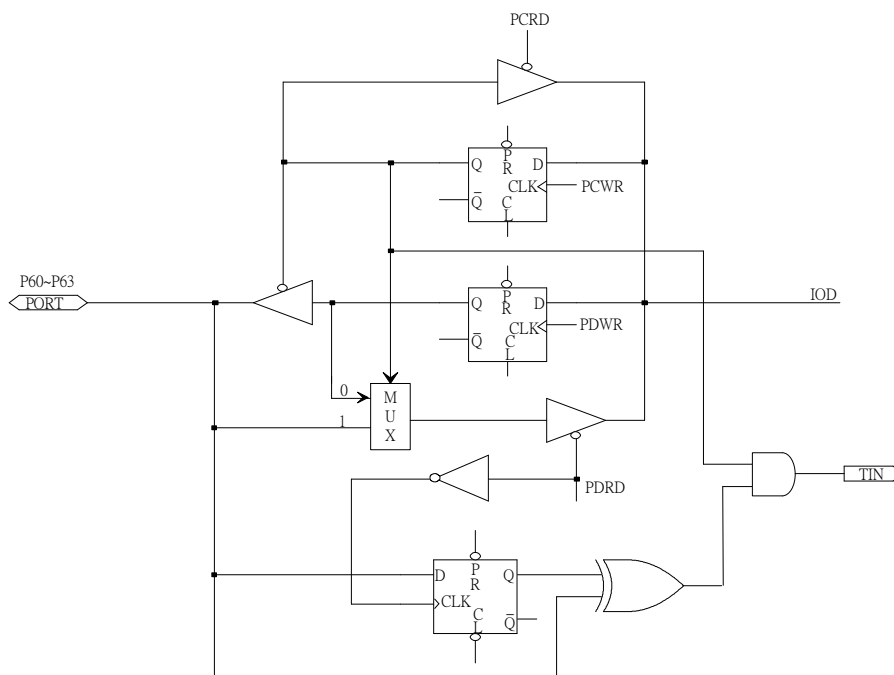

**Note:** Pull-high (down) and Open-drain are not shown in the figure.  
Figure 6-11 (b) I/O Port and I/O Control Register Circuit for P61~P63, P83

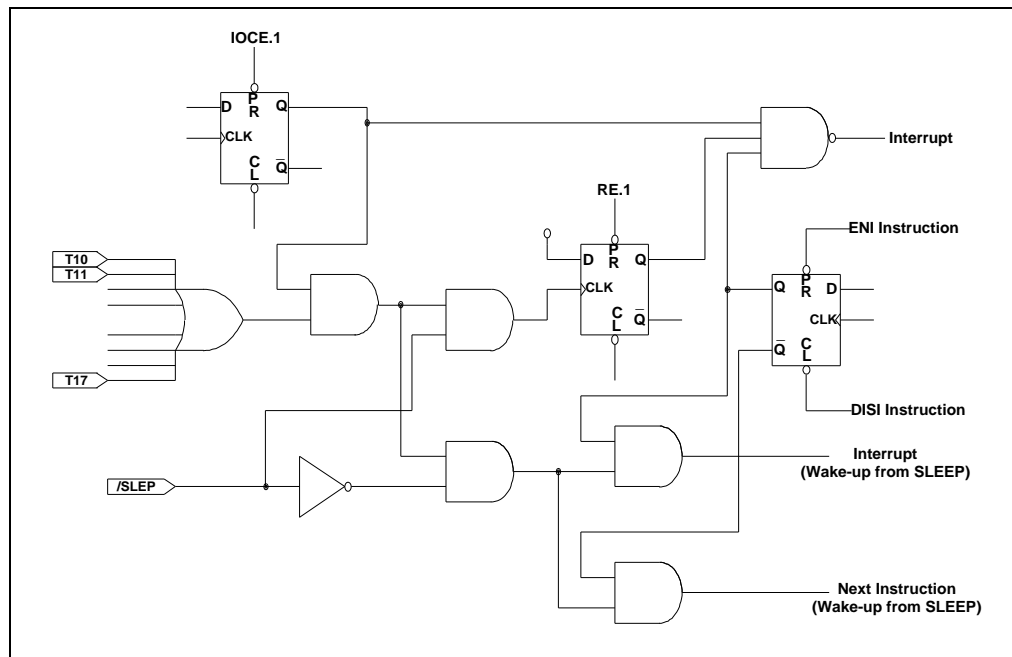

Figure 6-12 Block Diagram of I/O Port 6 with Input Change Interrupt/Wake-up

Table 6-1 Usage of Port 6 Input Change Wake-up/Interrupt Function

Usage of Port 6 Input Status Changed Wake-up/Interrupt	
<p><b>(I) Wake-up Input Status Change</b></p> <p><b>(a) Before Sleep</b></p> <ol style="list-style-type: none"> <li>1. Disable WDT<sup>2</sup> (use this very carefully)</li> <li>2. Read I/O Port 6 (MOV R6,R6)</li> <li>3 a. Enable interrupt (Set IOCF=1), after wake-up if "ENI" switch to interrupt vector (006H), if "DISI" excute next instruction</li> <li>3 b. Disable interrupt (Set IOCF=1). Always execute next instruction</li> <li>4. Enable wake-up bit (Set RA=6)</li> <li>5. Execute "SLEP" instruction</li> </ol> <p><b>(b) After Wake-up</b></p> <ol style="list-style-type: none"> <li>1. If "NI" → Interrupt Vector (006H)</li> <li>2. If "DSI" → Next instruction</li> </ol>	<p><b>(II) Interrupt Input Status Change</b></p> <ol style="list-style-type: none"> <li>1. Read I/O Port 6 (MOV R6,R6)</li> <li>2. Execute "NI"</li> <li>3. Enable interrupt (Set IOCF=1)</li> <li>4. If Port 6 change (Interrupt) → Interrupt Vector (006H)</li> </ol>

<sup>2</sup> Software disables WDT (watchdog timer) but hardware must be enabled before applying Port 6 Change Wake-up function (Code Option Register Word 0 Bit 6 (ENWDTB) is set to "1").

<sup>3</sup> Vdd = 5V, set up time period = 16.5ms ± 5%  
Vdd = 3V, set up time period = 16.5ms ± 5%

## 6.5 Reset and Wake-up

### 6.5.1 Reset

A reset is initiated by one of the following events:

- (1) Power-on reset
- (2) /RESET pin input “low”
- (3) WDT time-out (if enabled)

The device is kept in a reset condition for a period of approximately 18ms<sup>3</sup> (one oscillator start-up timer period) after the reset is detected. Once a reset occurs, the following functions are performed.

- The oscillator is running, or will be started.
- The Program Counter (R2) is set to all “0”.
- All I/O port pins are configured as input mode (high-impedance state).
- The Watchdog timer and prescaler are cleared.
- When power is switched on, the upper three bits of R3 are cleared.
- The bits of the RB, RC, RD, RD, RE registers are set to their previous status.
- The bits of the CONT register are set to all “0” except for Bit 6 (INT flag).
- The bits of the Pull-high, Pull-down.
- Bank 0 RF, IOCF registers are cleared.

Sleep (power down) mode is asserted by executing the “SLEP” instruction. While entering sleep mode, WDT (if enabled) is cleared but keeps on running. After a wake-up, in RC mode the wake-up time is 16 clocks.

The controller can be awakened by:

- (1) External reset input on /RESET pin
- (2) WDT time-out (if enabled)
- (3) Port 6 input status changes (if enabled)
- (4) External (P60 / INT) pin changes (if EXWE is enabled)
- (5) A/D conversion completed (if ADWE is enabled)

---

<sup>3</sup>  $V_{dd} = 5V$ , set up time period =  $16.5ms \pm 5\%$   
 $V_{dd} = 3V$ , set up time period =  $16.5ms \pm 5\%$

The first two events (1 & 2) will cause the EM78F734N to reset. The T and P flags of R3 can be used to determine the source of the reset (wake-up). Events 3, 4, and 5 are considered the continuation of program execution and the global interrupt “NI” or “DSI” (being executed) determines whether or not the controller branches to the interrupt vector following wake-up. If ENI is executed before SLEP, the instruction will begin to execute from Address 0x3, 0x6 0xF, 0x15 or 0X30, after wake-up. If DISI is executed before SLEP, the execution will restart from the instruction right next to SLEP after wake-up. All throughout the sleep mode, wake-up time is 150  $\mu$ s, no matter what oscillation mode (except low Crystal mode). In low Crystal 2 mode, wake-up time is 500ms.

One or more of the above Events 3 to 6 can be enabled before entering into sleep mode but is awakened only by one of the events.

[a] If WDT is enabled before SLEP, all of the RE bit is disabled. Hence, the EM78F734N can be awakened only by Event 1 or 2. Refer to Section 6.6 *Interrupt* for further details.

[b] If Port 6 Input Status Change is used to wake up the EM78F734N and the ICWE bit of the RA register is enabled before SLEP, WDT must be disabled. Hence, the EM78F734N can be awakened only by Event 3. The following instructions must be executed before SLEP:

```

MOV      A, @001110xxb ;Select WDT prescaler and disable WDT
IOW      IOCA
WDTC                                ;Clear WDT and prescaler
MOV      R6, R6 ;Read Port 6
ENI (or DISI) ;Enable (or disable) global interrupt
MOV      A, @010xxxxxb ;Enable Port 6 input change Wake-up bit
MOV      RA,A
MOV      A, @00000x1xb ;Enable Port 6 input change interrupt
IOW      IOCF
SLEP                                ;Sleep

```

[c] If External (P60/INT) pin changes is used to wake-up the EM78F734N and EXWE bit of the RA register is enabled before SLEP, WDT must be disabled by software. Hence, the EM78F734N can be awakened only by Event 4.

[d] If AD conversion completed is used to wake-up EM78F734N and ADWE bit of the RA register is enabled before SLEP, the WDT must be disabled by software. Hence, the EM78F734N can be waken-up only by Event 5.

## 6.5.2 Summary of Wake-up and Interrupt Modes Operation

All categories under Wake-up and Interrupt modes are summarized below.

The controller can be awakened from Sleep mode and Idle mode. The Wake-up signals are listed as follows.

Wake-up Signal	Sleep Mode	Idle Mode	Green Mode	Normal Mode
External interrupt	If enable EXWE bit Wake-up + interrupt (if interrupt is enabled) + next instruction	If enable EXWE bit Wake-up + interrupt (if interrupt is enablee) + next instruction	Interrupt (if interrupt is enabled) or next instruction	Interrupt (if interrupt is enabled) or next instruction
Port 6 pin change	If enable ICWE bit Wake-up + interrupt (if interrupt is enabled) + next instruction	If enable ICWE bit Wake-up + interrupt (if interrupt is enabled) + next instruction	Interrupt (if interrupt is enabled) or next instruction	Interrupt (if interrupt is enabled) or next instruction
TCC overflow interrupt	x	Wake-up + interrupt (if interrupt is enabled) + next instruction	Interrupt (if interrupt is enabled) or next instruction	Interrupt (if interrupt is enabled) or next instruction
AD conversion complete interrupt	If enable ADWE bit Wake-up + interrupt (if interrupt is enabled) + next instruction <b>Fs and Fm don't stop</b>	If enable ADWE bit Wake-up + interrupt (if interrupt is enabled) + next instruction <b>Fs and Fm don't stop</b>	Interrupt (if interrupt is enabled) or next instruction <b>Fs and Fm don't stop</b>	Interrupt (if interrupt is enabled) or next instruction
TC2 interrupt	x	Wake-up + interrupt (if interrupt is enabled) + next instruction	Interrupt (if interrupt is enabled) or next instruction	Interrupt (if interrupt is enabled) or next instruction
TC3 interrupt	x	Wake-up + interrupt (if interrupt is enabled) + next instruction	Interrupt (if interrupt is enabled) or next instruction	Interrupt (if interrupt is enabled) or next instruction
WDT Time out	RESET	RESET	RESET	RESET
Low Voltage Reset	RESET	RESET	RESET	RESET

After wake up:

1. If interrupt is enabled → interrupt+ next instruction
2. If interrupt is disabled → next instruction

### 6.5.3 Summary of Register Initial Values

**Legend:** *x*: Not used

*P*: Previous value before reset

*U*: Unknown or don't care

*t*: Check tables under Section 6.5.4

Addr	Name	Reset Type	Bit 7	Bit 6	Bit 5	Bit 4	Bit 3	Bit 2	Bit 1	Bit 0
0x05	IOC5	Bit Name	C57	-	C55	C54	C53	C52	C51	C50
		Power-on	1	0	1	1	1	1	1	1
		/RESET and WDT	1	0	1	1	1	1	1	1
		Wake-up from Pin Change	P	0	P	P	P	P	P	P
0x06	IOC6	Bit Name	-	-	-	-	C63	C62	C61	C60
		Power-on	0	0	0	0	1	1	1	1
		/RESET and WDT	0	0	0	0	1	1	1	1
		Wake-up from Pin Change	0	0	0	0	P	P	P	P
0x07	IOC7	Bit Name	C77	-	-	C74	C73	C72	C71	C70
		Power-on	1	0	0	1	1	1	1	1
		/RESET and WDT	1	0	0	1	1	1	1	1
		Wake-up from Pin Change	P	0	0	P	P	P	P	P
0x08	IOC8	Bit Name	-	-	-	-	C83	-	-	-
		Power-on	0	0	0	0	1	0	0	0
		/RESET and WDT	0	0	0	0	1	0	0	0
		Wake-up from Pin Change	0	0	0	0	P	0	0	0
N/A	CONT	Bit Name	INTE	/INT	TS	TE	PSTE	PST2	PST1	PST0
		Power-on	0	0	0	0	0	0	0	0
		/RESET and WDT	0	0	0	0	0	0	0	0
		Wake-up from Pin Change	P	P	P	P	P	P	P	P
0x00	R0 (IAR)	Bit Name	IAR7	IAR6	IAR5	IAR4	IAR3	IAR2	IAR1	IAR0
		Power-on	U	U	U	U	U	U	U	U
		/RESET and WDT	P	P	P	P	P	P	P	P
		Wake-up from Pin Change	P	P	P	P	P	P	P	P
0x01	R1 (TCC)	Bit Name	TCC7	TCC6	TCC5	TCC4	TCC3	TCC2	TCC1	TCC0
		Power-on	0	0	0	0	0	0	0	0
		/RESET and WDT	0	0	0	0	0	0	0	0
		Wake-up from Pin Change	P	P	P	P	P	P	P	P
0x02	R2 (PC)	Bit Name	A7	A6	A5	A4	A3	A2	A1	A0
		Power-on	0	0	0	0	0	0	0	0
		/RESET and WDT	0	0	0	0	0	0	0	0
		Wake-up from Pin Change	P	P	P	P	P	P	P	P
0x03	R3 (SR)	Bit Name	-	-	-	T	P	Z	DC	C
		Power-on	0	0	0	1	1	U	U	U
		/RESET and WDT	0	0	0	t	t	P	P	P
		Wake-up from Pin Change	0	0	0	t	t	P	P	P
0x04	R4 (RSR)	Bit Name	RSR7	RSR6	RSR5	RSR4	RSR3	RSR2	RSR1	RSR0
		Power-on	U	U	U	U	U	U	U	U
		/RESET and WDT	P	P	P	P	P	P	P	P
		Wake-up from Pin Change	P	P	P	P	P	P	P	P

Addr	Name	Reset Type	Bit 7	Bit 6	Bit 5	Bit 4	Bit 3	Bit 2	Bit 1	Bit 0
0x05	P5 (Bank 0)	Bit Name	P57	-	P55	P54	P53	P52	P51	P50
		Power-on	1	0	1	1	1	1	1	1
		/RESET and WDT	1	0	1	1	1	1	1	1
		Wake-up from Pin Change	P	0	P	P	P	P	P	P
0x06	P6 (Bank 0)	Bit Name	-	-	-	-	P63	P62	P61	P60
		Power-on	0	0	0	0	1	1	1	1
		/RESET and WDT	0	0	0	0	1	1	1	1
		Wake-up from Pin Change	0	0	0	0	P	P	P	P
0x07	P7 (Bank 0)	Bit Name	P77	-	-	P74	P73	P72	P71	P70
		Power-on	1	0	0	1	1	1	1	1
		/RESET and WDT	1	0	0	1	1	1	1	1
		Wake-up from Pin Change	P	0	0	P	P	P	P	P
0x08	P8 (Bank 0)	Bit Name	-	-	-	-	P83	-	-	-
		Power-on	0	0	0	0	1	0	0	0
		/RESET and WDT	0	0	0	0	1	0	0	0
		Wake-up from Pin Change	0	0	0	0	P	0	0	0
0x09	R9 (Bank 0)	Bit Name	RBit7	RBit6	RBit5	RBit4	RBit3	RBit2	RBit1	RBit0
		Power-on	0	0	0	0	0	0	0	0
		/RESET and WDT	0	0	0	0	0	0	0	0
		Wake-up from Pin Change	P	P	P	P	P	P	P	P
0x0A	RA (Bank 0)	Bit Name	-	ICWE	ADWE	EXWE	-	-	-	-
		Power-on	0	0	0	0	0	0	0	0
		/RESET and WDT	0	0	0	0	0	0	0	0
		Wake-up from Pin Change	0	P	P	P	0	0	0	0
0x0B	RB (ECR) (Bank 0)	Bit Name	RD	WR	EEWE	EEDF	EEPC	-	-	-
		Power-on	0	0	0	0	0	0	0	0
		/RESET and WDT	P	P	P	P	P	0	0	0
		Wake-up from Pin Change	P	P	P	P	P	0	0	0
0x0C	RC (Bank 0)	Bit Name	-	EE_A6	EE_A5	EE_A4	EE_A3	EE_A2	EE_A1	EE_A0
		Power-on	0	0	0	0	0	0	0	0
		/RESET and WDT	0	P	P	P	P	P	P	P
		Wake-up from Pin Change	0	P	P	P	P	P	P	P
0x0D	RD (Bank 0)	Bit Name	EE_D7	EE_D6	EE_D5	EE_D4	EE_D3	EE_D2	EE_D1	EE_D0
		Power-on	0	0	0	0	0	0	0	0
		/RESET and WDT	P	P	P	P	P	P	P	P
		Wake-up from Pin Change	P	P	P	P	P	P	P	P
0x0E	RE (Bank 0)	Bit Name	-	TIMERS	CPUS	IDLE	-	-	-	-
		Power-on	0	1	1	1	0	0	0	0
		/RESET and WDT	0	1	1	1	0	0	0	0
		Wake-up from Pin Change	0	P	P	P	0	0	0	0



Addr	Name	Reset Type	Bit 7	Bit 6	Bit 5	Bit 4	Bit 3	Bit 2	Bit 1	Bit 0
0x0F	RF (ISR) (Bank 0)	Bit Name	-	ADIF	-	-	-	EXIF	ICIF	TCIF
		Power-on	0	0	0	0	0	0	0	0
		/RESET and WDT	0	0	0	0	0	0	0	0
		Wake-up from Pin Change	0	P	0	0	0	P	P	P
0x5	R5 (Bank 1)	Bit Name	TC1AP	TC1S	TC1M	TC1ES	TC1MOD	TCK1CK2	TC1CK1	TC1CK0
		Power-on	0	0	0	0	0	0	0	0
		/RESET and WDT	0	0	0	0	0	0	0	0
		Wake-up from Pin Change	P	P	P	P	P	P	P	P
0x6	R6 (Bank 1)	Bit Name	TC1DA7	TC1DA6	TC1DA5	TC1DA4	TC1DA3	TC1DA2	TC1DA1	TC1DA0
		Power-on	0	0	0	0	0	0	0	0
		/RESET and WDT	0	0	0	0	0	0	0	0
		Wake-up from Pin Change	P	P	P	P	P	P	P	P
0x7	R7 (Bank 1)	Bit Name	TC1DB7	TC1DB6	TC1DB5	TC1DB4	TC1DB3	TC1DB2	TC1DB1	TC1DB0
		Power-on	0	0	0	0	0	0	0	0
		/RESET and WDT	0	0	0	0	0	0	0	0
		Wake-up from Pin Change	P	P	P	P	P	P	P	P
0x8	R8 (Bank 1)	Bit Name	RCM1	RCM0	-	-	-	-	-	-
		Power-on	Option RCM1	Option RCM0	0	0	0	0	0	0
		/RESET and WDT	Option RCM1	Option RCM0	0	0	0	0	0	0
		Wake-up from Pin Change	P	P	0	0	0	0	0	0
0x9	R9 (Bank 1)	Bit Name	TC2DA7	TC2DA6	TC2DA5	TC2DA4	TC2DA3	TC2DA2	TC2DA1	TC2DA0
		Power-on	0	0	0	0	0	0	0	0
		/RESET and WDT	0	0	0	0	0	0	0	0
		Wake-up from Pin Change	P	P	P	P	P	P	P	P
0xA	RA (Bank 1)	Bit Name	TC2DB7	TC2DB6	TC2DB5	TC2DB4	TC2DB3	TC2DB2	TC2DB1	TC2DB0
		Power-on	0	0	0	0	0	0	0	0
		/RESET and WDT	0	0	0	0	0	0	0	0
		Wake-up from Pin Change	P	P	P	P	P	P	P	P
0xF	RF (Bank 1)	Bit Name	-	-	TCIF3	-	TCIF1	-	-	-
		Power-on	0	0	0	0	0	0	0	0
		/RESET and WDT	0	0	0	0	0	0	0	0
		Wake-up from Pin Change	0	0	P	0	P	0	0	0
0x05	R5 (Bank 2)	Bit Name	ADE7	ADE6	ADE5	ADE4	ADE3	ADE2	ADE1	ADE0
		Power-on	0	0	0	0	0	0	0	0
		/RESET and WDT	0	0	0	0	0	0	0	0
		Wake-up from Pin Change	P	P	P	P	P	P	P	P



Addr	Name	Reset Type	Bit 7	Bit 6	Bit 5	Bit 4	Bit 3	Bit 2	Bit 1	Bit 0
0x06	R6 (Bank 2)	Bit Name	VREFS	CKR1	CKR0	ADRUN	ADPD	ADIS2	ADIS1	ADIS0
		Power-on	0	0	0	0	0	0	0	0
		/RESET and WDT	0	0	0	0	0	0	0	0
		Wake-up from Pin Change	P	P	P	P	P	P	P	P
0x7	R7 (Bank 2)	Bit Name	-	-	-	-	-	PDE	-	-
		Power-on	0	0	0	0	0	0	0	0
		/RESET and WDT	0	0	0	0	0	0	0	0
		Wake-up from Pin Change	0	0	0	0	0	P	0	0
0x8	R8 (Bank 2)	Bit Name	ADD11	ADD10	ADD9	ADD8	ADD7	ADD6	ADD5	ADD4
		Power-on	0	0	0	0	0	0	0	0
		/RESET and WDT	0	0	0	0	0	0	0	0
		Wake-up from Pin Change	P	P	P	P	P	P	P	P
0x9	R9 (Bank 2)	Bit Name	-	-	IRVS1	IRVS0	ADD3	ADD2	ADD1	ADD0
		Power-on	0	0	0	0	0	0	0	0
		/RESET and WDT	0	0	0	0	0	0	0	0
		Wake-up from Pin Change	0	0	P	P	P	P	P	P
0x0F	RF (Bank 2)	Bit Name	-	-	-	-	/PH73	/PH72	/PH71	/PH70
		Power-On	0	0	0	0	1	1	1	1
		/RESET and WDT	0	0	0	0	1	1	1	1
		Wake-up from Pin Change	0	0	0	0	P	P	P	P
0X06	R6 (Bank 3)	Bit Name	MLB	-	-	-	RBit 11	RBit 10	RBit 9	RBit 8
		Power-On	0	0	0	0	0	0	0	0
		/RESET and WDT	0	0	0	0	0	0	0	0
		Wake-up from Pin Change	P	0	0	0	P	P	P	P
0XD	RD (Bank 3)	Bit Name	TC3FF1	TC3FF0	TC3S	TC3CK2	TC3CK1	TC3CK0	TC3M1	TC3M0
		Power-on	0	0	0	0	0	0	0	0
		/RESET and WDT	0	0	0	0	0	0	0	0
		Wake-up from Pin Change	P	P	P	P	P	P	P	P
0XE	RE (Bank 3)	Bit Name	TC3D7	TC3D6	TC3D5	TC3D4	TC3D3	TC3D2	TC3D1	TC3D0
		Power-on	0	0	0	0	0	0	0	0
		/RESET and WDT	0	0	0	0	0	0	0	0
		Wake-up from Pin Change	P	P	P	P	P	P	P	P
0XF	RF (Bank 3)	Bit Name	-	-	-	-	/PD73	/PD72	/PD71	/PD70
		Power-on	0	0	0	0	1	1	1	1
		/RESET and WDT	0	0	0	0	1	1	1	1
		Wake-up from Pin Change	0	0	0	0	P	P	P	P

(Continuation)

Addr	Name	Reset Type	Bit 7	Bit 6	Bit 5	Bit 4	Bit 3	Bit 2	Bit 1	Bit 0
0x0A	IOCA	Bit Name	WDTE	EIS	-	-	PSWE	PSW2	PSW1	PSW0
		Power-on	0	0	0	0	0	0	0	0
		/RESET and WDT	0	0	0	0	0	0	0	0
		Wake-up from Pin Change	P	P	0	0	P	P	P	P
0x0B	IOCB	Bit Name	/PD7	/PD6	/PD5	/PD4	/PD3	/PD2	/PD1	/PD0
		Power-on	1	1	1	1	1	1	1	1
		/RESET and WDT	1	1	1	1	1	1	1	1
		Wake-up from Pin Change	P	P	P	P	P	P	P	P
0x0C	IOCC	Bit Name	-	-	-	-	OD3	OD2	OD1	OD0
		Power-on	0	0	0	0	0	0	0	0
		/RESET and WDT	0	0	0	0	0	0	0	0
		Wake-up from Pin Change	0	0	0	0	P	P	P	P
0x0D	IOCD	Bit Name	-	-	-	-	/PH3	/PH2	/PH1	/PH0
		Power-on	0	0	0	0	1	1	1	1
		/RESET and WDT	0	0	0	0	1	1	1	1
		Wake-up from Pin Change	0	0	0	0	P	P	P	P
0x0E	IOCE	Bit Name	-	-	TCIE3	-	TCIE1	-	-	-
		Power-on	0	0	0	0	0	0	0	0
		/RESET and WDT	0	0	0	0	0	0	0	0
		Wake-up from Pin Change	0	0	P	0	P	0	0	0
0x0F	IOCF	Bit Name	-	ADIE	-	-	-	EXIE	ICIE	TCIE
		Power-on	0	0	0	0	0	0	0	0
		/RESET and WDT	0	0	0	0	0	0	0	0
		Wake-up from Pin Change	0	P	0	0	0	P	P	P
0x10~ 0x2F	R10~ R2F	Bit Name	R7	R6	R5	R4	R3	R2	R1	R0
		Power-on	U	U	U	U	U	U	U	U
		/RESET and WDT	P	P	P	P	P	P	P	P
		Wake-up from Pin Change	P	P	P	P	P	P	P	P

#### 6.5.4 Status of RST, T, and P of the Status Register

A reset condition is initiated by the following events:

1. Power-on condition
2. High-low-high pulse on /RESET pin
3. Watchdog timer time-out

The values of T and P, listed in the first table below are used to check how the processor wakes up. The second table shows the events that may affect the status of T and P.

##### ■ Values of RST, T and P after Reset

Reset Type	T	P
Power on	1	1
/RESET during Operating mode	*P	*P
/RESET wake-up during Sleep mode	1	0
WDT during Operating mode	0	*P
WDT wake-up during Sleep mode	0	0
Wake-up on pin change during Sleep mode	1	0

\*P: Previous status before reset

##### ■ Status of T and P Being Affected by Events

Event	T	P
Power on	1	1
WDTC instruction	1	1
WDT time-out	0	*P
SLEP instruction	1	0
Wake-up on pin change during Sleep mode	1	0

\*P: Previous value before reset

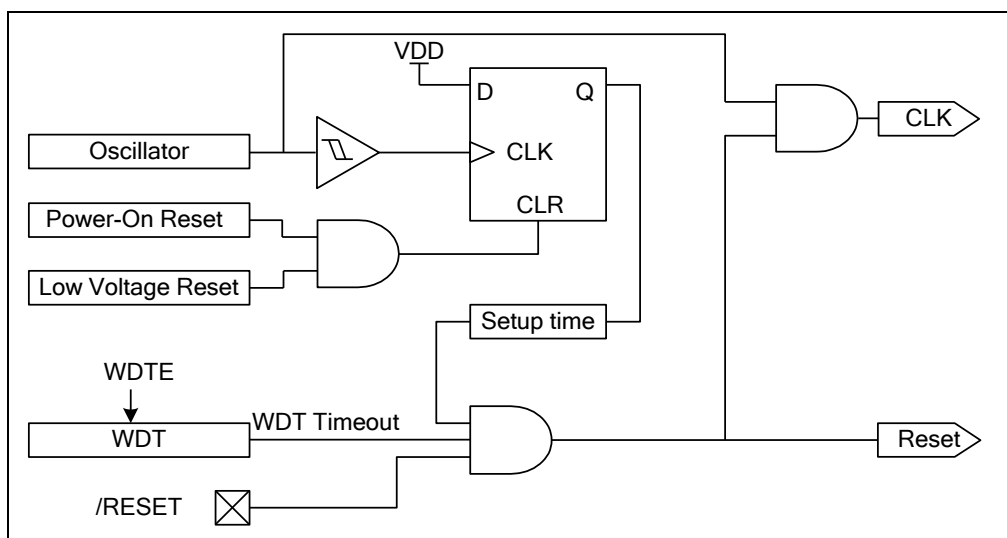

Figure 6-13 Controller Reset Block Diagram

## 6.6 Interrupt

The EM78F734N has eight interrupts (four external, four internal) as listed below:

Interrupt Source	Enable Condition	Int. Flag	Int. Vector	Priority	
Internal / External	Reset	-	0000	High 0	
External	INT	ENI + EXIE=1	EXIF	0003	1
External	Port 6 pin change	ENI + ICIE=1	ICIF	0006	2
Internal	TCC	ENI + TCIE=1	TCIF	0009	3
Internal	TC1	ENI + TCIE1=1	TCIF1	0018	4
Internal	TC3	ENI + TCIE3=1	TCIF3	0027	5
Internal	AD	ENI + ADIE=1	ADIF	0030	6

RF is interrupt status register that records the interrupt requests in the relative flags/bits. IOCF is interrupt mask register. The global interrupt is enabled by the ENI instruction and is disabled by the DISI instruction. When one of the enabled interrupts occur, the next instruction will be fetched from their individual address. The interrupt flag bit must be cleared by instructions before leaving the interrupt service routine and before interrupts are enabled to avoid recursive interrupts.

The flag (except ICIF bit) in the Interrupt Status Register (RF) is set regardless of the status of its mask bit or the execution of ENI. The RETI instruction ends the interrupt routine and enables the global interrupt (the execution of ENI).

The external interrupt is equipped with an on-chip digital noise rejection circuit (input pulse less than **8 system clock time** is eliminated as noise). When an interrupt (Falling edge) is generated by the External interrupt (when enabled), the next instruction will be fetched from Address 003H.

Before the interrupt subroutine is executed, the contents of ACC and the R3 and R4 register will be saved by hardware. If another interrupt occurred, the ACC, R3 and R4 will be replaced by the new interrupt. After the interrupt service routine is finished, ACC, R3 and R4 will be pushed back.

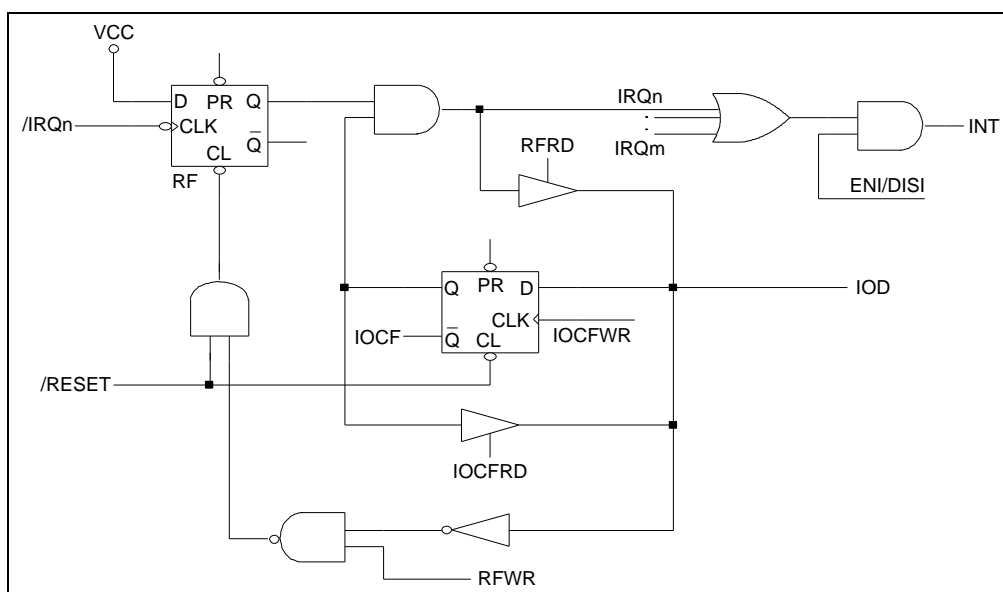

Figure 6-14 Interrupt Input Circuit

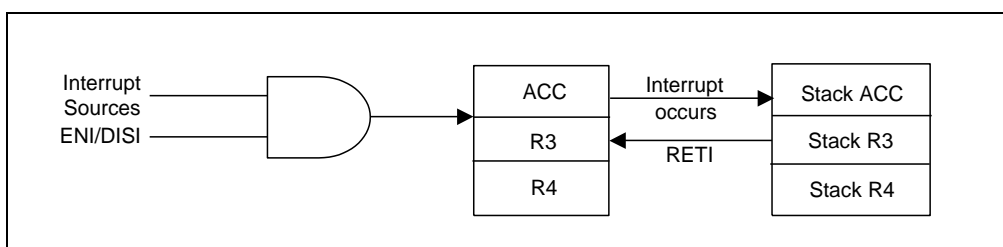

Figure 6-15 Interrupt Back-up Diagram

## 6.7 Data EEPROM

The Data EEPROM is readable and writable during normal operation over the whole Vdd range. The operation for Data EEPROM is based on a single byte. A write operation makes an erase-then-write cycle to take place on the allocated byte.

The Data EEPROM memory provides high erase and write cycles. A byte write automatically erases the location and writes the new value.

### 6.7.1 Data EEPROM Control Register

#### 6.7.1.1 RB (EEPROM Control Register)

The EECR (EEPROM Control Register) is the control register for configuring and initiating the control register status.

Bit 7	Bit 6	Bit 5	Bit 4	Bit 3	Bit 2	Bit 1	Bit 0
RD	WR	EEWE	EEDF	EEPC	-	-	-

- Bit 7 (RD):** Read control register
- 0 : Does not execute EEPROM read
  - 1 : Read EEPROM content, (RD can be set by software, RD is cleared by hardware after Read instruction is completed)
- Bit 6 (WR):** Write control register
- 0 : Write cycle to the EEPROM is completed.
  - 1 : Initiate a write cycle, (WR can be set by software, WR is cleared by hardware after Write cycle is completed)
- Bit 5 (EEWE):** EEPROM Write Enable bit
- 0 : Write to the EEPROM is prohibited.
  - 1 : Allows EEPROM write cycles
- Bit 4 (EEDF):** EEPROM Detect Flag
- 0 : Write cycle is completed
  - 1 : Write cycle is unfinished
- Bit 3 (EEPC):** EEPROM power-down control bit
- 0 : Switch off the EEPROM
  - 1 : EEPROM is operating
- Bits 2 ~ 0:** Not used, set to "0" at all time

### 6.7.1.2 RC (128 Bytes EEPROM Address)

When accessing the EEPROM data memory, the RC (128 bytes EEPROM address register) holds the address to be accessed. In accordance with the operation, the RD (128 bytes EEPROM Data register) holds the data to be written, or the data read, at the address in RC.

Bit 7	Bit 6	Bit 5	Bit 4	Bit 3	Bit 2	Bit 1	Bit 0
-	EE_A6	EE_A5	EE_A4	EE_A3	EE_A2	EE_A1	EE_A0

**Bit 7:** Not used, set to “0” at all time.

**Bits 6 ~ 0:** 128 bytes EEPROM address

### 6.7.1.3 RD (256 Bytes EEPROM Data)

Bit 7	Bit 6	Bit 5	Bit 4	Bit 3	Bit 2	Bit 1	Bit 0
EE_D7	EE_D6	EE_D5	EE_D4	EE_D3	EE_D2	EE_D1	EE_D0

**Bits 7 ~ 0:** 128 bytes EEPROM data

## 6.7.2 Programming Step / Example Demonstration

### 6.7.2.1 Programming Step

Follow these steps to write to or read data from the EEPROM:

**Step 1** Set the RB.EEPC bit to “1” to enable the EEPROM power.

**Step 2** Write the address to RC (128 bytes EEPROM address).

1. (a) Set the RB.EEWE bit to 1, if the write function is employed.  
(b) Write the 8-bit data value to be programmed in the RD (256 bytes EEPROM data)(c) Set the RB.WR bit to “1”, then execute the write function.

2. Set the RB.READ bit to “1”, after which, execute the read function.

**Step 3** Wait for the RB.EEDF or RB.WR to be cleared

**Step 4** For the next conversion, go to Step 2 as required.

**Step 5** If you want to save power, make sure the EEPROM data is not used by clearing the RB.EEPC.

### 6.7.2.2 Example Demonstration Programs

```

; Define the control register and write data to EEPROM
RC == 0x0C
RB == 0x0B
RD == 0x0D
Read == 0x07
WR == 0x06
EEWE == 0x05
EEDF == 0x04
EEPC == 0x03

BS RB, EEPC      ; Set the EEPROM power on
MOV A, @0x0A
MOV RC, A        ; Assign the address from EEPROM
BS RB, EEWE      ; Enable the EEPROM write function
MOV A, @0x55
MOV RD, A        ; Set the data for EEPROM
BS RB, WR        ; Write value to EEPROM
JBC RB, EEDF     ; Check whether the EEPROM bit is completed or not
JMP $-1

```

## 6.8 Analog-to-Digital Converter (ADC)

The analog-to-digital circuitry consists of a 9-bit analog multiplexer, three control registers (AISR/R5 (Bank 2), ADCON/R6 (Bank 2), ADOC/R7 (Bank 2)), two data registers (ADDH, ADDL/R8, R9) and an ADC with 12-bit resolution. The analog reference voltage ( $V_{ref}$ ) and analog ground are connected via separate input pins. The functional block diagram of the ADC is shown below.

The ADC module utilizes successive approximation to convert the unknown analog signal into a digital value. The result is fed to the ADDH and ADDL. Input channels are selected by the analog input multiplexer via the ADCON register Bits ADIS2, ADIS1 and ADIS0.

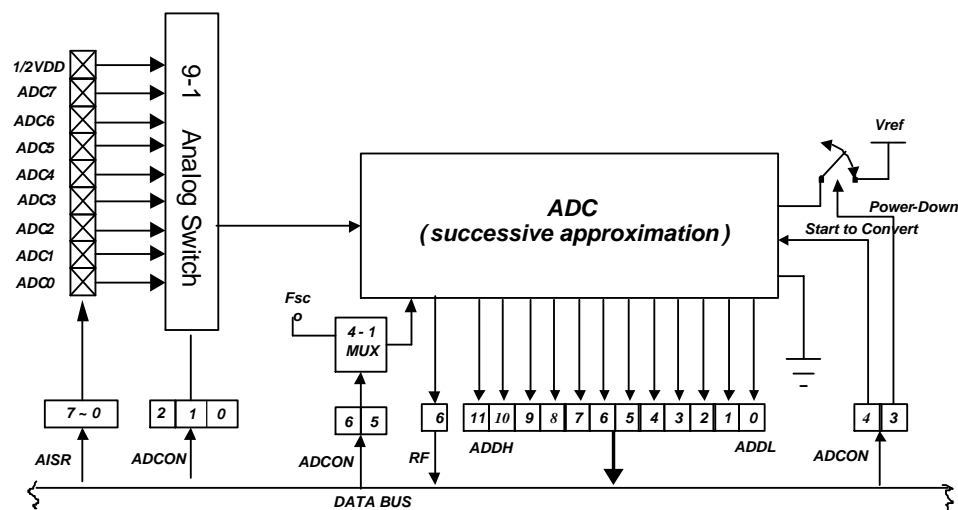

Figure 6-16 Functional Block Diagram of Analog-to-Digital Conversion

### 6.8.1 ADC Control Register (AISR/R5, ADCON/R6, ADOC/R7)

### 6.8.2 Bank 2 R5 AISR (ADC Input Select Register)

The AISR register defines the ADC pins as analog input or as digital I/O.

Bit 7	Bit 6	Bit 5	Bit 4	Bit 3	Bit 2	Bit 1	Bit 0
ADE7	ADE6	ADE5	ADE4	ADE3	ADE2	ADE1	ADE0

**Bit 7 (ADE7):** AD converter enable bit of P57 pin.

0 : Disable ADC7, P57 functions as I/O pin.

1 : Enable ADC7 to function as analog input pin

**Bit 6 (ADE6):** AD converter enable bit of P74 pin.

0 : Disable ADC6, P74 functions as I/O pin.

1 : Enable ADC6 to function as analog input pin

**Bit 5 (ADE5):** AD converter enable bit of P77 pin

0 : Disable ADC5, P77 functions as I/O pin

1 : Enable ADC5 to function as analog input pin

**Bit 4 (ADE4):** AD converter enable bit of P73 pin

0 : Disable ADC4, P73 functions as I/O pin

1 : Enable ADC4 to function as analog input pin

**Bit 3 (ADE3):** AD converter enable bit of P63 pin.

0 : Disable ADC3, P63 functions as I/O pin

1 : Enable ADC3 to function as analog input pin

**Bit 2 (ADE2):** AD converter enable bit of P62 pin.

0 : Disable ADC2, P62 functions as I/O pin

1 : Enable ADC2 to function as analog input pin

**Bit 1 (ADE1):** AD converter enable bit of P61 pin

0 : Disable ADC1, P61 functions as I/O pin

1 : Enable ADC1 to function as analog input pin

**Bit 0 (ADE0):** AD converter enable bit of P60 pin

0 : Disable ADC0, P60 functions as I/O pin

1 : Enable ADC0 to function as analog input pin

The following table shows the priority of P60/AD0//INT.

P60/AD0//INT Pin Priority		
High	Medium	Low
/INT	AD0	P60

### 6.8.3 Bank 2 R6 ADCON (A/D Control Register)

Bit 7	Bit 6	Bit 5	Bit 4	Bit 3	Bit 2	Bit 1	Bit 0
VREFS	CKR1	CKR0	ADRUN	ADPD	ADIS2	ADIS1	ADIS0

**Bit 7 (VREFS):** Input source of the Vref of the ADC.

**0 :** Vref of the ADC is connected to the internal reference which is selected by Bank 2 R9<5,4> (default value), and the P50/VREF pin carries out the function of P50

**1 :** Vref of the ADC is connected to P50/VREF

**Bit 6 ~ Bit 5 (CKR1 ~ CKR0):** Prescaler of oscillator clock rate of ADC

CKR1/CKR0	Operation Mode	Max. Operation Frequency
00	$F_{osc}/4$	4 MHz
01	$F_{osc}$	1 MHz
10	$F_{osc}/16$	8 MHz
11	$F_{osc}/2$	1 MHz

**Bit 4 (ADRUN):** ADC starts to run

**0 :** Reset upon completion of AD conversion. This bit cannot be reset by software.

**1 :** A/D conversion is started. This bit can be set by software.

**Bit 3 (ADPD):** ADC Power-down mode

**0 :** Switch off the resistor reference to save power even while the CPU is operating

**1 :** ADC is operating

**Bits 2~0 (ADIS2~ADIS0):** AD Input Select Bits

ADIS2	ADIS1	ADIS0	AD Input Pin
0	0	0	AD0
0	0	1	AD1
0	1	0	AD2
0	1	1	AD3
1	0	0	AD4
1	0	1	AD5
1	1	0	AD6
1	1	1	AD7

#### 6.8.4 Bank 2 R7 ADOC (A/D Offset Calibration Register)

Bit 7	Bit 6	Bit 5	Bit 4	Bit 3	Bit 2	Bit 1	Bit 0
-	-	-	-	-	PDE	Reserved	Reserved

Bits 7~3: Not used, set to “0” at all time.

**Bit 2 (PDE):** 1/2 VDD Power Detect Enable bit.

**0:** Disable Power Detect (Default)

**1:** Enable Power Detect.

PDE	ADIS2	ADIS1	ADIS0	AD Input Select
<b>1</b>	x	x	x	1/2VDD
<b>0</b>	x	x	x	ADx

Bits 1~0: Reserved, must be set to “0” at all time.

#### 6.8.5 ADC Data Buffer (ADDH, ADDL/R8, R9)

When the A/D conversion is completed, the result is loaded to the ADDH, ADDL. The ADRUN bit is cleared, and the ADIF is set.

#### 6.8.6 A/D Sampling Time

The accuracy, linearity, and speed of the successive approximation A/D converter are dependent on the properties of the ADC. The source impedance and the internal sampling impedance directly affect the time required to charge the sample holding capacitor. The application program controls the length of the sample time to meet the specified accuracy. Generally speaking, the program should wait for 2 $\mu$ s for each K $\Omega$  of the analog source impedance and at least 2 $\mu$ s for the low-impedance source. The maximum recommended impedance for analog source is 10K $\Omega$  at Vdd=5V. After the analog input channel is selected, this acquisition time must be done before the conversion can be started.

RCM[1:0]*	Frequency (MHz)	Sample and Hold Timing
00	4	8 x T <sub>AD</sub>
01	1	4 x T <sub>AD</sub>
10	8	12 x T <sub>AD</sub>
11	455k	2 x T <sub>AD</sub>

\*When using XT, LXT1, HXT1, HXT2 mode can also modify RCM[1:0] At Code Option Word 1 to set the Sample and Hold time.

### 6.8.7 A/D Conversion Time

CKR0 and CKR1 select the conversion time (Tct), in terms of instruction cycles. This allows the MCU to run at the maximum frequency without sacrificing the accuracy of A/D conversion. For the EM78F734N, the conversion time per bit is 1 $\mu$ s. The table below shows the relationship between Tct and the maximum operating frequencies.

#### ■ Tct vs. Maximum Operation Frequency

CKR0: CKR1	Operation Mode	Max. Operating Frequency	Max. Conversion Rate Per Bit	Max. Conversion Rate (12bit)
00	Fosc/4	4 MHz	1 MHz (1 $\mu$ s)	(12+8)*1 $\mu$ s=20 $\mu$ s (50kHz)
01	Fosc	1 MHz	1 MHz (1 $\mu$ s)	(12+4)*1 $\mu$ s=16 $\mu$ s(62.5kHz)
10	Fosc/16	8 MHz	0.5 MHz (2 $\mu$ s)	(12+12)*2 $\mu$ s=48 $\mu$ s (20.8kHz)
11	Fosc/2	1 MHz	0.5 MHz (2 $\mu$ s)	(12+4)*2 $\mu$ s=32 $\mu$ s (31.25kHz)

#### NOTE

- The pin that is not used as analog input can be used as regular input or output pin.
- During conversion, do not perform output instruction to maintain precision for all of the pins.

### 6.8.8 A/D Operation during Sleep Mode

In order to obtain a more accurate ADC value and reduced power consumption, the A/D conversion remains operational during sleep mode. As the SLEP instruction is executed, all the MCU operations will stop except for the Oscillator, TCC, TC1, TC3, and A/D conversion.

The AD Conversion is considered completed when:

- 1 ADRUN Bit of R6 Register is cleared to "0".
- 2 Wake-up from A/D Conversion remains in operation during Sleep Mode.

The result is fed to the ADDATA, ADOC when the conversion is completed. If the ADWE is enabled, the device will wake up. Otherwise, the A/D conversion will be shut off, no matter what the status of the ADPD bit is.

## 6.8.9 Programming Steps/Considerations

### 6.8.9.1 Programming Steps

Follow the following steps to obtain data from the ADC:

1. Write to the 8 bits (ADE7~ ADE0) on the R5 (AISR) register to define the characteristics of R6: Digital I/O, analog channels, and voltage reference pin.
2. Write to the R6/ADCON register to configure the AD module:
  - a. Select A/D input channel ( ADIS1 ~ ADIS0 ).
  - b. Define the A/D conversion clock rate ( CKR1 ~ CKR0 ).
  - c. Select the input source of the VREFS of the ADC.
  - d. Set the ADPD bit to “1” to begin sampling.
3. Set the ADWE bit, if the wake-up function is employed.
4. Set the ADIE bit, if the interrupt function is employed.
5. Put “ENI” instruction, if the interrupt function is employed.
6. Set the ADRUN bit to “1”.
7. Wait for wake-up or when ADRUN bit is cleared to “0”.
8. Read ADDATA, ADOC the conversion data register.
9. Clear the interrupt flag bit (ADIF) when A/D interrupt function occurs.
10. For the next conversion, repeat from Step 1 or Step 2 as required. At least 2 Tct is required before the next acquisition starts.

#### NOTE

*To obtain an accurate value, it is necessary to avoid any data transition on the I/O pins during AD conversion.*

### 6.8.9.2 Sample Demonstration Programs

*; To define the General Registers*

```
R_0 == 0 ; Indirect addressing register
PSW == 3 ; Status register
PORT5 == 5
PORT6 == 6
RE== 0XE ; Wake-up control resister
RF== 0XF ; Interrupt status register
```

*; To define the Control Register*

```
IOC50 == 0X5 ; Control Register of Port 5
IOC60 == 0X6 ; Control Register of Port 6
C_INT== 0XF ; Interrupt Control Register
```

```

; ADC Control Registers
ADDATA == 0x8           ; The contents are the results of ADC
AISR == 0x08           ; ADC output select register
ADCON == 0x6           ; 7   6   5   4   3   2   1   0
                       VREFS CKR1 CKR0 ADRUN ADPD
                       -   ADIS1 ADIS0

; To define bits
; In ADCON
ADRUN == 0x4           ; ADC is executed as the bit is set
ADPD == 0x3           ; Power Mode of ADC

; Program Starts
ORG 0                   ; Initial address
JMP INITIAL
ORG 0x30                ; Interrupt vector
(User program)
CLR RF                  ; To clear the ADIF bit
BS ADCON , ADRUN       ; To start to execute the next AD
                       ; conversion if necessary

RETI

INITIAL:
MOV A , @0B00000001    ; To define P60 as an analog input
MOV AISR , A
MOV A , @0B00001000    ; To select P60 as an analog input
                       ; channel, and AD power on
MOV ADCON , A         ; To define P60 as an input pin and
                       ; set clock rate at fosc/16

En_ADC:
MOV A , @0BXXXXXX1    ; To define P60 as an input pin, and
                       ; the others are dependent
                       ; on applications

IOW PORT6
MOV A , @0BXXXX1XXX   ; Enable the ADWE wake-up function
                       ; of ADC, "X" by application

MOV RE , A
MOV A , @0BXXXX1XXX   ; Enable the ADIE interrupt function
                       ; of ADC, "X" by application

IOW C_INT

ENI                     ; Enable the interrupt function
BS ADCON , ADRUN       ; Start to run the ADC

; If the interrupt function is ; employed, the following three lines
; may be ignored

POLLING:
JBC ADCON , ADRUN     ; To check the ADRUN bit ; continuously
JMP                ; ADRUN bit will be reset as the AD
POLLING              ; conversion is completed
;
(User program)
;

```

## 6.9 Timer/Counter 1

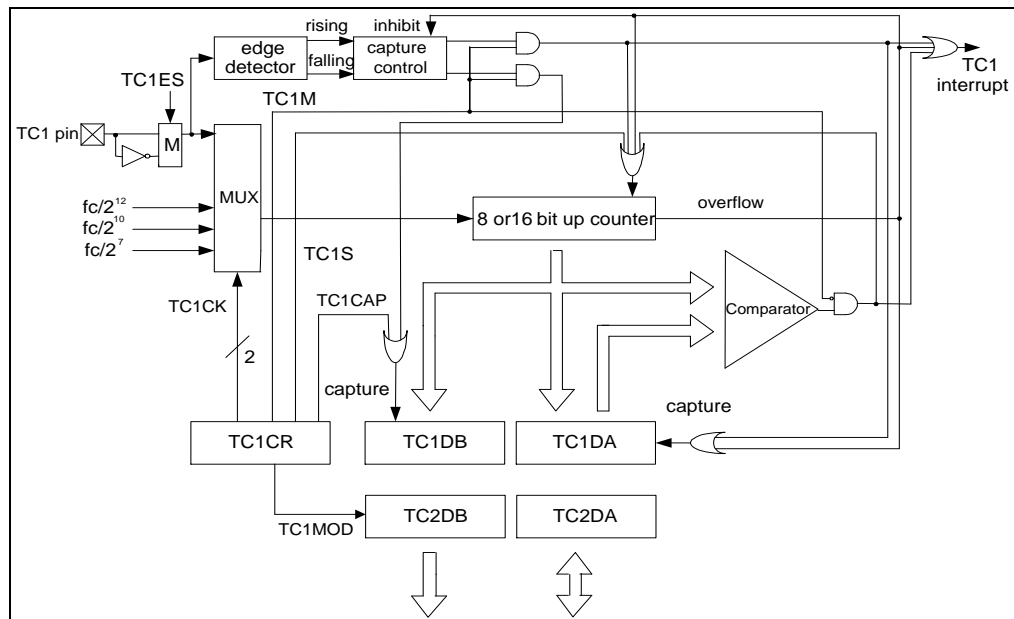

Figure 6-17 Timer / Counter 1 Configuration

**In Timer mode**, counting up is performed using an internal clock. When the contents of the up-counter matched the TC1DA, then interrupt is generated and the counter is cleared. Counting up resumes after the counter is cleared. The current contents of the up-counter are loaded into TC1DB by setting TC1CAP to “1” and the TC1CAP is automatically cleared to “0” after capture. The timer mode will operate with 16bits by setting TC1MOD to “1”

**In Counter mode**, counting up is performed using an external clock input pin (TC1) and either rising or falling edge can be selected by TC1ES but **both edges cannot be used**. When the contents of the up-counter matched the TC1DA, then interrupt is generated and the counter is cleared. Counting up resumes after the counter is cleared. The current contents of the up-counter are loaded into TC1DB by setting TC1CAP to “1” and the TC1CAP is automatically cleared to “0” after capture. The counter mode will operate with 16bits by setting TC1MOD to “1”.

**In Capture mode**, the pulse width, period and duty of the TC1 input pin are measured in this mode, which can be used to decode the remote control signal. The counter is free running by the internal clock. On the rising (falling) edge of TC1 pin input, the contents of counter is loaded into TC1DA, then the counter is cleared and interrupt is generated. On a falling (rising) edge of TC1 pin input, the contents of the counter are loaded into TC1DB. The counter is still counting, on the next rising edge of TC1 pin input, the contents of the counter are loaded into TC1DA, the counter is cleared and interrupt is generated again. If an overflow before the edge is detected, the FFH is loaded into TC1DA and the overflow interrupt is generated. During interrupt processing, it can be determined whether or not there is an overflow by checking whether or not the TC1DA value is FFH.

After an interrupt (capture to TC1DA or overflow detection) is generated, capture and overflow detection are halted until TC1DA is read out. The capture mode will operate with 16bits by setting TC1MOD to "1".

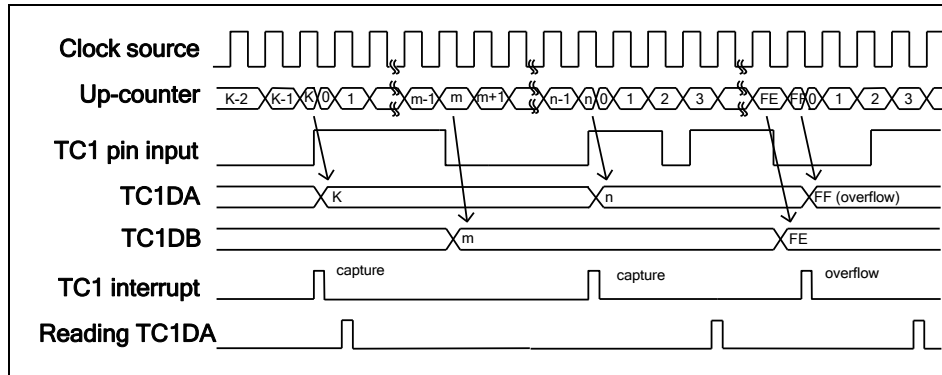

Figure 6-18 (a) Timing Chart of 8 bits Capture Mode

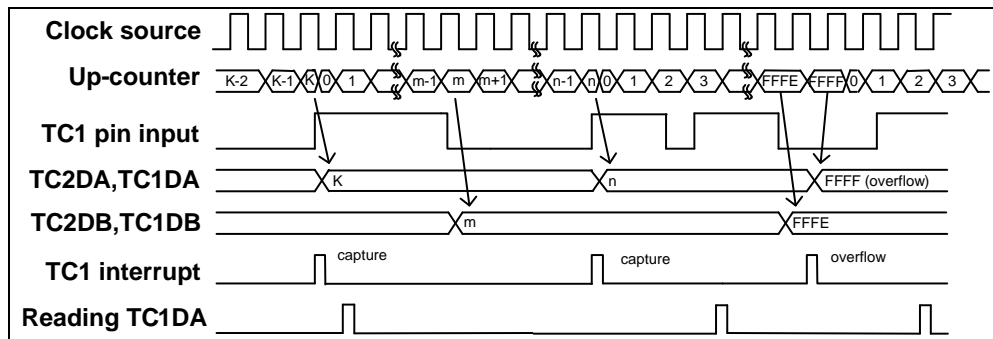

Figure 6-18 (b) Timing Chart of 16 bits Capture Mode

## 6.10 Timer/Counter 3

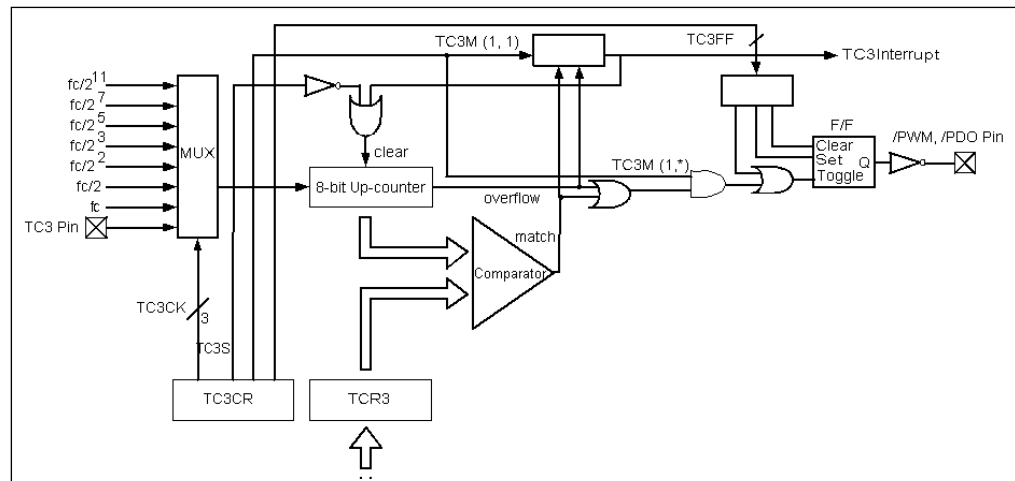

Figure 6-19 Timer/Counter 3 Mode Configuration

■ **Timer Mode**

In Timer mode, counting up is performed using the internal clock (rising edge trigger). When the contents of the up-counter matched with TCR3, interrupt is generated and the counter is cleared. Counting up resumes after the counter is cleared.

■ **Counter Mode**

In Counter mode, counting up is performed using the external clock input pin (TC3 pin). When the contents of the up-counter matched with TCR3, interrupt is then generated and the counter is cleared. Counting up resumes after the counter is cleared.

■ **Programmable Divider Output (PDO) Mode**

In Programmable Divider Output (PDO) mode, counting up is performed using the internal clock. The contents of TCR3 are compared with the contents of the up-counter. The F/F output is toggled and the counter is cleared each time a match is found. The F/F output is inverted and output to /PDO pin. This mode can generate 50% duty pulse output. **The F/F can be initialized by program and it is initialized to “0” during reset.** A TC3 interrupt is generated each time the /PDO output is toggled.

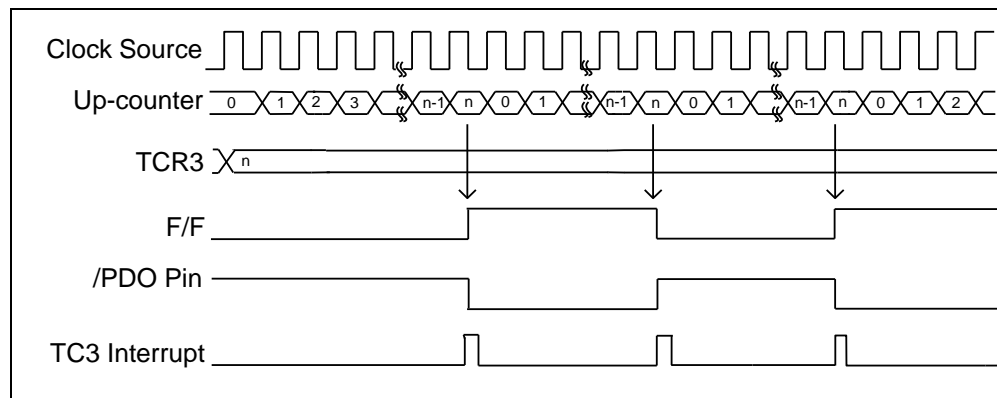

Figure 6-20 PDO Mode Timing Diagram

■ **Pulse Width Modulation (PWM) Output Mode**

In Pulse Width Modulation (PWM) Output mode, counting up is performed using the internal clock. The contents of TCR3 are compared with the contents of the up-counter. The F/F is toggled when a match is found. While the counter is counting, the F/F is toggled again when the counter overflows, then the counter is cleared. The F/F output is inverted and output to the /PWM pin. A TC3 interrupt is generated each time an overflow occurs. **TCR3 is configured as a 2-stage shift register and during output, will not switch until one output cycle is completed even if TCR3 is overwritten.** Hence, the output can be changed continuously. Also, on the first time, TRC3 is shifted by setting TC3S to “1” after data is loaded to TCR3.

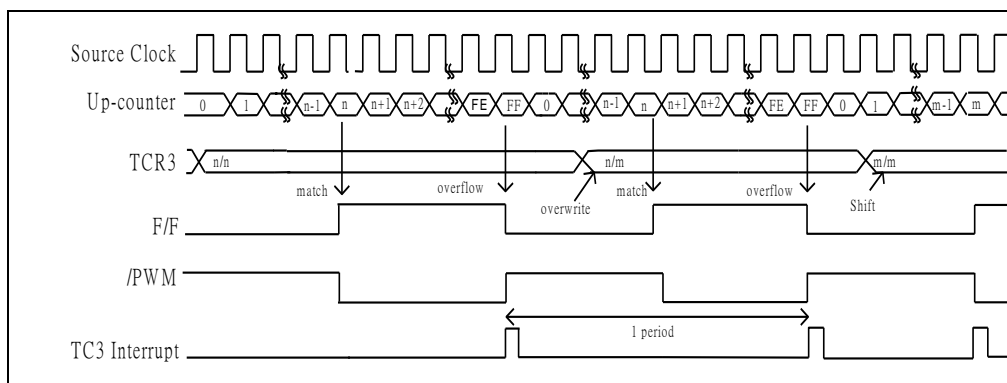

Figure 6-21 PWM Mode Timing Diagram

## 6.12 Oscillator

### 6.12.1 Oscillator Modes

The device can be operated in four different oscillator modes, such as Internal RC oscillator mode (IRC), High Crystal oscillator mode (HXT), and Low Crystal oscillator mode (LXT). You can select one of such modes by programming OSC2, OSC1, and OSC0 in the Code Option register. The following table depicts how these four modes are defined.

#### ■ Oscillator Modes defined by OSC2 ~ OSC0

Mode	OSC2	OSC1	OSC0
XT (Crystal oscillator mode) <sup>1</sup>	0	0	0
HXT1 (High Crystal 1 oscillator mode) <sup>2</sup>	0	0	1
LXT1 (Low Crystal 1 oscillator mode) <sup>3</sup>	0	1	0
Reserve	0	1	1
IRC mode, OSC0 (P54) act as I/O pin	1	0	0
IRC mode, OSC0 (P54) act as RCOU pin	1	0	1
HXT2 (High Crystal 2 oscillator mode) <sup>4</sup>	1	1	0
Reserve	1	1	1

<sup>1</sup> The Frequency range of HXT1 mode is 12 MHz ~ 6 MHz.

<sup>2</sup> The Frequency range of XT mode is 6 MHz ~ 1 MHz.

<sup>3</sup> The Frequency range of LXT1 mode is 1 MHz ~ 100kHz.

<sup>4</sup> The Frequency range of HXT2 mode is 20 MHz ~ 12 MHz.

In LXT, XT, HXT modes, OSC1 and OSC0 are implemented. They cannot be used as normal I/O pins.

In IRC mode, P55 is used as normal I/O pin. The maximum operating frequency of the crystal/resonator on the different VDD is shown below:

■ **Summary of Maximum Operating Speeds**

Conditions	VDD	Max Fxt. (MHz)
Two cycles with two clocks	2.2	4.0
	4.0	8.0
	5.0	20.0

**6.12.2 Crystal Oscillator/Ceramic Resonators (Crystal)**

The EM78F734N can be driven by an external clock signal through the OSCI pin as illustrated below.

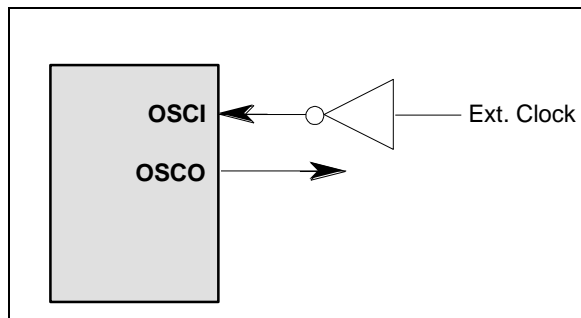

Figure 6-22 External Clock Input Circuit

In most applications, Pin OSCI and Pin OSCO can be connected with a crystal or ceramic resonator to generate oscillation as depicted in the following figure. The same thing applies to HXT mode or LXT mode.

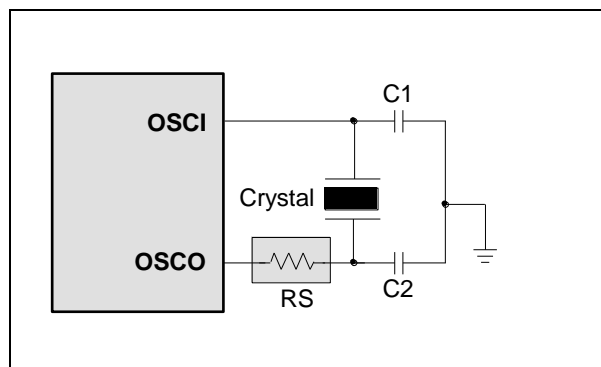

Figure 6-23 Crystal/Resonator Circuit

The following table provides the recommended values of C1 and C2. Since each resonator has its own attributes, you should refer to its specification for appropriate values of C1 and C2. A serial resistor RS, may be necessary for AT strip cut crystal or low frequency mode.

■ **Capacitor Selection Guide for Crystal Oscillator or Ceramic Resonator**

Oscillator Type	Frequency Mode	Frequency	C1(pF)	C2(pF)
Ceramic Resonators	LXT1 (100K~1 MHz)	100kHz	60pF	60pF
		200kHz	60pF	60pF
		455kHz	40pF	40pF
		1 MHz	30pF	30pF
	XT (1M~6 MHz)	1.0 MHz	30pF	30pF
		2.0 MHz	30pF	30pF
		4.0 MHz	20pF	20pF
Crystal Oscillator	LXT1 (100K~1 MHz)	100kHz	60pF	60pF
		200kHz	60pF	60pF
		455kHz	40pF	40pF
		1 MHz	30pF	30pF
	XT (1~6 MHz)	1.0 MHz	30pF	30pF
		2.0 MHz	30pF	30pF
		4.0 MHz	20pF	20pF
		6.0 MHz	30pF	30pF
	HXT1 (6~12 MHz)	6.0 MHz	30pF	30pF
		8.0 MHz	20pF	20pF
		12.0 MHz	30pF	30pF
	HXT2 (12~20 MHz)	12.0 MHz	30pF	30pF
		16.0 MHz	20pF	20pF



### 6.12.3 Internal RC Oscillator Mode

EM78F734N offers a versatile internal RC mode with default frequency value of 4 MHz. Internal RC oscillator mode has other frequencies (455kHz, 1 MHz and 8 MHz) that can be set by Code Option (Word 1), RCM1 and RCM0 when COBS =0, or set by Bank 1 R8 Bits 7, 6 when COBS=1 . All these four main frequencies can be calibrated by programming the Code Option (Word 1) bits, C6~C0. The table describes a typical instance of the calibration.

■ **Internal RC Drift Rate (Ta=25°C, VDD=5 V ± 5%, VSS=0V)**

Internal RC	Drift Rate			
	Temperature (-40°C~85°C)	Voltage (2.2V~5.5V)	Process	Total
455KHz	± 2%	± 3.5%	± 1%	± 6.5%
1 MHz	± 2%	± 3.5%	± 1%	± 6.5%
4 MHz	± 2%	± 3.5%	± 1%	± 6.5%
8 MHz	± 2%	± 3.5%	± 1%	± 6.5%

### 6.13 Code Option Register

The EM78F734N has a Code Option Word that is not part of the normal program memory. The option bits cannot be accessed during normal program execution.

Code Option Register and Customer ID Register arrangement distribution:

Word 0	Word 1	Word 2
Bit 12~Bit 0	Bit 12~Bit 0	Bit 12~Bit 0

#### 6.13.1 Code Option Register (Word 0)

Word 0													
Bit	Bit 12	Bit 11	Bit 10	Bit 9	Bit 8	Bit 7	Bit 6	Bit 5	Bit 4	Bit 3	Bit 2	Bit 1	Bit 0
Mnemonic	HLP	NRHL	NRE	RESETEN	-	-	ENWDT	OSC2	OSC1	OSC0	PR2	PR1	PR0
1	Low	8/fc	Disable	Enable	-	-	Enable	High	High	High	High	High	High
0	High	32/fc	Enable	Disable	-	-	Disable	Low	Low	Low	Low	Low	Low
default	0	0	0	0	0	0	0	1	0	0	0	0	0

**Bit 12 (HLP):** Power consumption selection. (High power consumption mode can increase the anti-noise functionality. If the operating frequency is 1 MHz or less, and it is necessary to enhance the anti-noise feature, user can select High power consumption mode. But High power consumption mode will increase the power consumption. Please refer to the ninth DC Electrical Characteristics power status section.)

**0:** High power consumption, applies to working frequency above 1MHz (default)

**1:** Low power consumption, applies to working frequency at 1MHz or below 1MHz

**Bit 11 (NRHL):** Noise rejection high/low pulse define bit. INT pin is falling edge trigger.

**1 :** Pulses equal to  $8/f_c$  [s] is regarded as signal

**0 :** Pulses equal to  $32/f_c$  [s] is regarded as signal (default)

**Bit 10 (NRE):** Noise rejection enable. INT pin is falling edge trigger.

**1:** Disable noise rejection

**0:** Enable noise rejection (default)

**Bit 9 (RESETEN):** Reset Pin Enable Bit

**1 :** Enable, P83//RESET → RESET pin.

**0 :** Disable, P83//RESET → P83 (default)

**Bits 8 ~ 7:** Not used, always set to “0”

**Bit 6 (ENWDT):** Watchdog timer enable bit

**1 :** Enable

**0 :** Disable

**Bits 5 ~ 3 (OSC2 ~ OSC0):** Oscillator Mode Selection bits

Mode	OSC2	OSC1	OSC0
XT (Crystal oscillator mode) <sup>1</sup>	0	0	0
HXT1 (High Crystal 1 oscillator mode) <sup>2</sup>	0	0	1
LXT1 (Low Crystal 1 oscillator mode) <sup>3</sup>	0	1	0
Reserve	0	1	1
IRC mode, OSC0 (P54) act as I/O pin	1	0	0
IRC mode, OSC0 (P54) act as RCOU pin	1	0	1
HXT2 (High Crystal 2 oscillator mode) <sup>4</sup>	1	1	0
Reserve	1	1	1

<sup>1</sup> The Frequency range of HXT1 mode is 12 MHz ~ 6 MHz.

<sup>2</sup> The Frequency range of XT mode is 6 MHz ~ 1 MHz.

<sup>3</sup> The Frequency range of LXT1 mode is 1 MHz ~ 100kHz.

<sup>4</sup> The Frequency range of HXT2 mode is 20 MHz ~ 12 MHz.

**Bits 2 ~ 0 (PR2 ~ PR0):** Protect Bit. PR2~PR0 are protect bits, protect type is as follows:

PR2	PR1	PR0	Protect
1	1	1	Enable
0	0	0	Disable

### 6.13.2 Code Option Register (Word 1)

Word 1													
Bit	Bit 12	Bit 11	Bit 10	Bit 9	Bit 8	Bit 7	Bit 6	Bit 5	Bit 4	Bit 3	Bit 2	Bit 1	Bit 0
Mnemonic	COBS	TCEN	C6	C5	C4	C3	C2	C1	C0	RCM1	RCM0	LVR1	LVR0
1	High	TCC	High	High	High	High	High	High	High	High	High	High	High
0	Low	P77	Low	Low	Low	Low	Low	Low	Low	Low	Low	Low	Low
default	0	0	0	0	0	0	0	0	0	0	0	0	0

**Bit 12 (COBS):** Code Option Bit Selection

**0 :** IRC frequency select for code option (default)

**1 :** IRC frequency select internal register by Bank 1 R8(7,6)

**Bit 11 (TCEN):** TCC enable bit

**0 :** P77/TCC is set as P77

**1 :** P77/TCC is set as TCC

**Bits 10 ~ 4 (C6 ~ C0):** Internal RC mode calibration bits. (IRC frequency auto calibration)

**Bits 3 ~ 2 (RCM1 ~ RCM0):** RC mode selection bits

RCM 1	RCM 0	*Frequency (MHz)
0	0	4
0	1	1
1	0	8
1	1	455k

**Bits 1 ~ 0 (LVR1 ~ LVR0):** Low voltage reset enable bits

LVR1	LVR0	Reset Level	Release Level
0	0	NA	NA
0	1	2.5V	2.6V
1	0	2.9V	3.0V
1	1	3.2V	3.3V

**Note:** LVR1, LVR0="0, 0": LVR disabled, power-on reset point of EM78F734N is 2.4V.

LVR1, LVR0="0, 1": If Vdd < 2.9V, the EM78F734N will reset.

LVR1, LVR0="1, 0": If Vdd < 3.2V, the EM78F734N will reset.

LVR1, LVR0="1, 1": If Vdd < 3.9V, the EM78F734N will reset.

### 6.13.3 Code Option Register (Word 2)

Word 2													
Bit	Bit 12	Bit 11	Bit 10	Bit 9	Bit 8	Bit 7	Bit 6	Bit 5	Bit 4	Bit 3	Bit 2	Bit 1	Bit 0
Mnemonic	SC4	SC3	SC2	SC1	SC0	EFTIM	-	-	SFS	IRE	-	-	-
1	High	High	High	High	High	20MHz	-	-	128kHz	Enable	-	-	-
0	Low	Low	Low	Low	Low	10MHz	-	-	16kHz	Disable	-	-	-
Default	0	0	0	0	0	1	0	0	0	0	0	0	0

**Bits 12 ~ 8 (SC4 ~ SC0):** Calibrator of sub frequency (WDT frequency auto calibration)

**Bit 7 (EFTIM):** EFT improvement. If the MCU is at VDD=5V with working frequency of <12 MHz, or at VDD=3V with working frequency of <6 MHz, enabling this function can improve the performance of the electrical fast transient (EFT) test. If the MCU is at VDD=5V and the working frequency is >12 MHz, choose EFTIM=1

**0:** 10 MHz

**1:** 20 MHz

**Bits 6 ~ 5:** Not used, always set to "0"

**Bits 4 (SFS):** Sub-frequency select.

**0:** 16kHz (WDT frequency)

**1:** 128kHz

**Bit 3 (IRE):** IRC Regulator Enable bit

**0:** Disable regulator for saving power but more error of IRC.

**1:** Enable regulator for improving IRC accurately but more power consumed.

**Bits 2 ~ 0:** Not used, always set to "0"

## 6.14 Power-on Considerations

Any microcontroller is not guaranteed to start to operate properly before the power supply stays has stabilized. The EM78F734N has an on-chip Power-on Voltage Detector (POVD) with a detecting level of 2.0V. It will work well if Vdd can rise quickly enough (50ms or less). In many critical applications, however, extra devices are still required to assist in solving power-up problems.

## 6.15 External Power-on Reset Circuit

The circuit shown in Figure 6-24 uses an external RC to generate a reset pulse. The pulse width (time constant) should be kept long enough for Vdd to reached minimum operation voltage. This circuit is used when the power supply has slow rise time. Because the current leakage from the /RESET pin is  $\pm 5\mu\text{A}$ , it is recommended that R should not be greater than 40K. In this way, the /RESET pin voltage is held below 0.2V. The diode (D) functions as a short circuit at the moment of power down.

The capacitor C will discharge rapidly and fully. Rin, the current-limited resistor, will prevent high current or ESD (electrostatic discharge) from flowing to pin /RESET.

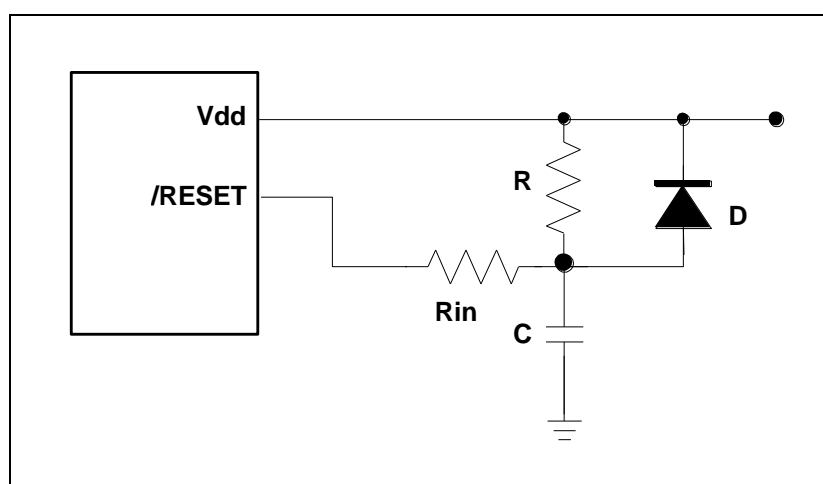

Figure 6-24 External Power-up Reset Circuit

## 6.16 Residue-Voltage Protection

When battery is replaced, device power (Vdd) is taken off but residue-voltage remains. The residue-voltage may trip below Vdd minimum, but not to zero. This condition may cause a poor power-on reset. Figure 6-25 and Figure 6-26 show how to build a residue-voltage protection circuits.

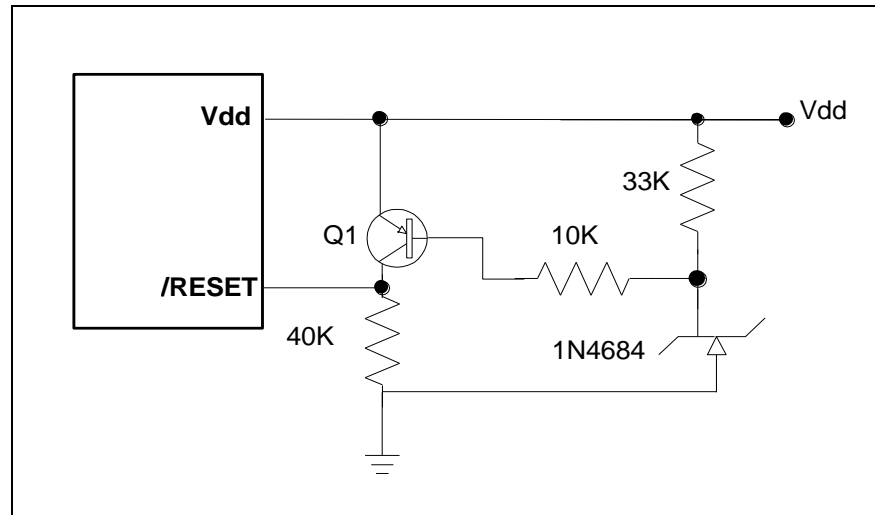

Figure 6-25 Circuit 1 for the Residue Voltage Protection

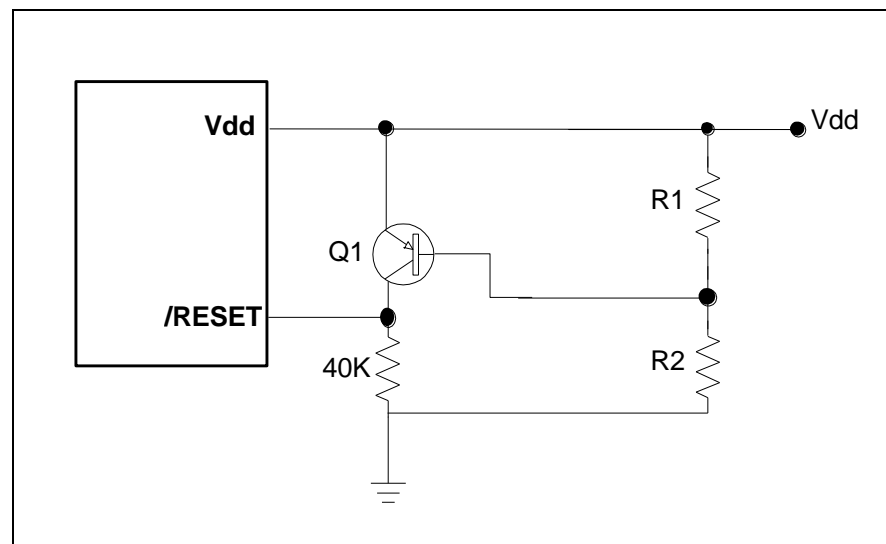

Figure 6-26 Circuit 2 for the Residue Voltage Protection

## 6.17 Instruction Set

Each instruction in the instruction set is a 13-bit word divided into an OP code and one or more operands. Normally, all instructions are executed within one single instruction cycle (one instruction consists of two oscillator periods), unless the program counter is changed by instruction "MO" R,A, "AD" R2,A, or by instructions of arithmetic or logic operation on R2 "e.g. "SU" R,A, "BS(C" R,6", "LR R2", ....). In this case, the execution takes two instruction cycles.

(300) If for some reasons, the specification of the instruction cycle is not suitable for certain applications, try modifying the instruction as follows: "MP", "CLL", "ET", "RTL", "RETI" commands are executed with one instruction cycle, the conditional "kip" ("BS", "BC", "JZ", "ZA", "JZ", "DJZA") commands which were tested to be true, are executed within two instruction cycles. The instructions that are written to the program counter also take two instruction cycles.

In addition, the instruction set has the following features:

- (1) Every bit of any register can be set, cleared, or tested directly.
- (2) The I/O register can be regarded as general register. That is, the same instruction can operate on the I/O register.

**■ Instruction Set Table:**

The following symbols are used in the following table:

“**R**” Register designator that specifies which one of the registers (including operation and general purpose registers) is to be utilized by the instruction.

“**b**” Bit field designator that selects the value for the bit located in the register R and which affects the operation.

“**K**” 8 or 10-bit constant or literal value

Mnemonic	Operation	Status Affected
NOP	No Operation	None
DAA	Decimal Adjust A	C
CONTW	A → CONT	None
SLEP	0 → WDT, Stop oscillator	T, P
WDTC	0 → WDT	T, P
IOW R	A → IOCR	None <sup>1</sup>
ENI	Enable Interrupt	None
DISI	Disable Interrupt	None
RET	[Top of Stack] → PC	None
RETI	[Top of Stack] → PC, Enable Interrupt	None
CONTR	CONT → A	None
IOR R	IOCR → A	None <sup>1</sup>
MOV R,A	A → R	None
CLRA	0 → A	Z
CLR R	0 → R	Z
SUB A,R	R-A → A	Z, C, DC
SUB R,A	R-A → R	Z, C, DC
DECA R	R-1 → A	Z
DEC R	R-1 → R	Z
OR A,R	A ∨ R → A	Z
OR R,A	A ∨ R → R	Z
AND A,R	A & R → A	Z
AND R,A	A & R → R	Z
XOR A,R	A ⊕ R → A	Z
XOR R,A	A ⊕ R → R	Z
ADD A,R	A + R → A	Z, C, DC
ADD R,A	A + R → R	Z, C, DC
MOV A,R	R → A	Z
MOV R,R	R → R	Z
COMA R	/R → A	Z
COM R	/R → R	Z
INCA R	R+1 → A	Z
INC R	R+1 → R	Z

<sup>1</sup> This instruction is applicable to IOC5~IOC7, IOCA ~ IOCF only.

Mnemonic	Operation	Status Affected
DJZA R	R-1 → A, skip if zero	None
DJZ R	R-1 → R, skip if zero	None
RRCA R	R(n) → A(n-1), R(0) → C, C → A(7)	C
RRC R	R(n) → R(n-1), R(0) → C, C → R(7)	C
RLCA R	R(n) → A(n+1), R(7) → C, C → A(0)	C
RLC R	R(n) → R(n+1), R(7) → C, C → R(0)	C
SWAPA R	R(0-3) → A(4-7), R(4-7) → A(0-3)	None
SWAP R	R(0-3) ↔ R(4-7)	None
JZA R	R+1 → A, skip if zero	None
JZ R	R+1 → R, skip if zero	None
BC R,b	0 → R(b)	None <sup>2</sup>
BS R,b	1 → R(b)	None <sup>3</sup>
JBC R,b	if R(b)=0, skip	None
JBS R,b	if R(b)=1, skip	None
CALL k	PC+1 → [SP], (Page, k) → PC	None
JMP k	(Page, k) → PC	None
MOV A,k	k → A	None
OR A,k	A ∨ k → A	Z
AND A,k	A & k → A	Z
XOR A,k	A ⊕ k → A	Z
RETL k	k → A, [Top of Stack] → PC	None
SUB A,k	k-A → A	Z, C, DC
ADD A,k	k+A → A	Z, C, DC
BANK k	K → R4(7:6)	None
LCALL k	Next instruction : k kkkk kkkk kkkk PC+1 → [SP], k → PC4	None
LJMP k	Next instruction : k kkkk kkkk kkkk k → PC4	None
TBRD R	If Bank 3 R6.7=0, machine code (7:0) → R Else machine code (12:8) → R(4:0), R(7:5)=(0,0,0)	None

<sup>2</sup> This instruction is not recommended for interrupt status register operation.

<sup>3</sup> This instruction cannot operate under interrupt status register.

## 7 Timing Diagrams

### AC Test Input/Output Waveform

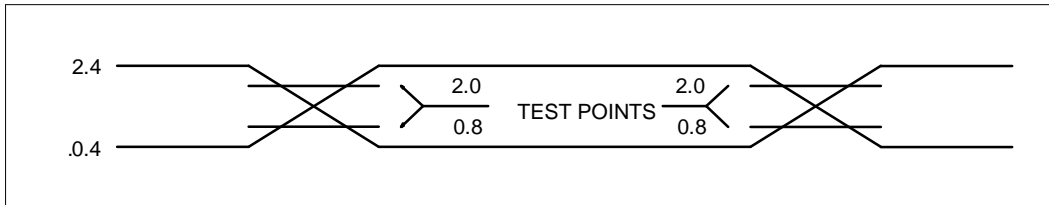

AC Testing: Input are driven at 2.4V for logic "1" and 0.4V for logic "0".

Timing measurements are made at 2.0V for logic "1", and 0.8V for logic "0".

Figure 7-1 AC Test Timing Diagram

### Reset Timing (CLK="0")

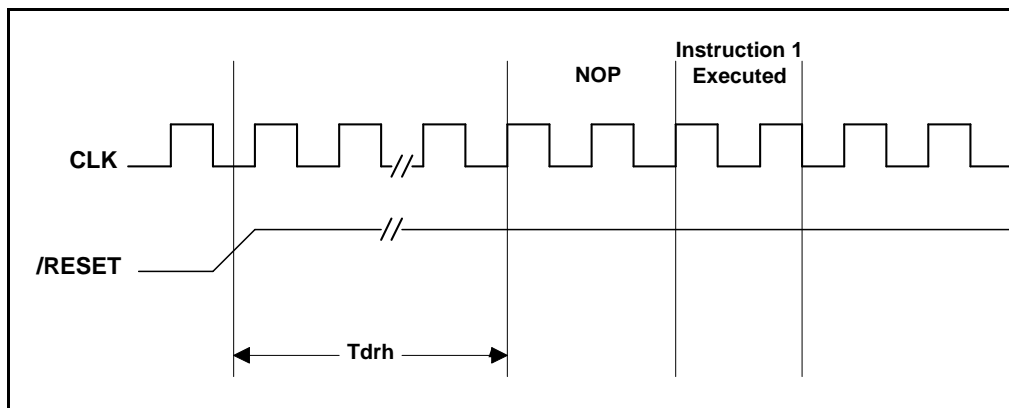

Figure 7-2 Reset Timing Diagram

### TCC Input Timing (CLKS="0")

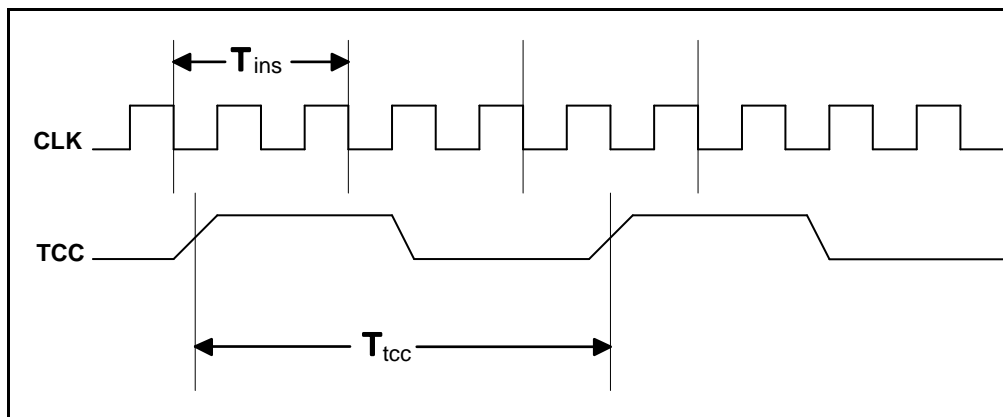

Figure 7-3 TCC Input Timing Diagram

## 8 Absolute Maximum Ratings

### ■ EM78F734N

Items	Rating		
Temperature under bias	-40°C	to	85°C
Storage temperature	-65°C	to	150°C
Working voltage	2.2	to	5.5V
Working frequency	DC	to	20 MHz*
Input voltage	Vss-0.3V	to	Vdd+0.5V
Output voltage	Vss-0.3V	to	Vdd+0.5V

**Note:** \* These parameters are theoretical values and have not been tested.

## 9 DC Electrical Characteristics

VDD=5.0V, VSS=0V, Ta=25°C

Symbol	Parameter	Condition	Min.	Typ.	Max.	Unit
Fxt	Crystal: VDD to 3V	Two cycles with two clocks	DC	-	4	MHz
	Crystal: VDD to 5V		DC	-	20	MHz
	IRC: VDD to 5 V	4 MHz, 455kHz, 1 MHz, 8 MHz	F±30%	F	F±30%	Hz
IIL	Input Leakage Current for input pins	VIN = VDD, VSS	-	-	±1	μA
VIHRC	Input High Threshold Voltage (Schmitt Trigger)	OSCI in RC mode	3.9	4	4.1	V
VILRC	Input Low Threshold Voltage (Schmitt Trigger)	OSCI in RC mode	1.7	1.8	1.9	V
IIL	Input Leakage Current for input pins	VIN = VDD, VSS	-1	0	1	μA
VIH1	Input High Voltage (Schmitt trigger)	Ports 5, 6, 7, 8	-	0.7VDD (2.8V)	-	V
VIL1	Input Low Voltage (Schmitt trigger)	Ports 5, 6, 7, 8	-	0.3VDD (2.2V)	-	V
VIHT1	Input High Threshold Voltage (Schmitt Trigger)	/RESET	-	0.7VDD	-	V
VILT1	Input Low Threshold Voltage (Schmitt trigger)	/RESET	-	0.3VDD	-	V
VIHT2	Input High Threshold Voltage (Schmitt Trigger)	TCC, INT	-	0.7VDD	-	V
VILT2	Input Low Threshold Voltage (Schmitt Trigger)	TCC, INT	-	0.3VDD	-	V
VIHX1	Clock Input High Voltage	OSCI in crystal mode	2.9	3.0	3.1	V
VILX1	Clock Input Low Voltage	OSCI in crystal mode	1.7	1.8	1.9	V

**Note:** \* The parameters are theoretical and have not been tested or verified.

\* Data in the Minimum, Typical, Maximum ("Min.", "Typ.", "Max.") column are based on hypothetical results at 25°C. These data are for design guidance only.

(Continuation)

Symbol	Parameter	Condition	Min.	Typ.	Max.	Unit
IOH1	High Drive Current (Ports 5, 6, 7, 8)	VOH = 0.9VDD	-2.5	-	-	mA
IOL1	Low Sink Current (Ports 5, 6, 7, 8)	VOL = 0.1VDD	10	-	-	mA
IPH	Pull-high current	Pull-high active, input pin at VSS	-	-	-95	μA
IPL	Pull-low current	Pull-low active, input pin at Vdd	-	-	40	μA
LVR1	Low voltage reset level 1 (2.6V)	Ta = 25°C	2.13	2.6	3.07	V
		Ta = -40°C ~ 85°C	1.72	2.6	3.46	V
LVR2	Low voltage reset level 1 (3.0V)	Ta = 25°C	2.48	3.0	3.51	V
		Ta = -40°C ~ 85°C	2.05	3.0	3.93	V
LVR3	Low voltage reset level 1 (3.3V)	Ta = 25°C	2.72	3.3	3.86	V
		Ta = -40°C ~ 85°C	2.25	3.3	4.3	V
ISB1	Power down current	All input and I/O pins at VDD, output pin floating, WDT disabled	-	-	2	μA
ISB2	Power down current	All input and I/O pins at VDD, output pin floating, WDT enabled	-	-	5	μA
ICC1	Operating supply current at two clocks	/R'SET='High', Fosc=455kHz (IRC type), Voltage = 3V, output pin floating, WDT enabled, HLP='High'	-	96	-	μA
ICC5	Operating supply current at two clocks	/RESET= 'High', Fosc=455kHz (IRC type), Voltage = 3V, output pin floating, WDT enabled, HLP='Low'	-	84.5	-	μA
ICC2	Operating supply current at two clocks	/R'SET='High', Fosc=1MHz (IRC type), Voltage = 3V, output pin floating, WDT enabled, HLP='High'	-	170	-	μA
ICC6	Operating supply current at two clocks	/RESET= 'High', Fosc=1 MHz (IRC type), Voltage = 3V, output pin floating, WDT enabled, HLP='Low'	-	160	-	μA
ICC3	Operating supply current at two clocks	/R'SET='High', Fosc=4 MHz (Crystal type), output pin floating, WDT enabled	-	1.3	-	mA
ICC4	Operating supply current at two clocks	/R'SET='High', Fosc=10 MHz (Crystal type), output pin floating, WDT enabled	-	3.25	-	mA

**NOTE**

- The above parameters are theoretical values only and have not been tested or verified.
- Data under the “**Min.**”, “**Typ.**”, and “**Max.**” (Minimum, Typical, and Maximum) columns are based on hypothetical results at 25°C. These data are for design reference only.

## 9.1 Data EEPROM Electrical Characteristics

Symbol	Parameter	Condition	Min.	Typ.	Max.	Unit
Tprog	Erase/Write cycle time	Vdd = 2.2V~ 5.5V Temperature = -40°C ~ 85°C	-	-	-	ms
Treten	Data Retention		-	10	-	Years
Tendu	Endurance time		-	100K	-	Cycles

## 9.2 Program Flash Memory Electrical Characteristics

Symbol	Parameter	Condition	Min.	Typ.	Max.	Unit
Tprog	Erase/Write cycle time	Vdd = 5.0V Temperature = -40°C ~ 85°C	-	-	-	ms
Treten	Data Retention		-	10	-	Years
Tendu	Endurance time		-	100K	-	Cycles

### 9.3 A/D Converter Characteristics

VDD=5.0V, VSS=0V, Ta=25°C

Parameter	Symbol	Test Conditions	Type			Unit
			Min.	Typ.	Max.	
Operating Range	Vdd	For 5.5v Fs=100KHz, Fin=2KHz, For 2.2v Fs=50KHz, Fin=1KHz	2.2	-	5.5	V
	VREFT		2.2	-	Vdd	V
Current Consumption	Ivdd	VREFT= Vdd=5.5v, Fs=100KHz, Fin=2KHz	-	-	0.5	mA
	Iref		-	-	50	uA
Standby Current	Isb		-	-	0.1	uA
ZAI	ZAI		-	-	10k	ohm
SNR	SNR	VREFT= Vdd=3.3v, Fs=100kHz, Fin=2kHz	70	-	-	dBc
THD	THD	VREFT= Vdd=3.3v, Fs=100kHz, Fin=2kHz	-	-	-70	dBc
SNDR	SNDR	VREFT= Vdd=3.3v, Fs=100kHz, Fin=2kHz	68	-	-	dBc
Worst Harmonic	WH	VREFT= Vdd=3.3v, Fs=100kHz, Fin=2kHz	-	-	-73	dBc
SFDR	SFDR	VREFT= Vdd=3.3V, Fs=100kHz, Fin=2kHz	73	-	-	dBc
Offset Error	OE	VREFT= Vdd=3.3V, Fs=100kHz	-	-	+/-4	LSB
Gain Error	GE	VREFT= Vdd=3.3V, Fs=100kHz	-	-	+/-8	LSB
DNL	DNL	VREFT= Vdd=3.3V, Fs=100kHz, Fin=2kHz	-	-	+/-1	LSB
INL	INL	VREFT= Vdd=3.3V, Fs=100kHz, Fin=2kHz	-	-	+/-4	LSB
Conversion Rate	Fs1	Vdd=2.7~5.5V, Fin=2kHz	100	-	-	K SPS
	Fs2	Vdd=2.2~2.7V, Fin=1kHz	50	-	-	K SPS
Power Supply Rejection Ratio	PSRR	VREFT=2.2V, SVREF="0"or"1", Vdd=2.2V ~ 5.5V, Fs=50kHz, Vin=0V ~ 2.2V	-	-	2	LSB

- Note:** <sup>1</sup> These parameters are hypothetical (not tested) and are provided for design reference only.  
<sup>2</sup> There is no current consumption when ADC is off other than minor leakage current.  
<sup>3</sup> The A/D conversion result will not decrease with an increase in the input voltage, and has no missing code.  
<sup>4</sup> These parameters are subject to change without prior notice.

## 10 AC Electrical Characteristics

EM78F734N,  $0 \leq T_a \leq 70^\circ\text{C}$ , VDD=5V, VSS=0V

$-40 \leq T_a \leq 85^\circ\text{C}$ , VDD=5V, VSS=0V

Symbol	Parameter	Conditions	Min.	Typ.	Max.	Unit
Dclk	Input CLK duty cycle	–	45	50	55	%
Tins	Instruction cycle time "C"KS="0")	Crystal type	100	–	DC	ns
		RC type	500	–	DC	ns
Ttcc	TCC input period	–	$(T_{ins}+20)/N^*$	–	–	ns
Tdrh	Device reset hold time	–	11.8	16.8	21.8	ms
Trst	/RESET pulse width	$T_a = 25^\circ\text{C}$	2000	–	–	ns
Twdt	Watchdog timer period	$T_a = 25^\circ\text{C}$	11.8	16.8	21.8	ms
Tset	Input pin setup time	–	–	0	–	ns
Thold	Input pin hold time	–	–	20	–	ns
Tdelay	Output pin delay time	Cload=20pF	–	50	–	ns

**Note:** These parameters are theoretical values and have not been tested. Such parameters are for design reference only.

Data in the Minimum, Typical, Maximum ("Min.", "Typ.", "Max.") columns are based on characterization results at  $25^\circ\text{C}$ .

\* N = selected prescaler ratio

## APPENDIX

### A Ordering and Manufacturing Information

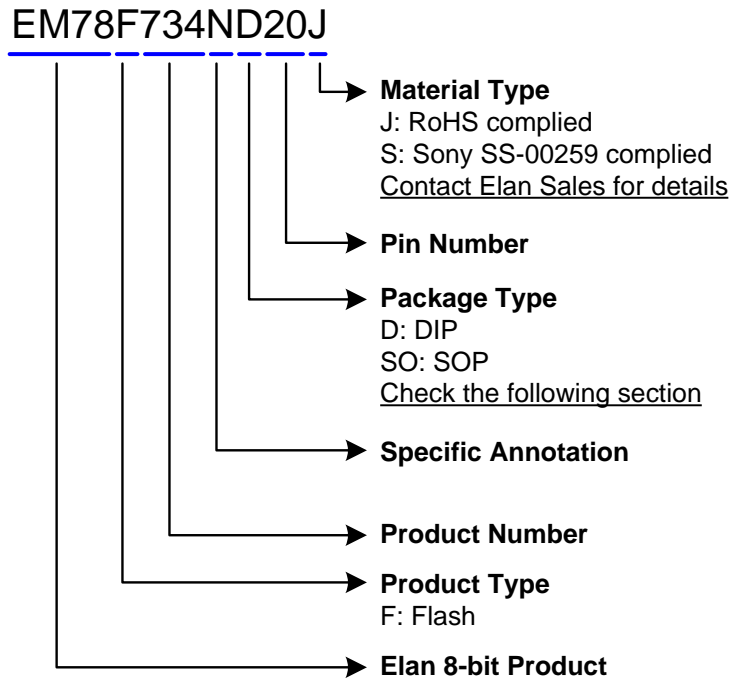

For example:

**EM78F734NSO20S**

is EM78F734N with Flash program memory, product,  
in 20-pin SOP 300mil package with Sony SS-00259 complied

### IC Mark

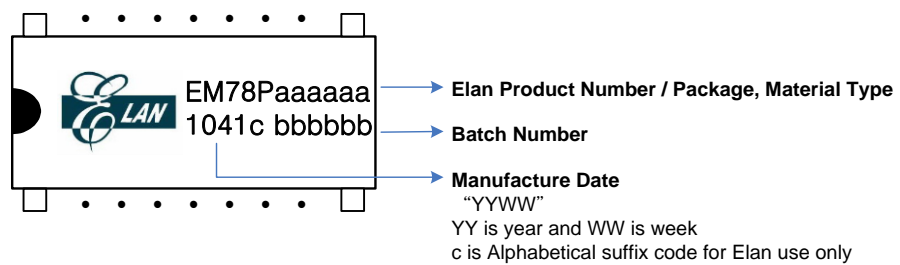

## Ordering Code

EM78F734ND20J

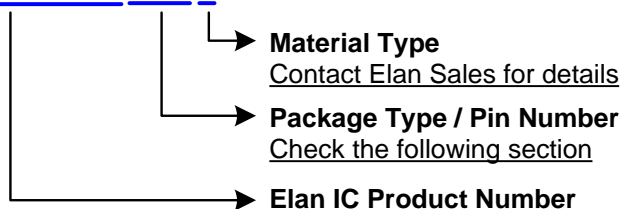

## B Package Type

Flash MCU	Package Type	Pin Count	Package Size
EM78F734ND20	PDIP	20	300 mil
EM78F734NSO20	SOP	20	300 mil
EM78F734ND18	PDIP	18	300 mil
EM78F734NSO18	SOP	18	300 mil
EM78F734ND16	PDIP	16	300 mil
EM78F734NSO16	SOP	16	300 mil
EM78F734NSO16A	SOP	16	150 mil
EM78F734NSS16	SSOP	16	150 mil

These are Green products which do not contain hazardous substances and comply with the third edition of Sony SS-00259 standard.

Pb contents should be less than 100ppm and complies with Sony specifications.

Part No.	EM78F734NS/J
Electroplate type	Pure Tin
Ingredient (%)	Sn:100%
Melting point (°C)	232°C
Electrical resistivity ( $\mu\Omega$ cm)	11.4
Hardness (hv)	8~10
Elongation (%)	>50%

## C Package Information

### C.1 EM78F734ND16 300mil

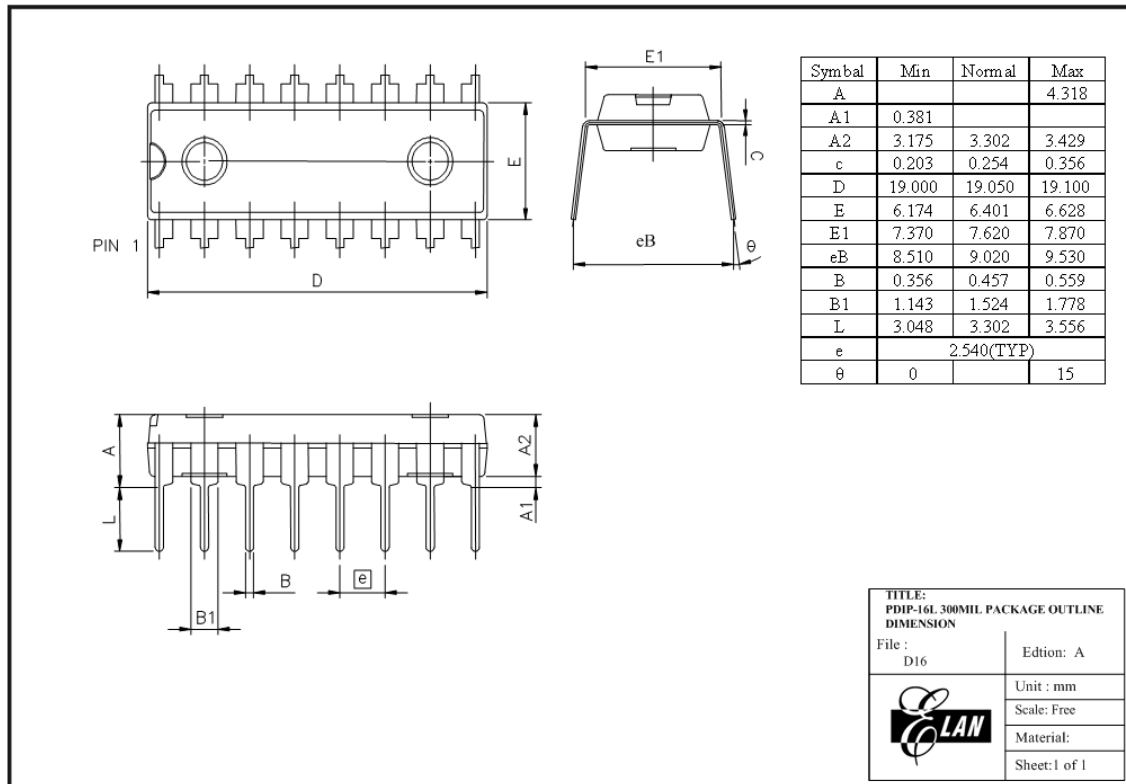

Figure B-1 EM78F734N 16-Pin PDIP Package Type

**C.2 EM78F734NSO16 300mil**

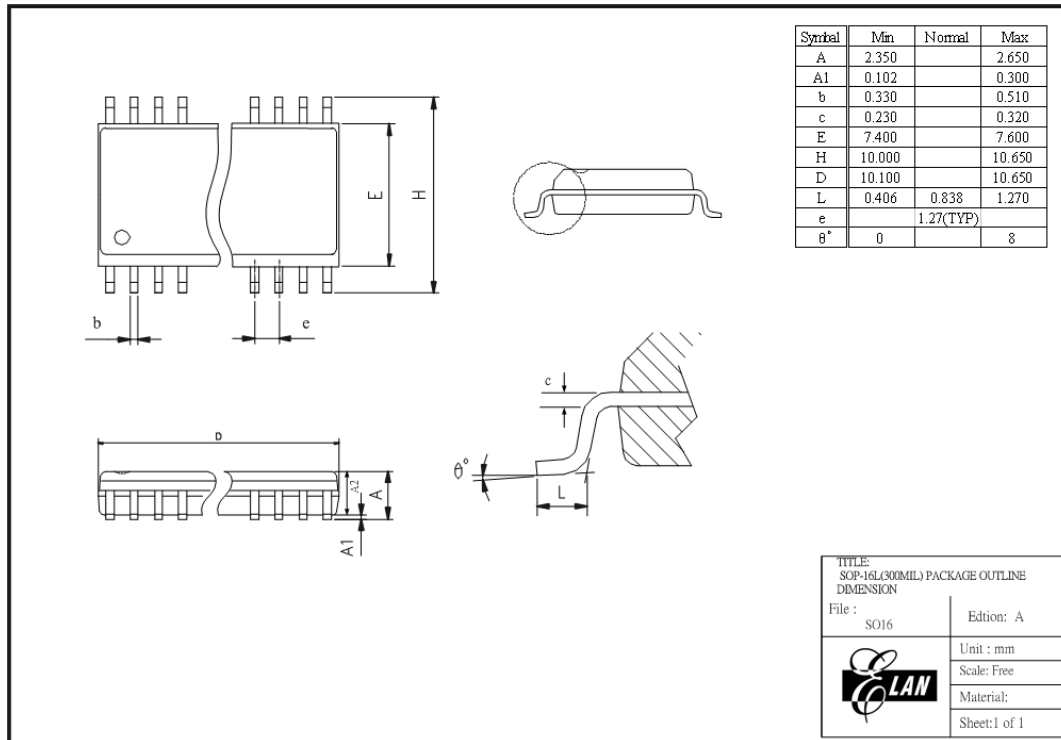

Figure B-2 EM78F734N 16-Pin SOP Package Type

### C.3 EM78F734NSO16A 150mil

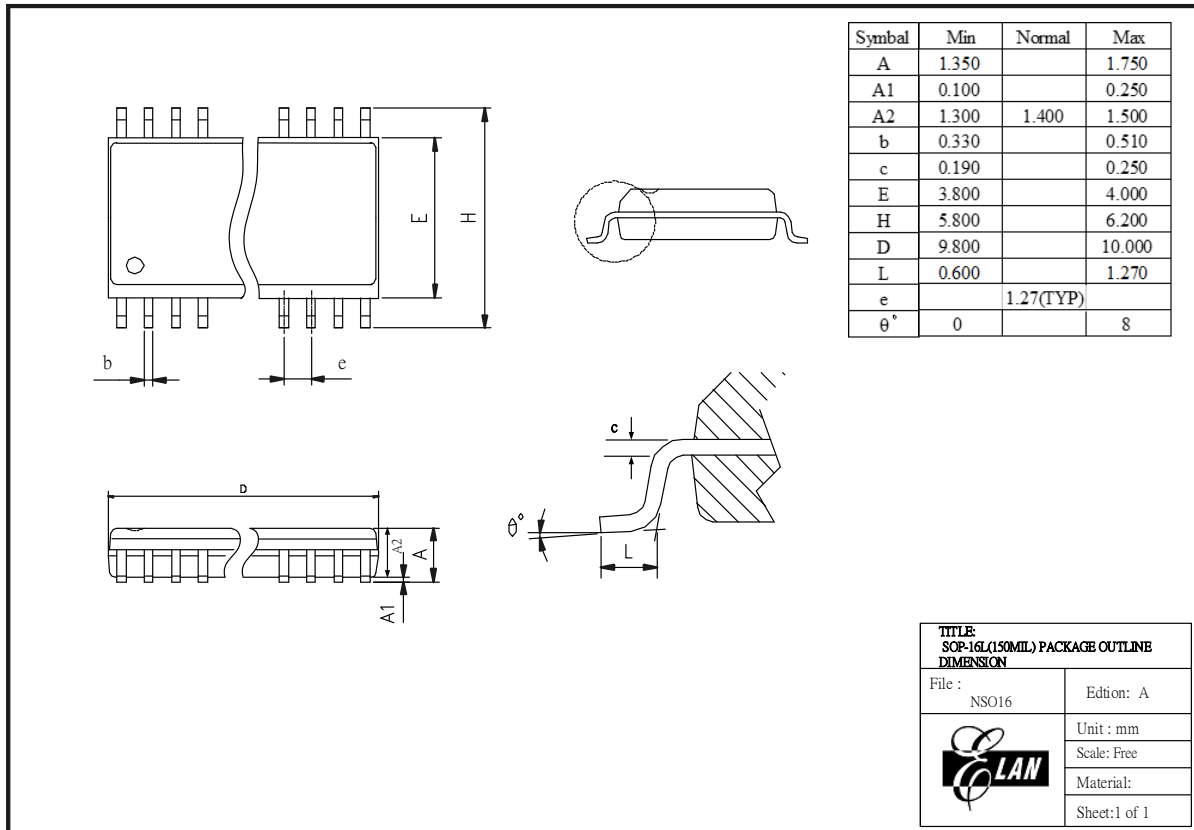

Figure B-3 EM78F734N 16-Pin SOP Package Type

### C.4 EM78F734NSS16 150mil

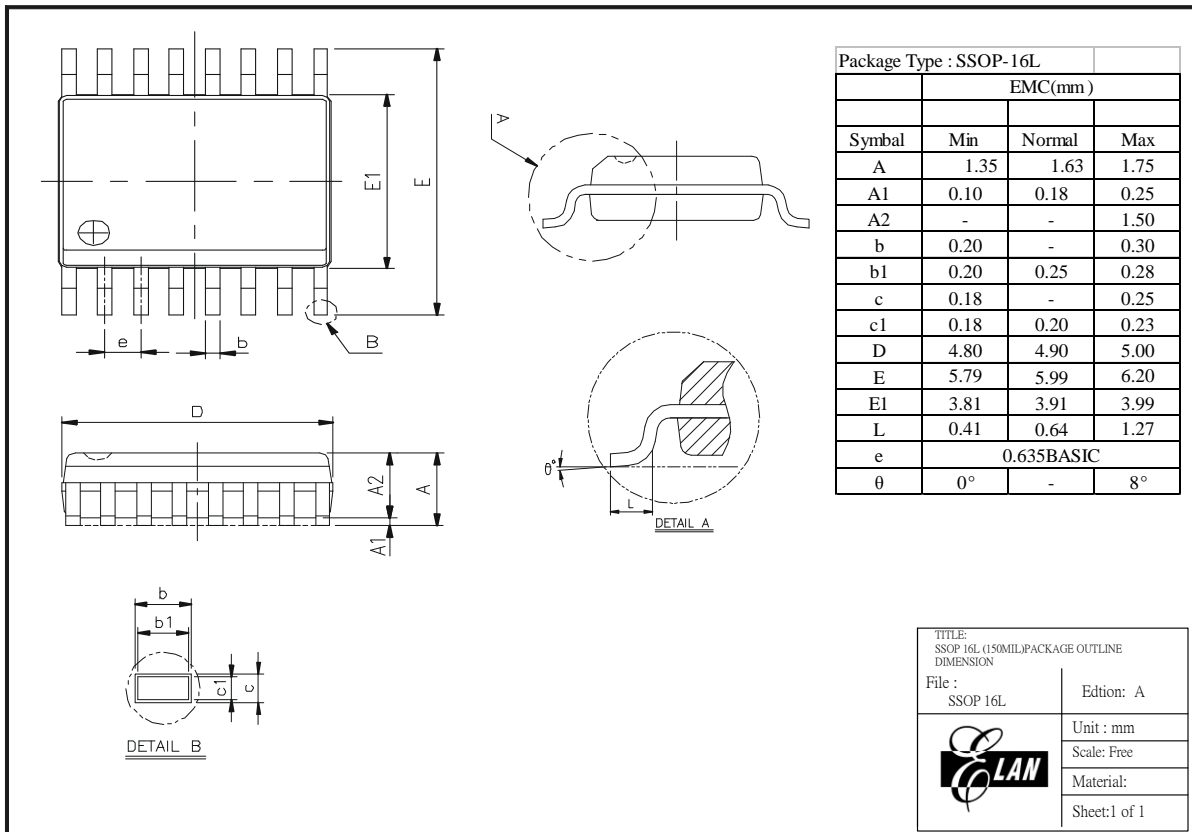

Figure B-4 EM78F734N 16-Pin SSOP Package Type

### C.5 EM78F734ND18 300mil

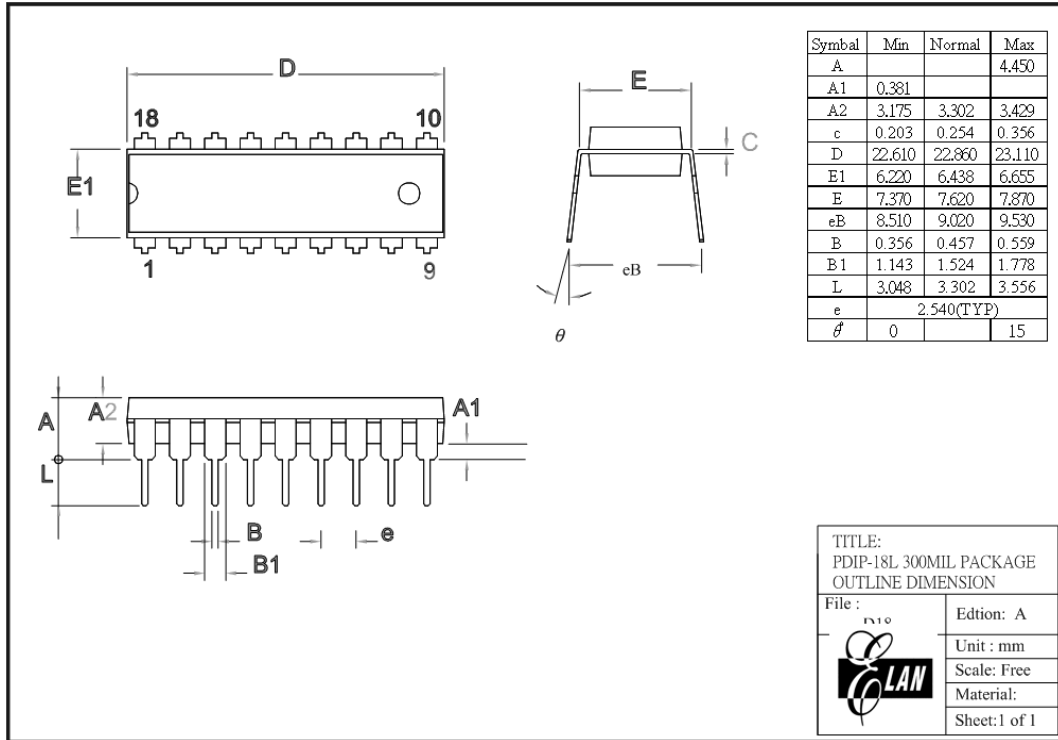

Figure B-5 EM78F734N 18-Pin PDIP Package Type

**C.6 EM78F734NSO18 300mil**

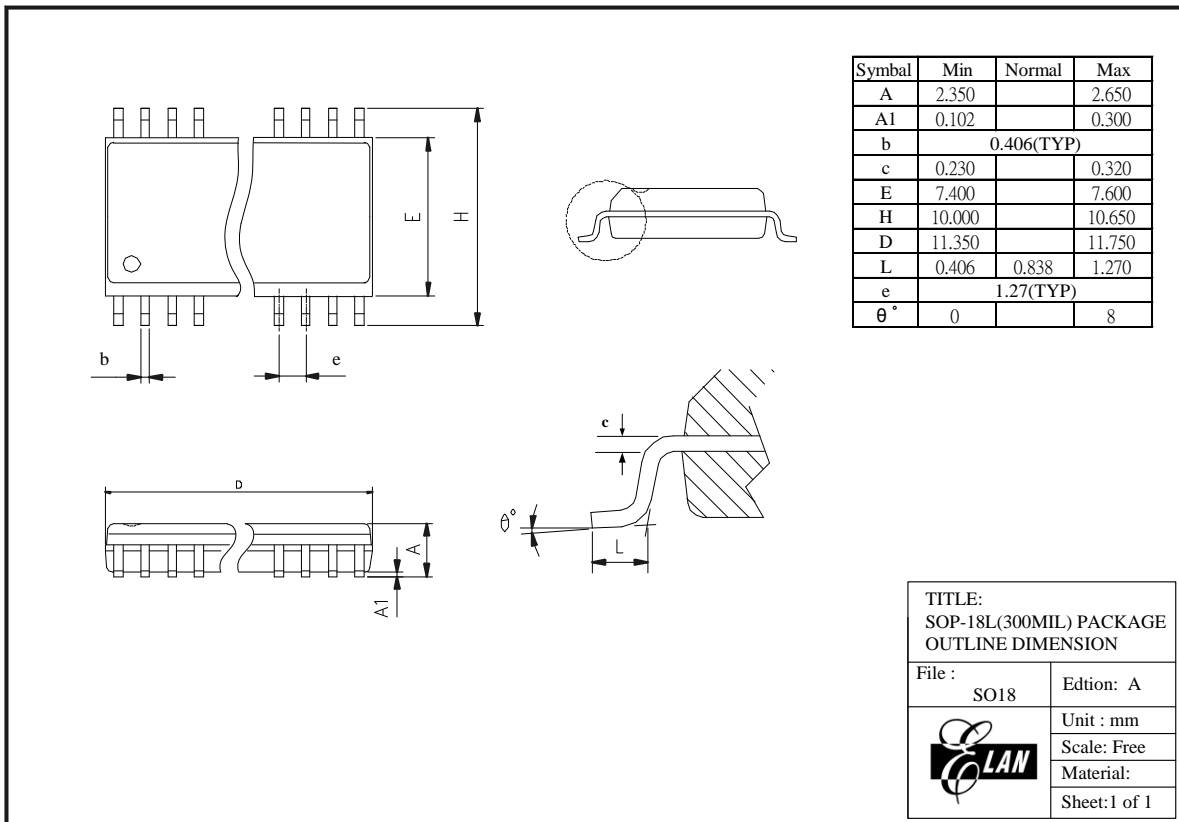

Figure B-6 EM78F734N 18-Pin SOP Package Type

### C.7 EM78F734ND20 300mil

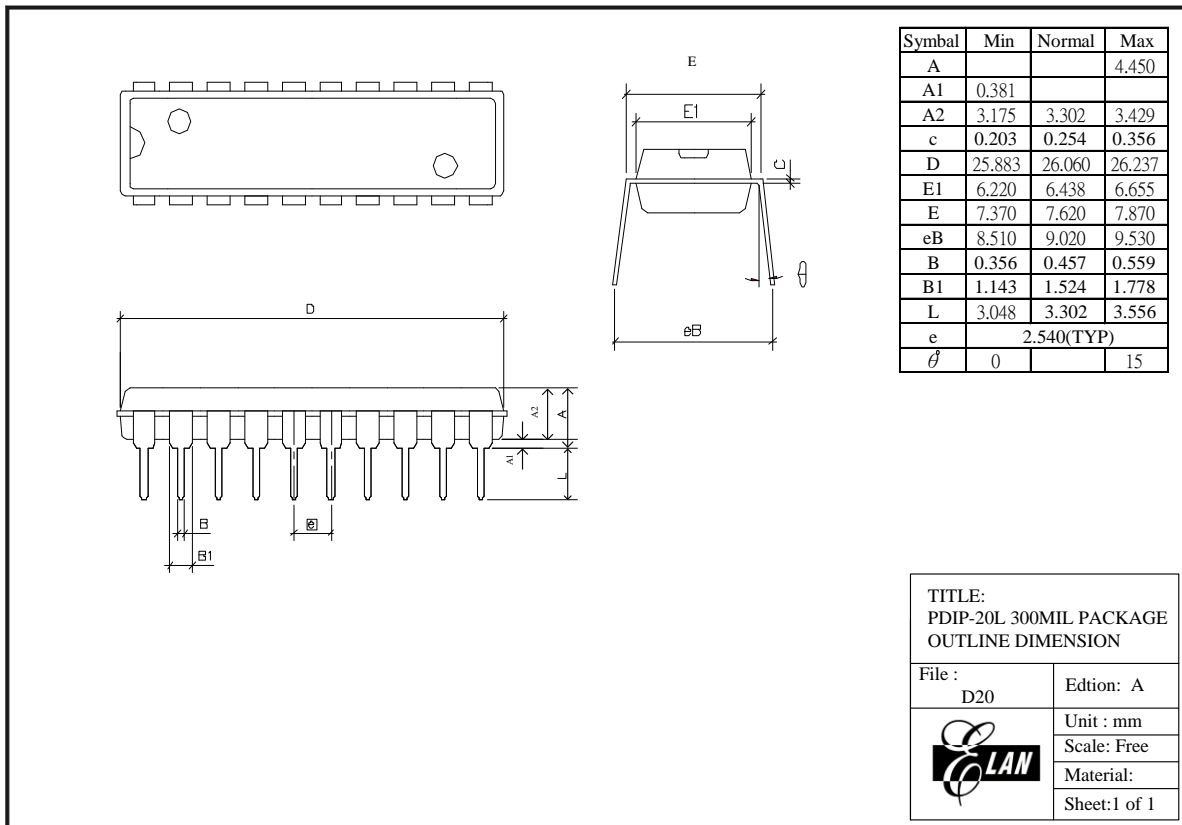

Figure B-7 EM78F734N 20-Pin PDIP Package Type

**C.8 EM78F734NSO20 300mil**

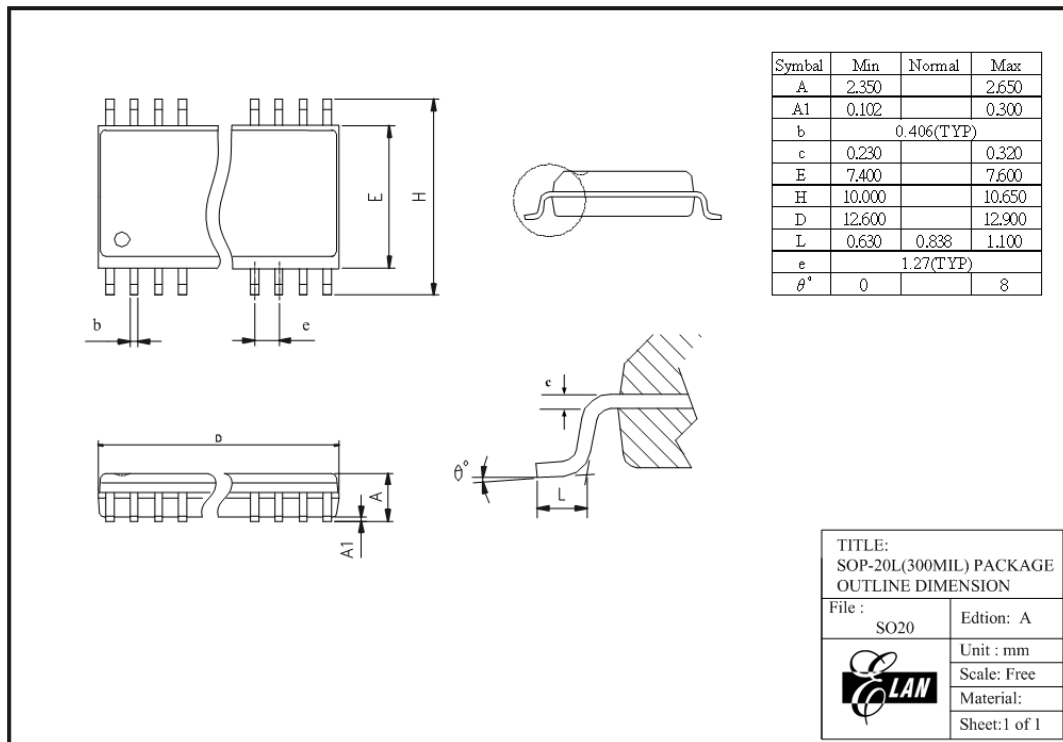

Figure B-8 EM78F734N 20-Pin SOP Package Type

C.9 EM78F734NSS20 209mil

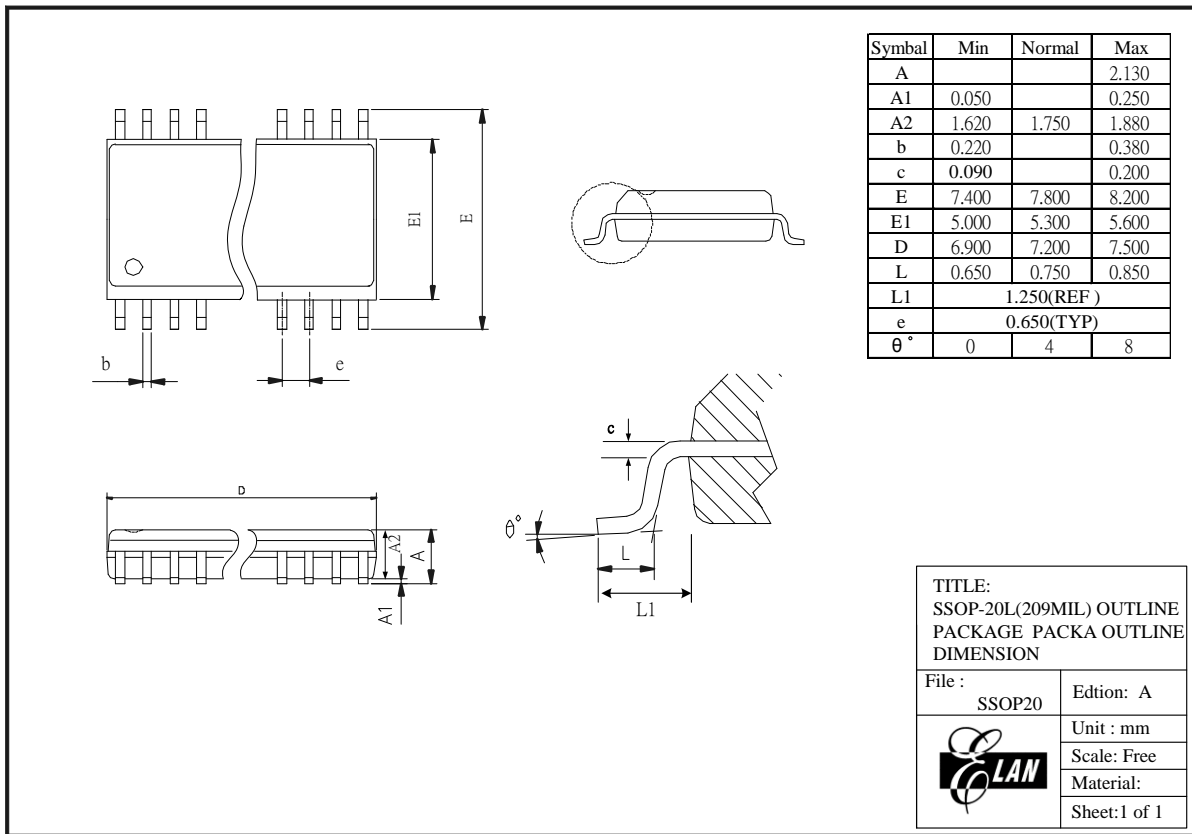

Figure B-9 EM78F734N 20-Pin SSOP Package Type

## D Quality Assurance and Reliability

Test Category	Test Conditions	Remarks
Solderability	Solder temperature= $245\pm 5^{\circ}\text{C}$ , for 5 seconds up to the stopper using a rosin-type flux	–
Pre-condition	Step 1: TCT, $65^{\circ}\text{C}$ (15mins)~ $150^{\circ}\text{C}$ (15mins), 10 cycles	For SMD IC (such as SOP, QFP, SOJ, etc)
	Step 2: Bake at $125^{\circ}\text{C}$ , TD (endurance)=24 hrs	
	Step 3: Soak at $30^{\circ}\text{C}/60\%$ , TD (endurance)=192 hrs	
	Step 4: IR flow 3 cycles (Pkg thickness $\geq 2.5\text{mm}$ or Pkg volume $\geq 350\text{mm}^3$ ---- $225\pm 5^{\circ}\text{C}$ ) (Pkg thickness $\leq 2.5\text{mm}$ or Pkg volume $\leq 350\text{mm}^3$ ---- $240\pm 5^{\circ}\text{C}$ )	
Temperature cycle test	$-65^{\circ}\text{C}$ (15mins)~ $150^{\circ}\text{C}$ (15mins), 200 cycles	–
Pressure cooker test	TA = $121^{\circ}\text{C}$ , RH=100%, pressure=2 atm, TD (endurance)= 96 hrs	–
High temperature / High humidity test	TA= $85^{\circ}\text{C}$ , RH=85% , TD (endurance) = 168 , 500 hrs	–
High-temperature storage life	TA= $150^{\circ}\text{C}$ , TD (endurance) = 500, 1000 hrs	–
High-temperature operating life	TA= $125^{\circ}\text{C}$ , VCC = Max. operating voltage, TD (endurance) = 168, 500, 1000 hrs	–
Latch-up	TA= $25^{\circ}\text{C}$ , VCC = Max. operating voltage, 150mA/20V	–
ESD (HBM)	TA= $25^{\circ}\text{C}$ , $\geq   \pm 3\text{KV}  $	IP_ND,OP_ND,IO_ND IP_NS,OP_NS,IO_NS IP_PD,OP_PD,IO_PD, IP_PS,OP_PS,IO_PS, VDD-VSS(+),VDD_VSS (-) mode
ESD (MM)	TA= $25^{\circ}\text{C}$ , $\geq   \pm 300\text{V}  $	

### D.1 Address Trap Detect

An address trap detect is one of the MCU embedded fail-safe functions that detects MCU malfunction caused by noise or the like. Whenever the MCU attempts to fetch an instruction from a certain section of ROM, an internal recovery circuit is auto started. If a noise-caused address error is detected, the MCU will repeat execution of the program until the noise is eliminated. The MCU will then continue to execute the next pr

