

To our customers,

---

## Old Company Name in Catalogs and Other Documents

---

On April 1<sup>st</sup>, 2010, NEC Electronics Corporation merged with Renesas Technology Corporation, and Renesas Electronics Corporation took over all the business of both companies. Therefore, although the old company name remains in this document, it is a valid Renesas Electronics document. We appreciate your understanding.

Renesas Electronics website: <http://www.renesas.com>

April 1<sup>st</sup>, 2010  
Renesas Electronics Corporation

Issued by: Renesas Electronics Corporation (<http://www.renesas.com>)

Send any inquiries to <http://www.renesas.com/inquiry>.

## Notice

1. All information included in this document is current as of the date this document is issued. Such information, however, is subject to change without any prior notice. Before purchasing or using any Renesas Electronics products listed herein, please confirm the latest product information with a Renesas Electronics sales office. Also, please pay regular and careful attention to additional and different information to be disclosed by Renesas Electronics such as that disclosed through our website.
2. Renesas Electronics does not assume any liability for infringement of patents, copyrights, or other intellectual property rights of third parties by or arising from the use of Renesas Electronics products or technical information described in this document. No license, express, implied or otherwise, is granted hereby under any patents, copyrights or other intellectual property rights of Renesas Electronics or others.
3. You should not alter, modify, copy, or otherwise misappropriate any Renesas Electronics product, whether in whole or in part.
4. Descriptions of circuits, software and other related information in this document are provided only to illustrate the operation of semiconductor products and application examples. You are fully responsible for the incorporation of these circuits, software, and information in the design of your equipment. Renesas Electronics assumes no responsibility for any losses incurred by you or third parties arising from the use of these circuits, software, or information.
5. When exporting the products or technology described in this document, you should comply with the applicable export control laws and regulations and follow the procedures required by such laws and regulations. You should not use Renesas Electronics products or the technology described in this document for any purpose relating to military applications or use by the military, including but not limited to the development of weapons of mass destruction. Renesas Electronics products and technology may not be used for or incorporated into any products or systems whose manufacture, use, or sale is prohibited under any applicable domestic or foreign laws or regulations.
6. Renesas Electronics has used reasonable care in preparing the information included in this document, but Renesas Electronics does not warrant that such information is error free. Renesas Electronics assumes no liability whatsoever for any damages incurred by you resulting from errors in or omissions from the information included herein.
7. Renesas Electronics products are classified according to the following three quality grades: “Standard”, “High Quality”, and “Specific”. The recommended applications for each Renesas Electronics product depends on the product’s quality grade, as indicated below. You must check the quality grade of each Renesas Electronics product before using it in a particular application. You may not use any Renesas Electronics product for any application categorized as “Specific” without the prior written consent of Renesas Electronics. Further, you may not use any Renesas Electronics product for any application for which it is not intended without the prior written consent of Renesas Electronics. Renesas Electronics shall not be in any way liable for any damages or losses incurred by you or third parties arising from the use of any Renesas Electronics product for an application categorized as “Specific” or for which the product is not intended where you have failed to obtain the prior written consent of Renesas Electronics. The quality grade of each Renesas Electronics product is “Standard” unless otherwise expressly specified in a Renesas Electronics data sheets or data books, etc.
  - “Standard”: Computers; office equipment; communications equipment; test and measurement equipment; audio and visual equipment; home electronic appliances; machine tools; personal electronic equipment; and industrial robots.
  - “High Quality”: Transportation equipment (automobiles, trains, ships, etc.); traffic control systems; anti-disaster systems; anti-crime systems; safety equipment; and medical equipment not specifically designed for life support.
  - “Specific”: Aircraft; aerospace equipment; submersible repeaters; nuclear reactor control systems; medical equipment or systems for life support (e.g. artificial life support devices or systems), surgical implantations, or healthcare intervention (e.g. excision, etc.), and any other applications or purposes that pose a direct threat to human life.
8. You should use the Renesas Electronics products described in this document within the range specified by Renesas Electronics, especially with respect to the maximum rating, operating supply voltage range, movement power voltage range, heat radiation characteristics, installation and other product characteristics. Renesas Electronics shall have no liability for malfunctions or damages arising out of the use of Renesas Electronics products beyond such specified ranges.
9. Although Renesas Electronics endeavors to improve the quality and reliability of its products, semiconductor products have specific characteristics such as the occurrence of failure at a certain rate and malfunctions under certain use conditions. Further, Renesas Electronics products are not subject to radiation resistance design. Please be sure to implement safety measures to guard them against the possibility of physical injury, and injury or damage caused by fire in the event of the failure of a Renesas Electronics product, such as safety design for hardware and software including but not limited to redundancy, fire control and malfunction prevention, appropriate treatment for aging degradation or any other appropriate measures. Because the evaluation of microcomputer software alone is very difficult, please evaluate the safety of the final products or system manufactured by you.
10. Please contact a Renesas Electronics sales office for details as to environmental matters such as the environmental compatibility of each Renesas Electronics product. Please use Renesas Electronics products in compliance with all applicable laws and regulations that regulate the inclusion or use of controlled substances, including without limitation, the EU RoHS Directive. Renesas Electronics assumes no liability for damages or losses occurring as a result of your noncompliance with applicable laws and regulations.
11. This document may not be reproduced or duplicated, in any form, in whole or in part, without prior written consent of Renesas Electronics.
12. Please contact a Renesas Electronics sales office if you have any questions regarding the information contained in this document or Renesas Electronics products, or if you have any other inquiries.

(Note 1) “Renesas Electronics” as used in this document means Renesas Electronics Corporation and also includes its majority-owned subsidiaries.

(Note 2) “Renesas Electronics product(s)” means any product developed or manufactured by or for Renesas Electronics.

7-CHANNEL H-BRIDGE DRIVER  
 WITH A MICRO STEP FUNCTION SUPPORTING PULSE INPUT

**DESCRIPTION**

The  $\mu$  PD168116A is a 7-channel H-bridge driver with a micro step function supporting pulse input that consists of a CMOS control circuit and a MOS output stage. It can reduce the current consumption and the voltage loss at the output stage compared with a conventional driver using bipolar transistors, thanks to employment of a MOS process. The  $\mu$  PD168116A can drive a stepping motor by inputting pulses, so that the number of signal lines necessary for controlling the motor can be decreased.

The package is a 56-pin WQFN that helps reduce the mounting area and height.

The  $\mu$  PD168116A can be used to drive two stepping motors, or two DC motors and one coil.

**FEATURES**

- Seven H-bridge circuits employing power MOSFET
- Low-voltage driving  
 $V_{DD} = 2.7$  to  $3.6$  V  
 $V_M = 2.7$  to  $5.5$  V
- Output on-state resistance:  $1.0 \Omega$  TYP.,  $1.5 \Omega$  MAX. (sum of top and bottom stage, ch1 to ch4, and ch7)  
 $1.5 \Omega$  TYP.,  $2.0 \Omega$  MAX. (sum of top and bottom stage, ch5 and ch6)
- PWM output (ch1 to ch6) , linear output (ch7)
- Output current  
 <ch1 to ch6>  
 DC current:  $0.4$  A/ch (when each channel is used independently)  
 Peak current:  $0.7$  A/ch (when each channel is used independently)  
 <ch7>  
 DC current:  $0.5$  A/ch (when used independently)  
 Peak current:  $0.7$  A/ch (when used independently)
- Input logic frequency:  $100$  kHz supported
- Undervoltage lockout circuit  
 Shuts down the internal circuit at  $V_{DD} = 1.7$  V TYP.
- Overheat protection circuit  
 Operates at  $150^\circ\text{C}$  or more and shuts down internal circuitry.
- 56-pin WQFN ( $8 \times 8$  mm,  $0.5$  mm pitch)

**ORDERING INFORMATION**

Part Number	Package
$\mu$ PD168116AK9-9B4-A	56-pin plastic WQFN (8 x 8)

The information in this document is subject to change without notice. Before using this document, please confirm that this is the latest version.  
 Not all products and/or types are available in every country. Please check with an NEC Electronics sales representative for availability and additional information.

1. PIN CONFIGURATION

Package: 56-pin plastic WQFN (8 x 8)

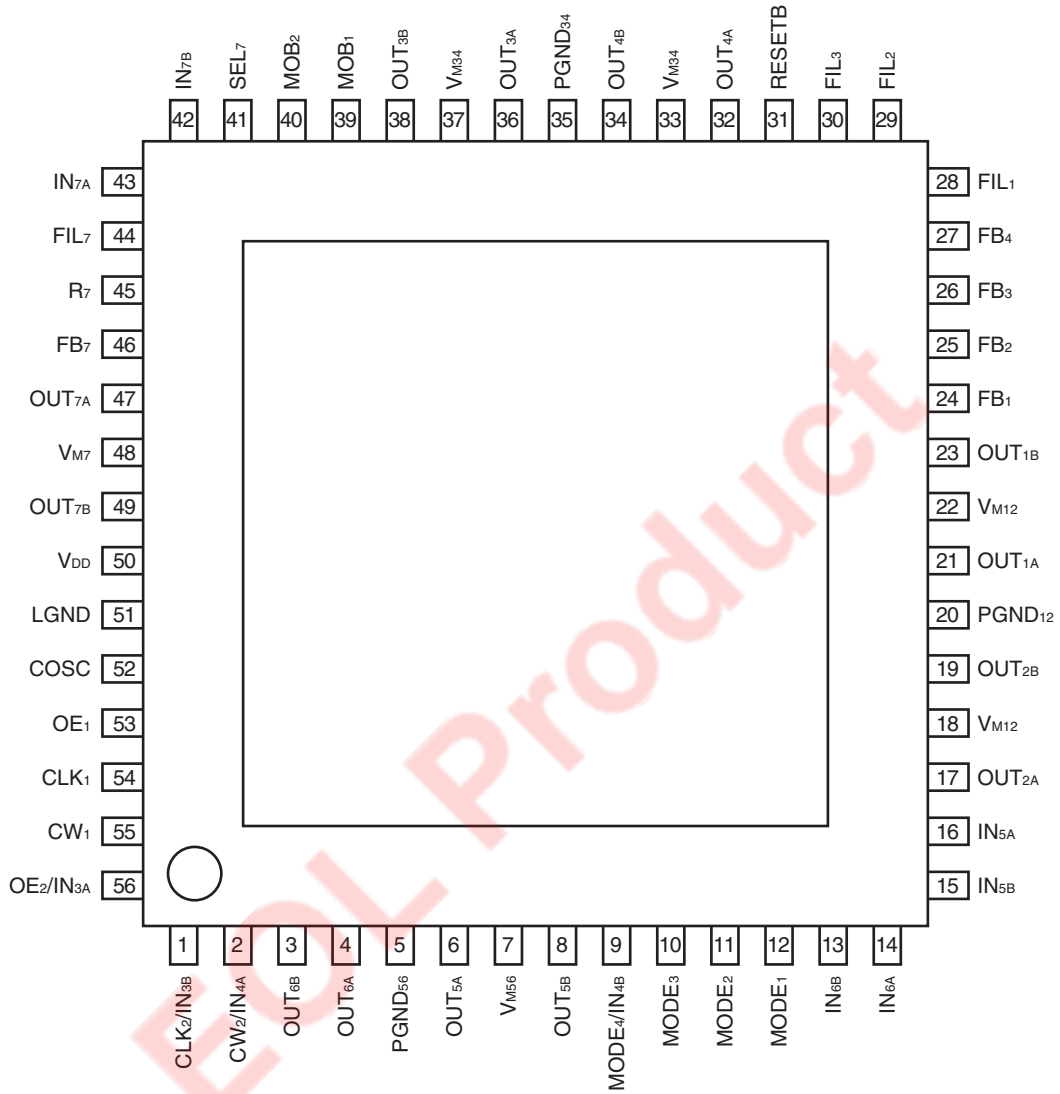

2. PIN FUNCTIONS

(1/2)

Pin No.	Pin Name	Function
1	CLK <sub>2</sub> /IN <sub>3B</sub>	H-bridge 3, H-bridge 4 CLK input pin/H-bridge 3 input pin B
2	CW <sub>2</sub> /IN <sub>4A</sub>	H-bridge 3, H-bridge 4 driving direction input pin/H-bridge 4 input pin A
3	OUT <sub>6B</sub>	H-bridge 6 output pin B
4	OUT <sub>6A</sub>	H-bridge 6 output pin A
5	PGND <sub>56</sub>	H-bridge 5, H-bridge 6 GND pin
6	OUT <sub>5A</sub>	H-bridge 5 output pin A
7	V <sub>M56</sub>	H-bridge 5, H-bridge 6 power supply pin
8	OUT <sub>5B</sub>	H-bridge 5 output pin B
9	MODE <sub>4</sub> /IN <sub>4B</sub>	Mode selection pin 4/H-bridge 4 input pin B
10	MODE <sub>3</sub>	Mode selection pin 3
11	MODE <sub>2</sub>	Mode selection pin 2
12	MODE <sub>1</sub>	Mode selection pin 1
13	IN <sub>6B</sub>	H-bridge 6 input pin B
14	IN <sub>6A</sub>	H-bridge 6 input pin A
15	IN <sub>5B</sub>	H-bridge 5 input pin B
16	IN <sub>5A</sub>	H-bridge 5 input pin A
17	OUT <sub>2A</sub>	H-bridge 2 output pin A
18	V <sub>M12</sub>	H-bridge 1, H-bridge 2 power supply pin
19	OUT <sub>2B</sub>	H-bridge 2 output pin B
20	PGND <sub>12</sub>	H-bridge 1, H-bridge 2 GND pin
21	OUT <sub>1A</sub>	H-bridge 1 output pin A
22	V <sub>M12</sub>	H-bridge 1, H-bridge 2 power supply pin
23	OUT <sub>1B</sub>	H-bridge 1 output pin B
24	FB <sub>1</sub>	Current detection resistor connection pin 1
25	FB <sub>2</sub>	Current detection resistor connection pin 2
26	FB <sub>3</sub>	Current detection resistor connection pin 3
27	FB <sub>4</sub>	Current detection resistor connection pin 4
28	FIL <sub>1</sub>	Filter capacitor connection pin 1
29	FIL <sub>2</sub>	Filter capacitor connection pin 2
30	FIL <sub>3</sub>	ch3 reference voltage output pin (Leave this pin open.)
31	RESETB	Reset pin (low active)
32	OUT <sub>4A</sub>	H-bridge 4 output pin A
33	V <sub>M34</sub>	H-bridge 3, H-bridge 4 power supply pin
34	OUT <sub>4B</sub>	H-bridge 4 output pin B
35	PGND <sub>34</sub>	H-bridge 3, H-bridge 4 GND pin
36	OUT <sub>3A</sub>	H-bridge 3 output pin A
37	V <sub>M34</sub>	H-bridge 3, H-bridge 4 power supply pin
38	OUT <sub>3B</sub>	H-bridge 3 output pin B

(2/2)

Pin No.	Pin Name	Function
39	MOB <sub>1</sub>	MOB signal output pin 1 (open drain output)
40	MOB <sub>2</sub>	MOB signal output pin 2 (open drain output)
41	SEL <sub>7</sub>	ch7 excitation mode selection pin
42	IN <sub>7B</sub>	H-bridge 7 input pin B
43	IN <sub>7A</sub>	H-bridge 7 input pin A
44	FIL <sub>7</sub>	Amplifier operation stabilizing filter connection pin
45	R <sub>7</sub>	Amplifier operation stabilizing resistor connection pin
46	FB <sub>7</sub>	Current detection resistor connection pin 7
47	OUT <sub>7A</sub>	H-bridge 7 output pin A
48	V <sub>M7</sub>	H-bridge 7 power supply pin
49	OUT <sub>7B</sub>	H-bridge 7 output pin B
50	V <sub>DD</sub>	Logic block power supply pin
51	LGND	Logic block GND pin
52	COSC	Chopping frequency setting capacitor connection pin
53	OE <sub>1</sub>	H-bridge 1, H-bridge 2 output enable pin
54	CLK <sub>1</sub>	H-bridge 1, H-bridge 2 CLK input pin
55	CW <sub>1</sub>	H-bridge 1, H-bridge 2 driving direction input pin
56	OE <sub>2</sub> /IN <sub>3A</sub>	H-bridge 3, H-bridge 4 output enable pin/H-bridge 3 input pin A

EOL Product

3. BLOCK DIAGRAM

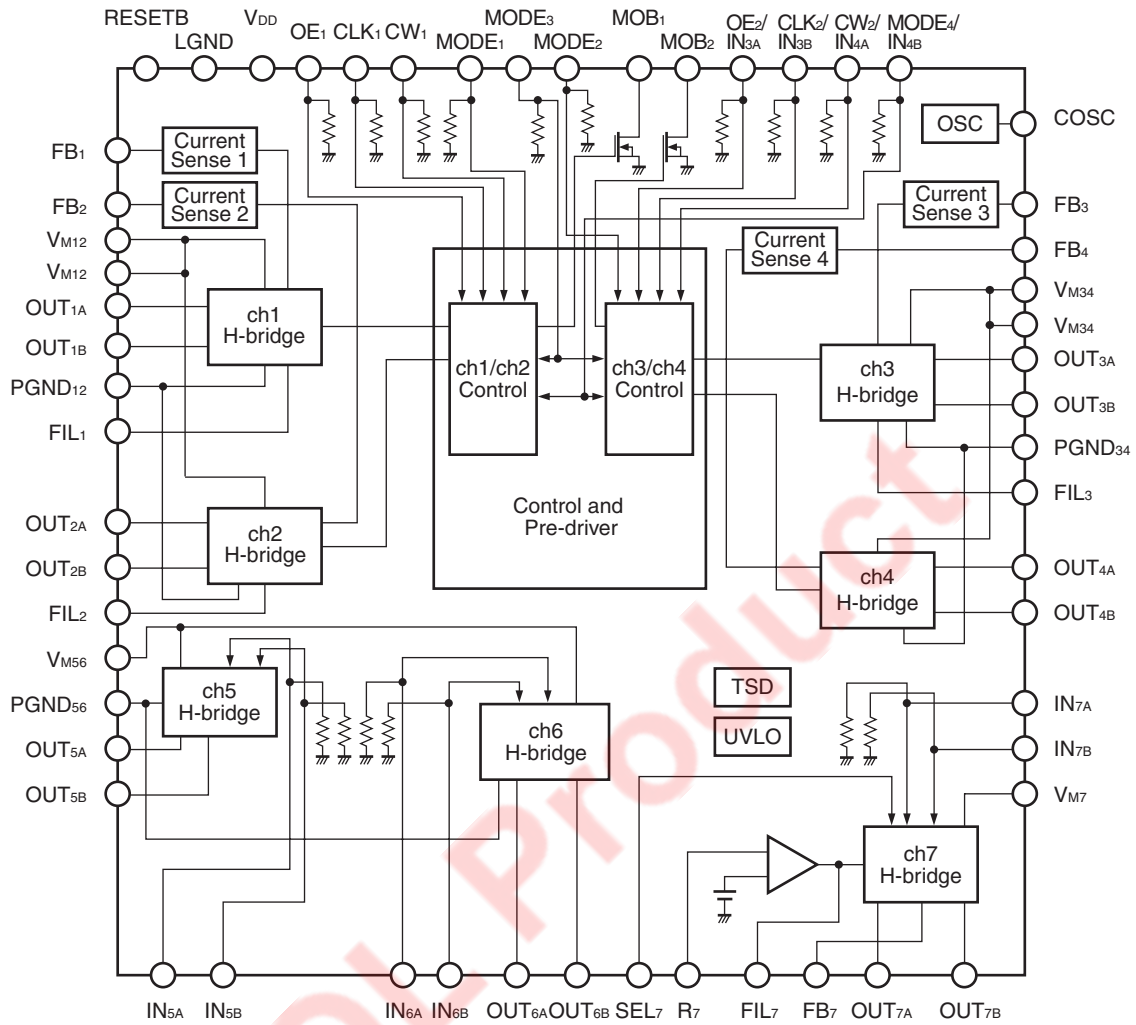

4. STANDARD CONNECTION EXAMPLE

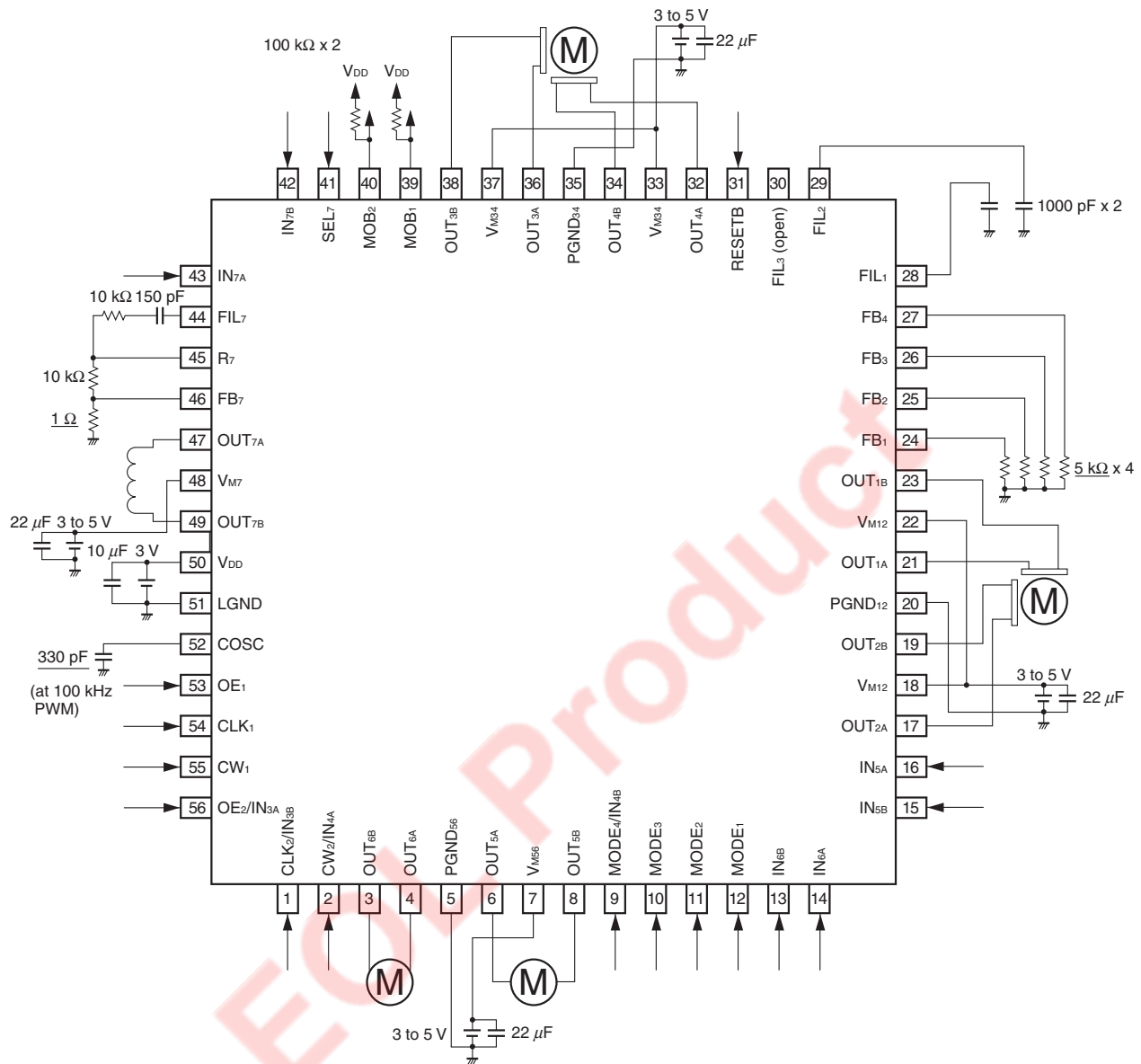

- Cautions**
1. Be sure to connect all of the pins which have more than one.
  2. The constants shown in the above diagram are provided as examples only. Perform design based on thorough evaluation with the actual machine, and change the underlined constants as necessary.
  3. A pull-down resistor (50 to 200 kΩ) is connected to the MODE<sub>1</sub>, MODE<sub>2</sub>, MODE<sub>3</sub>, SEL<sub>7</sub>, OE<sub>1</sub>, CLK<sub>1</sub>, CW<sub>1</sub>, OE<sub>2</sub>/IN<sub>3A</sub>, CLK<sub>2</sub>/IN<sub>3B</sub>, CW<sub>2</sub>/IN<sub>4A</sub>, MODE<sub>4</sub>/IN<sub>4B</sub>, IN<sub>5A</sub>, IN<sub>5B</sub>, IN<sub>6A</sub>, IN<sub>6B</sub>, IN<sub>7A</sub>, and IN<sub>7B</sub> pins. Fix these input pins to GND when they are not used.

5. SYSTEM APPLICATION DIAGRAM

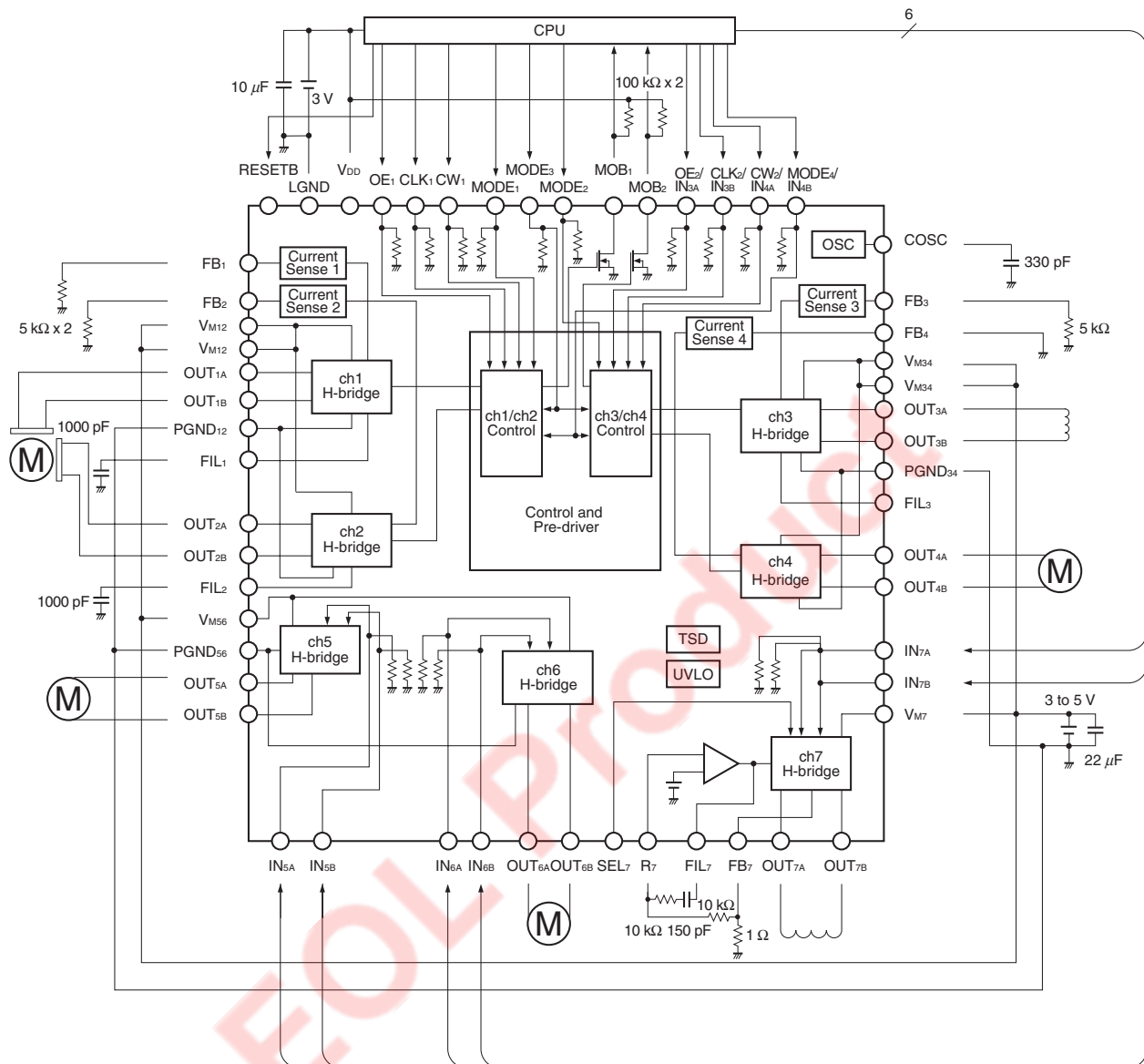

**Caution** The constants shown in the above diagram are provided as examples only. Perform design based on thorough evaluation with the actual machine.

6. FUNCTION OPERATION TABLE

6.1 Power Save Function

This IC can be placed in the power-save mode by making MODE<sub>1</sub>, MODE<sub>2</sub>, MODE<sub>3</sub>, and MODE<sub>4</sub> high level.

This function allows holding of the excitation position when the stepping motor mode is selected and the operation to be started from where the excitation position is held when the power-save mode is cleared. In the power-save mode, the current consumption is reduced to 20 μA TYP. because the internal circuits other than UVLO are stopped.

In the power-save mode, only input of the RESETB pin is acknowledged, and the other input signals are ignored.

The operation modes of ch1 to ch4 can be set by a combination of MODE<sub>1</sub> to MODE<sub>4</sub>. For the combination of the MODE pins, refer to **Table 6–1. MODE Pin Truth Table**.

Table 6–1. Mode Pin Truth Table

MODE <sub>1</sub>	MODE <sub>2</sub>	MODE <sub>3</sub>	MODE <sub>4</sub> (/IN <sub>4B</sub> )	Operation Mode	
				ch1, ch2	ch3, ch4
L	L	L	IN <sub>4B</sub> input	2-phase excitation	General-purpose driving
L	L	L		1-2 phase excitation	General-purpose driving
L	L	H			
L	L	H			
L	H	L		Micro step	General-purpose driving
L	H	L	L	2-phase excitation	2-phase excitation
L	H	H	H	1-2 phase excitation	1-2 phase excitation
H	L	L	L	2-phase excitation (current limiting)	2-phase excitation (current limiting)
H	L	L	H	1-2 phase excitation (current limiting)	1-2 phase excitation (current limiting)
H	L	H	L	2-phase excitation	Micro step
H	L	H	H	1-2 phase excitation	Micro step
H	H	L	L	Micro step	2-phase excitation
H	H	L	H	Micro step	1-2 phase excitation
H	H	H	L	Micro step	Micro step
H	H	H	H	Power save mode	

**Remark** H: High level, L: Low level

6.2 ch1, ch2 (Dedicated to Stepping Motor)

RESETB	CLK <sub>1</sub>	CW <sub>1</sub>	OE <sub>1</sub>	Operation Mode
H		L	H	Pulse progress, CW mode
H		H	H	Pulse progress, CCW mode
H	x	x	L	Output Hi-Z (Internal information is held.)
L	x	x	x	Reset mode (output Hi-Z)

**Remark** x: High level or low level, Hi-Z: High impedance

6.3 ch3, ch4 (Selecting Stepping Motor, DC Motor and Coil Driving)

<Stepping motor drive mode>

RESETB	CLK <sub>2</sub>	CW <sub>2</sub>	OE <sub>2</sub>	Operation Mode
H		L	H	Pulse progress, CW mode
H		H	H	Pulse progress, CCW mode
H	x	x	L	Output Hi-Z (Internal information is held.)
L	x	x	x	Reset mode (output Hi-Z)

<General-purpose drive mode>

RESETB	IN <sub>3A</sub> /IN <sub>4A</sub>	IN <sub>3B</sub> /IN <sub>4B</sub>	OUT <sub>3A</sub> /OUT <sub>4A</sub>	OUT <sub>3B</sub> /OUT <sub>4B</sub>	Operation Mode
H	L	L	Z	Z	Stop
H	L	H	L	H <sup>Note</sup>	Reverse
H	H	L	H <sup>Note</sup>	L	Forward
H	H	H	H	H	Brake
L	x	x	Reset mode (output Hi-Z)		

**Note** When the μ PD168116A is used for constant-current driving (when a sense resistor is connected to the FB pin) , PWM chopping driving is performed.

**Remark** Z: Output high impedance

6.4 ch5, ch6

RESETB	IN <sub>5A</sub> /IN <sub>6A</sub>	IN <sub>5B</sub> /IN <sub>6B</sub>	OUT <sub>5A</sub> /OUT <sub>6A</sub>	OUT <sub>5B</sub> /OUT <sub>6B</sub>	Operation Mode
H	L	L	Z	Z	Stop
H	L	H	L	H	Reverse
H	H	L	H	L	Forward
H	H	H	H	H	Brake
L	x	x	Reset mode (output Hi-Z)		

Forward

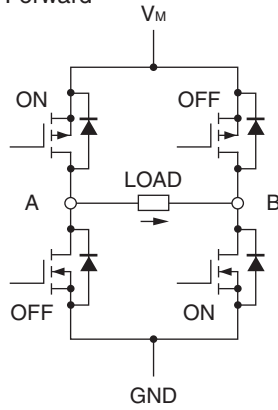

Reverse

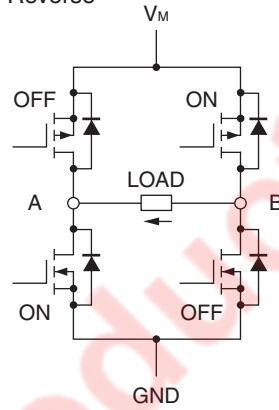

Stop

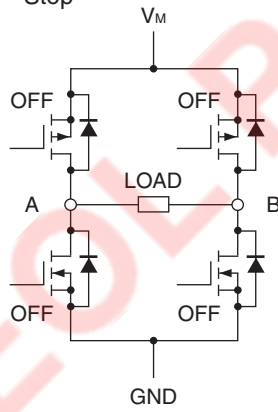

Brake

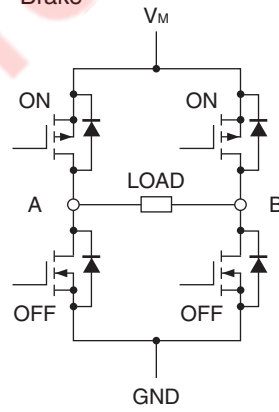

6.5 ch7

RESETB	SEL <sub>7</sub>	IN <sub>7A</sub>	IN <sub>7B</sub>	OUT <sub>7A</sub>	OUT <sub>7B</sub>	H-bridge Output State			
						Q1	Q2	Q3	Q4
H	H	L	L	Z	Z	OFF	OFF	OFF	OFF
H	H	L	H	L (linear)	H	OFF	ON	ON (linear)	OFF
H	H	H	L	H (linear)	L	ON	OFF	OFF	ON (linear)
H	H	H	L	H	H	ON	ON	OFF	OFF
H	L	Weak excitation operation when SEL <sub>7</sub> = H (Function is equivalent.)							
L	x	x	x	Z	Z	OFF	OFF	OFF	OFF

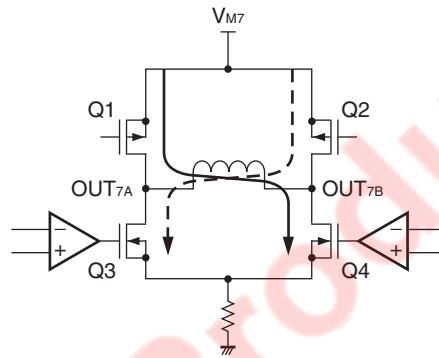

6.6 SEL<sub>7</sub> Pin

The current that flows into ch7 can be changed by setting the SEL<sub>7</sub> pin.

SEL <sub>7</sub>	Operation Mode
L	Weak excitation mode (Current 2/3 of the normal setting flows.)
H	Normal operation mode

7. COMMAND INPUT TIMING CHART

Figure 7-1. In The Micro Step Mode

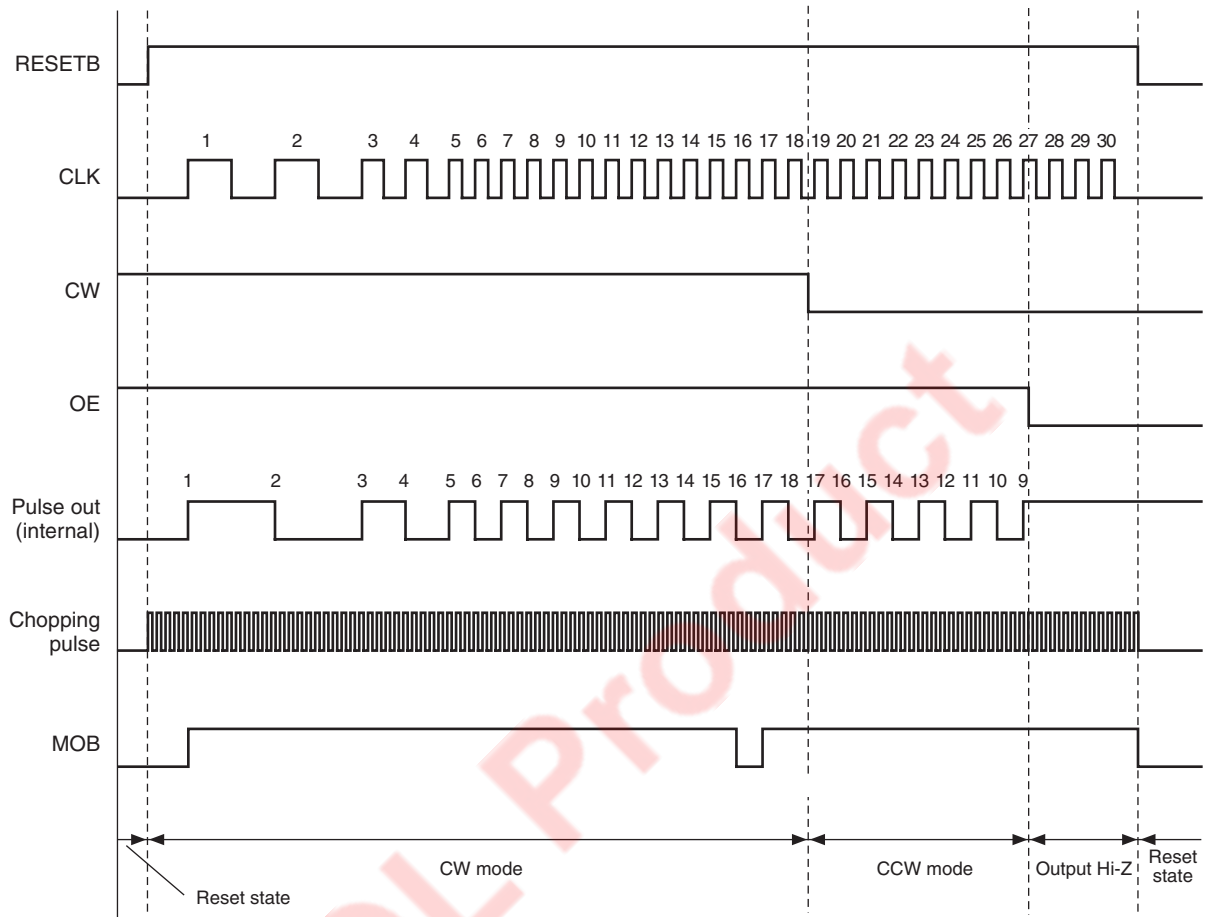

Table 7-1. Relationship between Revolution Angle, Phase Current, and Vector Amount (64 micro steps)

Step	Revolution Angle	Phase A - Phase Current			Phase B - Phase Current			Vector Amount
		MIN.	TYP.	MAX.	MIN.	TYP.	MAX.	TYP.
θ0	0	–	100	–	–	0	3.8	100
θ1	5.625	94.5	100	104.5	2.5	9.8	17.0	100.48
θ2	11.250	93.2	98.1	103.0	12.4	19.5	26.5	100
θ3	16.875	90.7	95.7	100.7	22.1	29.0	36.1	100.02
θ4	22.500	87.4	92.4	97.4	31.3	38.3	45.3	100.02
θ5	28.125	83.2	88.2	93.4	40.1	47.1	54.1	99.99
θ6	33.750	78.1	83.1	88.1	48.6	55.6	62.6	99.98
θ7	39.375	72.3	77.3	82.3	58.4	63.4	68.4	99.97
θ8	45	65.7	70.7	75.7	65.7	70.7	75.7	99.98
θ9	50.625	58.4	63.4	68.4	72.3	77.3	82.3	99.97
θ10	56.250	48.6	55.6	62.6	78.1	83.1	88.1	99.98
θ11	61.875	40.1	47.1	54.1	83.2	88.2	93.2	99.99
θ12	67.500	31.3	38.3	45.3	87.4	92.4	97.4	100.02
θ13	73.125	22.1	29.0	36.1	90.7	95.7	100.7	100.02
θ14	78.750	12.4	19.5	26.5	93.2	98.1	103.0	100
θ15	84.375	2.5	9.8	17.0	94.5	100	104.5	100.48
θ16	90	–	0	3.8	–	100	–	100

**Caution** θ0 shows the excitation start position after release of reset. Each value is an ideal value and is not a guarantee value.

## 8. FUNCTIONAL DEPLOYMENT

### 8.1 Reset Function

An initialization operation is performed and all the internal data is cleared when RESETB = L. The output remains in the Hi-Z state.

When RESETB = H, signals can be input. Be sure to perform a reset operation after turning on power supply.

When RESETB = L, the internal circuitry is stopped whenever possible, so that the self current consumption can be reduced. When the external input signal is stopped, the current consumption can be lowered to 1  $\mu$ A MAX.

Immediately after release of reset, excitation is started from the position where the current of ch1 is 100% and the current of ch2 is 0%, in the micro step drive mode and 1-2 phase excitation drive mode. In the 2-phase excitation drive mode, excitation is started from the position where the currents of ch1 and ch2 are 100%.

### 8.2 2-phase Excitation Drive Mode and 1-2 Phase Excitation Drive Mode

In the 2-phase excitation drive mode, current of  $\pm 100\%$  is allowed to flow into ch1 and ch2 simultaneously. In the 1-2 phase excitation drive mode, the motor can be driven at a higher torque by allowing a current to flow so that the synthesized torque of ch1 and ch2 is the same as the torque at phase 1 position. The 2-phase excitation, 1-2 phase excitation, and micro step driving modes are selected by the MODE<sub>1</sub> to MODE<sub>4</sub> pins.

**Note that 100% (= saturation drive mode) and a mode in which the current set by the sense resistor is used can be selected by the MODE pin. Current control is performed by chopping drive.**

### 8.3 Micro Step Drive Mode of Stepping Motor

The current flowing into the H-bridge is constant by using a vector value so that one period can be stopped in 1/64 steps. This function is provided to realize high-accuracy positioning control of a stepping motor.

To realize this micro step driving, the following functions are internally realized by the driver.

- Detection of current flowing into each channel by sense resistor as voltage value
- Synthesizing half the dummy sine waveform generated by the internal D/A with PWM oscillation waveform for chopping operation
- Driver stage performing PWM drive based on result of comparing detected voltage and synthesized waveform

Because the internal dummy sine wave consists of 64 steps per period, it can be used to drive a stepping motor using 64 divisions. The micro step drive mode, 2-phase excitation drive mode, and 1-2 phase excitation drive mode can be selected by using external pins.

Figure 8-1. Concept of Micro Step Drive Operation

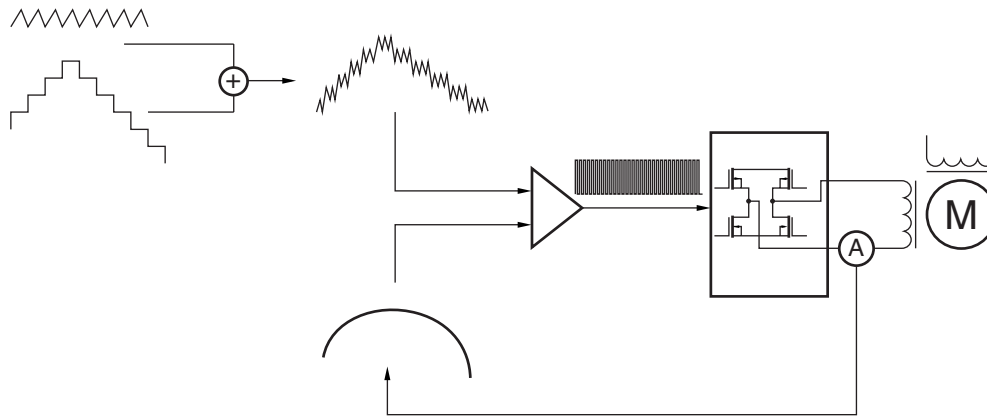

### 8.4 Output Enable (OE) Pin

The OE<sub>1</sub> (OE<sub>2</sub>) pin can be used to forcibly stop pulse output of ch1 and ch2 (or ch3 and ch4) .

When OE<sub>1</sub> (OE<sub>2</sub>) = L, the output is forcibly made to go into Hi-Z. Because the internal information is held, however, the motor position information is recorded unless reset is performed.

To drive a motor, make sure that OE<sub>1</sub> (OE<sub>2</sub>) = H.

### 8.5 MOB Output

In the micro step drive mode, L is output from the MOB<sub>1</sub> (MOB<sub>2</sub>) pin when the current of ch1 (ch3) or ch2 (ch4) is ±100%.

In the 2-phase excitation or 1-2 phase excitation drive mode, L is output when the current of ch1 and ch2 is +100%.

By monitoring the MOB output, the excitation position of the stepping motor can be checked. When OE<sub>1</sub> (OE<sub>2</sub>) = L, MOB<sub>1</sub> (MOB<sub>2</sub>) = Hi-Z.

### 8.6 Current Detection Resistor Connection (FB) Pin

#### (1) ch1 to ch4

The current detection resistor is connected when current driving is necessary. It is used for micro step driving and solenoid driving.

The current that flows into the output is {500 mV (reference voltage) /FB pin resistance x 1000}.

Example) Where FB = 4.7 kΩ  
 Output current = 500 (mV) /4.7 (kΩ) x 1000  
 ≅ 106 (mA)

This means constant current driving of about 106 mA.

When current driving is not performed, connect the FB pin to GND.

**(2) ch7**

Connect the current detection circuit between the source of the driver low side and GND. Because the circuit is configured to detect current directly, connect a detection resistor of low resistance (1  $\Omega$  maximum) .

The current that flows into the output is {200 mV (reference voltage) /FB<sub>7</sub> pin resistance} (when SEL<sub>7</sub> = H) .

Example) Where FB<sub>7</sub> = 0.5  $\Omega$   
Output current = 200 (mV) /0.5 ( $\Omega$ )  
= 400 (mA)

This means constant current driving of 400 mA.

Because only ch7 employs the linear drive mode and directly detects the output current, the current accuracy is determined only by the external resistor and the offset of the current control amplifier.

**8.7 Undervoltage Lockout (UVLO) Circuit**

This function is to forcibly stop the operation of the IC to prevent malfunctioning if V<sub>DD</sub> drops.

When UVLO operates, the IC is in the reset status.

If V<sub>DD</sub> drops abruptly in the order of several  $\mu$ s, this function may not operate.

**8.8 Overheat Protection (TSD) Circuit**

This function is to forcibly stop the operation of the IC to protect it from destruction due to overheating if the chip temperature of the IC rises.

The overheat protection circuit operates when the chip temperature rises to 150°C or more. When overheat is detected, all the circuits are stopped. When RESETB = L or when UVLO is detected, the overheat protection circuit does not operate.

**8.9 Power Up Sequence**

This IC has a circuit that prevents current from flowing into the V<sub>M</sub> pin when V<sub>DD</sub> = 0 V. Therefore, the current that flows into the V<sub>M</sub> pin is cut off when V<sub>DD</sub> = 0 V.

Because the V<sub>DD</sub> pin voltage and V<sub>M</sub> pin voltage are monitored, a current of 3  $\mu$ A MAX. flows into the V<sub>M</sub> pin when V<sub>DD</sub> is applied.

9. OPERATION DESCRIPTION

9.1 Output Current Setting

The peak value of the output current (100% of the current of ch1 (ch3) or ch2 (ch4) ) is determined by resistor  $R_{FB}$  connected to  $FB_1$  ( $FB_3$ ) or  $FB_2$  ( $FB_4$ ) . This IC has reference power supply  $V_{REF}$  (500 mV TYP.) for current comparison, and performs driving with the current obtained from  $R_{FB}$  and  $V_{REF}$  as the peak output current.

$$\text{Peak output current: } I_{MAX} \text{ (A)} \cong V_{REF} \text{ (V)} \div R_{FB} \text{ (\Omega)} \times 1000$$

9.2 Pulse Output

The motor is driven by inputting a pulse to the  $CLK_1$  ( $CLK_2$ ) pin. The operation advances by one pulse at the rising edge of the  $CLK_1$  ( $CLK_2$ ) signal.

9.3 Motor Revolution Direction Setting

$CLK_1$  ( $CLK_2$ ) is used to specify the motor revolution direction.

In the CW mode, the current of ch2 (ch4) is output, 90° degrees in phase behind the current of ch1 (ch3) .

In the CCW mode, the current of ch2 (ch4) is output, 90° degrees in phase ahead of the current of ch1 (ch3) .

9.4 Selecting 2-phase Excitation/Micro Step Drive Mode

The 2-phase excitation, 1-2 phase excitation, or micro step drive mode can be selected by using the  $MODE_1$  to  $MODE_4$  pins.

Refer to **Table 6–1. Mode Pin Truth Table** for details.

Immediately after release of reset, the IC is initialized. In the 1-2 phase excitation and micro step drive mode, excitation is started from the position where the output current of ch1 (ch3) is 100% and output current of ch2 (ch4) is 0%. In the 2-phase excitation drive mode, excitation is started from the position where the currents of both ch1 (ch3) and ch2 (ch4) are +100%.

When the mode is changed from the micro step driving to the 2-phase excitation (or 1-2 phase excitation) , the position of micro step is held until CLK is input. Pulse output is started by the first CLK input, the position is skipped to the 2-phase position of the next quadrant (or to the closest 1-2 phase position at the rotation direction destination) , and driving is started.

Figure 9–1. Concept of Change Operation, Micro Step Driving ↔ 2-phase Excitation (1-2 Phase Excitation) .

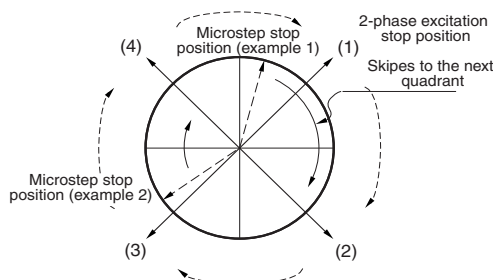

## 10. NOTE ON CORRECT USE

### 10.1 Transmitting Data

Data input when RESETB = L is ignored.

### 10.2 Pin Processing of Unused Circuit

The input/output pins of an unused circuit must be processed as specified below.

A  $V_M$  power supply pin is provided for each output circuit. The current consumption of the internal circuit can be reduced by dropping the  $V_M$  power of the unused circuit to GND. However, if there are multiple power supply pins, be sure to connect all of them to the same potential.

#### <ch1, ch2>

Lower OE<sub>1</sub>, CLK<sub>1</sub>, and CW<sub>1</sub>.

Open FIL<sub>1</sub>, FIL<sub>2</sub>, OUT<sub>1A</sub>, OUT<sub>1B</sub>, OUT<sub>2A</sub>, and OUT<sub>2B</sub>.

Connect FB<sub>1</sub> and FB<sub>2</sub> to GND.

#### <ch3, ch4>

Set the general-purpose drive mode.

Lower OE<sub>2</sub>/IN<sub>3A</sub>, CLK<sub>2</sub>/IN<sub>3B</sub>, CW<sub>2</sub>/IN<sub>4A</sub>, and MODE<sub>4</sub>/IN<sub>4B</sub>.

Open FIL<sub>3</sub>, OUT<sub>3A</sub>, OUT<sub>3B</sub>, OUT<sub>4A</sub>, and OUT<sub>4B</sub>.

Connect FB<sub>3</sub> and FB<sub>4</sub> to GND.

#### <ch5, ch6>

Lower IN<sub>5A</sub> (IN<sub>6A</sub>) and IN<sub>5B</sub> (IN<sub>6B</sub>).

Open OUT<sub>5A</sub> (OUT<sub>6A</sub>) and OUT<sub>5B</sub> (OUT<sub>6B</sub>).

#### <ch7>

Lower SEL<sub>7</sub>, IN<sub>7A</sub>, and IN<sub>7B</sub>.

Open OUT<sub>7A</sub> and OUT<sub>7B</sub>.

Connect FIL<sub>7</sub>, FB<sub>7</sub>, and R<sub>7</sub> to GND.

11. STEPPING MOTOR DRIVING WAVEFORM

Figure 11-1. 2-phase Excitation Output Mode

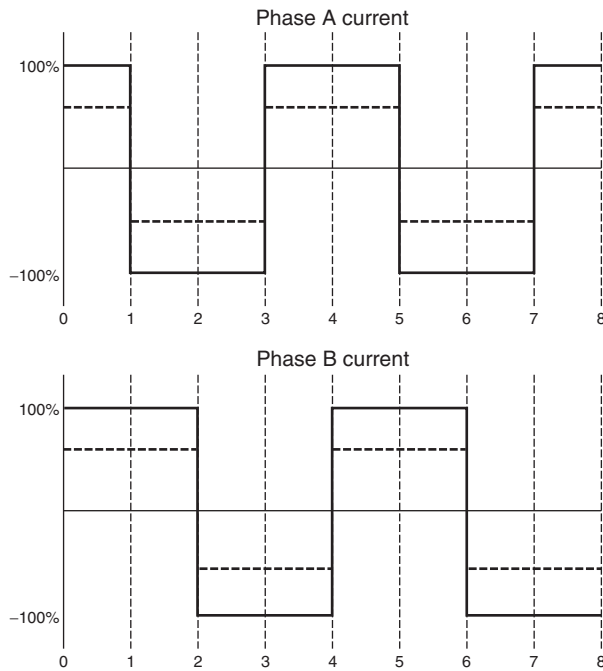
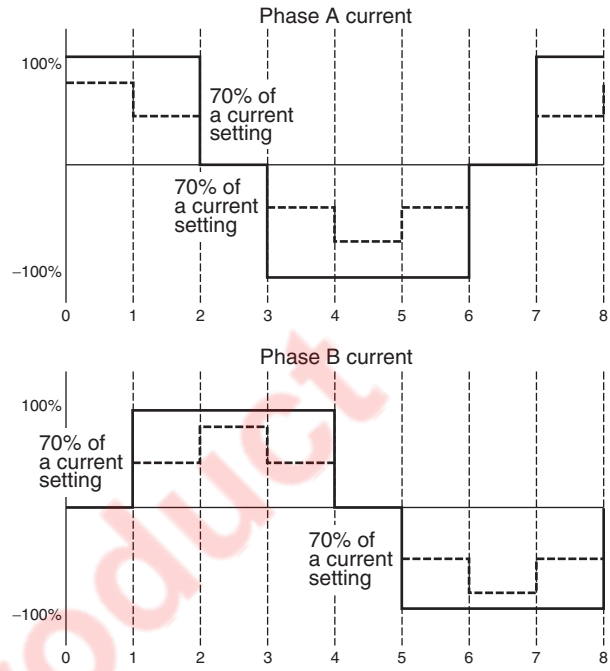

Figure 11-2. 1-2 Phase Excitation Output Mode



**Remarks 1.** Solid line: Output duty 100% drive, Dotted line: Current control drive (The current is in accordance with the current setting.)

**2.** The horizontal axis of the above charts indicates the number of steps. The above charts show an example in the CW (forward) mode.

The current flowing into phases A and B is positive in the direction from OUT pin A to OUT pin B, and negative in the direction from OUT pin B to OUT pin A.

Figure 11–3. Micro Step Drive Mode

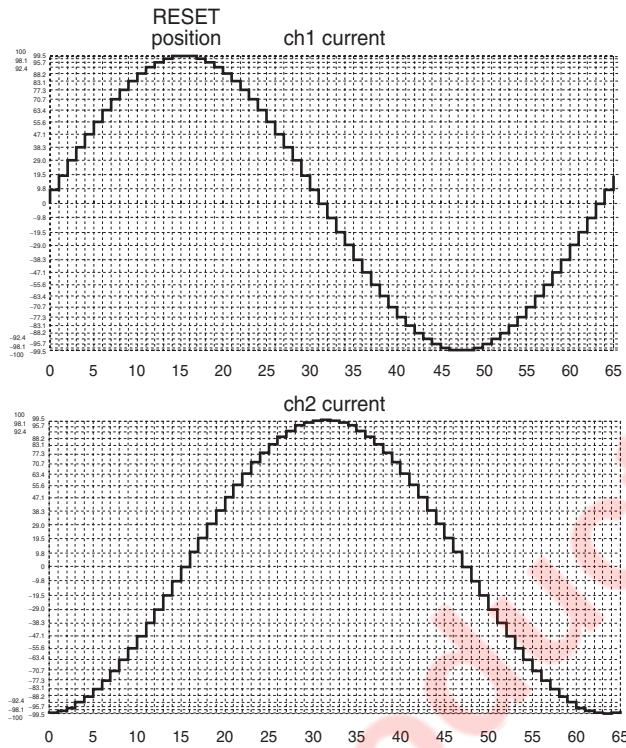

**Remark** The horizontal axis of the above charts indicates the number of steps. The above charts show an example in the CW (forward) mode.

The current flowing into phases A and B is positive in the direction from OUT pin A to OUT pin B, and negative in the direction from OUT pin B to OUT pin A.

12. ELECTRICAL SPECIFICATIONS

**Absolute Maximum Ratings** ( $T_A = 25^\circ\text{C}$ , glass epoxy board of 100 mm x 100 mm x 1 mm with copper foil area of 15%)

Parameter	Symbol	Condition	Rating	Unit
Power supply voltage	$V_{DD}$	Control block	-0.5 to +6.0	V
	$V_M$	Motor block	-0.5 to +6.0	V
Input voltage	$V_{IN}$		-0.5 to $V_{DD} + 0.5$	V
Output pin voltage	$V_{OUT}$	Motor block	6.2	V
DC output current (ch1 to 6ch)	$I_{D(DC)}$	DC (during output independent operation)	$\pm 0.4$	A/ch
DC output current (ch7)	$I_{D(DC)}$	DC (during output independent operation)	$\pm 0.5$	A/ch
Instantaneous output current	$I_{D(pulse)}$	PW < 10 ms, Duty Cycle $\leq 20\%$ (during output independent operation)	$\pm 0.7$	A/ch
Power consumption	$P_T$		1.0	W
Peak junction temperature	$T_{ch(MAX)}$		150	$^\circ\text{C}$
Storage temperature	$T_{stg}$		-55 to +150	$^\circ\text{C}$

**Remark** The overheat protection circuit operates at  $T_{ch} > 150^\circ\text{C}$ . When overheat is detected, all the circuits are stopped. The overheat protection circuit does not operate at reset or on detection of ULVO.

**Caution** Product quality may suffer if the absolute maximum rating is exceeded even momentarily for any parameter. That is, the absolute maximum ratings are rated values at which the product is on the verge of suffering physical damage, and therefore the product must be used under conditions that ensure that the absolute maximum ratings are not exceeded.

**Recommended Operating Conditions** ( $T_A = 25^\circ\text{C}$ , glass epoxy board of 100 mm x 100 mm x 1 mm with copper foil area of 15%)

Parameter	Symbol	Condition	MIN.	TYP.	MAX.	Unit
Power supply voltage	$V_{DD}$	Control block	2.7		3.6	V
	$V_M$	Motor block	2.7		5.5	V
Input voltage	$V_{IN}$		0		$V_{DD}$	V
DC output current (ch1 to 6ch)	$I_{D(DC)}$	DC (during output independent operation)	-0.3		+0.3	A/ch
DC output current (ch7)	$I_{D(DC)}$	DC (during output independent operation)	-0.4		+0.4	A/ch
Instantaneous output current	$I_{D(pulse)}$	PW < 10 ms, Duty Cycle $\leq 20\%$ (during output independent operation)	-0.6		+0.6	A/ch
Capacitor capacitance		COSC		330		pF
MOB pin output sink current	$I_{MOB}$	Open-drain output			5	mA
Logic input frequency	$f_{IN}$				100	kHz
Operating temperature range	$T_A$		-10		75	$^\circ\text{C}$

**Electrical Characteristics (Unless otherwise specified, T<sub>A</sub> = 25°C, V<sub>DD</sub> = 3.0 V, V<sub>M</sub> = 3.0 V)**

Parameter	Symbol	Condition	MIN.	TYP.	MAX.	Unit
V <sub>DD</sub> pin current in standby mode	I <sub>DD(STB)</sub>	RESETB pin: Low level			1.0	μA
V <sub>DD</sub> pin current in during operation	I <sub>DD(ACT)</sub>	RESETB pin: High level			5.0	mA
High-level input current	I <sub>IH</sub>	V <sub>IN</sub> = V <sub>DD</sub>			60	μA
Low-level input current	I <sub>IL</sub>	V <sub>IN</sub> = 0 V	-1.0			μA
Input pulldown resistance	R <sub>IND</sub>		50		200	kΩ
High-level input voltage	V <sub>IH</sub>	2.7 V ≤ V <sub>DD</sub> ≤ 3.6 V	0.7 x V <sub>DD</sub>			V
Low-level input voltage	V <sub>IL</sub>	2.7 V ≤ V <sub>DD</sub> ≤ 3.6 V			0.3 x V <sub>DD</sub>	V
COSC oscillation frequency	f <sub>OSC</sub>	COSC = 330 pF		100		kHz
H-bridge on-state resistance	R <sub>on</sub>	I <sub>M</sub> = 0.3 A, sum of upper and lower stages (ch1 to ch4, and ch7)		1.0	1.5	Ω
	R <sub>on56</sub>	I <sub>M</sub> = 0.3 A, sum of upper and lower stages (ch5 and ch6)		1.5	2.0	Ω
Output leakage current <sup>Note1</sup>	I <sub>M(off)</sub>	Per V <sub>M</sub> pin, All control pin: low level			1.0	μA
Low-voltage detection voltage	V <sub>DDS</sub>			1.7	2.5	V
Internal reference voltage <sup>Note2</sup>	V <sub>REF</sub>	ch1 to ch4	450	500	550	mV
	V <sub>REF7</sub>	ch7	180	200	220	mV
Current detection ratio <sup>Note2</sup>		I <sub>M</sub> = 0.1 A, with sense resistor of 2 kΩ, ch1 to ch4	950	1050	1150	
Output turn-on time	t <sub>on</sub>	R <sub>L</sub> = 20 Ω	0.02	0.35	1.0	μs
Output turn-off time	t <sub>off</sub>		0.02	0.35	1.0	μs

**Notes 1.** This IC has a circuit that prevents current from flowing into the V<sub>M</sub> pin when V<sub>DD</sub> = 0 V.

- 2.** The motor current accuracy varies depending on the motor actually used. With this IC, the total of the reference voltage EVRMAX error and the current sense circuit error is within ±10%.

13. PACKAGE DRAWING

56-PIN PLASTIC WQFN (8x8)

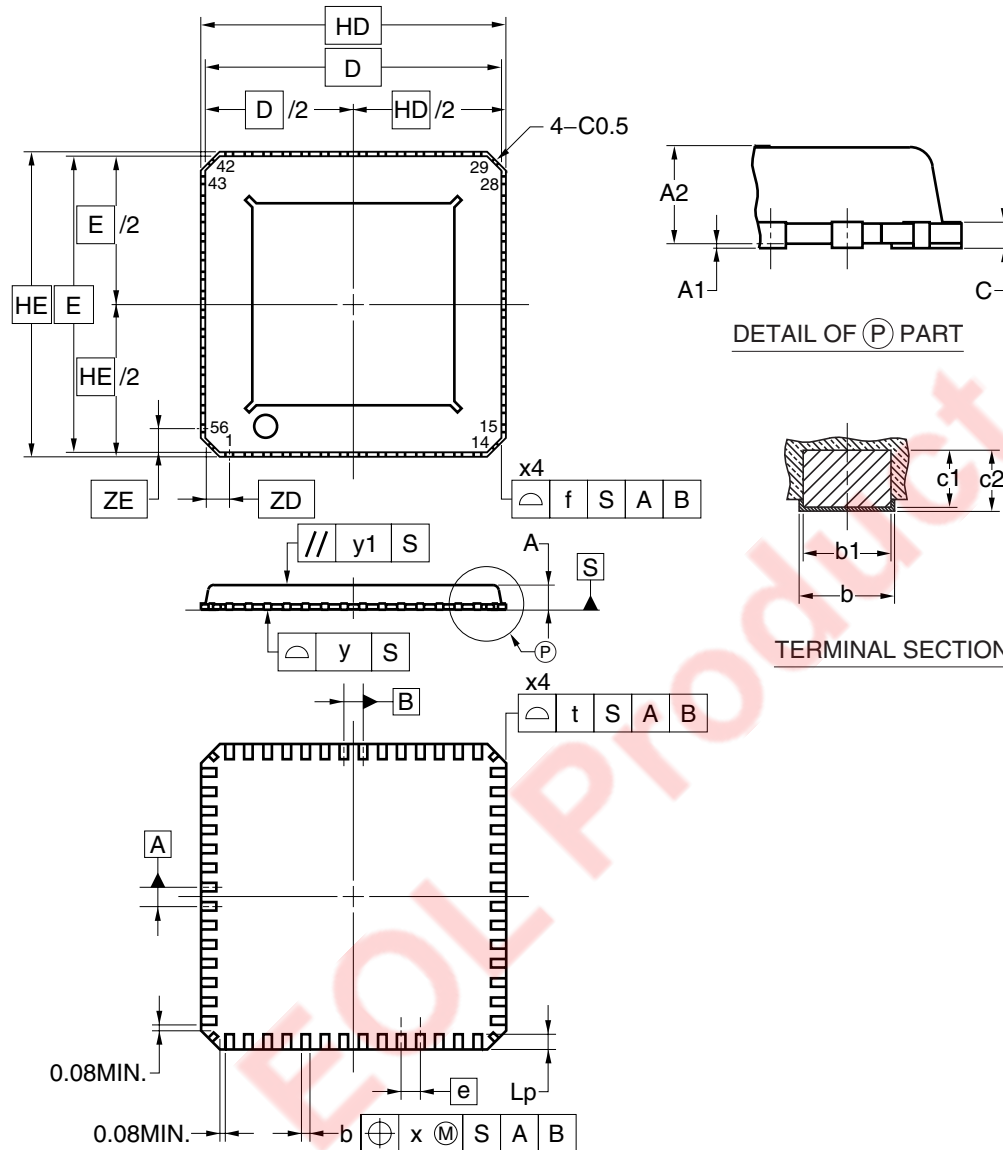

(UNIT:mm)

ITEM	DIMENSIONS
D	7.75
E	7.75
f	0.20
HD	8.00
HE	8.00
t	0.20
A	0.67 <sup>+0.08</sup> <sub>-0.04</sub>
A1	0.03 <sup>+0.02</sup> <sub>-0.025</sub>
A2	0.64
b	0.23±0.05
b1	0.20±0.03
c	0.17
c1	0.14-0.16
c2	0.14-0.20
e	0.50
Lp	0.40±0.10
x	0.05
y	0.08
y1	0.10
ZD	0.625
ZE	0.625

NOTES

- ※1 "t" AND "f" EXCLUDES MOLD FLASH
- ※2 ALTHOUGH THERE ARE 4 TERMINALS IN THE CORNER PART OF A PACKAGE, THESE TERMINALS ARE NOT DESIGNED FOR INTERCONNECTION, BUT FOR MANUFACTURING PROCESS OF THE PACKAGE, THEREFOR DO NOT INTEND TO SOLDER THESE 4 TERMINALS, SOLDERABILITY OF THE 4 TERMINALS ARE NOT GUARANTEED.

P56K9-50-9B4

**14. RECOMMENDED SOLDERING CONDITIONS**

The μ PD168116A should be soldered and mounted under the following recommended conditions.

For soldering methods and conditions other than those recommended below, contact an NEC Electronics sales representative.

For technical information, see the following website.

**Semiconductor Device Mount Manual (<http://www.necel.com/pkg/en/mount/index.html>)**

**Type of Surface Mount Device**

μ PD168116AK9-9B4-A: 56-pin plastic WQFN (8 x 8)

Process	Conditions	Symbol
Infrared reflow	Package peak temperature: 260°C, Time: 60 seconds MAX. (at 220°C or higher) , Count: Three times or less, Exposure limit: 3 days <sup>Note</sup> (after that, prebake at 125°C for 10 hours) , Flux: Rosin flux with low chlorine (0.2 Wt% or below) recommended. <Precaution> Products other than in heat-resistant trays (such as those packaged in a magazine, taping, or non-thermal-resistant tray) cannot be baked in their package.	IR60-103-3

**Note** After opening the dry pack, store it a 25°C or less and 65% RH or less for the allowable storage period.

**Caution** Do not use different soldering methods together (except for partial heating) .

**NOTES FOR CMOS DEVICES****① PRECAUTION AGAINST ESD FOR SEMICONDUCTORS**

Note:

Strong electric field, when exposed to a MOS device, can cause destruction of the gate oxide and ultimately degrade the device operation. Steps must be taken to stop generation of static electricity as much as possible, and quickly dissipate it once, when it has occurred. Environmental control must be adequate. When it is dry, humidifier should be used. It is recommended to avoid using insulators that easily build static electricity. Semiconductor devices must be stored and transported in an anti-static container, static shielding bag or conductive material. All test and measurement tools including work bench and floor should be grounded. The operator should be grounded using wrist strap. Semiconductor devices must not be touched with bare hands. Similar precautions need to be taken for PW boards with semiconductor devices on it.

**② HANDLING OF UNUSED INPUT PINS FOR CMOS**

Note:

No connection for CMOS device inputs can be cause of malfunction. If no connection is provided to the input pins, it is possible that an internal input level may be generated due to noise, etc., hence causing malfunction. CMOS devices behave differently than Bipolar or NMOS devices. Input levels of CMOS devices must be fixed high or low by using a pull-up or pull-down circuitry. Each unused pin should be connected to  $V_{DD}$  or GND with a resistor, if it is considered to have a possibility of being an output pin. All handling related to the unused pins must be judged device by device and related specifications governing the devices.

**③ STATUS BEFORE INITIALIZATION OF MOS DEVICES**

Note:

Power-on does not necessarily define initial status of MOS device. Production process of MOS does not define the initial operation status of the device. Immediately after the power source is turned ON, the devices with reset function have not yet been initialized. Hence, power-on does not guarantee out-pin levels, I/O settings or contents of registers. Device is not initialized until the reset signal is received. Reset operation must be executed immediately after power-on for devices having reset function.

**Reference Documents****NEC Semiconductor Device Reliability/Quality Control System (C10983E)****Quality Grades On NEC Semiconductor Devices (C11531E)**

- **The information in this document is current as of December, 2003. The information is subject to change without notice. For actual design-in, refer to the latest publications of NEC Electronics data sheets or data books, etc., for the most up-to-date specifications of NEC Electronics products. Not all products and/or types are available in every country. Please check with an NEC Electronics sales representative for availability and additional information.**
- No part of this document may be copied or reproduced in any form or by any means without the prior written consent of NEC Electronics. NEC Electronics assumes no responsibility for any errors that may appear in this document.
- NEC Electronics does not assume any liability for infringement of patents, copyrights or other intellectual property rights of third parties by or arising from the use of NEC Electronics products listed in this document or any other liability arising from the use of such products. No license, express, implied or otherwise, is granted under any patents, copyrights or other intellectual property rights of NEC Electronics or others.
- Descriptions of circuits, software and other related information in this document are provided for illustrative purposes in semiconductor product operation and application examples. The incorporation of these circuits, software and information in the design of a customer's equipment shall be done under the full responsibility of the customer. NEC Electronics assumes no responsibility for any losses incurred by customers or third parties arising from the use of these circuits, software and information.
- While NEC Electronics endeavors to enhance the quality, reliability and safety of NEC Electronics products, customers agree and acknowledge that the possibility of defects thereof cannot be eliminated entirely. To minimize risks of damage to property or injury (including death) to persons arising from defects in NEC Electronics products, customers must incorporate sufficient safety measures in their design, such as redundancy, fire-containment and anti-failure features.
- NEC Electronics products are classified into the following three quality grades: "Standard", "Special" and "Specific".

The "Specific" quality grade applies only to NEC Electronics products developed based on a customer-designated "quality assurance program" for a specific application. The recommended applications of an NEC Electronics product depend on its quality grade, as indicated below. Customers must check the quality grade of each NEC Electronics product before using it in a particular application.

"Standard": Computers, office equipment, communications equipment, test and measurement equipment, audio and visual equipment, home electronic appliances, machine tools, personal electronic equipment and industrial robots.

"Special": Transportation equipment (automobiles, trains, ships, etc.), traffic control systems, anti-disaster systems, anti-crime systems, safety equipment and medical equipment (not specifically designed for life support).

"Specific": Aircraft, aerospace equipment, submersible repeaters, nuclear reactor control systems, life support systems and medical equipment for life support, etc.

The quality grade of NEC Electronics products is "Standard" unless otherwise expressly specified in NEC Electronics data sheets or data books, etc. If customers wish to use NEC Electronics products in applications not intended by NEC Electronics, they must contact an NEC Electronics sales representative in advance to determine NEC Electronics' willingness to support a given application.

(Note)

- (1) "NEC Electronics" as used in this statement means NEC Electronics Corporation and also includes its majority-owned subsidiaries.
- (2) "NEC Electronics products" means any product developed or manufactured by or for NEC Electronics (as defined above).