

LOW POWER QUAD OPERATIONAL AMPLIFIERS**AZ324****General Description**

The AZ324 consists of four independent, high gain and internally frequency compensated operational amplifiers. It is specifically designed to operate from a single power supply. Operation from split power supply is also possible and the low power supply current drain is independent of the magnitude of the power supply voltages.

The AZ324 series are compatible with industry standard 324.

The AZ324 series are available in 2 Packages: DIP-14 and SOIC-14.

Features

- Internally Frequency Compensated for Unity Gain
- Large Voltage Gain: 100dB (Typical)
- Low Input Bias Current: 20nA (Typical)
- Low Input Offset Voltage: 2mV (Typical)
- Low Supply Current: 0.5mA (Typical)
- Wide Power Supply Voltage Range:
 - Single Supply: 3V to 18V
 - Dual Supplies: $\pm 1.5V$ to $\pm 9V$
- Input Common Mode Voltage Range Includes Ground
- Large Output Voltage Swing: 0V to $V_{CC}-1.5V$
- Power Drain Suitable for Battery Operation

Applications

- Battery Charger
- Cordless Telephone
- Switching Power Supply

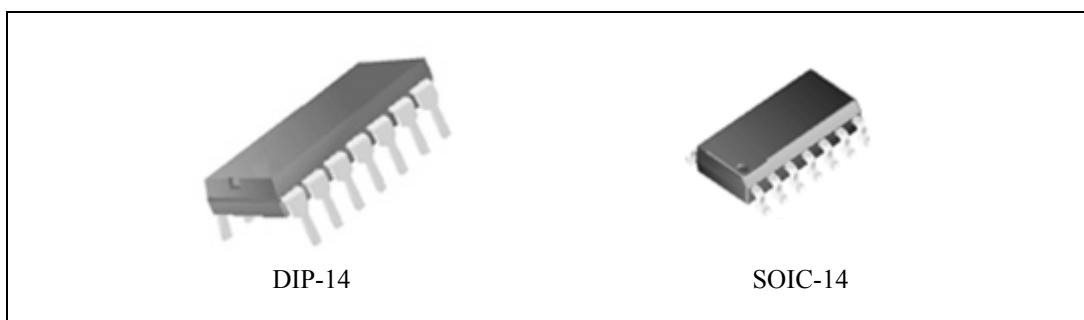

Figure 1. Package Types of AZ324

LOW POWER QUAD OPERATIONAL AMPLIFIERS

AZ324

Pin Configuration

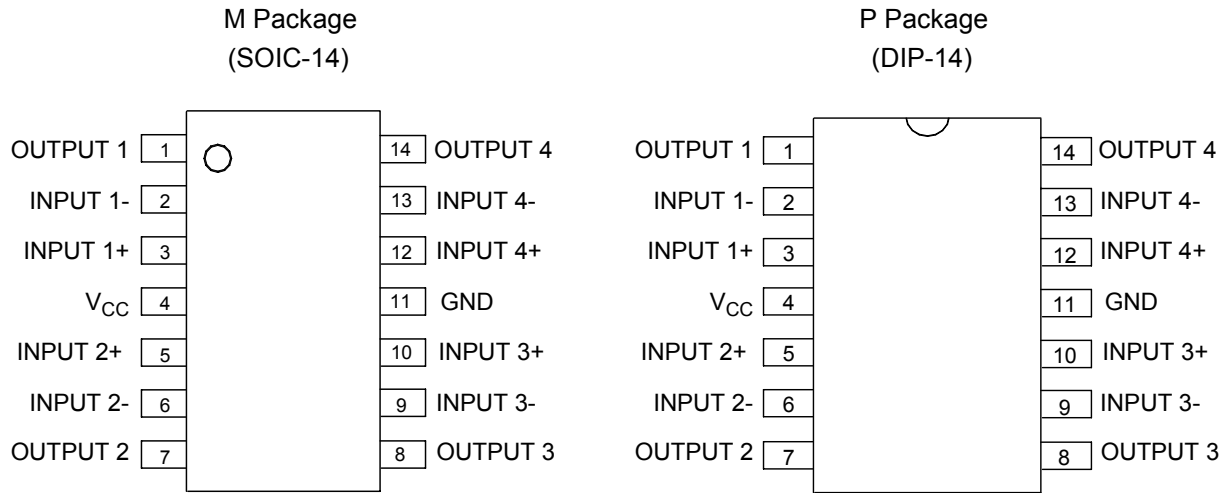

Figure 2. Pin Configuration of AZ324 (Top View)

Functional Block Diagram

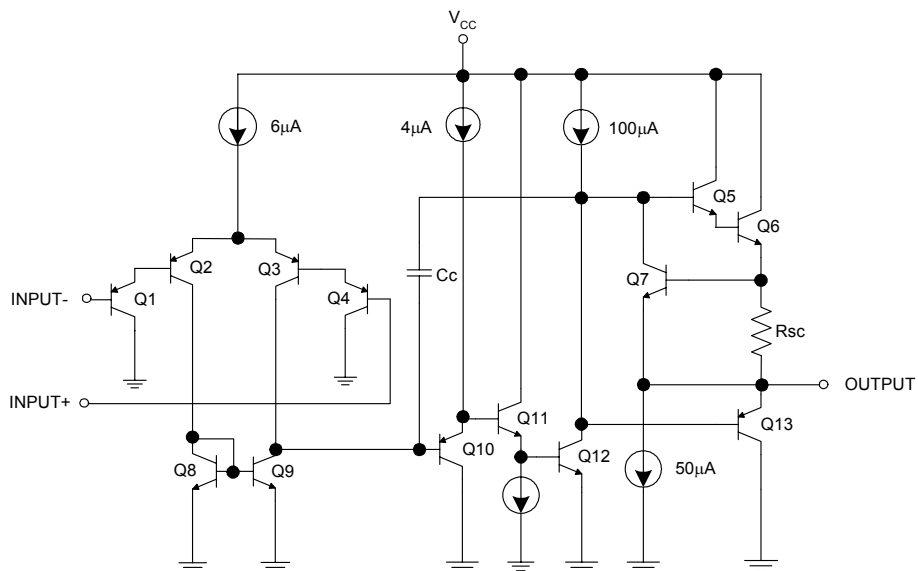

Figure 3. Functional Block Diagram of AZ324
(Each Amplifier)



LOW POWER QUAD OPERATIONAL AMPLIFIERS

AZ324

Ordering Information

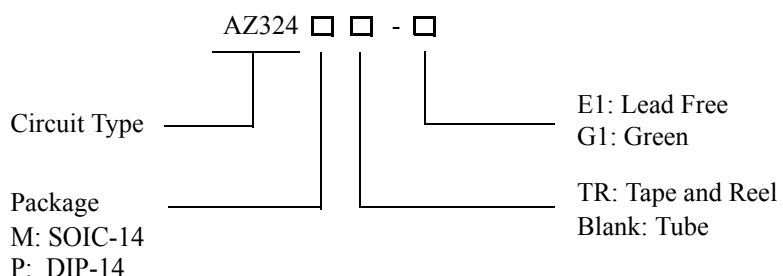

Package	Temperature Range	Part Number		Marking ID		Packing Type
		Lead Free	Green	Lead Free	Green	
SOIC-14	-40 to 85 °C	AZ324M-E1	AZ324M-G1	AZ324M-E1	AZ324M-G1	Tube
		AZ324MTR-E1	AZ324MTR-G1	AZ324M-E1	AZ324M-G1	Tape & Reel
DIP-14	-40 to 85 °C	AZ324P-E1	AZ324P-G1	AZ324P-E1	AZ324P-G1	Tube

BCD Semiconductor's Pb-free products, as designated with "E1" suffix in the part number, are RoHS compliant. Products with "G1" suffix are available in green packages.

**LOW POWER QUAD OPERATIONAL AMPLIFIERS****AZ324****Absolute Maximum Ratings (Note 1)**

Parameter	Symbol	Value		Unit
Power Supply Voltage	V_{CC}	20		V
Differential Input Voltage	V_{ID}	20		V
Input Voltage	V_{IC}	-0.3 to 20		V
Input Current ($V_{IN} < -0.3V$) (Note 2)		50		mA
Output Short Circuit to Ground (One Amplifier) $V_{CC} \leq 12V$ and $T_A = 25^\circ C$ (Note 3)		Continuous		
Power Dissipation ($T_A = 25^\circ C$)	P_D	DIP-14	1130	mW
		SOIC-14	800	
Operating Junction Temperature	T_J	150		$^\circ C$
Storage Temperature Range	T_{STG}	-65 to 150		$^\circ C$
Lead Temperature (Soldering, 10 Seconds)	T_{LEAD}	260		$^\circ C$

Note 1: Stresses greater than those listed under "Absolute Maximum Ratings" may cause permanent damage to the device. These are stress ratings only, and functional operation of the device under these conditions is not implied. Exposure to "Absolute Maximum Ratings" for extended periods may affect device reliability.

Note 2: This input current will only exist when the voltage at any of the input leads is driven negative. It is due to the collector-base junction of the input PNP transistors becoming forward biased and thereby acting as input diode clamps. In addition to this diode action, there is also lateral NPN parasitic transistor action on the IC chip. This transistor action can cause the output voltages of the op amps to go to the V_{CC} voltage level (or to ground for a large overdrive) for the time duration that an input is driven negative. This is not destructive and normal output states will re-establish when the input voltage, which was negative, again returns to a value greater than -0.3V (at $25^\circ C$)

Note 3: Short circuits from the output to V_{CC} can cause excessive heating and eventual destruction. When considering short circuits to ground, the maximum output current is approximately 40mA independent of the magnitude of V_{CC} . At values of supply voltage in excess of +12V, continuous short circuits can exceed the power dissipation ratings and cause eventual destruction. Destructive dissipation can result from simultaneous shorts on all amplifiers.

Recommended Operating Conditions

Parameter	Symbol	Min	Max	Unit
Supply Voltage	V_{CC}	3	18	V
Ambient Operating Temperature Range	T_A	-40	85	$^\circ C$



LOW POWER QUAD OPERATIONAL AMPLIFIERS **AZ324**

Electrical Characteristics

Operating Conditions: $V_{CC}=5V$, $GND=0V$, $T_A=25\text{ }^\circ\text{C}$ unless otherwise specified.

Parameter	Symbol	Test Conditions	Min	Typ	Max	Unit	
Input Offset Voltage	V_{IO}	$V_O=1.4V$, $R_S=0\Omega$, $V_{CC}=5V$ to $15V$		2	5	mV	
Input Bias Current (Note 4)	I_{BIAS}	I_{IN+} or I_{IN-} , $V_{CM}=0V$		20	200	nA	
Input Offset Current	I_{IO}	$I_{IN+} - I_{IN-}$, $V_{CM}=0V$		5	50	nA	
Input Common Mode Voltage Range (Note 5)	V_{IR}	$V_{CC}=15V$	0		$V_{CC}-1.5$	V	
Supply Current	I_{CC}	$R_L=\infty$, Over full temperature range on all OP Amps	$V_{CC}=15V$	1	2	mA	
			$V_{CC}=5V$	0.5	1.2		
Large Signal Voltage Gain	G_V	$V_{CC}=15V$, $R_L \geq 2k\Omega$, $V_O=1V$ to $11V$	85	100		dB	
Common Mode Rejection Ratio	CMRR	DC, $V_{CC}=15V$, $V_{CM}=0V$ to $(V_{CC}-1.5)V$	65	85		dB	
Power Supply Rejection Ratio	PSRR	$V_{CC}=5V$ to $15V$	70	90		dB	
Channel Separation (Note 6)	CS	$f=1kHz$ to $20kHz$ (Input Referred)		-120		dB	
Output Current	Source	I_{SOURCE}	$V_{IN+}=1V$, $V_{IN-}=0V$, $V_{CC}=15V$, $V_O=2V$	20	45		mA
	Sink	I_{SINK}	$V_{IN+}=0V$, $V_{IN-}=1V$, $V_{CC}=15V$, $V_O=2V$	10	20		mA
			$V_{IN+}=0V$, $V_{IN-}=1V$, $V_{CC}=15V$, $V_O=0.2V$	12	50		μA
Output Short Circuit to Ground	I_{SC}	$V_{CC}=15V$		45	60	mA	
Output Voltage Swing	V_{OH}	$V_{CC}=15V$, $R_L=2k\Omega$	12			V	
		$V_{CC}=15V$, $R_L=10k\Omega$	12.5	13.5			
	V_{OL}	$V_{CC}=5V$, $R_L=10k\Omega$		5	20	mV	
Thermal Resistance (Junction to Case)	θ_{JC}	DIP-14		31.79		$^\circ\text{C/W}$	
		SOIC-14		47.18			

Note 4: The direction of the input current is out of the IC due to the PNP input stage. This current is essentially constant, independent of the state of the output so no loading change exists on the input lines.

Note 5: The input common-mode voltage of either input signal voltage should not be allowed to go negatively by more than 0.3V (at 25°C). The upper end of the common-mode voltage range is $V_{CC}-1.5V$ (at 25°C), but either or both inputs can go to +18V without damages, independent of the magnitude of the V_{CC} .

Note 6: Due to proximity of external components, insure that coupling is not originating via stray capacitors between these external parts. This typically can be detected as this type of capacitance increases at higher frequencies.



LOW POWER QUAD OPERATIONAL AMPLIFIERS

AZ324

Typical Performance Characteristics

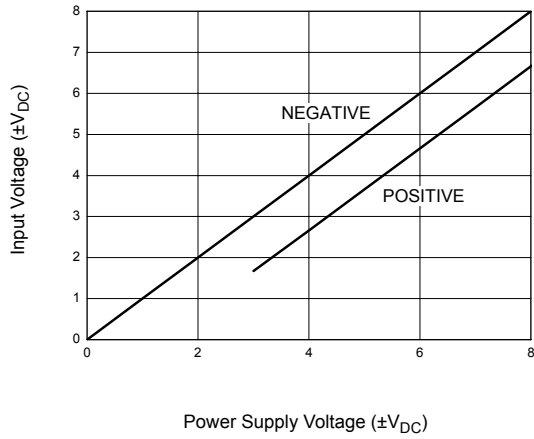

Figure 4. Input Voltage Range

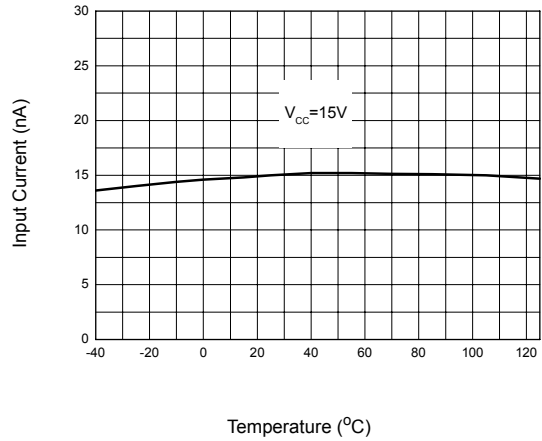

Figure 5. Input Current

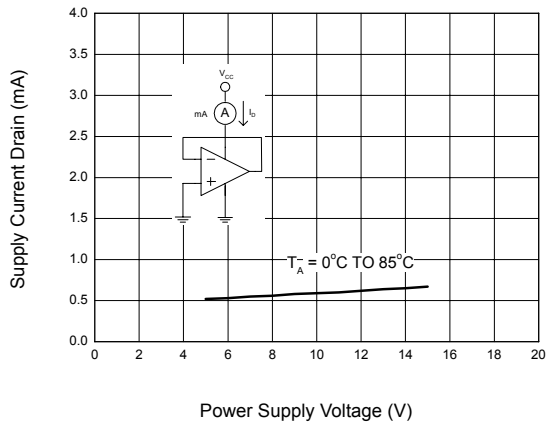

Figure 6. Supply Current

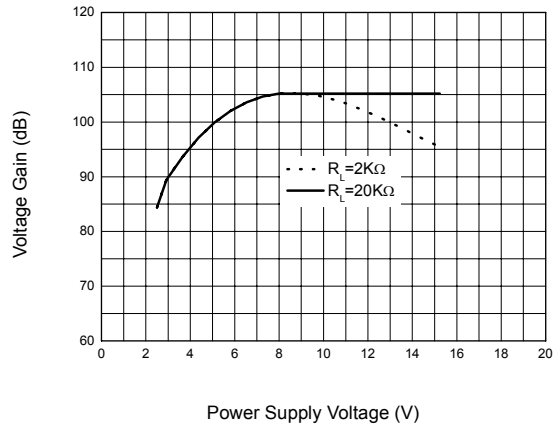

Figure 7. Voltage Gain

LOW POWER QUAD OPERATIONAL AMPLIFIERS

AZ324

Typical Performance Characteristics (Continued)

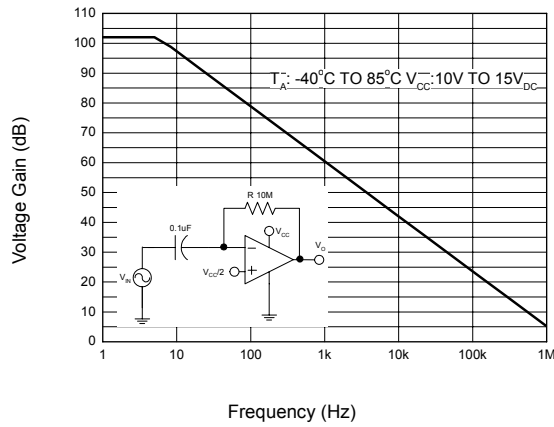

Figure 8. Open Loop Frequency Response

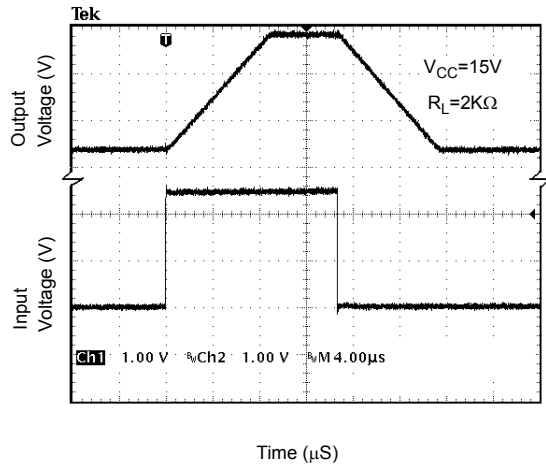

Figure 9. Voltage Follower Pulse Response

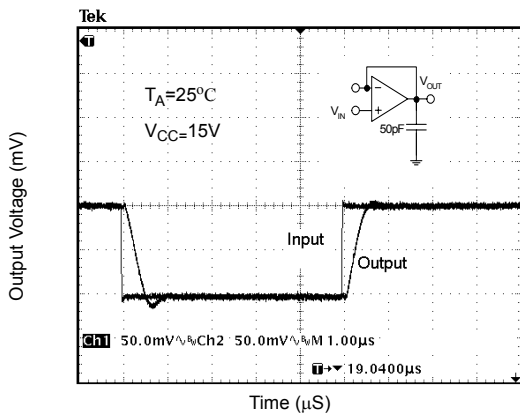

Figure 10. Voltage Follower Pulse Response (Small Signal)

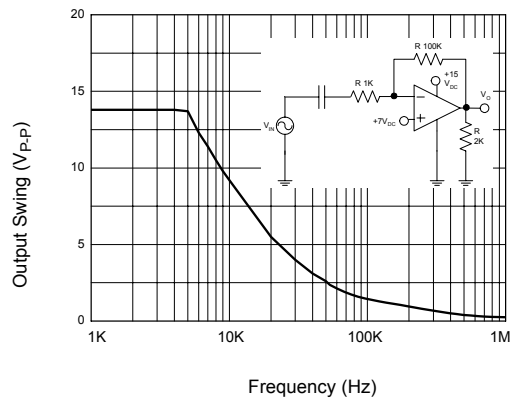

Figure 11. Large Signal Frequency Response

Typical Performance Characteristics (Continued)

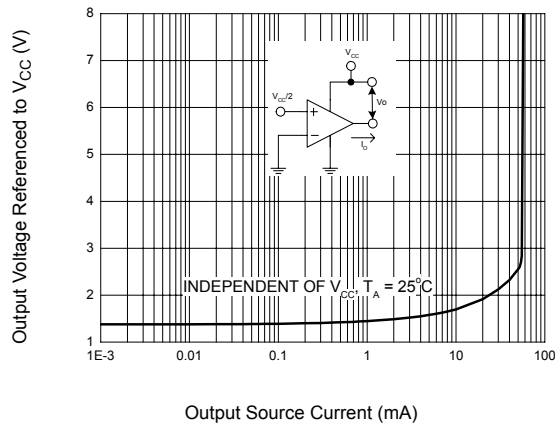

Figure 12. Output Characteristics Current Sourcing

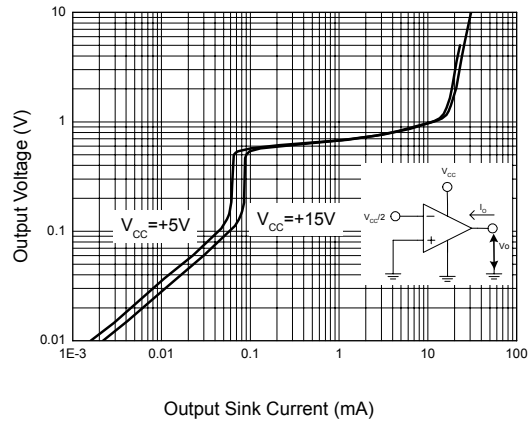

Figure 13. Output Characteristics Current Sinking

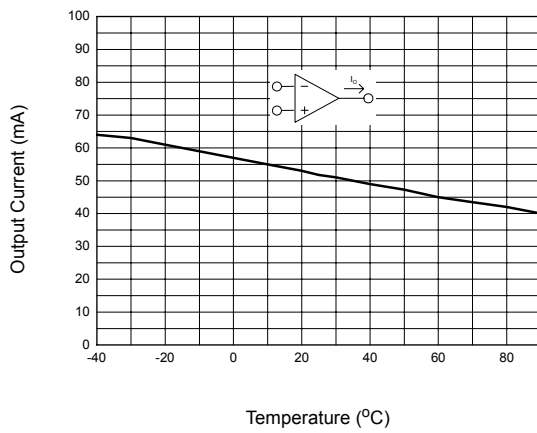

Figure 14. Current Limiting

Typical Applications

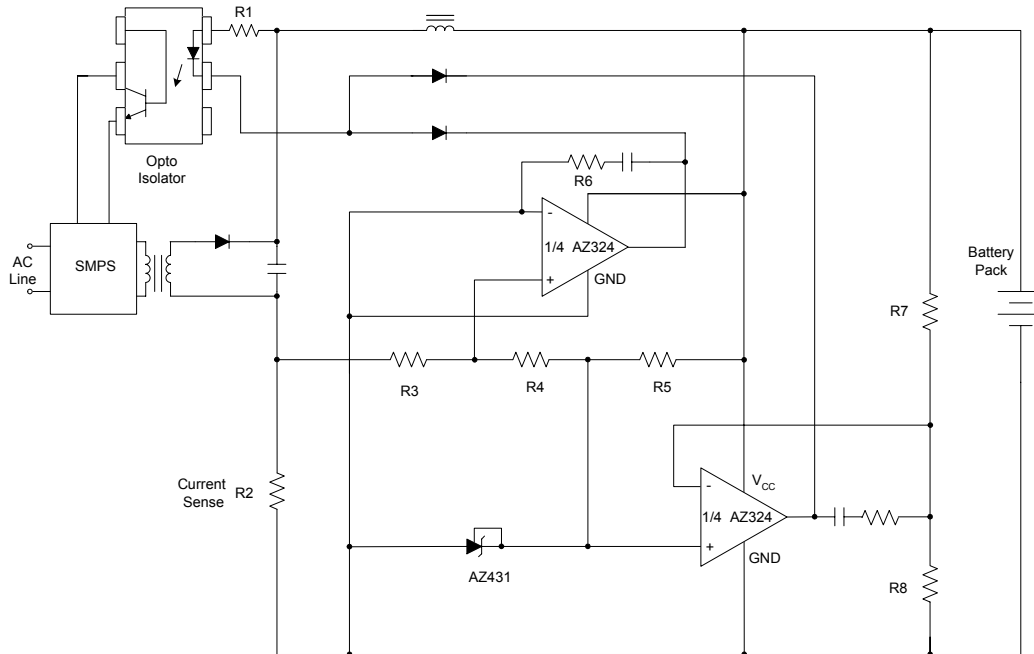

Figure 15. Battery Charger

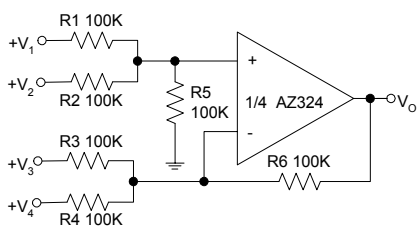

Figure 16. DC Summing Amplifier

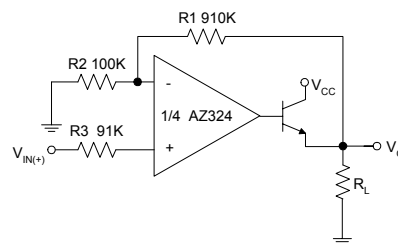

Figure 17. Power Amplifier

Typical Applications (Continued)

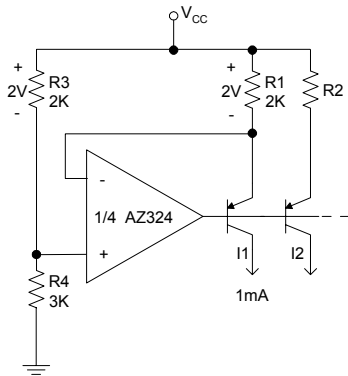

Figure 18. Fixed Current Sources

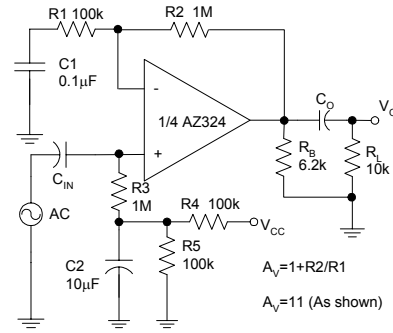

Figure 19. AC Coupled Non-Inverting Amplifier

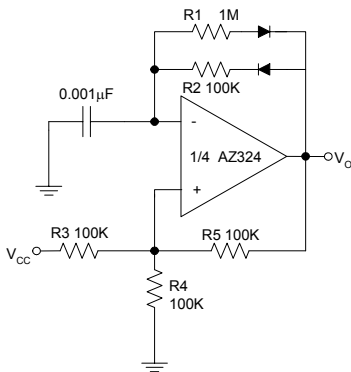

Figure 20. Pulse Generator

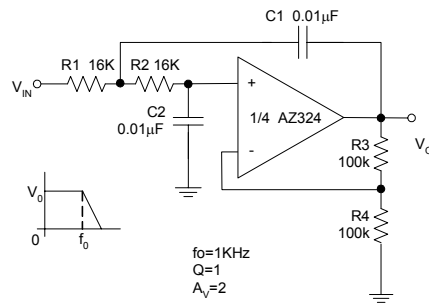

Figure 21. DC Coupled Low-Pass RC Active Filter



LOW POWER QUAD OPERATIONAL AMPLIFIERS

AZ324

Mechanical Dimensions

DIP-14

Unit: mm(inch)

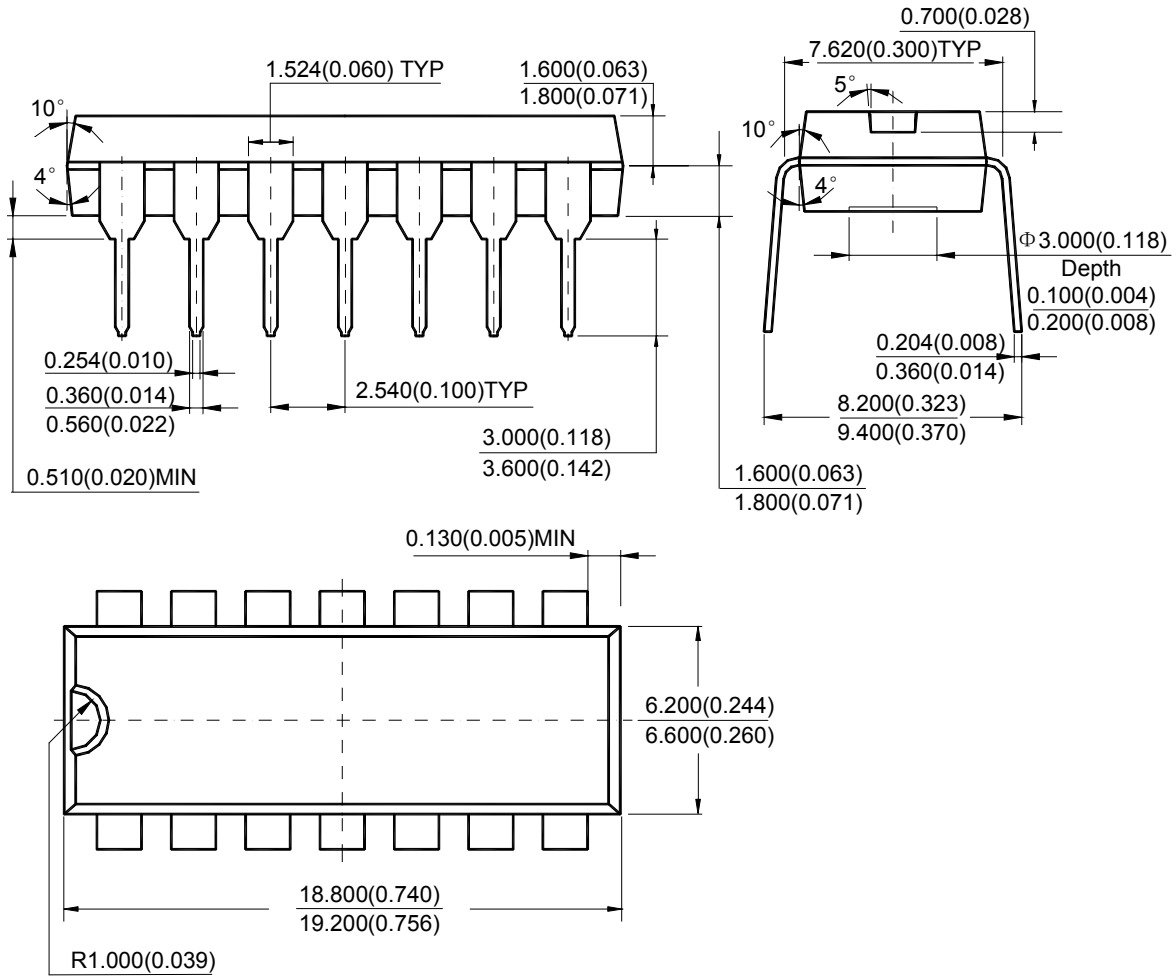

Note: Eject hole, oriented hole and mold mark is optional.



LOW POWER QUAD OPERATIONAL AMPLIFIERS

AZ324

Mechanical Dimensions (Continued)

SOIC-14

Unit: mm(inch)

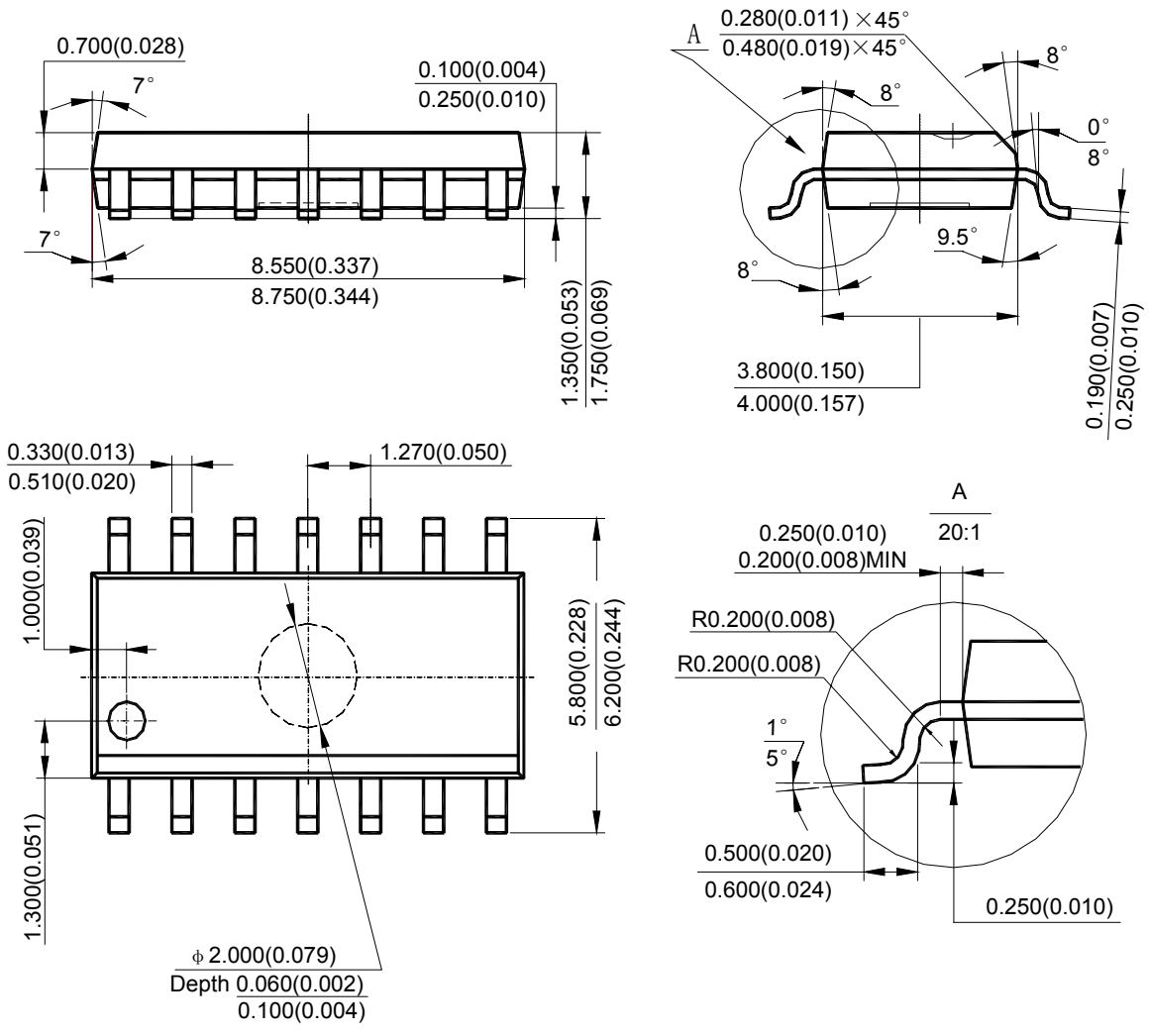

Note: Eject hole, oriented hole and mold mark is optional.



BCD Semiconductor Manufacturing Limited

<http://www.bcdsemi.com>

IMPORTANT NOTICE

BCD Semiconductor Manufacturing Limited reserves the right to make changes without further notice to any products or specifications herein. BCD Semiconductor Manufacturing Limited does not assume any responsibility for use of any its products for any particular purpose, nor does BCD Semiconductor Manufacturing Limited assume any liability arising out of the application or use of any its products or circuits. BCD Semiconductor Manufacturing Limited does not convey any license under its patent rights or other rights nor the rights of others.

MAIN SITE

- Headquarters

BCD Semiconductor Manufacturing Limited

No. 1600, Zi Xing Road, Shanghai Zizhu Science-based Industrial Park, 200241, China
Tel: +86-21-24162266, Fax: +86-21-24162277

- Wafer Fab

Shanghai SIM-BCD Semiconductor Manufacturing Co., Ltd.

800 Yi Shan Road, Shanghai 200233, China
Tel: +86-21-6485 1491, Fax: +86-21-5450 0008

REGIONAL SALES OFFICE

Shenzhen Office

Shanghai SIM-BCD Semiconductor Manufacturing Co., Ltd., Shenzhen Office

Unit A Room 1203, Skyworth Bldg., Gaoxin Ave. 1.S., Nanshan District, Shenzhen, China
Tel: +86-755-8826 7951
Fax: +86-755-8826 7865

Taiwan Office

BCD Semiconductor (Taiwan) Company Limited

4F, 298-1, Rui Guang Road, Nei-Hu District, Taipei, Taiwan
Tel: +886-2-2656 2808
Fax: +886-2-2656 2806

USA Office

BCD Semiconductor Corp.

30920 Huntwood Ave. Hayward, CA 94544, USA
Tel : +1-510-324-2988
Fax: +1-510-324-2788