



# SERIES N

## COAXIAL CONNECTORS 50 Ω

### Description

SUHNER N connectors are available with 50 Ω and 75 Ω impedance. The frequency range extends to 18 GHz, depending on the connector and cable type. The screw-type coupling mechanism provides a sturdy and reliable connection.

SUHNER N connectors are available for flexible cables, for semi-rigid cables and for corrugated copper tube cables.

Cable entries: clamp, crimp and solder types available, as well as SUHNER QUICK-FIT for corrugated copper tube cables.

### Compatibility

Inner conductors of N 75 Ω connectors have a smaller diameter than those of the 50 Ω version. Therefore 50 Ω and 75 Ω connectors must not be mated with each other.

### Contents

Description .....	295
Interface Dimensions .....	295
Interface Dimensions in mm / inches .....	295
Standards .....	295
Technical Data .....	296
Connectors for Semi-Rigid Cables .....	299
Connectors for Foam Dielectric Corrugated Copper Tube Cables .....	303
Connectors for Flexible Cables .....	308
Receptacles with Solder End .....	320
Receptacles for Microwave Components ...	321
Stripline Launchers .....	323
Adaptors Within-Series .....	324
Protective Caps .....	328
Terminations .....	329

Page

### Interface Dimensions

### Interface Dimensions in mm / inches

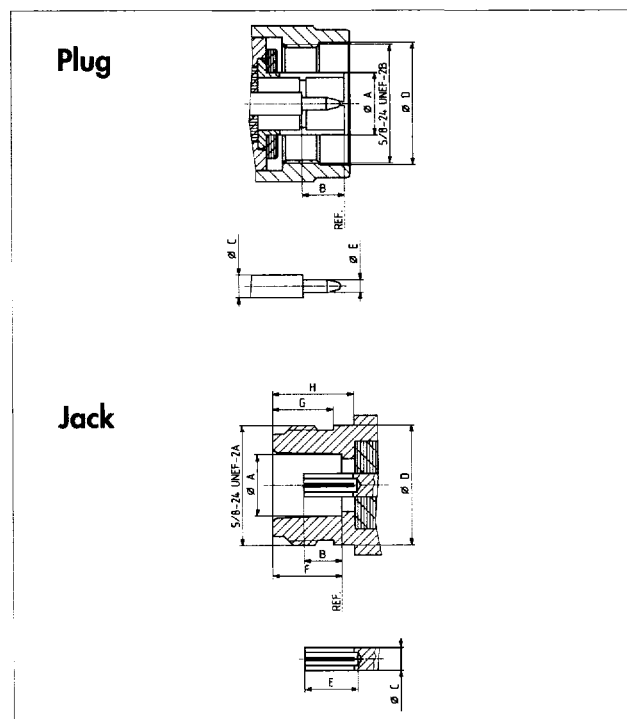

	Plug		Jack	
	min.	max.	min.	max.
A	—	8.38/.330	8.03/.316	8.13/.320
B	5.33/.210	5.84/.230	4.75/.187	5.26/.207
C	—	3.15/.124	—	3.15/.124
D	16.00/.630	—	—	15.93/.627
E	1.60/.063	1.68/.066	5.33/.210	—
F	—	—	9.04/.356	9.19/.362
G	—	—	6.76/.266	—
H	—	—	10.72/.422	—

### Standards

Interface dimensions conform to:  
**IEC 169-16,**  
**CECC 22 210**  
**MIL-STD-348A/304**

Z

## Technical Data

ELECTRICAL DATA	REQUIREMENTS
Impedance	50 $\Omega$
Frequency range – flexible cables – semi-rigid cables	DC ... 11 GHz (see also Appendix page 436) DC ... 18 GHz (see also Appendix page 436)
VSWR	see table below
PIM <sup>1)</sup>	$\geq 155$ dBc for SUHNER QUICK-FIT <sup>®</sup>
Insertion loss	see Appendix page 437
RF-leakage (between 2 ÷ 3 GHz)	$\geq 90$ dB
Dielectric withstanding voltage (at sea level)	2.5 kV rms, 50 Hz
Working voltage (at sea level)	$\leq 1.0$ kV rms, 50 Hz
Insulation resistance	$\geq 5 \cdot 10^3$ M $\Omega$
Contact resistance – centre contact – outer contact	$\leq 1.0$ m $\Omega$ $\leq 1.0$ m $\Omega$

1) Carrier to 3rd order intermodulation product ratio with  $2 \times 25$  W carrier power,  $f \leq 1.88$  GHz

TYPICAL VSWR	FREQUENCY RANGE					CABLE GROUP
	1 GHz	2.5 GHz	5 GHz	12.4 GHz	18 GHz	
straight connectors	1.04	1.05	1.08	1.30		Y3, Y11
	1.04	1.05	1.05	1.12		Y5, Y12
	1.04	1.05	1.05	1.08	1.09	Y5, Y12 #
	1.04	1.05	1.06	1.09	1.12	Y7
	1.04	1.07				M9 – M42
	1.05	1.09	1.17			U7, U9
right angle connectors	1.04	1.05	1.12			U28 – U33
	1.05	1.10	1.22			U7, U9
	1.08	1.10	1.14			U28 – U33

Other connectors and cables on request

# = precision type

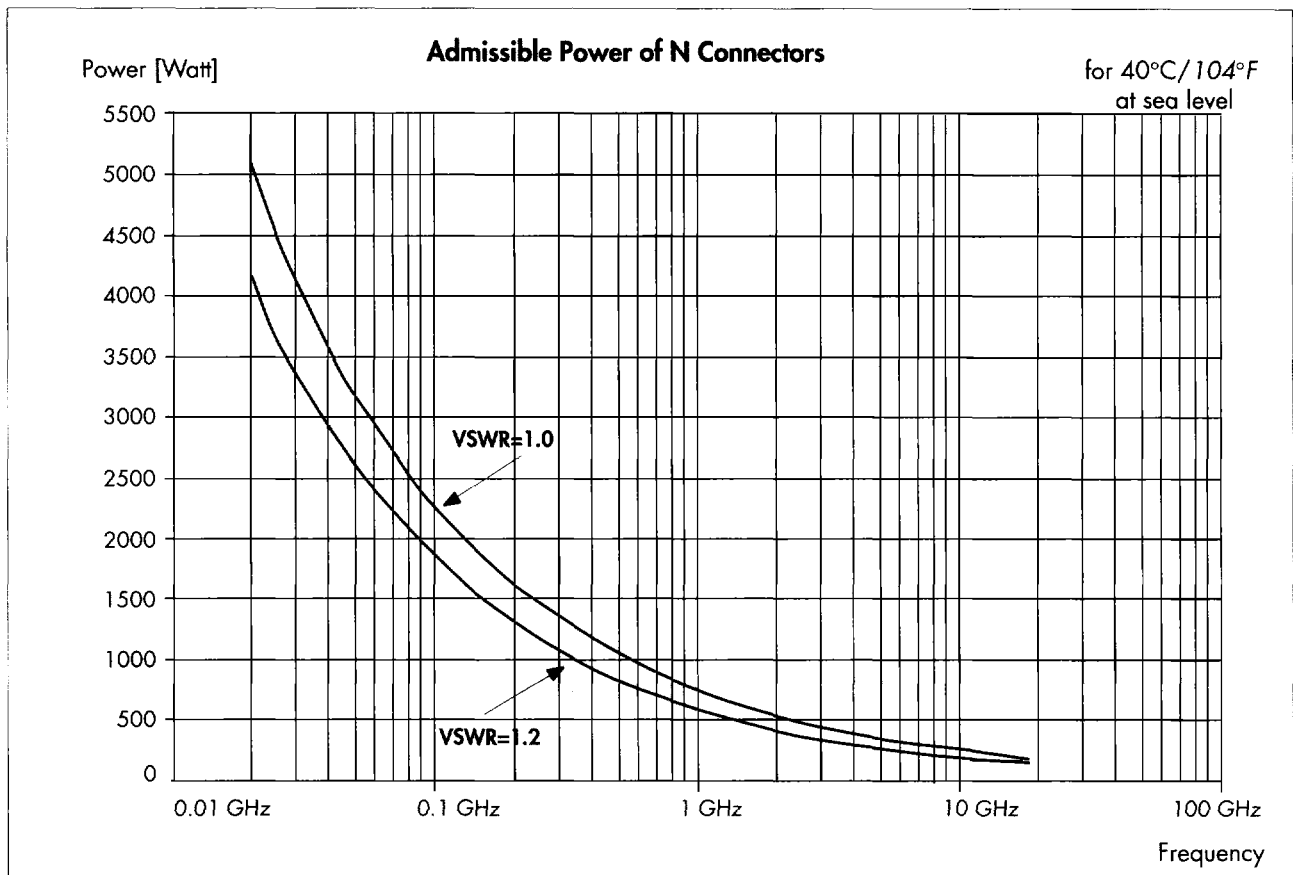

For detailed information regarding power measurement, please refer to page 437.

MECHANICAL DATA	REQUIREMENTS
Coupling nut torque – recommended – proof torque	0.68 Nm ... 1.13 Nm / 6.0 ... 10.0 in.-lbs 1.70 Nm / 15.0 in.-lbs
Couling nut retention force	≥ 450 N / 101.2 lbs
Contact captivation	≥ 28 N / 6.3 lbs
Cable retention force <sup>1)</sup>	see pages 36 – 41
Durability (matings)	≥ 500

1) value considers maximum load of the cables without irreversible variations of specifications.

ENVIRONMENTAL DATA	TEST CONDITIONS
Temperature range SUHNER QUICK-FIT®	- 65°C ... + 165°C / - 85°F ... + 329°F - 40°C ... + 85°C / - 40°F ... + 185°F
Climatic category acc. to IEC	55 / 155 / 21
Thermal shock	MIL-STD-202, Method 107, Condition B
Moisture resistance	MIL-STD-202, Method 106
Corrosion	Saltspray test acc. to MIL-STD-202, Method 101, Condition B
Vibration	MIL-STD-202, Method 204, Condition B
Shock	MIL-STD-202, Method 213, Condition I
SUHNER QUICK-FIT®, degree of protection (humidity)	IP 67 → IEC 529

MATERIAL DATA			
CONNECTOR PART	STANDARDS	MATERIAL	PLATING
Bodies Pin contact	QQ-B-626	brass	SUCOPLATE® gold plated
Outer contact, slotted	DIN 17660	spring bronze	SUCOPLATE®
Female contacts	QQ-C-530	beryllium-copper, hardened	gold plated
Crimp ferrules	SUHNER® specification	copper	SUCOPLATE®
Insulators, standard version	ASTM-D-1457, BS 4271 Grade B	PTFE	
Gaskets	ASTM-E-1418 PS 1	silicone rubber	

Some connectors may have a specification that differs from the above mentioned data.

# Connectors for Semi-Rigid Cables

## straight plugs

- > cable entry soldered
- > centre contact soldered

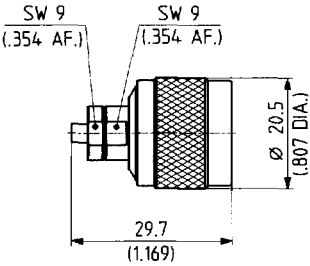

Fig. 1

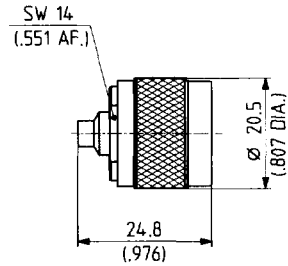
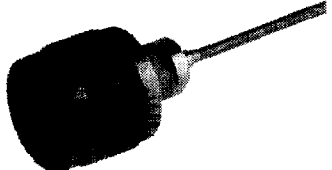

Fig. 2



SUHNER TYPE	Ident. no.	Cable group (example)	Assembly instruction	Frequency range	Weight	Fig.	Notes
11 N-50-2-14	642513	Y3, Y11 (EZ 86)	9130	DC-18 GHz	30.0 g/1.05 oz.	1	
11 N-50-3-13	542083	Y5, Y11 (EZ 141)	3095	DC-12.4 GHz	29.0 g/1.02 oz.	2	

- > cable entry soldered (fig. 1)
- > cable entry clamp (fig. 2)
- > plug-in centre contact

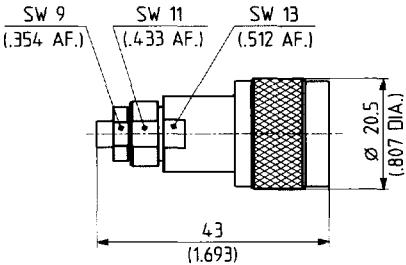

Fig. 1

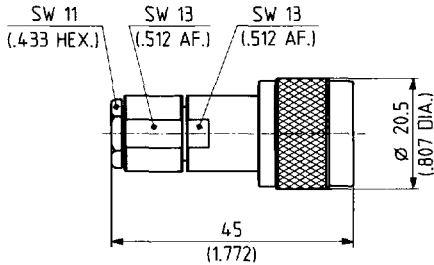
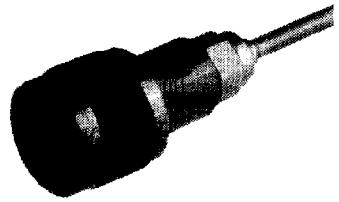

Fig. 2



SUHNER TYPE	Ident. no.	Cable group (example)	Assembly instruction	Frequency range	Weight	Fig.	Notes
11 N-50-3-51	• 543919	Y5, Y12 (EZ 141)	9006	DC-18 GHz	43.0 g/1.51 oz.	1	stainless steel
11 N-50-5-39	• 642481	Y7 (EZ 250)	9089	DC-18 GHz	51.0 g/1.79 oz.	2	
11 N-50-5-52	• 641530	Y7 (EZ 250)	9089	DC-18 GHz	51.0 g/1.79 oz.	2	stainless steel

- centre contact captivated

## straight jacks

- > cable entry soldered
- > centre contact soldered

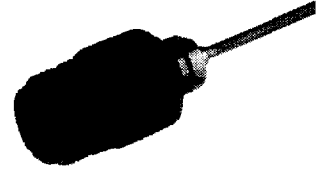
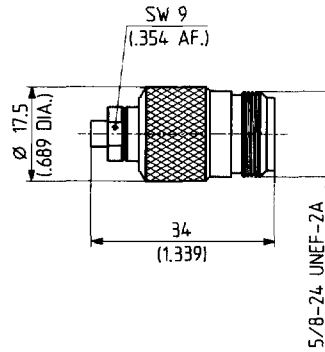

SUHNER TYPE	Ident. no.	Cable group (example)	Assembly instruction	Frequency range	Weight	Notes
21 N-50-2-14	642666	Y3, Y11 (EZ 86)	9073	DC-18 GHz	38.0 g/1.33 oz.	
21 N-50-3-11	543921	Y5, Y12 (EZ 141)	9005	DC-12.4 GHz	38.0 g/1.33 oz.	

- > cable entry soldered (fig. 1)
- > cable entry clamp (fig. 2)
- > plug-in centre contact

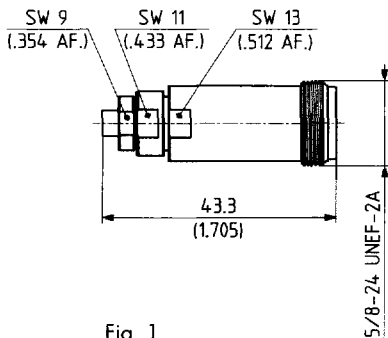

Fig. 1

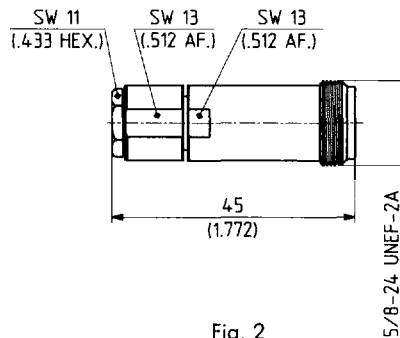
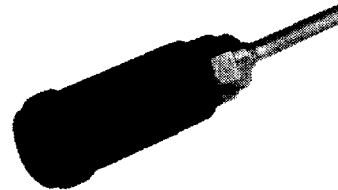

Fig. 2



SUHNER TYPE	Ident. no.	Cable group (example)	Assembly instruction	Frequency range	Weight	Fig.	Notes
21 N-50-3-51	• 543922	Y5, Y12 (EZ 141)	9006	DC-18 GHz	36.0 g/1.26 oz.	1	stainless steel
21 N-50-5-52	• 641531	Y7 (EZ 250)	9089	DC-18 GHz	39.0 g/1.37 oz.	2	stainless steel

- centre contact captivated

## bulkhead jacks

- > cable entry soldered
- > centre contact soldered
- > with panel seal
- > suitable for insulated mounting
- > insulating washers see page 425

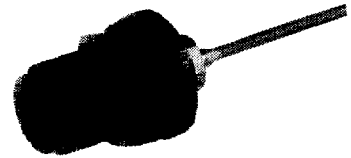
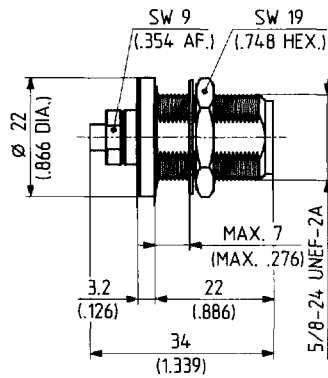

SUHNER TYPE	Ident. no.	Cable group (example)	Mounting hole	Assembly instruction	Frequency range	Weight	Notes
24 N-50-2-14	544637	Y3, Y11 (EZ 86)	ML 12	9073	DC-18GHz	39.0 g/1.37 oz.	
24 N-50-3-14	542300	Y5, Y12 (EZ 141)	ML 12	9005	DC-12.4GHz	39.0 g/1.37 oz.	

- > cable entry soldered
- > with panel seal
- > suitable for insulated mounting
- > insulating washers see page 425

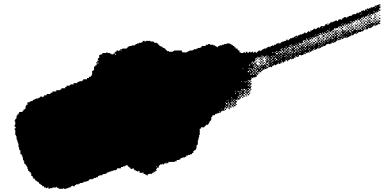
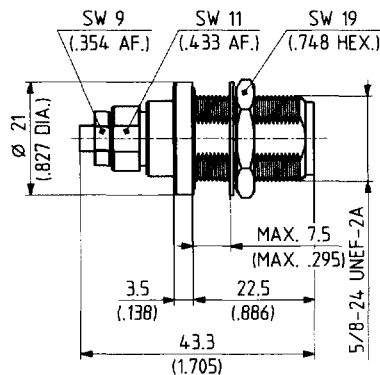

SUHNER TYPE	Ident. no.	Cable group (example)	Mounting hole	Assembly instruction	Frequency range	Weight	Notes
24 N-50-3-51	642344	Y5, Y12 (EZ 141)	ML 12	9006	DC-18GHz	45.0 g/1.58 oz.	

stainless steel

- centre contact captivated

- > cable entry clamp
- > plug-in centre contact
- > with panel seal
- > suitable for insulated mounting
- > insulating washers see page 425

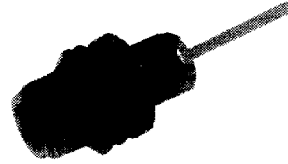
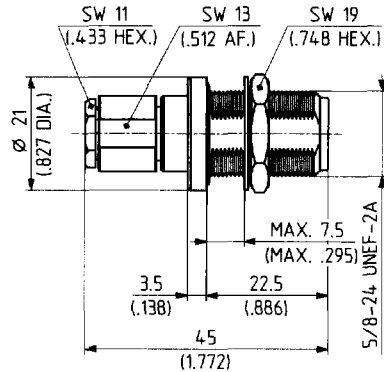

SUHNER TYPE	Ident. no.	Cable group (example)	Mounting hole	Assembly instruction	Frequency range	Weight	Notes
24 N-50-5-39	642505	Y7 (EZ 250)	ML 12	9089	DC-18GHz	53.0 g/1.86 oz.	

## panel jacks

- > cable entry soldered
- > centre contact soldered
- > fastening screws see page 424

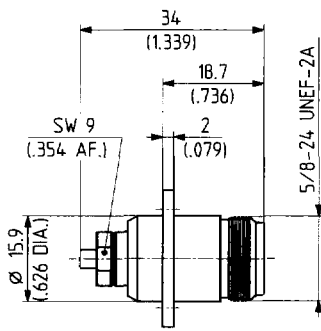
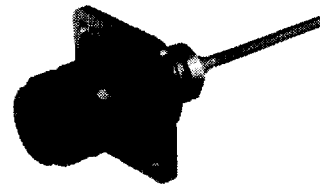

Fig. 1

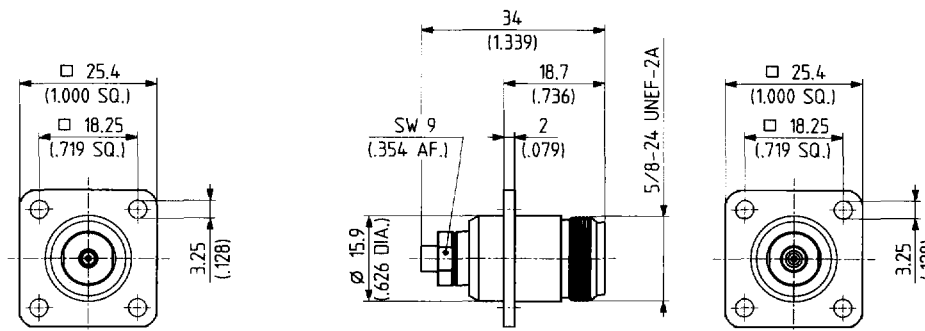

Fig. 2

SUHNER TYPE	Ident. no.	Cable group (example)	Mounting hole	Assembly instruction	Frequency range	Weight	Fig.
25 N-50-2-14	641303	Y3, Y11 (EZ 86)	ML 14	9073	DC-18GHz	42.0 g/1.47 oz.	1
25 N-50-3-9	543952	Y5, Y12 (EZ 141)	ML 14	9005	DC-12.4GHz	42.0 g/1.47 oz.	2

- centre contact captivated



# Connectors for Foam Dielectric Corrugated Copper Tube Cables

SUHNER manufactures a variety of N connectors for use with corrugated copper tube cables of 50 Ω impedance. The cable entries are water and hu-

midity proof, a special sealing compound (plast) is not required.

## straight plugs

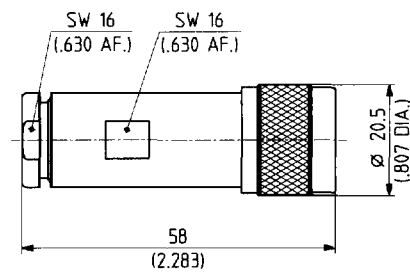

Fig. 1

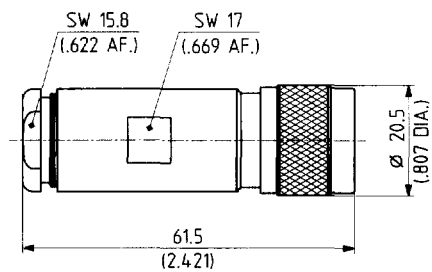
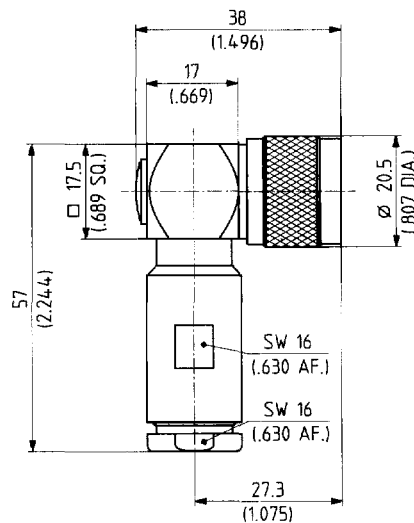

Fig. 2

SUHNER TYPE	Ident. no.	Cable group (example)	Assembly instruction	Flaring tool	Face spanner	Weight	Fig.
11 N-50-6-21	• 652102	M6 (CF1/4"CU2Y)	9050	74 Z-0-0-49	74 Z-0-0-48	73.0 g/2.56 oz.	1
11 N-50-8-21	• 652103	M8 (CF3/8"CU2Y)	9049	74 Z-0-0-47	74 Z-0-0-46	76.0 g/2.66 oz.	2

## right angle plug



SUHNER TYPE	Ident. no.	Cable group (example)	Assembly instruction	Flaring tool	Face spanner	Weight
16 N-50-6-21	• 652104	M6 (CF1/4"CU2Y)	9052	74 Z-0-0-49	74 Z-0-0-48	106.0 g/3.71 oz.

• centre contact captivated

cable groups see pages 36

assembly tools see page 403

mounting holes see page 441

## straight jacks

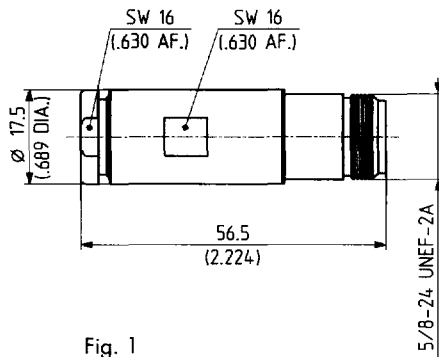

Fig. 1

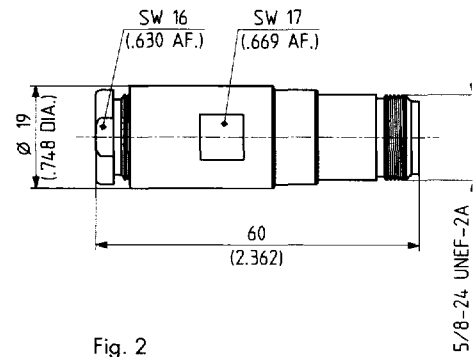
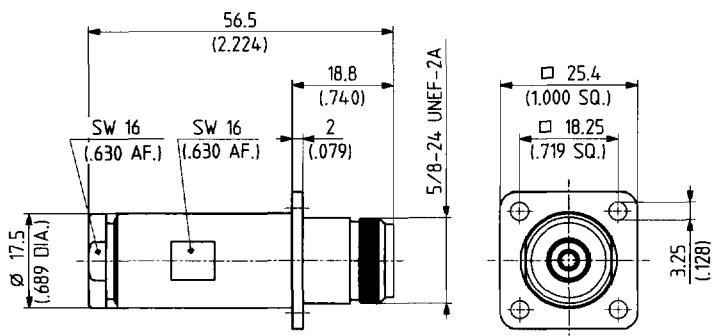

Fig. 2

SUHNER TYPE	Ident. no.	Cable group (example)	Assembly instruction	Flaring tool	Face spanner	Weight	Fig.
21 N-50-6-21	• 652105	M6 (CF1/4"CU2Y)	9050	74 Z-0-0-49	74 Z-0-0-48	67.0 g/2.35 oz.	1
21 N-50-8-21	• 652106	M8 (CF3/8"CU2Y)	9049	74 Z-0-0-47	74 Z-0-0-46	70.0 g/2.45 oz.	2

## panel jacks

> fastening screws see page 424



SUHNER TYPE	Ident. no.	Cable group (example)	Assembly instruction	Flaring tool	Face spanner	Weight
25 N-50-6-21	• 652107	M6 (CF1/4"CU2Y)	9050	74 Z-0-0-49	74 Z-0-0-48	73.0 g/2.56 oz.

mounting hole ML 11

• centre contact captivated

> fastening screws see page 424

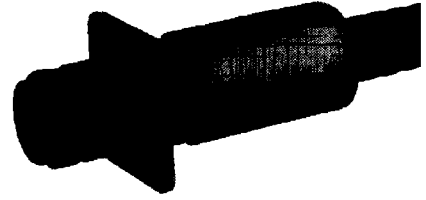
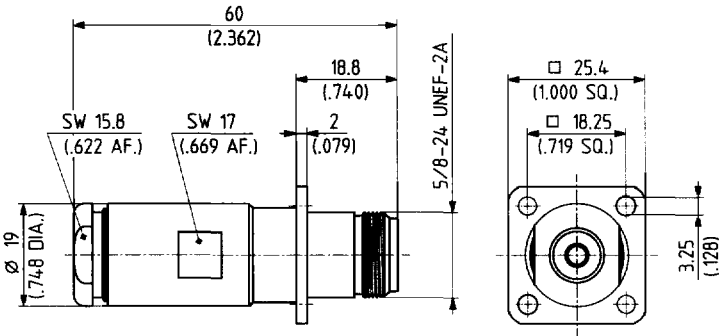

SUHNER TYPE	Ident. no.	Cable group (example)	Assembly instruction	Flaring tool	Face spanner	Weight
25 N-50-8-21	652108	M8 (CF3/8"CU2Y)	9049	74 Z-0-0-47	74 Z-0-0-46	76.0 g/2.66 oz.

mounting hole ML 18

## SUHNER QUICK-FIT® Coaxial Connectors

- low passive intermodulation types
- quick and easy assembly
- degree of protection IP 67
- suitable for outdoor applications

### straight plugs

> assembly tools see page 417

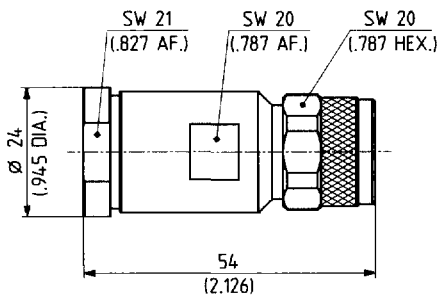

Fig. 1

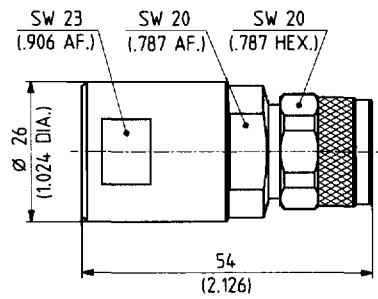

Fig. 2

SUHNER TYPE	Ident. no.	Suitable cables	Assembly instruction	Weight	Fig.
11 N-50-9-8	650043	1/2" Highflex: FSJ4-50B, HCF 1/2" Cu2Y AlCu	9152	100 g/3.50 oz.	1
11 N-50-12-115	651479	1/2": SUCOFEED 1/2", LDF4-50A, LCF 1/2" Cu2Y	9153	100 g/3.50 oz.	2

- centre contact captivated

cable groups see pages 36

assembly tools see page 403

mounting holes see page 441

> assembly tools see page 417

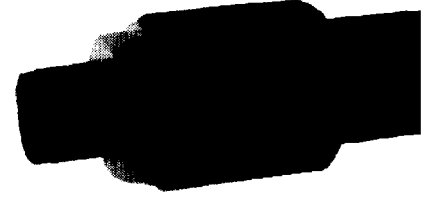
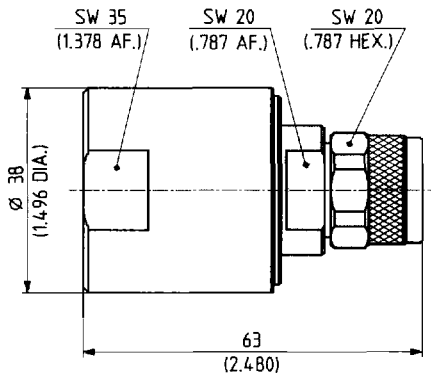

SUHNER TYPE	Ident. no.	Suitable cables	Assembly instruction	Weight
11 N-50-23-101	651427	7/8": SUCOFEED 7/8", LDF5-50A, LCF 7/8" Cu2Y	9154	200 g/7.00 oz.

### straight jacks

> assembly tools see page 417

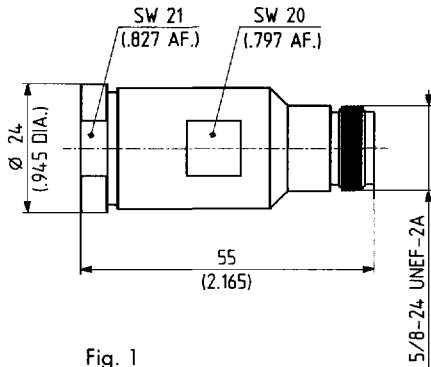

Fig. 1

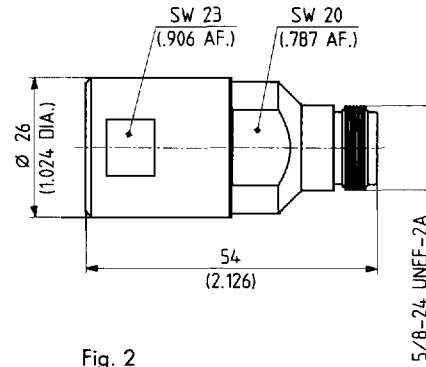
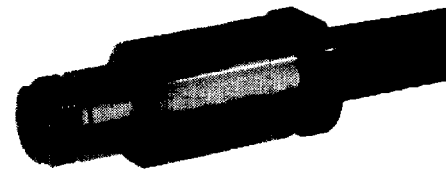
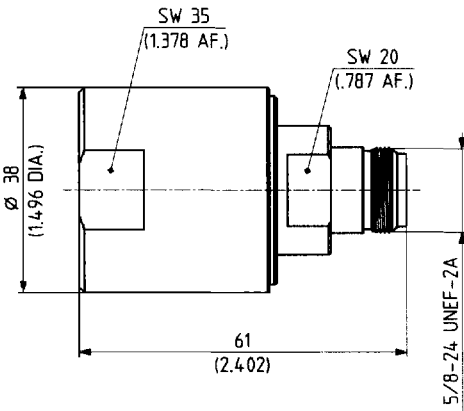

Fig. 2

SUHNER TYPE	Ident. no.	Suitable cables	Assembly instruction	Weight	Fig.
21 N-50-9-2	650044	1/2" Highflex: FSJ4-50B, HCF 1/2" Cu2Y AICu	9152	95 g/3.33 oz.	1
21 N-50-12-101	651480	1/2": SUCOFEED 1/2", LDF4-50A, LCF 1/2" Cu2Y	9153	100 g/.3.50 oz.	2

● centre contact captivated

> assembly tools see page 417



SUHNER TYPE	Ident. no.	Suitable cables	Assembly instruction	Weight
21 N-50-23-101	651428	7/8": SUCOFEED 7/8", LDF5-50A, LCF 7/8" Cu2Y	9154	190 g/6.90 oz.

**panel jack**

> assembly tools see page 417

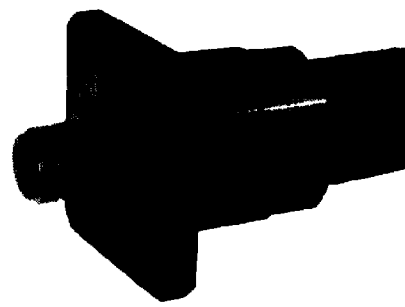
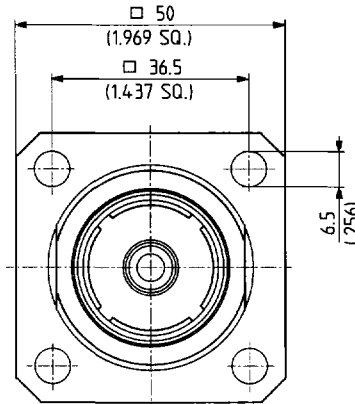
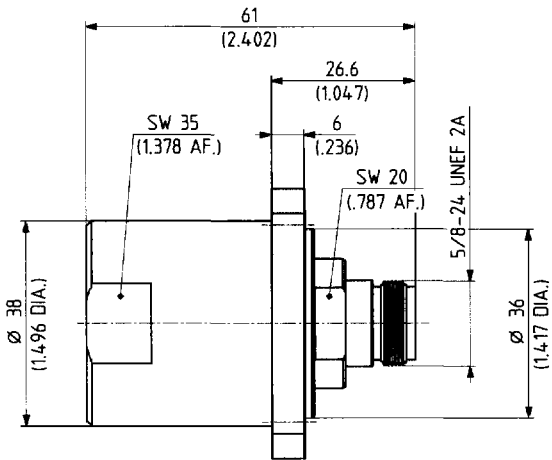

SUHNER TYPE	Ident. no.	Suitable cables	Assembly instruction	Weight
25 N-50-23-101	652109	7/8": SUCOFEED 7/8", LDF5-50A, LCF 7/8" Cu2Y	9154	275 g/9.63 oz.

• centre contact captivated

N 50

# Connectors for Flexible Cables

## straight plugs

- > cable entry clamp
- > centre contact soldered

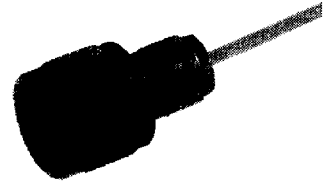
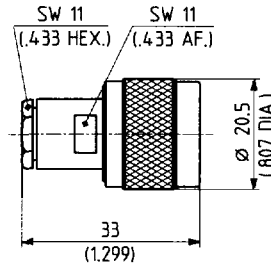

SUHNER TYPE	Ident. no.	Cable group (example)		Assembly instruction	Weight	Notes
11 N-50-2-1	• 544030	U2 (RG 316/U)		3017	38.0 g/1.33 oz.	
11 N-50-2-2	• 643807	U4 (K 02252 D)		3017	38.0 g/1.33 oz.	
11 N-50-2-3	• 542069	U7,10 (RG58C/U)		3016	36.0 g/1.26 oz.	
11 N-50-2-5	• 542073	U7,10 (RG58C/U)		3017	36.0 g/1.26 oz.	

- > cable entry clamp
- > centre contact soldered

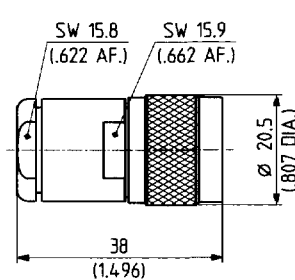

Fig. 1

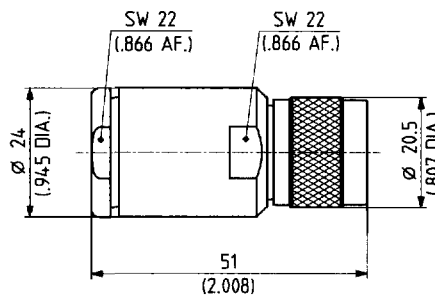
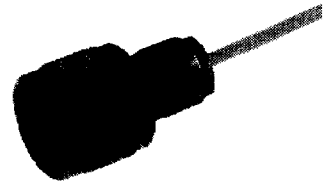

Fig. 2



SUHNER TYPE	Ident. no.	Cable group (example)	MIL M 39012/	Assembly instruction	Weight	Fig.	Notes
11 N-50-5-3	• 542100	U20 (RG 222/U)	01-0101	3045	55.0 g/1.93 oz.	1	replaces UG-18/U
11 N-50-7-5	• 542117	U33,28 (RG214/U)		3007	51.0 g/1.79 oz.	1	
11 N-50-7-6	• 542120	U33,28 (RG214/U)	01-0005	3008	51.0 g/1.79 oz.	1	replaces UG-21/U
11 N-50-9-2	• 542156	U38 (RG 217/U)		3019	95.0 g/3.33 oz.	2	

- centre contact captivated

- > cable entry clamp
- > centre contact soldered

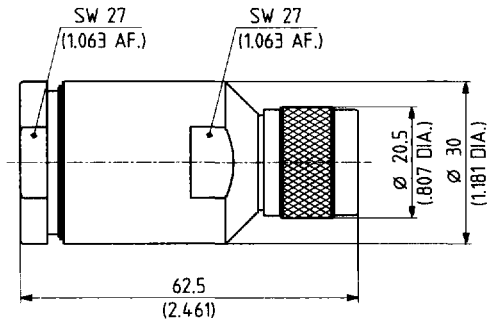

SUHNER TYPE	Ident. no.	Cable group (example)	Assembly instruction	Weight	Notes
11 N-50-17-2	• 542165	U44 (RG 218/U)	3022	133 g/4.66 oz.	

## Precision Connectors

### straight plugs – low VSWR

- > cable entry clamp
- > centre contact soldered

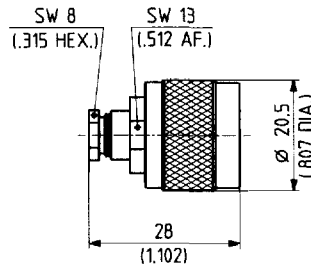

SUHNER TYPE	Ident. no.	Cable group (example)	Assembly instruction	VSWR			Weight
				DC-4 GHz	4-10 GHz	10-12.4 GHz	
11 N-50-3-34	642009	U10 (RG 223/U)	9099	≤ 1.10	≤ 1.20	≤ 1.25	32.0 g/1.12 oz.

- > cable entry clamp
- > centre contact soldered

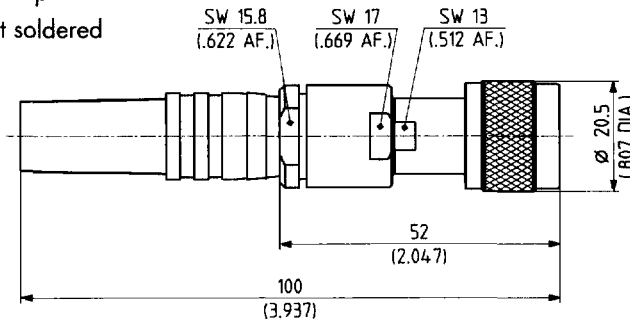

SUHNER TYPE	Ident. no.	Cable group (example)	Assembly instruction	VSWR		Weight
				DC-2 GHz	2-12.4 GHz	
11 N-50-7-33	641634	U33 (RG 214/U)	9097	≤ 1.05	≤ 1.10	70.0 g/2.45 oz.

- centre contact captivated

cable groups see pages 36

assembly tools see page 403

mounting holes see page 441

## straight plugs

- > SUHNER® full crimp
- > taper sleeves see page 423

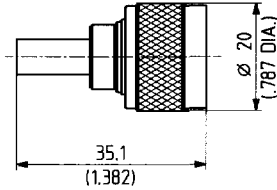

Fig. 1

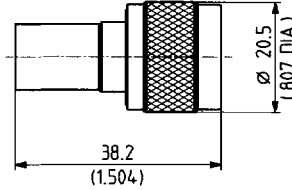

Fig. 2



SUHNER TYPE	Ident. no.	Cable group (example)	Crimp insert	Assembly instruction	Weight	Fig.	Notes
11 N-50-3-28	• 642842	U7 (RG 58 C/U)	2B	3015	23.0 g/0.81 oz.	1	
11 N-50-3-29	• 642843	U9 (RG 223/U)	2B	3015	23.0 g/0.81 oz.	1	
11 N-50-3-31	• 648829	U11 (RG 400/U)	2B	3015	28.0 g/0.98 oz.	1	
11 N-50-4-1	• 642488	U25 (S 06132D)	3D	27035	34.0 g/1.19 oz.	2	ethernet cable

- > SUHNER® full crimp
- > taper sleeves see page 423

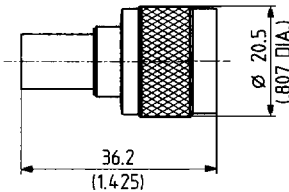

Fig. 1

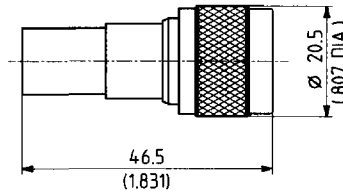
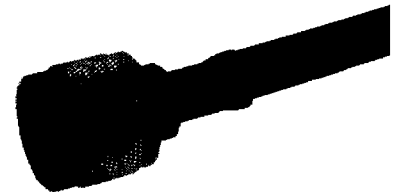

Fig. 2



SUHNER TYPE	Ident. no.	Cable group (example)	Crimp insert	Assembly instruction	Weight	Fig.	Notes
11 N-50-6-6	• 648674	U25 (S 06132D)	3/8.65	27082	31.0 g/1.09 oz.	1	
11 N-50-7-33	• 641614	U30 (S 07232)	4D	9067	39.0 g/1.37 oz.	2	
11 N-50-7-37	• 652110	U32 (RG 214/U)	4D	27064	37.0 g/1.30 oz.	2	

- centre contact captivated



- > SUHNER® full crimp
- > taper sleeves see page 423

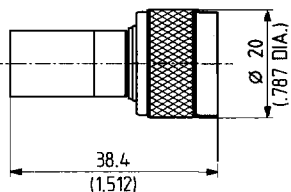

Fig. 1

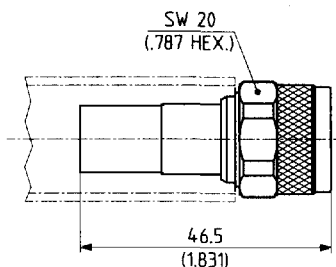
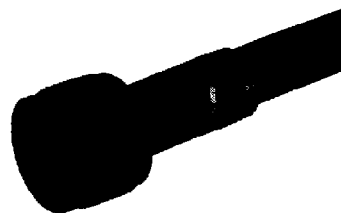
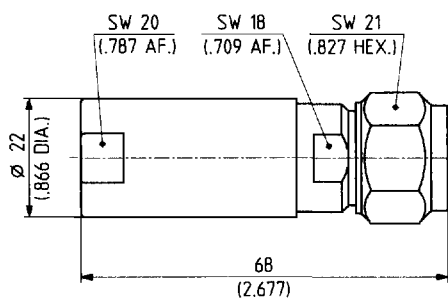

Fig. 2



SUHNER TYPE	Ident. no.	Cable group (example)	MIL M 39012/	Crimp insert	Assembly instruction	Weight	Fig.	Notes
11 N-50-7-43	• 642844	U29 (RG 213/U)	01-0007	3D	3061	28.0 g/0.98 oz.	1	
11 N-50-7-44	• 642845	U32 (RG 214/U)	01-0008	3D	3061	28.0 g/0.98 oz.	1	
11 N-50-7-61	• 651793	U33 (RG 393/U)		3D	27070	28.5 g/1.00 oz.	2	
11 N-50-7-49	• 652111	S32 (S 07262 BD)		4D	9067	40.0 g/1.40 oz.	2	

- > pressure sleeve
- > plug-in centre contact



SUHNER TYPE	Ident. no.	Cable group (example)	Assembly instruction	Weight	Notes
11 N-50-12-13	• 649372	U40 (S 12272-4)	27063	113 g/.3.96 oz.	up to 8 GHz

- centre contact captivated

## right angle plugs

- > cable entry clamp
- > centre contact soldered

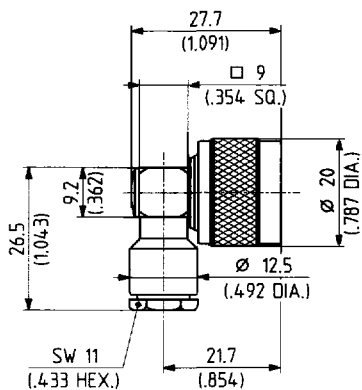

Fig. 1

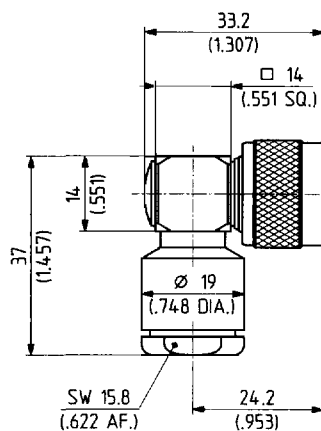

Fig. 2



SUHNER TYPE	Ident. no.	Cable group (example)	Assembly instruction	Weight	Fig.	Notes
16 N-50-3-103	• 651610	U7,10 (RG58C/U)	27060	37.0 g/1.30 oz.	1	
16 N-50-7-26	• 650825	U28 (RG 213/U)	3003	65.0 g/2.28 oz.	2	

- > cable entry crimp
- > centre contact soldered
- > taper sleeves see page 423

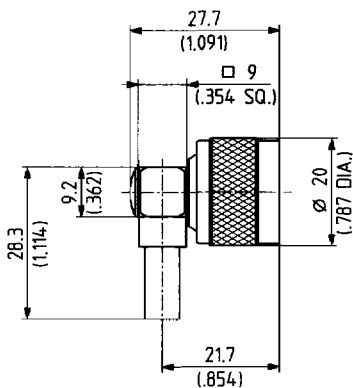

Fig. 1

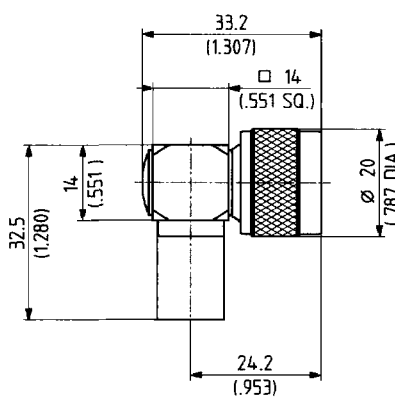

Fig. 2



SUHNER TYPE	Ident. no.	Cable group (example)	Crimp insert	Assembly instruction	Weight	Fig.	Notes
16 N-50-3-26	• 642846	U7 (RG 58 C/U)	B	3058	27.0 g/0.95 oz.	1	
16 N-50-3-27	• 642847	U9 (RG 223/U)	B	3058	27.0 g/0.95 oz.	1	
16 N-50-7-30	• 642848	U29 (RG 213/U)	D	3076	42.0 g/1.47 oz.	2	
16 N-50-7-31	• 642849	U32 (RG 214/U)	D	3076	42.0 g/1.47 oz.	2	

- centre contact captivated

cable groups see page 36

assembly tools see page 403

mounting holes see page 441

- > cable entry crimp
- > centre contact soldered
- > taper sleeves see page 423

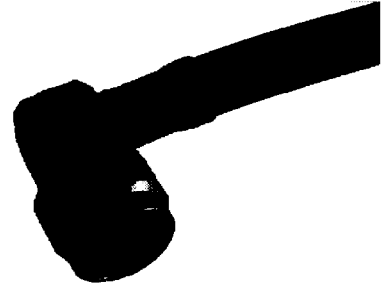
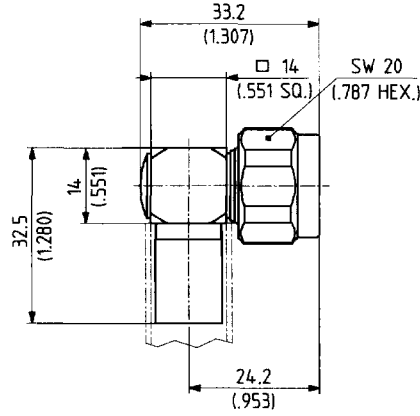

SUHNER TYPE	Ident. no.	Cable group (example)	Crimp insert	Assembly instruction	Weight	Notes
16 N-50-7-22	651794	S32 (S 07262 BD)	D	9094	50.0 g/1.75 oz.	

- > SUHNER® full crimp

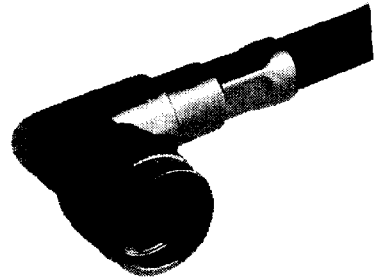
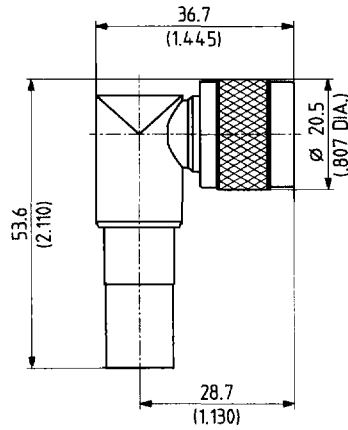
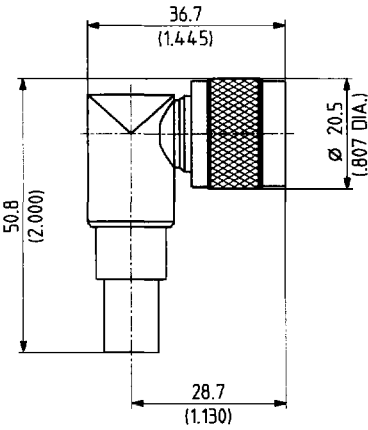

Fig. 1

Fig. 2

SUHNER TYPE	Ident. no.	Cable group (example)	Crimp insert	Assembly instruction	Weight	Fig.	Notes
16 N-50-6-8	651496	U25 (S 06132D)	3/8.65	27082	63.0 g/2.21 oz.	1	
16 N-50-7-29	651494	U29 (RG 213/U)	3D	9009	65.0 g/2.28 oz.	2	
16 N-50-7-36	651495	U32 (RG 214/U)	3D	9009	66.0 g/2.31 oz.	2	
16 N-50-7-24	649638	U33 (RG 393/U)	4D	9067	70.0 g/2.45 oz.	2	

- centre contact captivated

## straight jacks

- > cable entry clamp
- > centre contact soldered

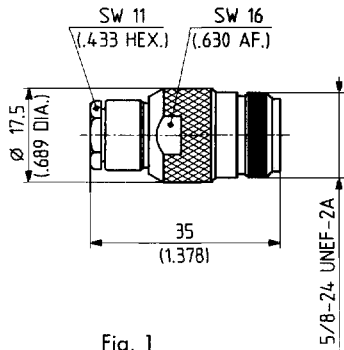

Fig. 1

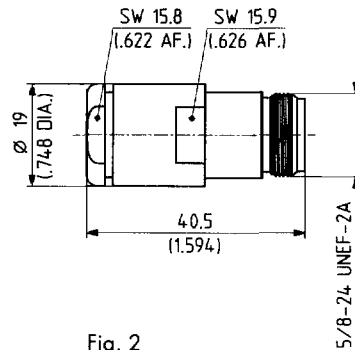
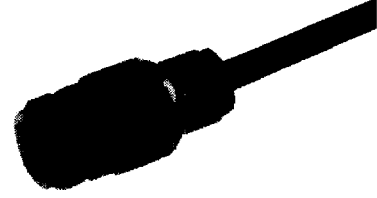

Fig. 2



SUHNER TYPE	Ident. no.	Cable group (example)	MIL M 39012/	Assembly instruction	Weight	Fig.	Notes
21 N-50-3-5	• 543504	U7,10 (RG58C/U)		3017	38.0 g/1.33 oz.	1	
21 N-50-7-8	• 542254	U33,28(RG214/U)	02-0003	3008	50.0 g/1.75 oz.	2	

- > SUHNER® full crimp
- > taper sleeves see page 423

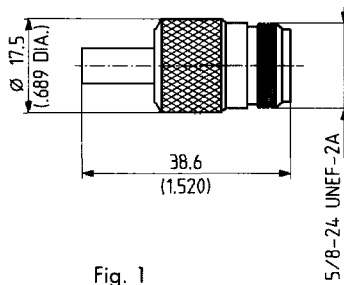

Fig. 1

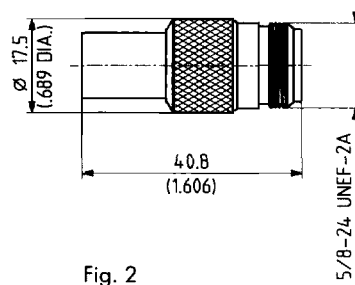

Fig. 2



SUHNER TYPE	Ident. no.	Cable group (example)	Crimp insert	Assembly instruction	Weight	Fig.	Notes
21 N-50-3-7	• 542229	U7 (RG 58 C/U)	2B	3063	36.0 g/1.26 oz.	1	
21 N-50-3-8	• 542231	U9 (RG 223/U)	2B	3063	36.0 g/1.26 oz.	1	
21 N-50-3-12	• 651795	U11 (RG 400/U)	2B	3063		1	
21 N-50-7-13	• 542257	U29 (RG 213/U)	3D	3061	38.0 g/1.33 oz.	2	replaces UG-1688/U <sup>1)</sup>
21 N-50-7-14	• 542258	U32 (RG 214/U)	3D	3061	37.0 g/1.30 oz.	2	replaces UG-1689/U <sup>2)</sup>

1) MIL M 39012/02-0008

2) MIL M 39012/02-0009

- centre contact captivated

- > SUHNER® full crimp
- > taper sleeves see page 423

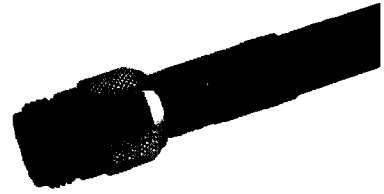
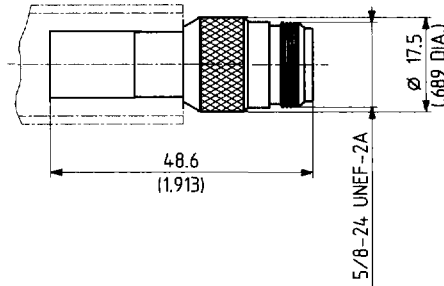

SUHNER TYPE	Ident. no.	Cable group (example)	Crimp insert	Assembly instruction	Weight	Notes
21 N-50-7-20	651796	S32 (S 07262 BD)	4D	9067	37.0 g/1.30 oz.	

## Precision Connector

### straight jack – low VSWR

- > cable entry clamp
- > centre contact soldered

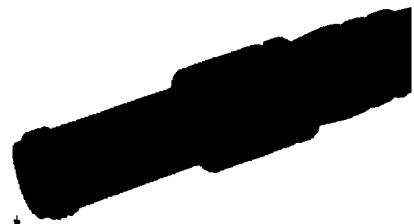
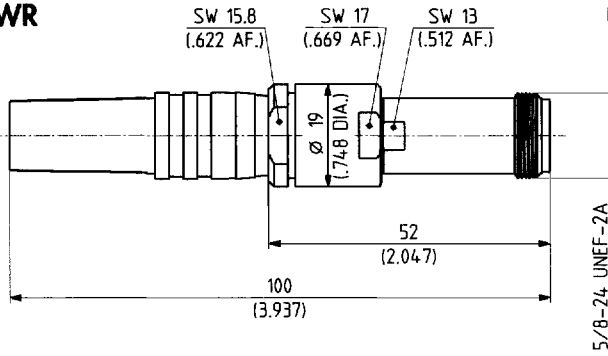

SUHNER TYPE	Ident. no.	Cable group (example)	Assembly instruction	VSWR DC-2 GHz	2-12.4 GHz	Weight
21 N-50-7-20	641635	U33 (RG 214/U)	9097	≤ 1.05	≤ 1.10	62.0 g/2.17 oz.

## bulkhead jacks

- > cable entry clamp
- > centre contact soldered
- > with panel seal
- > suitable for insulated mounting
- > insulating washers see page 425

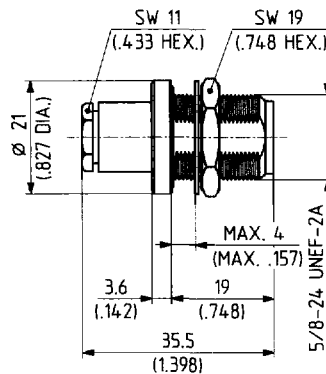

SUHNER TYPE	Ident. no.	Cable group (example)	Assembly instruction	Mounting hole	Weight	Notes
24 N-50-2-1	641239	U2 (RG 316/U)	9150	ML 12	42.0 g/1.47 oz.	

- centre contact captivated

cable groups see pages 36

assembly tools see page 403

mounting holes see page 441

- > cable entry clamp
- > centre contact soldered
- > with panel seal
- > suitable for insulated mounting
- > insulating washers see page 425

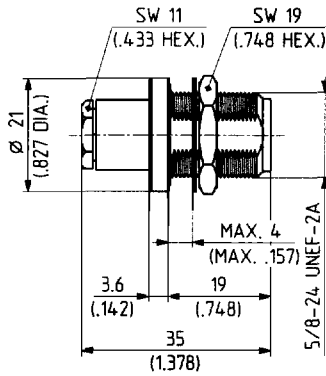

Fig. 1

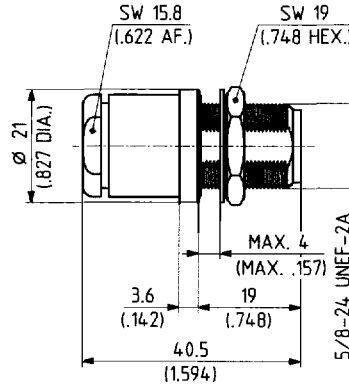
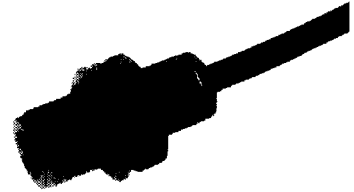
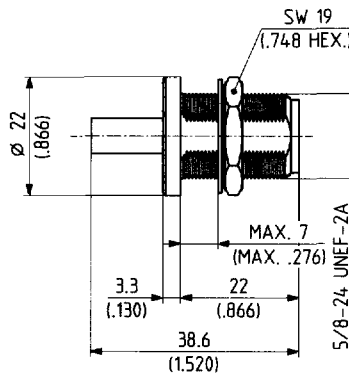

Fig. 2



SUHNER TYPE	Ident. no.	Cable group (example)	MIL M 39012/	Assembly instruction	Weight	Fig.	Notes
24 N-50-3-10	• 542295	U7,10 (RG58C/U)		9150	41.0 g/1.44 oz.	1	
24 N-50-5-2	• 542306	U20 (RG 222/U)		3044	57.0 g/2.00 oz.	2	
24 N-50-7-8	• 542323	U33,28(RG214/U)	03-0012	3008	53.0 g/1.86 oz.	2	replaces UG-160F/U mounting hole ML 12

- > SUHNER® full crimp
- > taper sleeves see page 423
- > suitable for insulated mounting
- > insulating washers see page 425



SUHNER TYPE	Ident. no.	Cable group (example)	Crimp insert	Assembly instruction	Weight	Notes
24 N-50-3-11	• 542296	U7 (RG 58 C/U)	2B	3063	38.0 g/1.33 oz.	*
24 N-50-3-12	• 542297	U9 (RG 223/U)	2B	3063	38.0 g/1.33 oz.	*

\* has to be crimped with large crimp tool or table press!

mounting hole ML 12

- centre contact captivated

- > SUHNER® full crimp
- > taper sleeves see page 423
- > with panel seal

- > suitable for insulated mounting
- > insulating washers see page 425

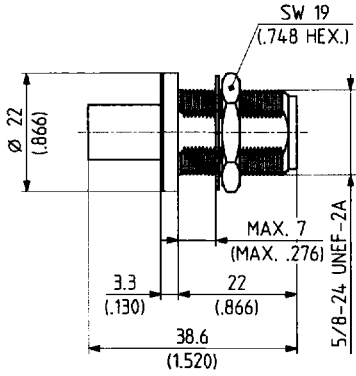

Fig. 1

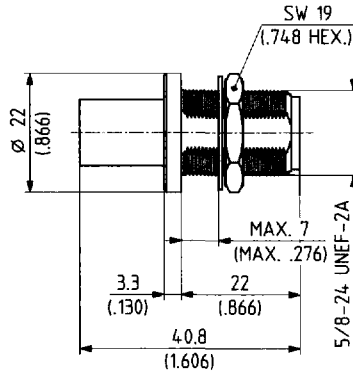

Fig. 2



SUHNER TYPE	Ident. no.	Cable group (example)	Crimp insert	Assembly instruction	Weight	Fig.	Notes
24 N-50-6-2	• 648774	U25 (S 06132D)	3/8.65	27082	37.0 g/1.30 oz.	1	
24 N-50-7-14	• 542326	U29 (RG 213/U)	3D	3061	40.0 g/1.40 oz.	2	replaces UG-1700/U MIL M 39012/03-0004
24 N-50-7-15	• 542327	U32 (RG 214/U)	3D	3061	40.0 g/1.40 oz.	2	replaces UG-1701/U MIL M 39012/03-0005

mounting hole ML 12

- > SUHNER® full crimp
- > taper sleeves see page 423

- > suitable for insulated mounting
- > insulating washers see page 425

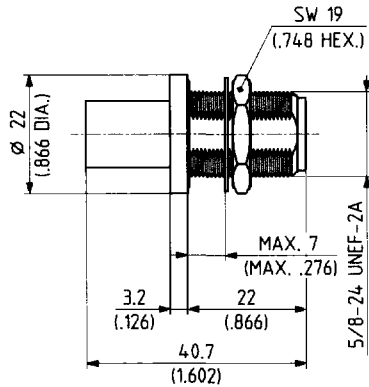

Fig. 1

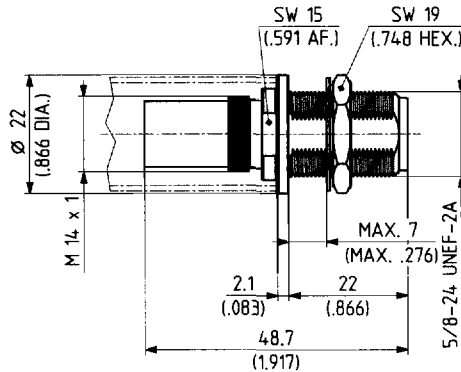
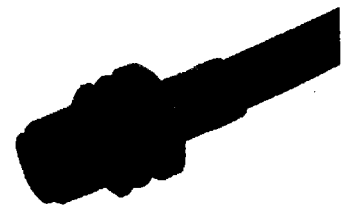

Fig. 2



SUHNER TYPE	Ident. no.	Cable group (example)	Crimp insert	Assembly instruction	Weight	Fig.	Notes
24 N-50-7-25	• 651798	U33 (RG 393/U)	3D	27070	37.0 g/1.30 oz.	1	with panel seal
24 N-50-7-22	• 651797	S32 (S 07262 BD)	4D	9079	44.0 g/1.54 oz.	2	without panel seal*

\* types available with additional sealing ferrule (IP66)

mounting hole ML 12

• centre contact captivated

cable groups see pages 36

assembly tools see page 403

mounting holes see page 441

## panel jacks

- > cable entry clamp
- > centre contact soldered
- > fastening screws see page 424

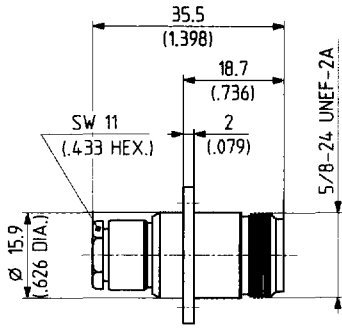
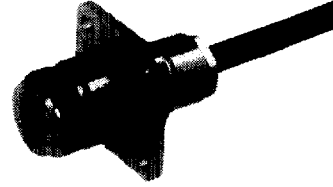

Fig. 1

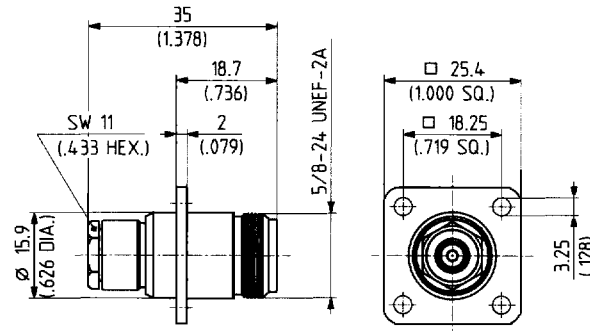
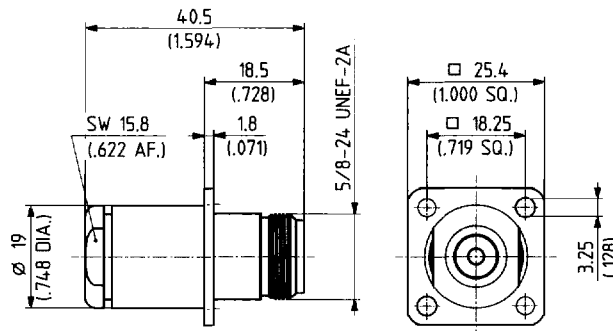
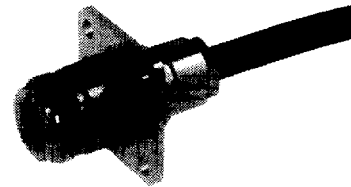

Fig. 2

SUHNER TYPE	Ident. no.	Cable group (example)	Mounting hole	Assembly instruction	Weight	Fig.	Notes
25 N-50-2-2	• 542332	U2 (RG 316/U)	ML 14	3017	45.0 g/1.58 oz.	1	
25 N-50-3-4	• 542342	U7,10 (RG58C/U)	ML 14	3017	44.0 g/1.54 oz.	2	

- > cable entry clamp
- > centre contact soldered
- > fastening screws see page 424



SUHNER TYPE	Ident. no.	Cable group (example)	MIL M 39012/	Mounting hole	Assembly instruction	Weight	Notes
25 N-50-5-2	• 542356	U20 (RG 222/U)	02-0104	ML 18	3045	61.0 g/2.14 oz.	
25 N-50-7-8	• 542366	U33,28 (RG214/U)	02-0006	ML 18	3008	55.0 g/1.93 oz.	

- centre contact captivated



- > SUHNER® full crimp
- > fastening screws see page 424
- > taper sleeves see page 423

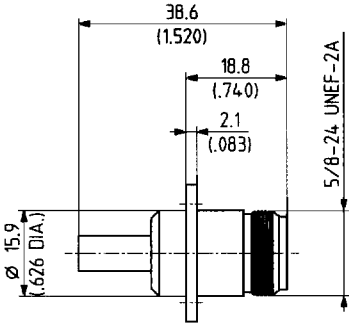
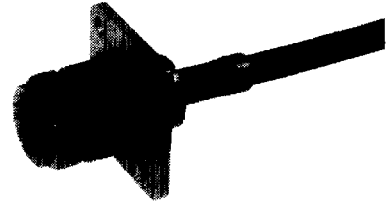

Fig. 1

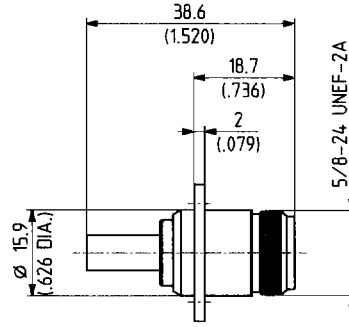
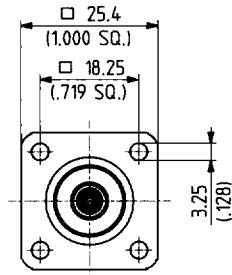
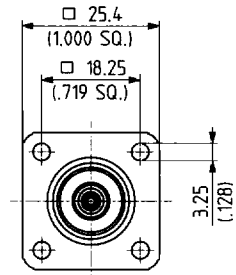

Fig. 2



SUHNER TYPE	Ident. no.	Cable group (example)	Crimp insert	Assembly instruction	Weight	Fig.	Notes
25 N-50-3-6	• 542346	U7 (RG 58 C/U)	2B	3063	39.0 g / 1.37 oz.	1	
25 N-50-3-7	• 542348	U9 (RG 223/U)	2B	3063	39.0 g / 1.37 oz.	1	
25 N-50-3-20	• 649913	U11 (RG 400/U)	2B	3063	37.0 g / 1.30 oz.	2	

mounting hole ML 14

- > SUHNER® full crimp
- > fastening screws see page 424
- > taper sleeves see page 423

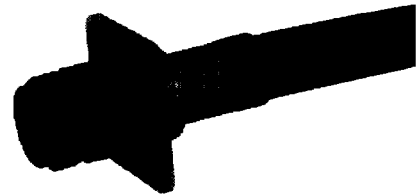
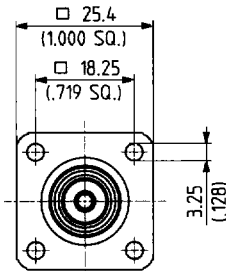
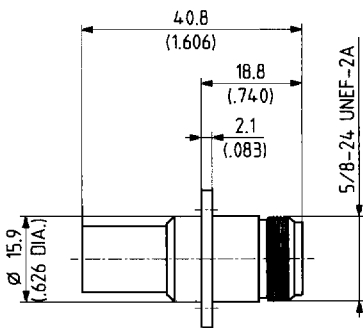

SUHNER TYPE	Ident. no.	Cable group (example)	MIL M 39012/	Crimp insert	Assembly instruction	Weight	Notes
25 N-50-7-13	• 542369	U29 (RG 213/U)	3D	02-0016	3061	42.0 g / 1.47 oz.	replaces UG-1697/U
25 N-50-7-14	• 542370	U32 (RG 214/U)	3D	02-0017	3061	42.0 g / 1.47 oz.	replaces UG-1698/U

mounting hole ML 14

• centre contact captivated

cable groups see pages 36

assembly tools see page 403

mounting holes see page 441

# Receptacles with Solder End

## receptacle, male

- > panel mounted
- > fastening screws see page 424

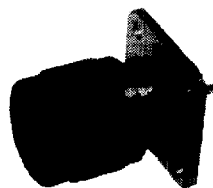
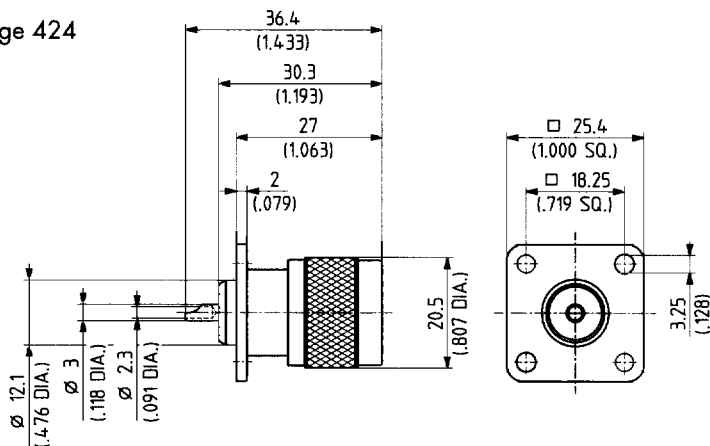

SUHNER TYPE	Ident. no.	Mounting hole	Weight	Notes
13 N-50-0-1	• 542173	ML 16	46.0 g / 1.61 oz.	

## receptacles, female

- > panel mounted
- > fastening screws see page 424

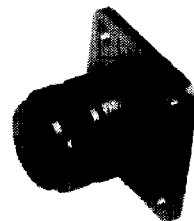
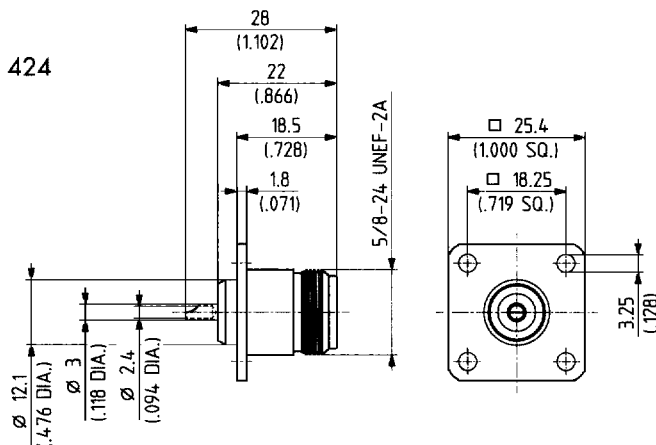

SUHNER TYPE	Ident. no.	MIL M	Mounting hole	Weight	Notes
23 N-50-0-1	• 542272	39012/ 04-0002	ML 17	31.0 g / 1.09 oz.	replaces UG-58/U

- centre contact captivated

- > bulkhead mounted
- > solder tags see page 426
- > with panel seal
- > suitable for insulated mounting
- > insulating washers see page 425

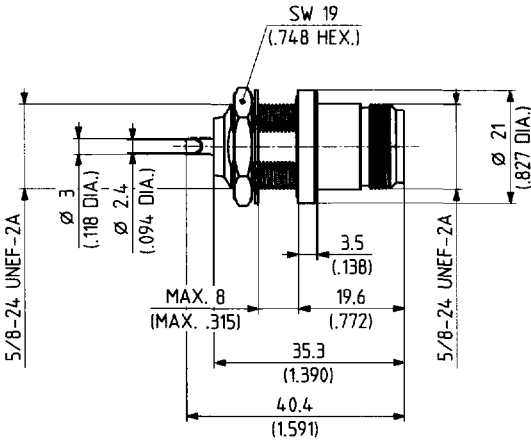

Fig. 1

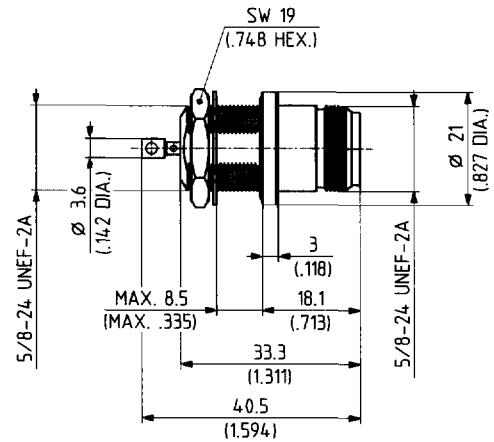

Fig. 2

SUHNER TYPE	Ident. no.	MIL M 39012/	Mounting hole	Weight	Fig.	Notes
22 N-50-0-2	• 542265		ML 12	47.0 g/1.65 oz.	1	
22 N-50-0-3	• 644425	04-0001	ML 12	47.0 g/1.65 oz.	2	hermetically sealed*

\* leak rate  $10^{-6}$  Torr l/sec. (atm cc/s) max.

## Receptacles for Microwave Components

### receptacle, male

- > panel mounted
- > extended dielectric
- > fastening screws see page 424

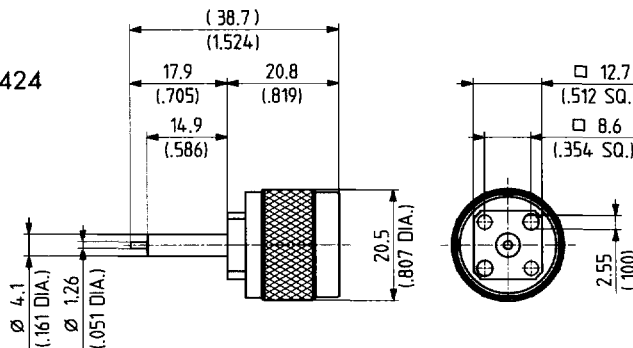

SUHNER TYPE	Ident. no.	Weight	Notes
13 N-50-0-30	• 642831	30.0 g/1.05 oz.	SMA flange size

- centre contact captivated

## receptacle, female

- > panel mounted
- > extended dielectric
- > fastening screws see page 424

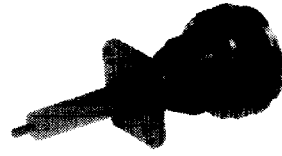
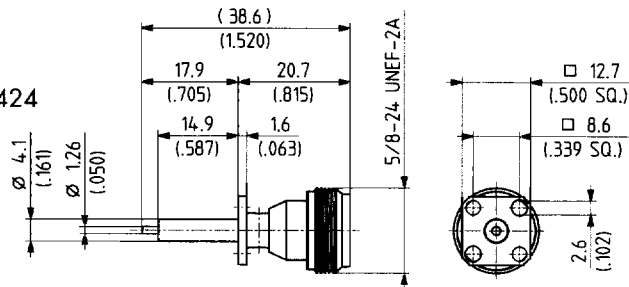

SUHNER TYPE	Ident. no.	Weight	Notes
23 N-50-0-30	642835	14.0 g/0.49 oz.	SMA flange size

## receptacle, male

- > panel mounted
- > solder pot terminal
- > flush dielectric
- > fastening screws see page 424

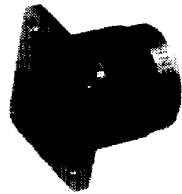
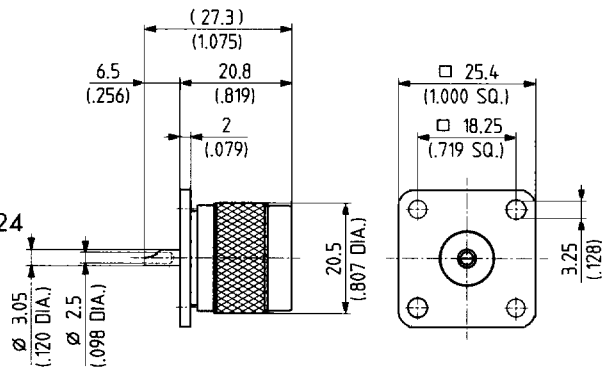

SUHNER TYPE	Ident. no.	Weight	Notes
13 N-50-0-23	650662	35.0 g/1.23 oz.	

## receptacles, female

- > panel mounted
- > solder pot terminal
- > flush dielectric
- > fastening screws see page 424

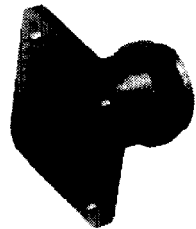
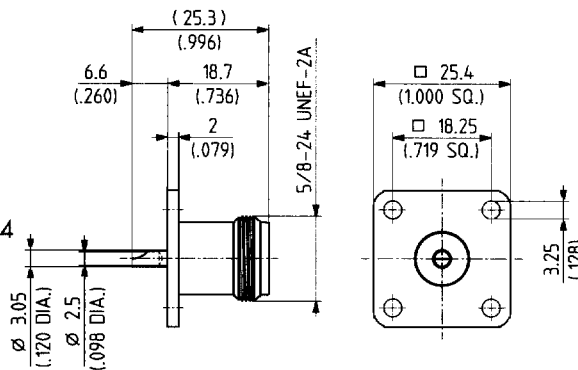

SUHNER TYPE	Ident. no.	Weight	Notes
23 N-50-0-23	544751	24.0 g/0.84 oz.	

- centre contact captivated

- > panel mounted
- > solder pot terminal
- > flush dielectric
- > fastening screws see page 424

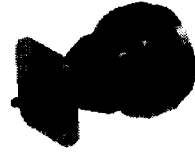
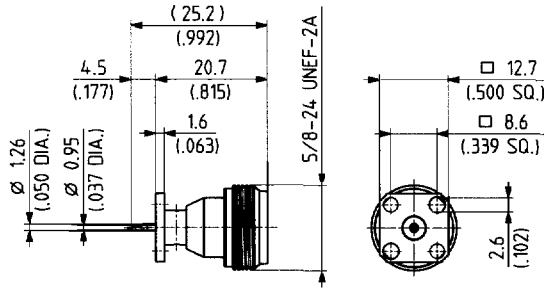

SUHNER TYPE	Ident. no.	Weight	Notes
23 N-50-0-31	• 642836	13.6 g/0.48 oz.	SMA flange size

## Stripline Launchers

### receptacles, male

- > panel mounted
- > tab contact
- > flush dielectric
- > fastening screws see page 424

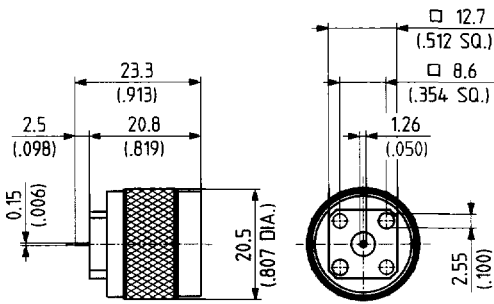
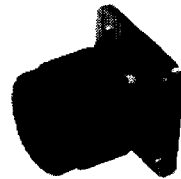
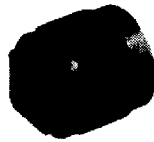

Fig. 1

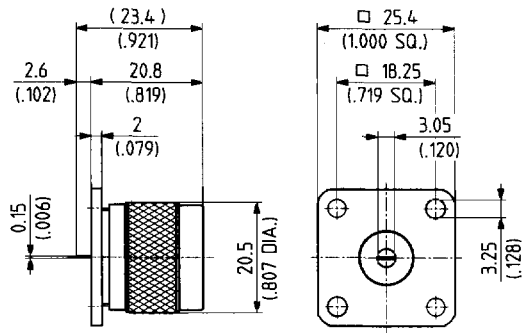

Fig. 2

SUHNER TYPE	Ident. no.	Weight	Fig.	Notes
13 N-50-0-32	• 642833	33.0 g/1.16 oz.	1	SMA flange size
13 N-50-0-33	• 642834	36.0 g/1.26 oz.	2	

- centre contact captivated

## receptacles, female

- > panel mounted
- > tab contact
- > flush dielectric
- > fastening screws see page 424

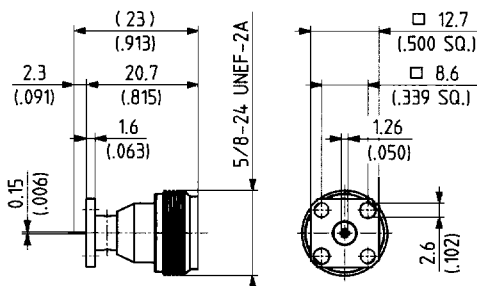

Fig. 1

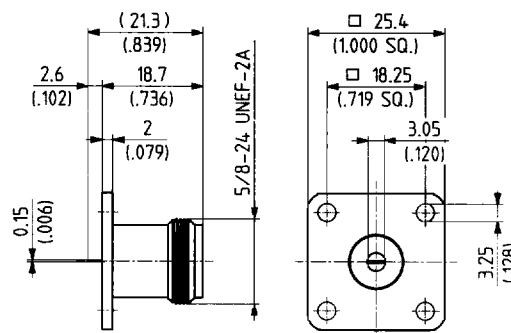

Fig. 2

SUHRER TYPE	Ident. no.	Weight	Fig.	Notes
23 N-50-4-16	641166	13.5 g/0.47 oz.	1	SMA flange size
23 N-50-4-33	642837	24.5 g/0.86 oz.	2	

## Adaptors Within-Series

### straight adaptors

- > plug to plug

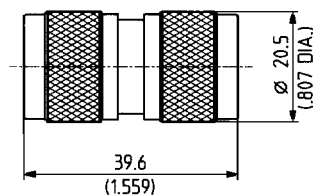

SUHRER TYPE	Ident. no.	MIL A 55339/	VSWR DC - 9 GHz	9 - 12 GHz	Weight	Notes
32 N-50-0-1	542398	05-00057	$\leq 1.06 + 0.04 f$	$\leq 1.40$	57.0 g/2.00 oz.	replaces UG-57 B/U

- centre contact captivated

> jack to jack

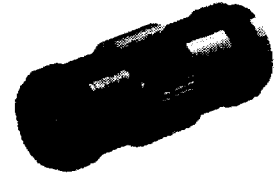
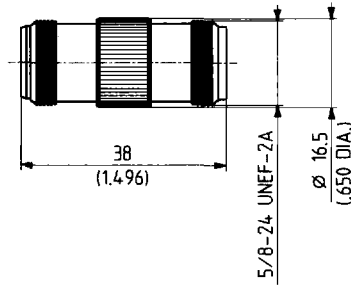

SUHNER TYPE	Ident. no.	MIL A 55339/	VSWR DC - 12.4 GHz	Weight	Notes
31 N-50-0-2	542382	07-00029	$\leq 1.17 + 0.15 f$	52.0 g/1.82 oz.	replaces UG-29 C/U

## bulkhead adaptors

- > jack to jack
- > with panel seal
- > suitable for insulated mounting
- > insulating washers see page 425

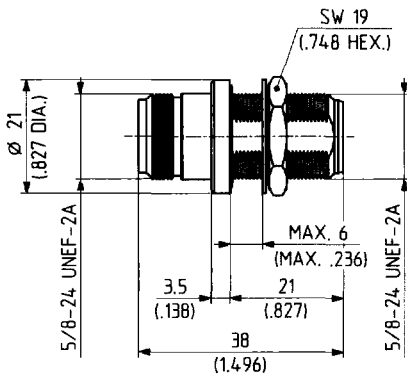

Fig. 1

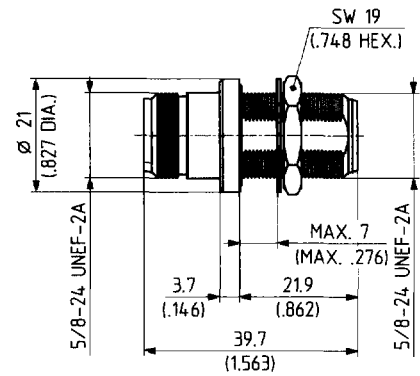

Fig. 2

SUHNER TYPE	Ident. no.	MIL A 55339/	VSWR DC - 2 GHz; 2 - 12.4 GHz	Weight	Fig.	Notes
34 N-50-0-1	542435	04-00001	$\leq 1.06$ $\leq 1.06 + 0.17f$	49.0 g/1.72 oz.	1	
34 N-50-0-3	642946		$\leq 1.06$ $\leq 0.03 + 0.7 f$	52.0 g/1.82 oz.	2	hermetically sealed*

\* leak rate  $10^{-6}$  Torr l/sec. (atm cc/s)

mounting hole ML 12

● centre contact captivated

N 50

### straight panel adaptors

- > jack to jack
- > fastening screws see page 424

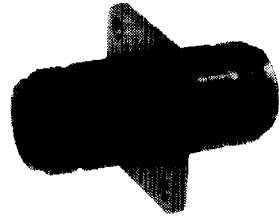
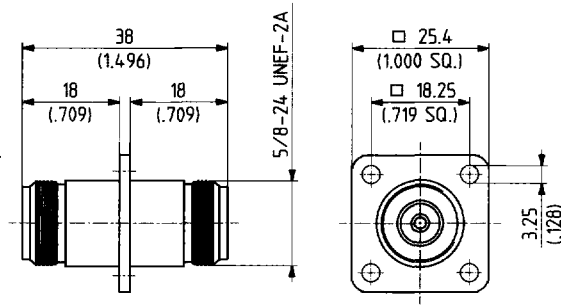

SUHNER TYPE	Ident. no.	Mounting hole	VSWR DC – 12.4 GHz	Weight	Notes
37 N-50-0-1	• 542437	ML 14	$\leq 1.195 + 0.065 f$	52.0 g / 1.82 oz.	max. applicable panel thickness 6.5 mm / .256 in.

### straight precision adaptors DC – 18 GHz

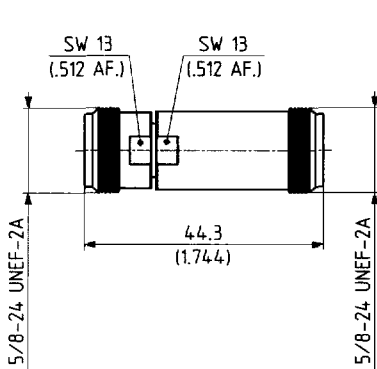

Fig. 1

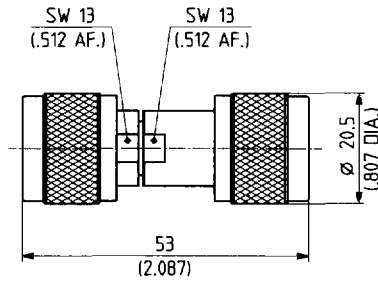

Fig. 2

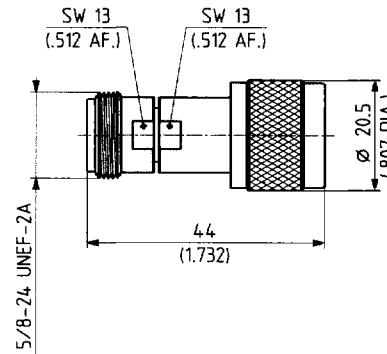

Fig. 3

SUHNER TYPE	Ident. no.	VSWR	Weight	Fig.	Notes
31 N-50-0-51	• 652112	$1.03 + 0.01f/\text{GHz}$	39.0 g / 1.37 oz.	1	jack to jack
32 N-50-0-51	• 652113	$1.03 + 0.01f/\text{GHz}$	62.0 g / 2.17 oz.	2	plug to plug
33 N-50-0-51	• 652114	$1.03 + 0.01f/\text{GHz}$	46.0 g / 1.61 oz.	3	plug to jack

- centre contact captivated



## straight bulkhead precision adaptor

- > jack to jack
- > with panel seal

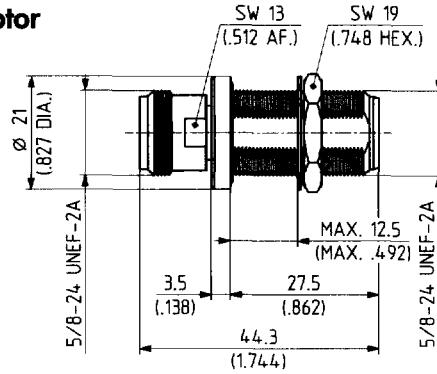

SUHNER TYPE	Ident. no.	VSWR	Mounting hole	Weight	Notes
34 N-50-0-31	• 544593	1.03 + 0.01f/GHz	ML 12	42.0 g/1.47 oz.	

## T-adaptors

50 Ω nominal impedance. These connectors are non-matched 3 dB dividers for LF applications. VSWR ≥ 2.0 when terminated with 50 Ω.

- > 2 jacks, 1 plug

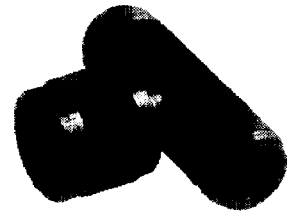
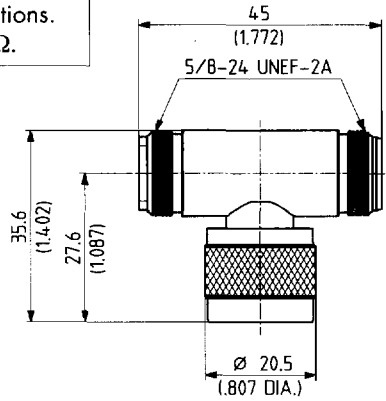

SUHNER TYPE	Ident. no.	Weight	Notes
43 N-50-0-1	• 542442	81.0 g/2.84 oz.	

- > 3 jacks

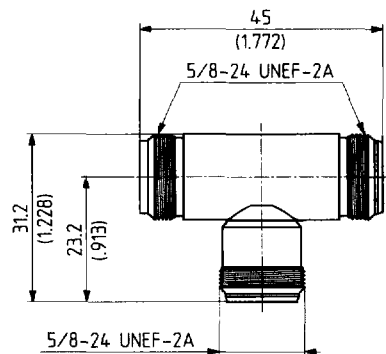

SUHNER TYPE	Ident. no.	MIL A 55339/	Weight	Notes
46 N-50-0-1	• 542445	06-00028	70.0 g/2.45 oz.	replaces UG-28 A/U

- centre contact captivated

## right angle adaptors

> plug to jack

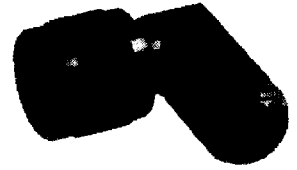
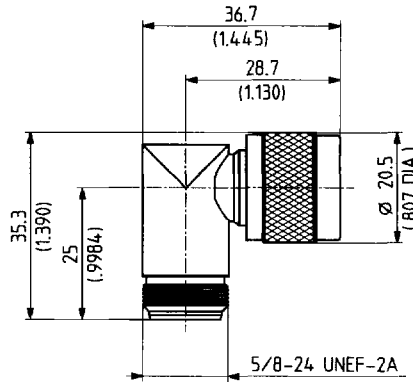

SUHNER TYPE	Ident. no.	VSWR DC - 11 GHz	Weight	Notes
53 N-0-0-4	• 651447	$\leq 1.06 + 0.07 f$	62.0 g/2.17 oz.	

## Protective Caps

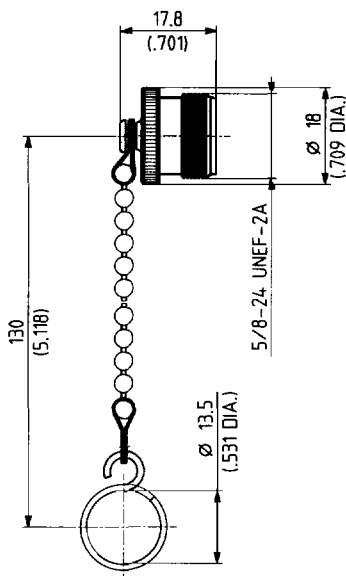

Fig. 1

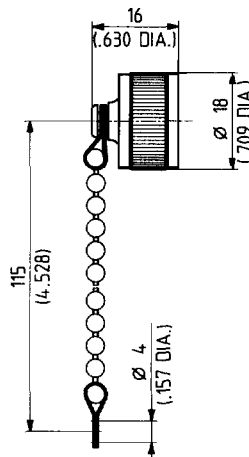

Fig. 2



SUHNER TYPE	Ident. no.	Weight	Fig.	Notes
61 N-0-0-1	542452	16.0 g/0.56 oz.	1	for plugs
62 N-0-0-1	543433	15.0 g/0.53 oz.	2	for jacks

• centre contact captivated

# Terminations

## DC – 4 GHz

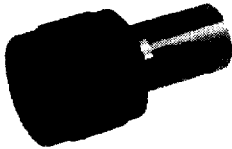
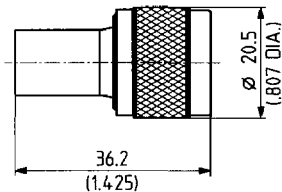

SUNNER TYPE	Ident. no.	VSWR			Interface	Impedance	Weight
		1 GHz	2 GHz	4 GHz			
65 N-50-0-1	• 550091	≤ 1.05	≤ 1.10	≤ 1.20	plug	50 Ω ± 1 %	36.0 g / 1.26 oz.

Permissible power: 1 W at max. 30°C/86°F ambient temperature, derated linearly to zero watt at 130°C/266°F ambient temperature; 2 kW pulsed power with a duration ≤ 10 ms, rise time ≥ 5 ms

## DC – 6 GHz

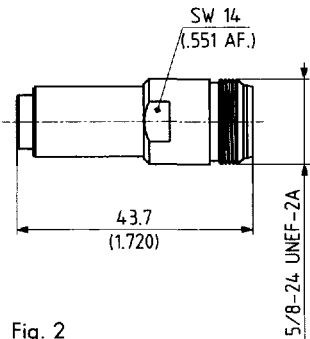
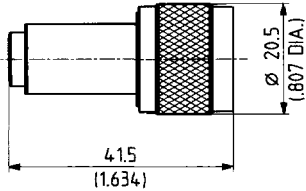

Fig. 1

Fig. 2

SUNNER TYPE	Ident. no.	VSWR			Interface	Impedance	Weight	Fig.
		1 GHz	2 GHz	4 GHz				
65 N-50-0-11	• 550095	≤ 1.05	≤ 1.10	≤ 1.20	plug	50 Ω ± 1 %	45.0 g / 1.58 oz.	1
65 N-50-0-31	• 550207	≤ 1.05	≤ 1.10	≤ 1.20	jack	50 Ω ± 1 %	44.0 g / 1.54 oz.	2

Permissible power: 1 W at max. 30°C/86°F ambient temperature, derated linearly to zero watt at 130°C/266°F ambient temperature; 2 kW pulsed power with a duration ≤ 10 ms, rise time ≥ 5 ms

• centre contact captivated

N 50