



**OPTICALLY COUPLED BILATERAL SWITCH LIGHT ACTIVATED ZERO VOLTAGE CROSSING TRIAC**

**DESCRIPTION**

The MOC308\_ Series are optically coupled isolators consisting of a Gallium Arsenide infrared emitting diode coupled with a monolithic silicon detector performing the functions of a zero crossing bilateral triac mounted in a standard 6 pin dual-in-line package.

**FEATURES**

- Options :-  
10mm lead spread - add G after part no.  
Surface mount - add SM after part no.  
Tape&reel - add SMT&R after part no.
- High Isolation Voltage, 5.3kV<sub>RMS</sub>
- Zero Voltage Crossing
- 800V Peak Blocking Voltage
- All electrical parameters 100% tested
- Custom electrical selections available

**APPLICATIONS**

- CRTs
- Power Triac Driver
- Motors
- Consumer appliances
- Printers

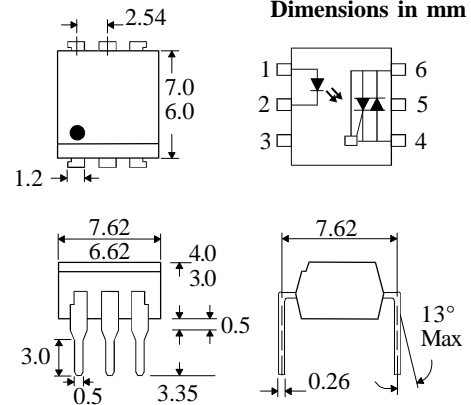

**ABSOLUTE MAXIMUM RATINGS  
(25 °C unless otherwise noted)**

Storage Temperature \_\_\_\_\_ -55°C - +150°C  
 Operating Temperature \_\_\_\_\_ -40°C - +100°C  
 Lead Soldering Temperature \_\_\_\_\_ 260°C  
 (1.6mm from case for 10 seconds)

**INPUT DIODE**

Forward Current \_\_\_\_\_ 50mA  
 Reverse Voltage \_\_\_\_\_ 6V  
 Power Dissipation \_\_\_\_\_ 120mW  
 (derate linearly 1.41mW/°C above 25°C)

**OUTPUT PHOTO TRIAC**

Off-State Output Terminal Voltage \_\_\_\_ 800V  
 Forward Current (Peak) \_\_\_\_\_ 1A  
 Power Dissipation \_\_\_\_\_ 150mW  
 (derate linearly 1.76mW/°C above 25°C)

**POWER DISSIPATION**

Total Power Dissipation \_\_\_\_\_ 250mW  
 (derate linearly 2.94mW/°C above 25°C)

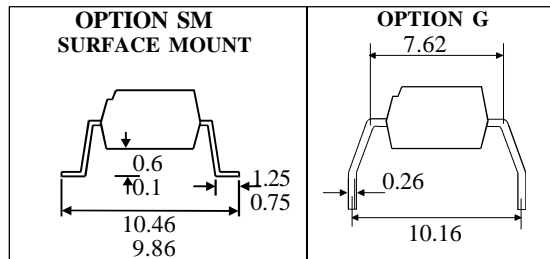

**ISOCOM COMPONENTS LTD**  
 Unit 25B, Park View Road West,  
 Park View Industrial Estate, Brenda Road  
 Hartlepool, TS25 1YD England Tel: (01429)863609  
 Fax: (01429) 863581 e-mail sales@isocom.co.uk  
<http://www.isocom.com>

**ISOCOM INC**  
 1024 S. Greenville Ave, Suite 240,  
 Allen, TX 75002 USA  
 Tel: (214)495-0755 Fax: (214)495-0901  
 e-mail info@isocom.com  
<http://www.isocom.com>

**ELECTRICAL CHARACTERISTICS (  $T_A = 25^\circ\text{C}$  Unless otherwise noted )**

PARAMETER		MIN	TYP	MAX	UNITS	TEST CONDITION
Input	Forward Voltage ( $V_F$ ) Reverse Current ( $I_R$ )		1.2	1.4 10	V $\mu\text{A}$	$I_F = 20\text{mA}$ $V_R = 6\text{V}$
Output	Peak Off-state Current ( $I_{\text{DRM}}$ ) Peak Blocking Voltage ( $V_{\text{DRM}}$ ) On-state Voltage ( $V_{\text{TM}}$ )  Critical rate of rise of off-state Voltage ( $dv/dt$ )	800		500 3.0	nA V V  $\text{V}/\mu\text{s}$	$V_{\text{DRM}} = 800\text{V}$ (note 1 ) $I_{\text{DRM}} = 500\text{nA}$ $I_{\text{TM}} = 100\text{mA}$ ( peak )
Coupled	Input Current to Trigger ( $I_{\text{FT}}$ )(note 2 ) MOC3080 MOC3081 MOC3082 MOC3083  Holding Current , either direction ( $I_H$ ) Input to Output Isolation Voltage $V_{\text{ISO}}$			30 15 10 5	mA mA mA mA  $\mu\text{A}$ $V_{\text{RMS}}$	$V_{\text{TM}} = 3\text{V}$ ( note 2 )      See note 3
Zero Crossing Charact- -eristic	Inhibit Voltage ( $V_{\text{IH}}$ )  Leakage in Inhibited State ( $I_S$ )			20 500	V $\mu\text{A}$	$I_F = \text{Rated } I_{\text{FT}}$ MT1-MT2 Voltage above which device will not trigger $I_F = \text{Rated } I_{\text{FT}}$ $V_{\text{DRM}} = 600\text{V}$ off-state

Note 1. Guaranteed to trigger at an  $I_F$  value less than or equal to max.  $I_{\text{FT}}$ , recommended  $I_F$  lies between Rated  $I_{\text{FT}}$  and absolute max.  $I_F$ .

Note 2. Measured with input leads shorted together and output leads shorted together.

## CHARACTERISTIC CURVES

Fig.1 Forward Current vs. Ambient Temperature

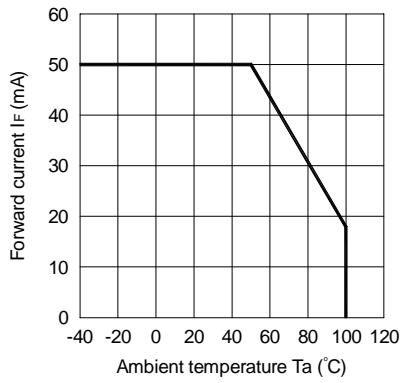

Fig.2 On-state Current vs. Ambient Temperature

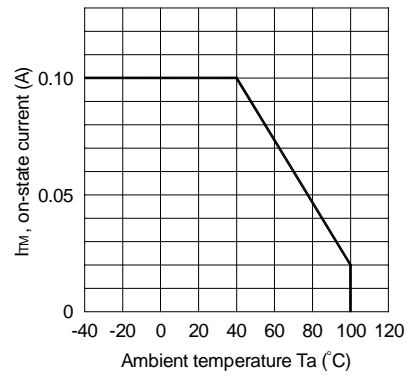

Fig.3 Minimum Trigger Current vs. Ambient Temperature

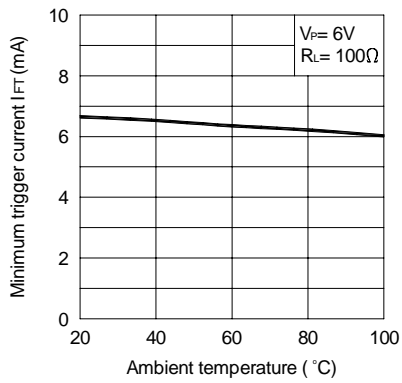

Fig.4 Forward Current vs. Forward Voltage

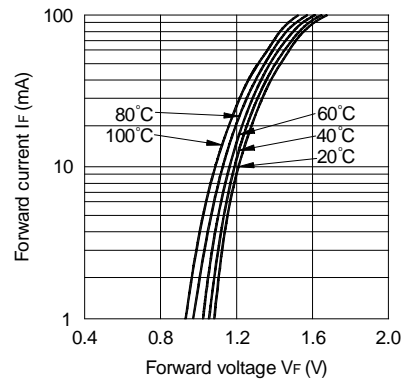

Fig.5 On-state Voltage vs. Ambient Temperature

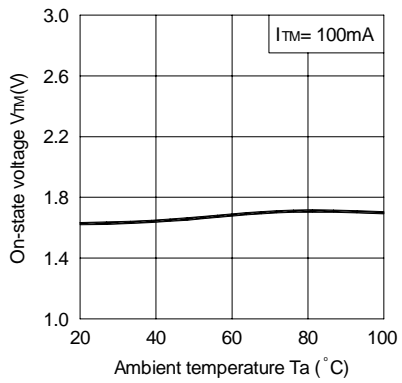
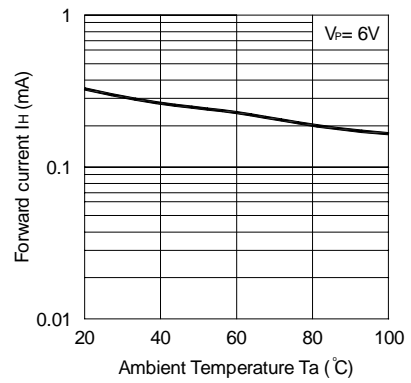

Fig.6 Holding Current vs. Ambient Temperature



## CHARACTERISTIC CURVES

Fig.7 Turn-on Time vs. Forward Current

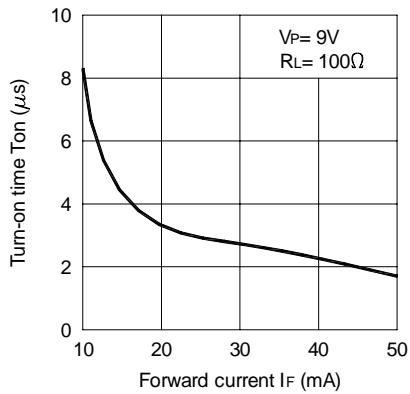

Fig.8 Repetitive Peak Off-state Current vs. Temperature

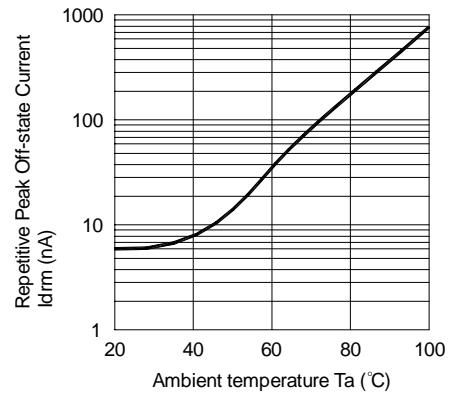
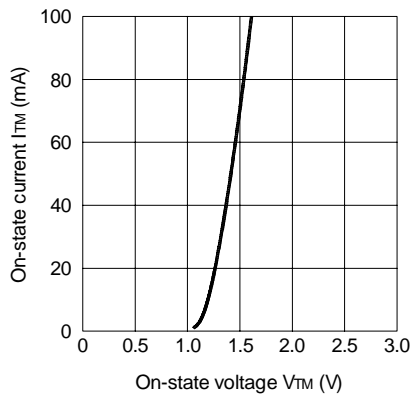

Fig.9 On-state Current vs. On-state Voltage



Static dv/dt Test Circuit

