

MC1488

Quad line driver

Document No.	853-0933
ECN No.	86552
Date of Issue	November 14, 1986
Status	Product Specification
Data Communication Products	

DESCRIPTION

The MC1488 is a quad line driver which converts standard DTL/TTL input logic levels through one stage of inversion to output levels which meet EIA Standard No. RS-232C and CCITT Recommendation V.24.

FEATURES

- Current limited output: $\pm 10\text{mA Typ}$
- Power-off source impedance: $300\Omega \text{ min}$
- Simple slew rate control with external capacitor
- Flexible operating supply range
- Inputs are DTL/TTL compatible

APPLICATIONS

- Computer port driver
- Digital transmission over long lines
- Slew rate control
- TTL/DTL-to-MOS translation

PIN CONFIGURATION

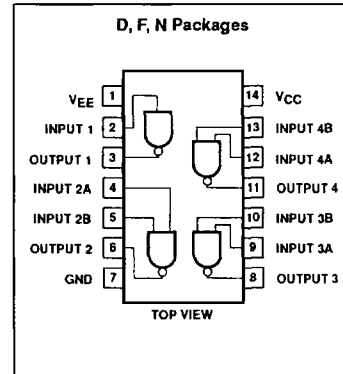

CIRCUIT SCHEMATIC

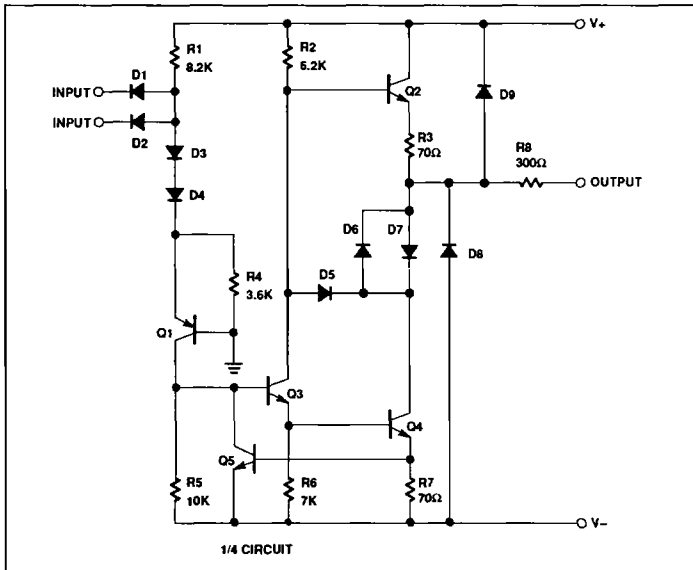

Quad line driver

MC1488

ORDERING INFORMATION

DESCRIPTION	TEMPERATURE RANGE	ORDER CODE
14-Pin Plastic SO	0°C to +75°C	MC1488D
14-Pin Plastic DIP	0°C to +75°C	MC1488N
14-Pin Ceramic DIP	0°C to +75°C	MC1488F

ABSOLUTE MAXIMUM RATINGS

SYMBOL	PARAMETER	RATING	UNIT
V_{CC}	Supply voltage V_{+}	+15	V
	V_{-}	-15	V
V_{IN}	Input voltage	$-15 \leq V_{IN} \leq 7.0$	V
V_{OUT}	Output voltage	± 15	V
P_D	Maximum power dissipation, $T_A = 25^{\circ}\text{C}$ (still-air) ¹		
	F package	1190	mW
	N package	1420	mW
	D package	1040	mW
T_A	Operating ambient temperature range	0 to +75	$^{\circ}\text{C}$
T_{STG}	Storage temperature range	-65 to +150	$^{\circ}\text{C}$
T_{SOLD}	Lead soldering temperature (10sec max)	300	$^{\circ}\text{C}$

NOTE:

- 1 Derate above 25°C, at the following rates
 F package at 9.5mW/ $^{\circ}\text{C}$.
 N package at 11.4mW/ $^{\circ}\text{C}$.
 D package at 8.3mW/ $^{\circ}\text{C}$.

Quad line driver

MC1488

DC AND AC ELECTRICAL CHARACTERISTICS $V_+ = +9.0V \pm 1\%$, $V_- = -9.0V \pm 1\%$, $T_A = 0^\circ\text{C}$ to $+75^\circ\text{C}$, unless otherwise specified. All typicals are for $V_+ = 9.0V$, $V_- = -9.0V$, and $T_A = 25^\circ\text{C}$ ¹

SYMBOL	PARAMETER	TEST CONDITIONS	LIMITS			UNIT		
			Min	Typ	Max			
V_{IH}	Logic "0" input current	$V_{IN} = 0V$		-1.0	-1.6	mA		
V_{IL}	Logic "1" input current	$V_{IN} = +5.0V$		0.005	10.0	μA		
V_{OH}	High level output voltage	$R_L = 3.0k\Omega$ $V_{IN} = 0.8V$	$V_+ = 9.0V$ $V_- = -9.0V$	6.0	7.0	V		
			$V_+ = 13.2V$ $V_- = -13.2V$	9.0	10.5	V		
V_{OL}	Low level output voltage	$R_L = 3.0k\Omega$ $V_{IN} = 1.9V$	$V_+ = 9.0V$ $V_- = -9.0V$	-6.0	-6.8	V		
			$V_+ = 13.2V$ $V_- = -13.2V$	-9.0	-10.5	V		
I_{SC+}	High level output short-circuit current	$V_{OUT} = 0V$ $V_{IN} = 0.8V$	-6.0	-10.0	-12.0	mA		
I_{SC-}	Low level output short-circuit current	$V_{OUT} = 0V$ $V_{IN} = 1.9V$	5.0	10.0	12.0	mA		
R_{OUT}	Output resistance	$V_+ = V_- = 0V$ $V_{OUT} = \pm 2V$	300			Ω		
I_+	Positive supply current (output open)	$V_{IN} = 1.9V$	$V_+ = 9.0V, V_- = -9.0V$ $V_+ = 12V, V_- = -12V$ $V_+ = 15V, V_- = -15V$		15.0 19.0 25.0	20.0 25.0 34.0	mA mA mA	
			$V_{IN} = 0.8V$	$V_+ = 9.0V, V_- = -9.0V$ $V_+ = 12V, V_- = -12V$ $V_+ = 15V, V_- = -15V$		4.5 5.5 8.0	6.0 7.0 12.0	mA mA mA
I_-	Negative supply current (output open)	$V_{IN} = 1.9V$	$V_+ = 9.0V, V_- = -9.0V$ $V_+ = 12V, V_- = -12V$ $V_+ = 15V, V_- = -15V$		-13.0 -18.0 -25.0	-17.0 -23.0 -34.0	mA mA mA	
			$V_{IN} = 0.8V$	$V_+ = 9.0V, V_- = -9.0V$ $V_+ = 12V, V_- = -12V$ $V_+ = 15V, V_- = -15V$		-1 -1 -0.01	-15 -15 -2.5	μA μA mA
P_D	Maximum power dissipation, $T_A = 25^\circ\text{C}$ (still-air) ² F package N package D package					1190 1420 1040	mW mW mW	
		t_{PD1}	Propagation delay to "1"	$R_L = 3.0k\Omega, C_L = 15pF, T_A = 25^\circ\text{C}$		275	560	ns
		t_{PDD}	Propagation delay to "0"	$R_L = 3.0k\Omega, C_L = 15pF, T_A = 25^\circ\text{C}$		70	175	ns
t_R	Rise time	$R_L = 3.0k\Omega, C_L = 15pF, T_A = 25^\circ\text{C}$		75	100	ns		
t_F	Fall time	$R_L = 3.0k\Omega, C_L = 15pF, T_A = 25^\circ\text{C}$		40	75	ns		

NOTES:

- Voltage values shown are with respect to network ground terminal. Positive current is defined as current into the referenced pin.
- Derate above 25°C , at the following rates:
 - F package at $9.5\text{mW}/^\circ\text{C}$.
 - N package at $11.4\text{mW}/^\circ\text{C}$.
 - D package at $8.3\text{mW}/^\circ\text{C}$.

Quad line driver

MC1488

TYPICAL PERFORMANCE CHARACTERISTICS

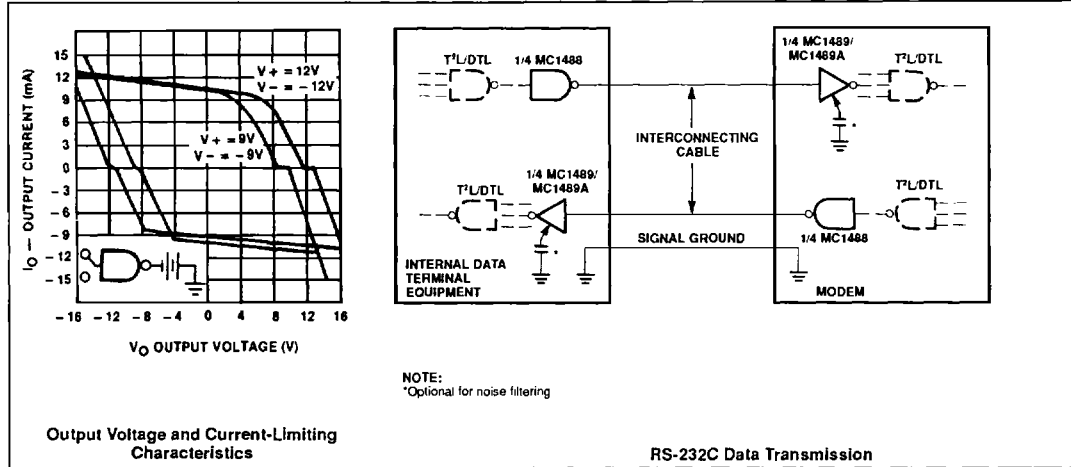

AC LOAD CIRCUIT

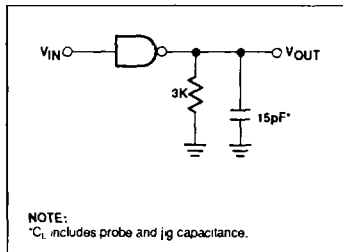

APPLICATIONS

By connecting a capacitor to each driver output the slew rate can be controlled utilizing the output current-limiting characteristics of the MC1488. For a set slew rate the appropriate capacitor value may be calculated using the following relationship

$$C = I_{SC}(\Delta T/\Delta V)$$

where C is the required capacitor, I_{SC} is the short-circuit current value, and ΔV/ΔT is the slew rate.

RS-232C specifies that the output slew rate must not exceed 30V/μs. Using the worst-case output short-circuit current of 12mA in the above equation, calculations result in a required capacitor of 400pF connected to each output.

SWITCHING WAVEFORMS

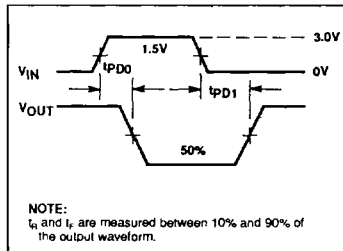

TYPICAL APPLICATIONS

