

18-Bit Switchable Active SCSI-2 Bus Terminator (110Ω) With Voltage Regulator and Inverted Disconnect

The MCCS142238™ is a precision 18-bit switchable active SCSI-2 bus terminator with an on-board 2.85V regulator. When the Disconnect pin is HIGH according to the truth table below, the MCCS142238 provides 110Ω ±5% precision resistor pull-ups to a 2.85V reference for termination of 18-bits in a SCSI-2 standard bus system interface.

When the Disconnect pin is LOW, the device outputs are in the high impedance state on all 18 bits. The regulator is also turned off, greatly reducing standby power. Even with no Tempwr applied, the outputs remain in the high impedance state.

- Complies With SCSI and SCSI-2 Standards
- Pin Compatible With UC5609
- For Opposite Disconnect Polarity See Motorola's MCCS142236
- 18 Switchable 110Ω Terminating Resistors
- 4pF Channel Capacitance During Disconnect
- Fully Supports Active Negation (Sinks Minimum of 220mA)
- Built-In 2.85V Regulator With Low Dropout Voltage
- Very Low Supply Current When Resistors Are Disabled (150μA Max)
- -650mA Source Current
- Thermal Shutdown Protection
- Thin Profile Surface Mount Package: 28-Lead SOIC

The regulator has a guaranteed dropout voltage of less than 900mV, allowing regulation of supply voltages less than 4.0V. The MCCS142238 is protected by thermal shutdown. Other features include low disconnect current (150μA), over 220mA of active negation current sink capability, and 4pF disconnect capacitance.

In 8-bit SCSI applications ("A" cable), only one MCCS142238 is needed at each end of the SCSI cable in order to terminate the 18 active signal lines.

For information on "Power Dissipation for Active SCSI Terminators," refer to Motorola Application Note AN1408/D, available through the Motorola Design-NET Fax System as "HOT-DOC" Number 1083, or through the Motorola Literature Distribution Center.

MCCS142238

**18-BIT SWITCHABLE
ACTIVE SCSI-2
BUS TERMINATOR**



DW SUFFIX
28-LEAD WIDE SOIC PACKAGE
CASE 751F-04

TRUTH TABLE

Disconnect	Output
0	Z
1	Terminated



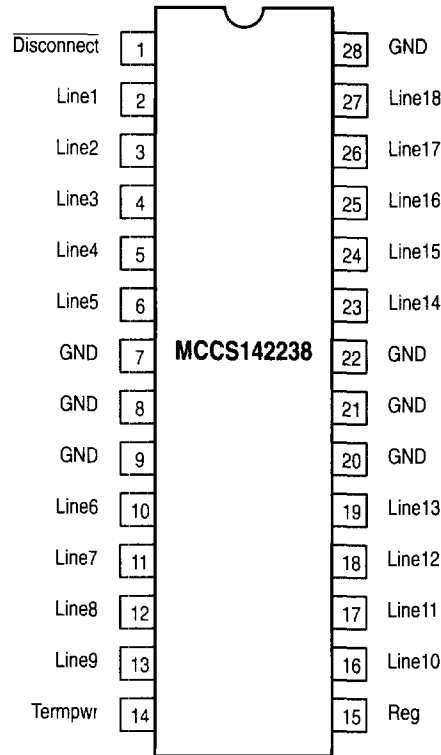

Figure 1. 28-Lead Pinout (Top View)

Disconnect Input Application	Result
A. No Connection to Disconnect	Disconnect input will be pulled "HIGH" internally, providing 110Ω impedance to each of the bus lines.
B. Single Pole Switch to GND	Disconnect input will be pulled "HIGH" internally when the switch is open, providing 110Ω impedance to each of the bus lines. Disconnect input will be held "LOW" when the switch is closed, causing all outputs to be high impedance.
C. Double Pole Switch Between Supply and GND	This is a more expensive way to accomplish application B above. It is more economical to allow the internal pullup to provide the "HIGH" input level. The supply source in this case could be Tempwv or VCC.
D. Hardwired "High"	The MCCS142238 will be permanently connected providing 110Ω impedance to each of the bus lines.
E. Hardwired "Low"	The MCCS142238 will be permanently disconnected causing all outputs to be high impedance.

MAXIMUM RATINGS*

Symbol	Parameter	Value	Unit
Tempwv	DC Supply Voltage	7.0	V
V _{Line}	Signal Line Voltage	-1.0 to +7.0	V
I _{REG}	Regulator Current	1	A
t _{stg}	Storage Temperature Range	-65 to +150	°C

* Maximum Ratings are those values beyond which damage to the device may occur. Functional operation should be restricted to the Recommended Operating Conditions.

RECOMMENDED OPERATING CONDITIONS

Symbol	Parameter	Min	Max	Unit
Temp _{pwr}	DC Supply Voltage	3.8	5.25	V
V _{ir}	DC Input Voltage (Disconnect Pin)	0	Temp _{pwr}	V
V _{Line}	Signal Line Voltage	0	3.0	V
T _A	Operating Temperature Range	0	+70	°C
t _{r, tf}	Input Rise/Fall Time	0	500	ns

ELECTRICAL CHARACTERISTICS (Unless otherwise stated, these specifications apply for T_A = 0° to 70°C, Temp_{pwr} = 4.75V, Disconnect = Open)

Symbol	Characteristic	Min	Typ	Max	Unit	Condition
--------	----------------	-----	-----	-----	------	-----------

Supply Current Section

I _{Temp_{pwr}}	Temp _{pwr} Supply Current		15 410	27 465	mA	All Termination Lines = Open All Termination Lines = 0.5V
I _{pd}	Power Down Mode Current		100	150	μA	Disconnect = 0V

Output Section (Termination Lines)

R ₁₀	Termination Impedance	104.5	110.0	115.5	Ω	
V _{OH}	Output HIGH Voltage	2.8	2.85	3.0	V	Note 1.
I _{source}	Source Current Capability per Line	-19.9		-24	mA	Signal Line = 0.5V
I _{OZ}	Output Leakage Current Signal Lines = 0 to 5.25V			1	μA	Temp _{pwr} = 5.25V, Reg = Open, Disconnect = 0V
C _C	Output Capacitance (Note 2.)		4.0	5.0	pF	Disconnect = 0V

Regulator Section

V _{Reg}	Regulator Voltage	2.8	2.85	3.0	V	Signal Lines = 0V or 4V
Lin _{reg}	Line Regulation		27	40	mV	Signal Lines Open, Temp _{pwr} = 4V to 6V
Load _{reg}	Load Regulation		35	60	mV	Signal Lines = 0V to 3V
V _{DO}	Drop Out Voltage		0.7	0.9	V	Signal Lines = 0.5V
I _{Lim}	Current Limit	-450	-650	-850	mA	Reg = 0V
I _{sink}	Current Sink Capability	220	350	400	mA	Reg = 3.5V
T _{shut}	Thermal Shutdown		150		°C	

Disconnect Section

D _{TH}	Disconnect Threshold (Note 2.)	1.1	1.3	1.7	V	
I _{IL}	Input Leakage Current		90	120	μA	Disconnect = 0V

1. Measured with one output high and all other signal lines open.
2. Not production tested, guaranteed by design.

AC CHARACTERISTICS (Note 3., Reg = 2.85, C_L = 2.2μF, t_r = t_f = 6ns)

Symbol	Parameters	0°C to +70°C	Unit
t _(connect)	Max Connect Time, High Impedance to Termination, Disconnect to Outputs	100	μs
t _(disconnect)	Max Disconnect Time, Termination to High Impedance, Disconnect to Outputs	20	μs

3. Not production tested, guaranteed by design.

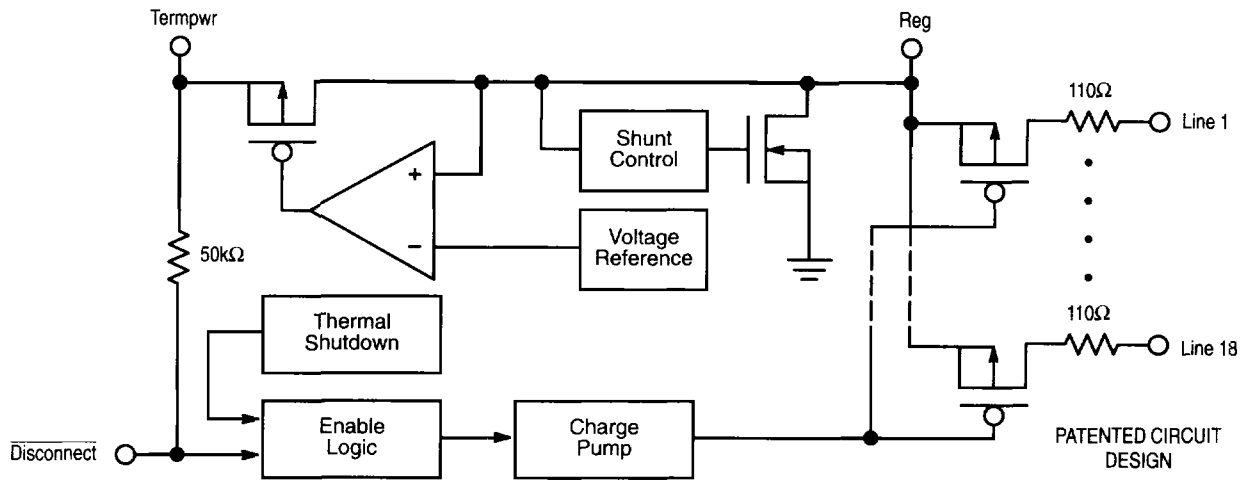

Figure 2. MCCS142238 Block Diagram

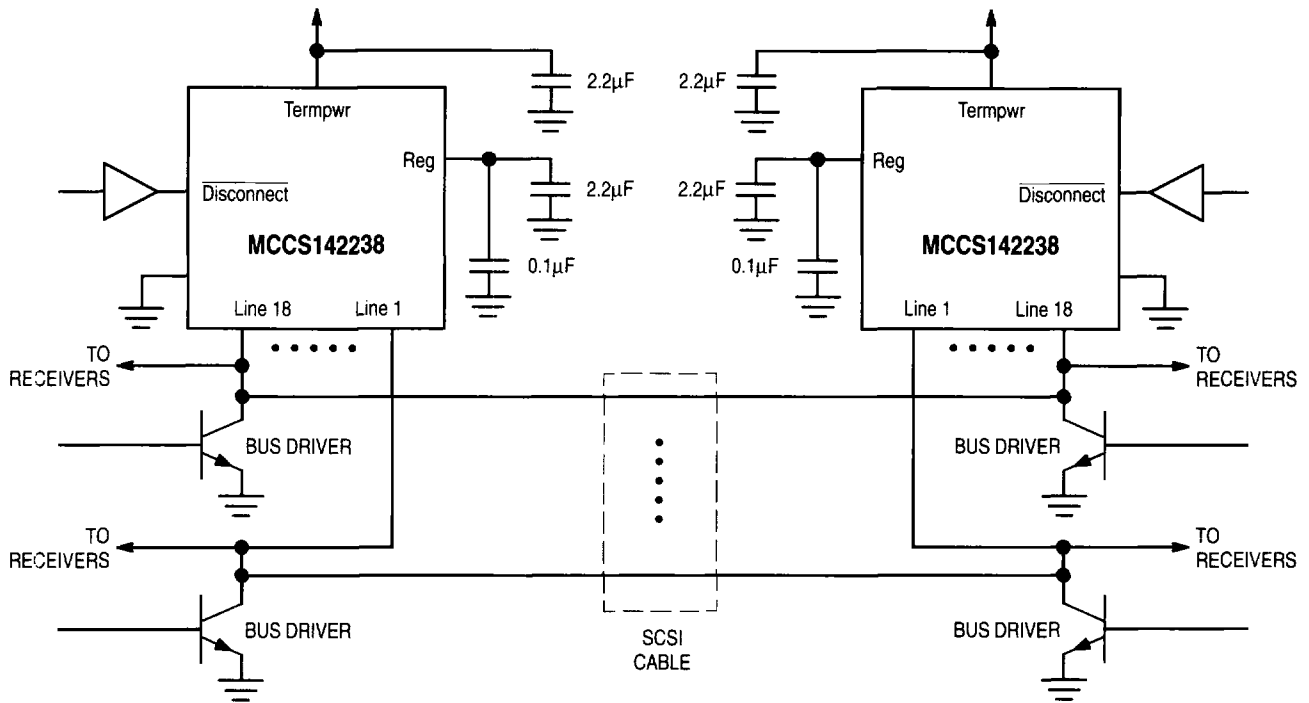

Figure 3. Typical SCSI Bus Configuration Using the MCCS142238

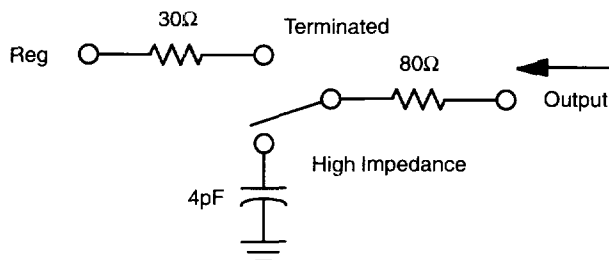

Figure 4. Output Impedance Model