



600 V IL4216  
700 V IL4217  
800 V IL4218

## Triac Optocoupler

### FEATURES

- High Input Sensitivity  $I_{FT}=1.3$  mA
- 600/700/800 V Blocking Voltage
- 300 mA On-State Current
- High Static  $dv/dt$  10,000 V/ $\mu$ sec., typical
- Inverse Parallel SCRs Provide Commutating  $dv/dt >10$  kV/ $\mu$ sec
- Very Low Leakage  $<10$   $\mu$ A
- Isolation Test Voltage from Double Molded Package 5300 V<sub>RMS</sub>
- Package, 6-Pin DIP
- Underwriters Lab File #E52744
-  VDE Approval #0884 Available with Option 1

### DESCRIPTION

The IL421x consists of an AlGaAs IRLLED optically coupled to a pair of photosensitive non-zero crossing SCR chips and are connected inversely parallel to form a TRIAC. These three semiconductors are assembled in a six pin 0.3 inch dual in-line package, using high insulation double molded, over/under leadframe construction.

High input sensitivity is achieved by using an emitter follower phototransistor and a cascaded SCR pre-driver resulting in an LED trigger current of less than 1.3 mA (DC).

The IL421x uses two discrete SCRs resulting in a commutating  $dv/dt$  of greater than 10 kV/ $\mu$ s. The use of a proprietary  $dv/dt$  clamp results in a static  $dv/dt$  of greater than 10 kV/ $\mu$ s. This clamp circuit has a MOS-FET that is enhanced when high  $dv/dt$  spikes occur between MT1 and MT2 of the TRIAC. The FET clamps the base of the phototransistor when conducting, disabling the internal SCR predriver.

The blocking voltage of up to 800 V permits control of off-line voltages up to 240 VAC, with a safety factor of more than two, and is sufficient for as much as 380 VAC. Current handling capability is up to 300 mA RMS, continuous at 25°C.

The IL421x isolates low-voltage logic from 120, 240, and 380 VAC lines to control resistive inductive, or capacitive loads including motors solenoids, high current thyristors or TRIAC and relays.

Applications include solid-state relays, industrial controls, office equipment, and consumer appliances.

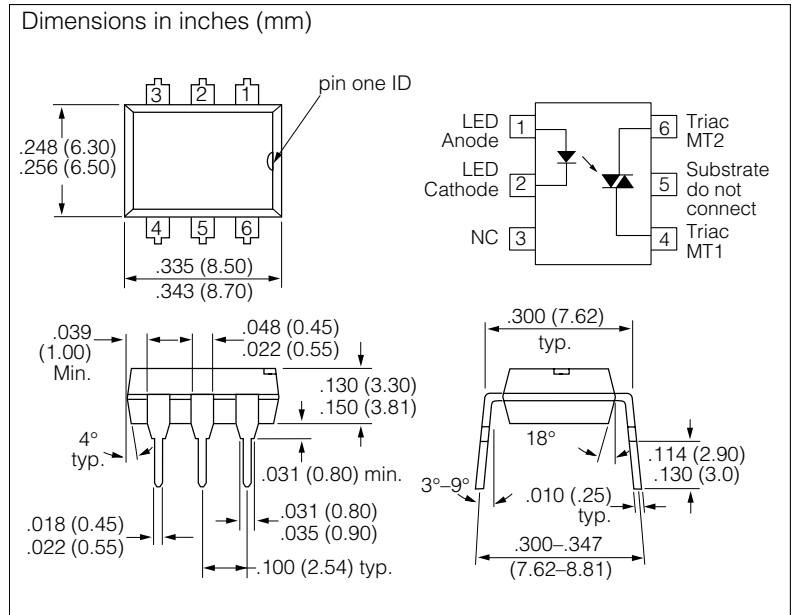

### Maximum Ratings

#### Emitter

Reverse Voltage .....	6.0 V
Forward Current .....	60 mA
Surge Current .....	2.5 A
Power Dissipation .....	100 mW
Derate Linearly from 25°C .....	1.33 mW/°C
Thermal Resistance .....	750 °C/W

#### Detector

Peak Off-State Voltage	
IL4216 .....	600 V
IL4217 .....	700 V
IL4218 .....	800 V
RMS On-State Current .....	300 mA
Single Cycle Surge .....	3.0 A
Total Power Dissipation .....	500 mW
Derate Linearly from 25°C .....	6.6 mW/°C
Thermal Resistance .....	150°C/W

#### Package

Lead Soldering Temperature .....	260°C/5.0 sec.
Creepage Distance .....	$\geq 7.0$ mm
Clearance .....	$\geq 7.0$ mm
Storage Temperature .....	-55°C to +150°C
Operating Temperature .....	-55°C to +100°C
Isolation Test Voltage .....	5300 V <sub>RMS</sub>
Isolation Resistance	
$V_{IO}=500$ V, $T_A=25^\circ$ C .....	$\geq 10^{12}$ $\Omega$
$V_{IO}=500$ V, $T_A=100^\circ$ C .....	$\geq 10^{11}$ $\Omega$

**Characteristics**  $T_A=25^\circ\text{C}$ 

Parameter	Symbol	Min.	Typ.	Max.	Unit	Condition
<b>Emitter</b>						
Forward Voltage	$V_F$	—	1.3	1.5	V	$I_F=20\text{ mA}$
Breakdown Voltage	$V_{BR}$	6.0	30	—	V	$I_R=10\text{ mA}$
Reverse Current	$I_R$	—	0.1	10	$\mu\text{A}$	$V_R=6.0\text{ V}$
Capacitance	$C_O$	—	40	—	pF	$V_F=0\text{ V}$ , $f=1.0\text{ MHz}$
Thermal Resistance, Junction to Lead	$R_{THJL}$	—	750	—	K/W	—
<b>Output Detector</b>						
Repetitive Peak Off-State Voltage IL4216 IL4217 IL4218	$V_{DRM}$ $V_{DRM}$ $V_{DRM}$	600 700 800	650 750 850	—	V V V	$I_{DRM}=100\ \mu\text{A}$ $I_{DRM}=100\ \mu\text{A}$ $I_{DRM}=100\ \mu\text{A}$
Off-State Voltage IL4216 IL4217 IL4218	$V_{D(RMS)}$ $V_{D(RMS)}$ $V_{D(RMS)}$	424 484 565	460 536 613	—	V V V	$I_{D(RMS)}=70\ \mu\text{A}$ $I_{D(RMS)}=70\ \mu\text{A}$ $I_{D(RMS)}=70\ \mu\text{A}$
Off-State Current	$I_{D(RMS)}$	—	10	100	$\mu\text{A}$	$V_D=600\text{ V}$ , $T_A=100^\circ\text{C}$
Reverse Current	$I_{R(RMS)}$	—	10	100	$\mu\text{A}$	$V_R=600\text{ V}$ , $T_A=100^\circ\text{C}$
On-State Voltage	$V_{TM}$	—	1.7	3.0	V	$I_T=300\text{ mA}$
On-State Current	$I_{TM}$	—	—	300	mA	PF=1.0, $V_{T(RMS)}=1.7\text{ V}$
Surge (Non-Repetitive) On-State Current	$I_{TSM}$	—	—	3.0	A	f=50 Hz
Holding Current	$I_H$	—	65	200	$\mu\text{A}$	$V_T=3.0\text{ V}$
Latching Current	$I_L$	—	5.0	—	mA	$V_T=2.2\text{ V}$
LED Trigger Current	$I_{FT}$	—	0.7	1.3	mA	$V_{AK}=5.0\text{ V}$
Turn-On Time	$t_{ON}$	—	35	—	$\mu\text{s}$	$V_{RM}=V_{DM}=424\text{ VAC}$
Turn-Off Time	$t_{OFF}$	—	50	—	$\mu\text{s}$	PF=1.0, $I_T=300\text{ mA}$
Critical State of Rise of Off-State Voltage	$dv/dt_{cr}$	10000	—	—	V/ $\mu\text{s}$	$V_D=0.67 V_{DRM}$ , $T_j=25^\circ\text{C}$
		5000	—	—		$V_D=0.67 V_{DRM}$ , $T_j=80^\circ\text{C}$
Critical Rate of Rise of Voltage at Current Commutation	$dv/dt_{crq}$	10000	—	—	V/ $\mu\text{s}$	$V_D=0.67 V_{DRM}$ , $di/dt_{crq}\leq 15\text{ A/ms}$ $T_j=25^\circ\text{C}$
		5000	—	—		$V_D=0.67 V_{DRM}$ , $di/dt_{crq}\leq 15\text{ A/ms}$ $T_j=80^\circ\text{C}$
Off-State Current	$di/dt$	—	100	—	A/ms	$I_T=300\text{ mA}$
Thermal Resistance, Junction to Lead	$R_{THJL}$	—	150	—	K/W	—
<b>Package</b>						
Critical Rate of Rise of Coupled Input-Output Voltage	$dv_{(IO)}/dt$	5000	—	—	V/ $\mu\text{s}$	$I_T=0\text{ A}$ , $V_{RM}=V_{DM}=300\text{ VAC}$
Common Mode Coupling Capacitor	$C_{CM}$	—	0.01	—	pF	—
Package Capacitance	$C_{IO}$	—	0.8	—	pF	f=1.0 MHz, $V_{IO}=0\text{ V}$

Figure 1. LED forward current vs. forward voltage

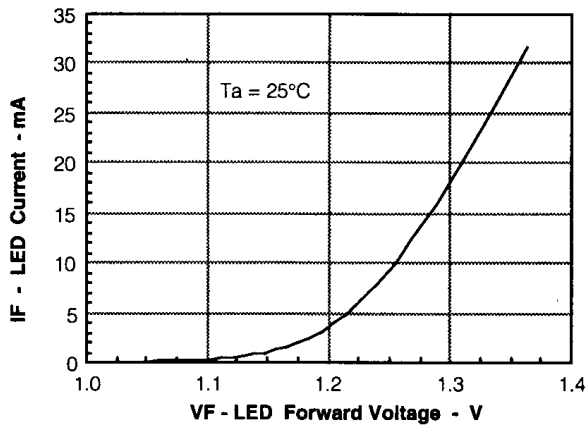

Figure 4. Maximum LED power dissipation

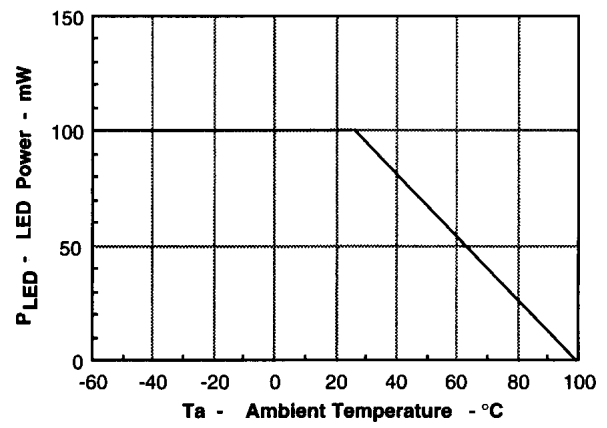

Figure 2. Forward voltage versus forward current

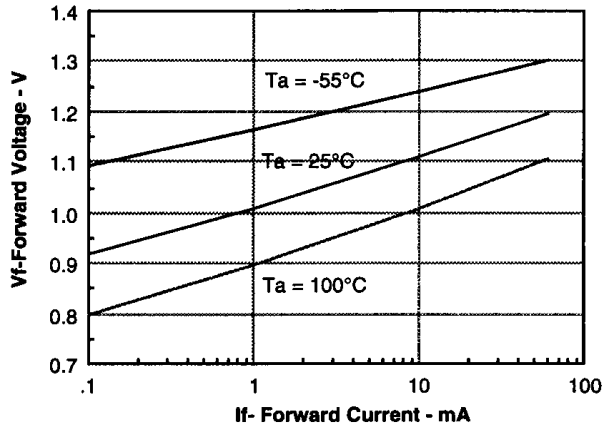

Figure 5. On-state terminal voltage vs. terminal current

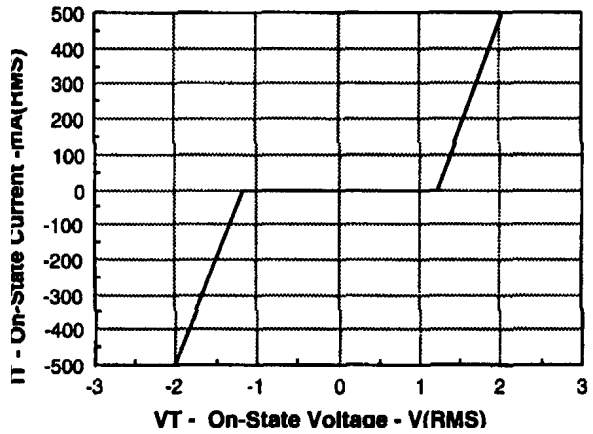

Figure 3. Peak LED current vs. duty factor, Tau

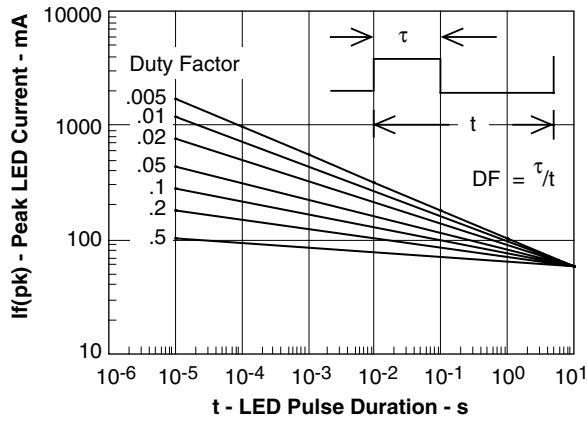
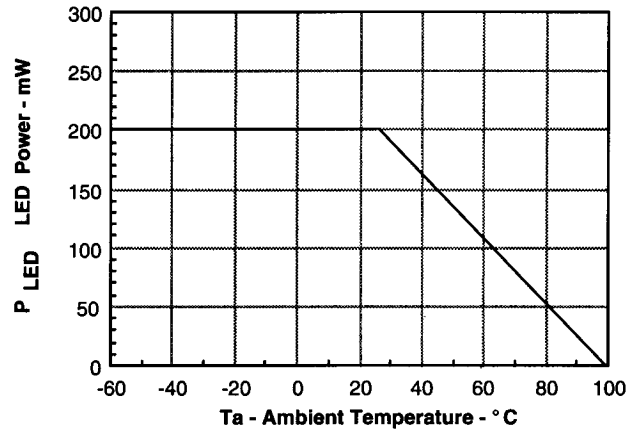

Figure 6. Maximum output power dissipation



## Power Factor Considerations

A snubber isn't needed to eliminate false operation of the TRIAC driver because of the IL411's high static and commutating dv/dt with loads between 1 and 0.8 power factors. When inductive loads with power factors less than 0.8 are being driven, include a RC snubber or a single capacitor directly across the device to damp the peak commutating dv/dt spike. Normally a commutating dv/dt causes a turning-off device to stay on due to the stored energy remaining in the turning-off device.

But in the case of a zero voltage crossing optotriac, the commutating dv/dt spikes can inhibit one half of the TRIAC from turning on. If the spike potential exceeds the inhibit voltage of the zero cross detection circuit, half of the TRIAC will be held-off and not turn-on. This hold-off condition can be eliminated by using a snubber or capacitor placed directly across the optotriac as shown in Figure 7. Note that the value of the capacitor increases as a function of the load current.

The hold-off condition also can be eliminated by providing a higher level of LED drive current. The higher LED drive provides a larger photocurrent which causes the phototransistor to turn-on before the commutating spike has activated the zero cross network. Figure 8 shows the relationship of the LED drive for power factors of less than 1.0. The curve shows that if a device requires 1.5 mA for a resistive load, then 1.8 times (2.7 mA) that amount would be required to control an inductive load whose power factor is less than 0.3.

Figure 7. Shunt capacitance versus load current versus power factor

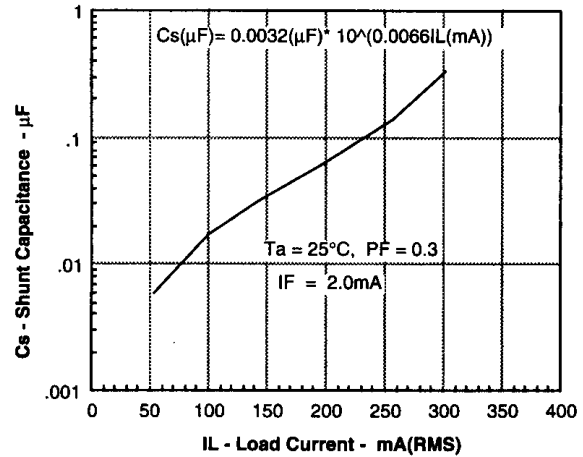

Figure 8. Normalized LED trigger current versus power factor

