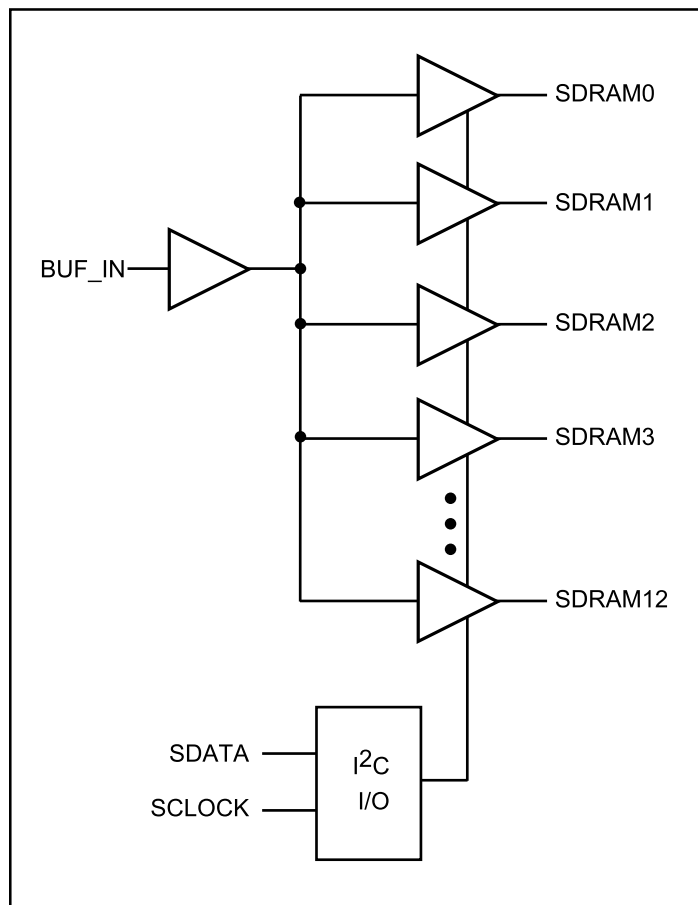

Precision 1-13 Clock Buffer
Product Features

- High speed, to 133 MHz
- Low noise non-inverting 1-13 buffer
- Supports up to four SDRAM DIMMs
- Low skew (< 250ps) between any two output clocks
- I²C Serial Configuration interface
- Multiple V_{DD}, V_{SS} pins for noise reduction
- 3.3V power supply voltage
- Separate Hi-Z pin for testing
- Package: 28-pin SSOP packages (H)

Block Diagram

Description

The PI6C184B, a high-speed low-noise 1-13 non-inverting buffer designed for SDRAM clock buffer applications, is intended to be used with the PI6C104 clock generator for Intel Architecture for both desktop and mobile systems.

At power up, all SDRAM outputs are enabled and active. The I²C Serial control may be used to individually activate/deactivate any of the 13 output drivers.

Note:

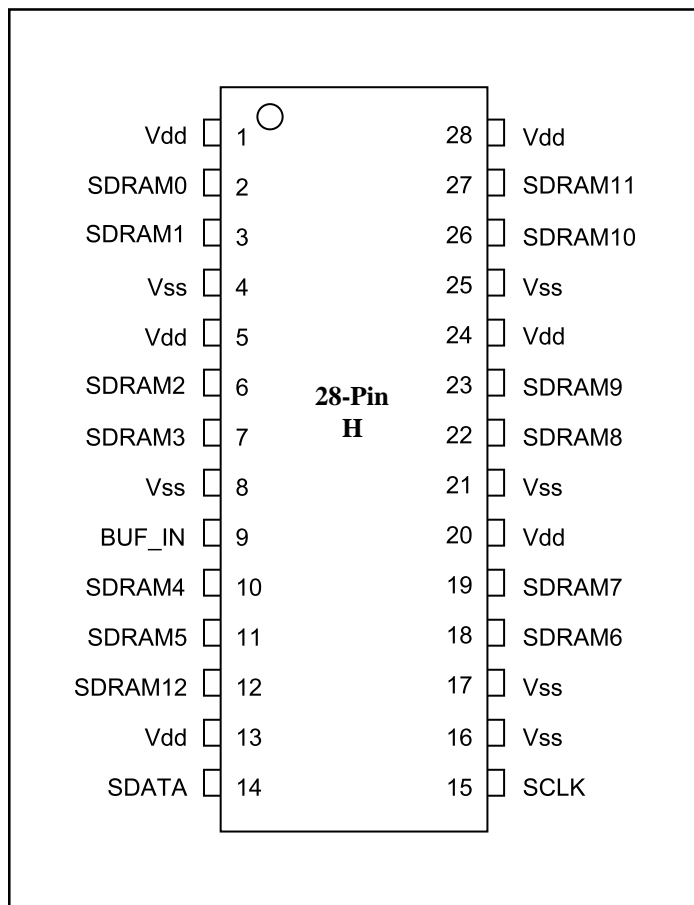
Purchase of I²C components from Pericom conveys a license to use them in an I²C system as defined by Philips.

Pin Configuration

Pin Description

Pin	Symbol	Type	Quantity	Description
2,3,6,7,10,11,18,19	SDRAM [0.7]	0	8	SDRAM Byte 0 clock output
26,27,12	SDRAM [10.12]	0	3	SDRAM Byte 1 clock output
22,23	SDRAM [8.9]	0	2	SDRAM Byte 2 clock output
9	BUF_IN	1	1	Input for 1-13-buffer
14	SDATA	I/O	1	Data pin for I ² C circuitry. Has a 100k Internal pull-up resistor
154	SCLOCK	I/O	1	Clock pin for I ² C circuitry. Has a 100k Internal pull-up resistor
1,5,13,20,24,28	V _{DD}	Power	6	3.3V power supply for SDRAM buffer
4,8,16,17,21,25	V _{SS}	Ground	6	Ground for SDRAM Buffers

PI6C184B Serial Configuration Map

Byte0: SDRAM Active/Inactive Register
(1 = enable, 0 = disable)

Bit	Pin #	Description
Bit 7	19	SDRAM7 (Active/Inactive)
Bit 6	18	SDRAM6 (Active/Inactive)
Bit 5	11	SDRAM5 (Active/Inactive)
Bit 4	10	SDRAM4 (Active/Inactive)
Bit 3	7	SDRAM3 (Active/Inactive)
Bit 2	6	SDRAM2 (Active/Inactive)
Bit 1	3	SDRAM1 (Active/Inactive)
Bit 0	2	SDRAM0 (Active/Inactive)

PI6C184B I²C Address Assignment

A6	A5	A4	A3	A2	A1	A0	R/W
1	1	0	1	0	0	1	0

Note:

Inactive means outputs are held LOW and are disabled from switching

2-Wire I²C Control

The I²C interface permits individual enable/disable of each clock output and test mode enable.

The PI6C184B is a slave receiver device. It can not be read back. Sub addressing is not supported. To change one of the control bytes, all preceding bytes must be sent

Every byte put on the SDATA line must be 8-bits long (MSB first), followed by an acknowledge bit generated by the receiving device. During normal data transfers SDATA changes only when SCLK is LOW. Exceptions: A HIGH to LOW transition on SDATA while SCLK is HIGH indicates a “start” condition; a LOW to HIGH transition on SDATA while SCLK is HIGH is a “stop” condition and indicates the end of a data transfer cycle.

Each data transfer is initiated with a start condition and ended with a stop condition. The first byte after a start condition is always a 7-bit address byte followed by a read/write bit. (HIGH = read from addressed device, LOW = write to addressed device). If the device’s own address is detected, PI6C184B generates an acknowledge by pulling SDATA line LOW during ninth clock pulse, then accepts the following data bytes until another start or stop condition is detected.

Following acknowledgement of the address byte (D2), two more bytes must be sent:

1. “Command Code” byte & 2. “Byte Count” byte.

Although the data bits on these two bytes are “don’t care,” they must be sent and acknowledged.

Byte1: SDRAM Active/Inactive Register (1 = enable, 0 = disable)

Bit	Pin #	Description
Bit 7		NC (Initialize to 0)
Bit 6		NC (Initialize to 0)
Bit 5		NC (Initialize to 0)
Bit 4		NC (Initialize to 0)
Bit 3		NC (Initialize to 0)
Bit 2	12	SDRAM12 (Active/Inactive)
Bit 1	27	SDRAM11 (Active/Inactive)
Bit 0	26	SDRAM10 (Active/Inactive)

Byte2: Optional Register for Possible Future Requirements (1 = enable, 0 = disable)

Bit	Pin #	Description
Bit 7	23	SDRAM9 (Active/Inactive)
Bit 6	22	SDRAM8 (Active/Inactive)
Bit 5	-	(Reserved)
Bit 4	-	(Reserved)
Bit 3	-	(Reserved)
Bit 2	-	(Reserved)
Bit 1	-	(Reserved)
Bit 0	-	(Reserved)

Maximum Ratings

(Above which useful life may be impaired. For user guidelines, not tested.)

Storage Temperature	-65°C to +150°C
Ambient Temperature with Power Applied	-0°C to +70°C
3.3V Supply Voltage to Ground Potential	-0.5V to +4.6V
DC Input Voltage	-0.5V to +4.6V

Note:

Stresses greater than those listed under MAXIMUM RATINGS may cause permanent damage to the device. This is a stress rating only and functional operation of the device at these or any other conditions above those indicated in the operational sections of this specification is not implied. Exposure to absolute maximum rating conditions for extended periods may affect reliability.

Supply Current (V_{DD} = +3.465V, C_{LOAD} = Max.)

Symbol	Parameter	Test Condition	Min.	Typ.	Max.	Units
I _{DD}	Supply Current	BUF_IN = 0 MHz			3	mA
I _{DD}	Supply Current	BUF_IN = 66.66 MHz			230	
I _{DD}	Supply Current	BUF_IN = 100.0 MHz			360	

DC Operating Specifications ($V_{DD} = +3.3V \pm 5\%$, $T_A = 0^\circ C - 70^\circ C$)

Symbol	Parameter	Test Condition	Min.	Max.	Units
Input Voltage					
V_{IH}	Input high voltage	V_{DD}	2.0	$V_{DD}+0.3$	V
V_{IL}	Input low voltage		$V_{SS}-0.3$	0.8	
I_{IL}	Input leakage current	$0 < V_{IN} < V_{DD}$	-5	+5	mA
$V_{DD}[0-9] = 3.3V \pm 5\%$					
V_{OH}	Output high voltage	$I_{OH} = -1mA$	2.4		V
V_{OL}	Output low voltage	$I_{OL} = 1mA$		0.4	
C_{OUT}	Output pin capacitance			6	pF
C_{IN}	Input pin capacitance			5	
L_{PIN}	Pin Inductance			7	nH
T_A	Ambient Temperature	No Airflow	0	70	$^\circ C$

SDRAM Clock Buffer Operating Specification

Symbol	Parameter	Test Conditions	Min.	Typ.	Max.	Units
I_{OHMIN}	Pull-up current	$V_{OUT} = 2.0V$	-40			mA
I_{OHMAX}	Pull-up current	$V_{OUT} = 3.135V$			36	
I_{OLMIN}	Pull-down current	$V_{OUT} = 1.0V$	40			
I_{OLMAX}	Pull-down current	$V_{OUT} = 0.4V$			38	
$t_{RHSDRAM}$	Output rise edge rate SDRAM only	$3.3V \pm 5\%$ @04V-2.4V	1.5		4	V/ns
$t_{THSDRAM}$	Output fall edge rate SDRAM only	$3.3V \pm 5\%$ @2.4V-0.4V	1.5		4	

ACTiming

Symbol	Parameter	66 MHz		100 MHz		133 MHz		Units
		Min.	Max.	Min.	Max.	Min.	Max.	
t_{SDKP}	SDRAM CLK period	15.0	15.5	10.0	10.5	7.5	7.8	ns
t_{SDKH}	SDRAM CLK high time	5.6		3.3		1.0		
t_{SDKL}	SDRAM CLK low time	5.3		3.1		1.0		
t_{SDRISE}	SDRAM CLK rise time	1.5	4.0	1.5	4.0	1.5	4.0	V/ns
t_{SDFALL}	SDRAM CLK fall time	1.5	4.0	1.5	4.0	1.5	4.0	
t_{PLH}	SDRAM Buffer LH prop delay	1.0	5.5	1.0	5.5	1.0	5.5	ns
t_{PHL}	SDRAM Buffer HL prop delay	1.0	5.5	1.0	5.5	1.0	5.5	
t_{PZL}, t_{PZH}	SDRAM Buffer Enable delay	1.0	8.0	1.0	8.0	1.0	8.0	
t_{PLZ}, t_{PHZ}	SDRAM Buffer Disable delay	1.0	8.0	1.0	8.0	1.0	8.0	
Duty Cycle	Measured at 1.5V	45	55	45	55	45	55	%
t_{SDSKW}	SDRAM Output to Output Skew		250		250		250	ps

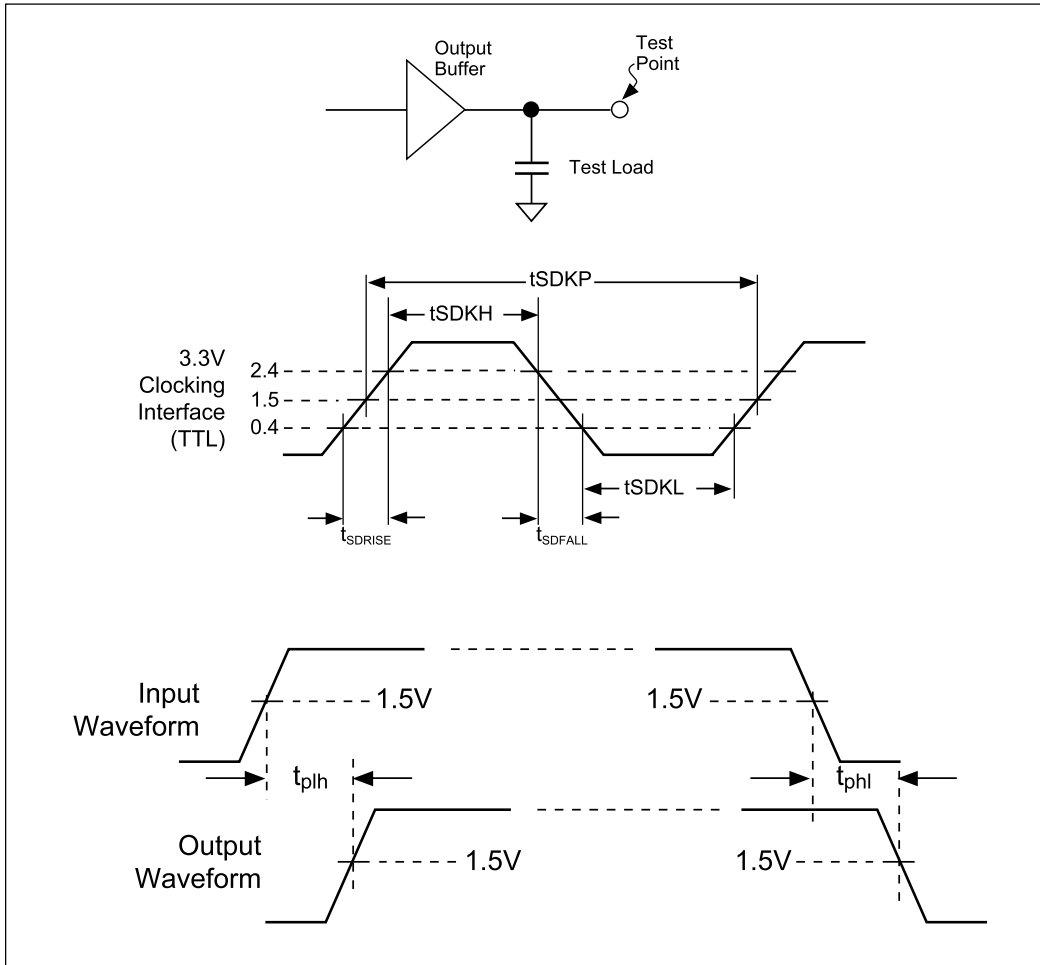

Figure 1. Clock Waveforms

Minimum and Maximum Expected Capacitive Loads

Clock	Min. Load	Max. Load	Units	Notes
SDRAM	15	20	pF	SDRAM DIMM Specification

Notes:

1. Maximum rise/fall times are guaranteed at maximum specified load.
2. Minimum rise/fall times are guaranteed at minimum specified load.
3. Rise/fall times are specified with pure capacitive load as shown.
Testing is done with an additional 500Ω resistor in parallel.

Design Guidelines to Reduce EMI

1. Place series resistors and CI capacitors as close as possible to the respective clock pins. Typical value for CI is 10pF. Series resistor value can be increased to reduce EMI provided that the rise and fall time are still within the specified values.
2. Minimize the number of “vias” of the clock traces.
3. Route clock traces over a continuous ground plane or over a continuous power plane. Avoid routing clock traces from plane to plane (refer to rule #2).
4. Position clock signals away from signals that go to any cables or any external connectors.

PCB Layout Suggestion

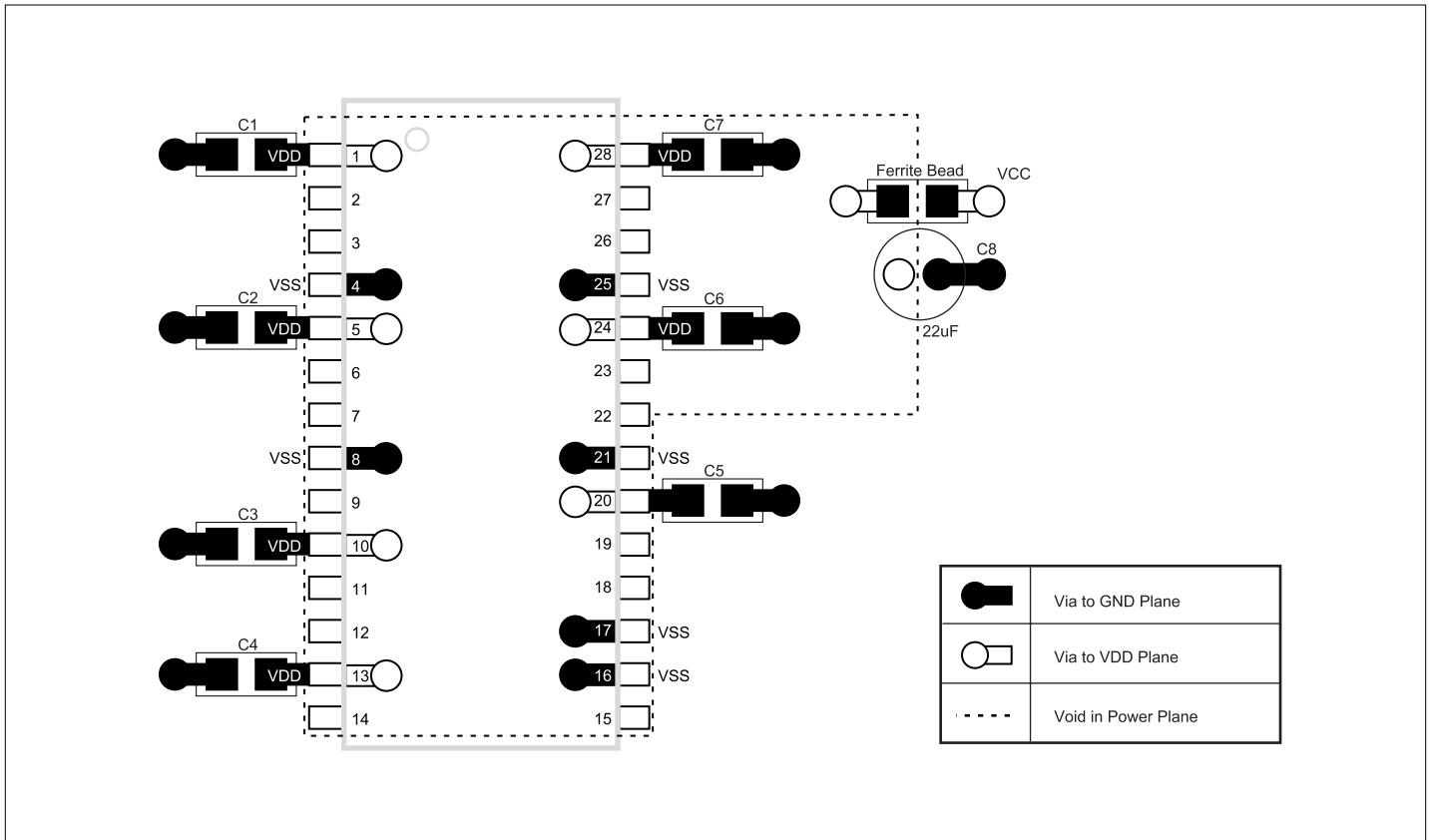

Note:

This is only a suggested layout. There may be alternate solutions depending on actual PCB design and layout. As a general rule, C1-C7 should be placed as close as possible to their respective V_{DD} .

Recommended capacitor values:
 C1-C7 0.1 μ F, ceramic
 C8 22 μ F

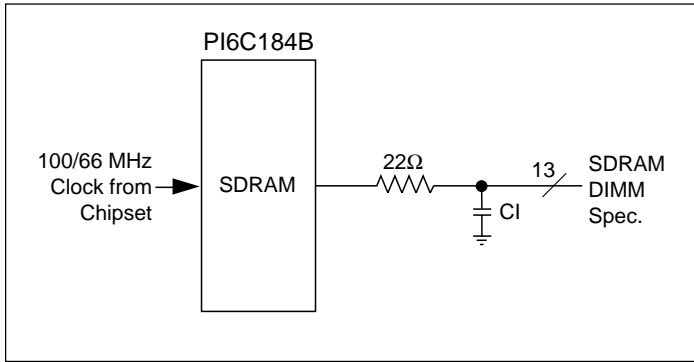

Figure 2. Design Guidelines

28-Pin SSOP (H) Package

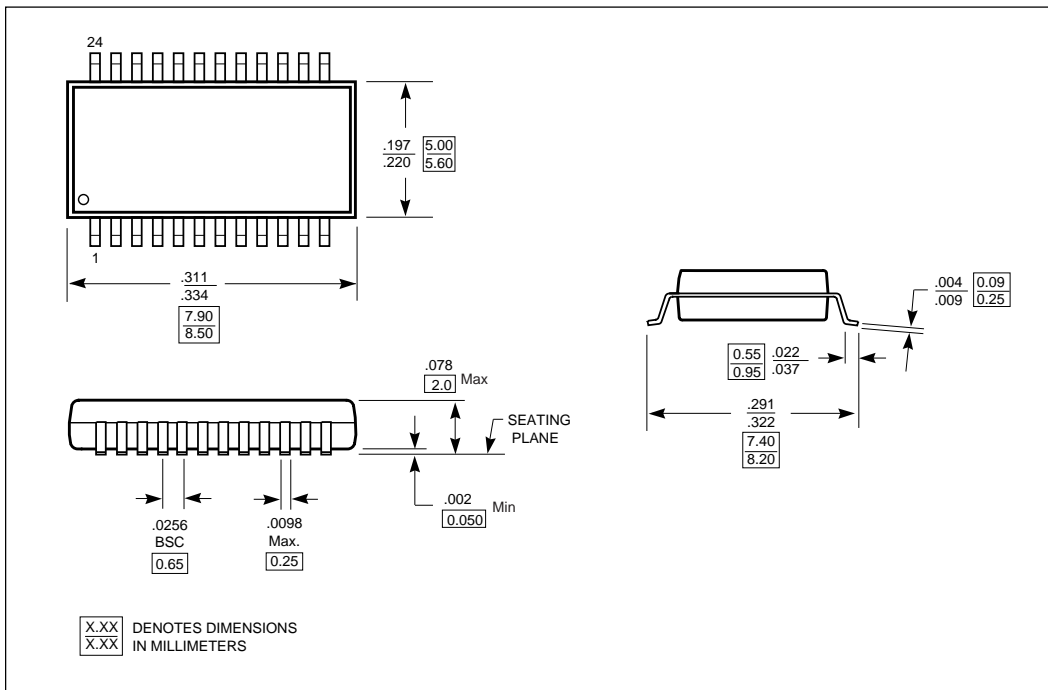

Table of Dimensions

Body		E (Width)	D (Length)	A (Height)	e (Pin-to-Pin pitch)
28 pins	Min.	0.205	0.397	0.068	0.025
(20g)	Max.	0.210	0.407	0.078	-

Ordering Information

P/N	Description
PI6C184BH	SSOP Package