

Integrated Device Technology, Inc.

**FOURTH GENERATION
64-BIT RISC
MICROPROCESSOR**

**ORION
IDT79R4600**

FEATURES:

- True 64-bit microprocessor
 - 64-bit integer operations
 - 64-bit floating-point operations
 - 64-bit registers
 - 64-bit virtual address space
- High-performance microprocessor
 - 100 peak MIPS at 100MHz
 - 33 peak MFLOP/s at 100MHz
 - 68 SPECint92 at 100Mz
 - Two-way set associative caches
- High level of integration
 - 64-bit integer CPU
 - 64-bit floating-point unit
 - 16KB instruction cache; 16KB data cache
 - Flexible MMU with large TLB
- Low-power operation
 - 3.3V or 5V power supply options
 - 25mW/MHz internal power dissipation (2.5W @ 100MHz, 3.3V)
 - Standby mode reduces internal power to 60mW

- Standard operating system support includes:
 - Microsoft Windows™ NT
 - UNISOFT Unix™ System V.4
- Fully software compatible with R4000 RISC Processor Family
- Available in R4000PC/R4400PC pin-compatible 179-pin PGA or 208-pin MQUAD
- 50MHz input and output clock frequency
 - On-chip clock doubler for 100MHz pipeline
- 64GB physical address space
- Processor family for a wide variety of applications
 - Desktop workstations and PCs
 - Deskside or departmental servers
 - High-performance embedded applications (e.g. color printers, multi-media and internetworking.)
 - Notebooks

DESCRIPTION:

The IDT79R4600™ supports a wide variety of processor-based applications, from 32-bit Windows NT desktop or notebook systems through high-performance, 64-bit OLTP

BLOCK DIAGRAM:

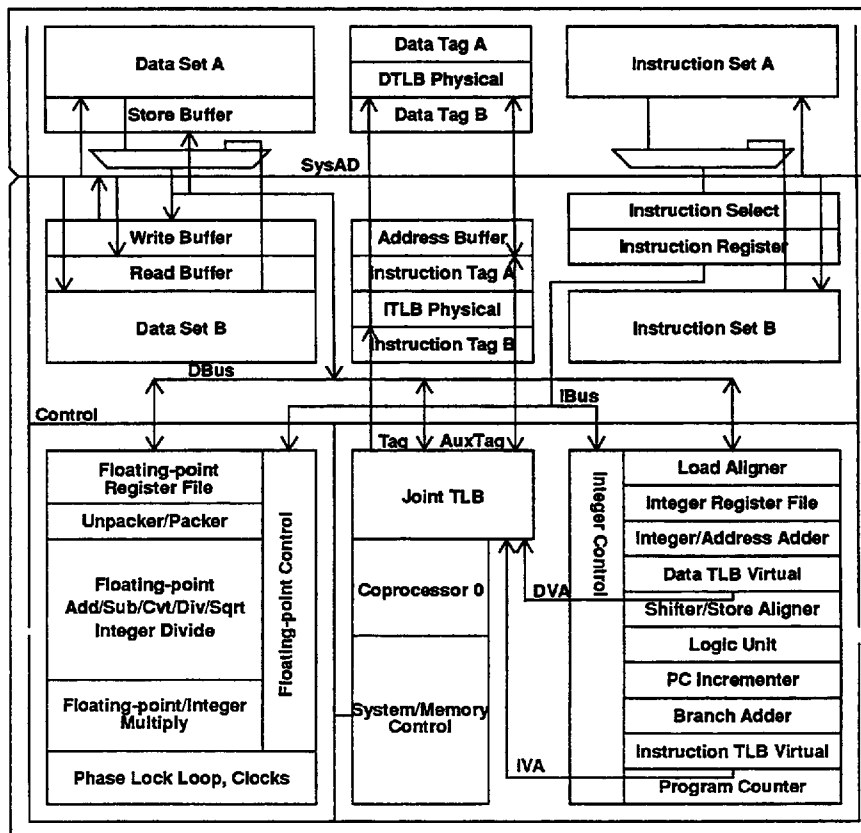

3038 drw 01

The IDT logo is a registered trademark and Orion, R4600 and R4400 are trademarks of Integrated Device Technology, Inc.

COMMERCIAL TEMPERATURE RANGE

SEPTEMBER 1993

systems. Compatible with the IDT79R4000PC family for both hardware and software, the R4600 will serve in many of the same applications, but, in addition supports low-power operation for applications such as "green" desktops and notebook computers. It does not provide integrated secondary cache and multiprocessor support as found in the R4000SC and R4000MC, but an external secondary cache can lastly be designed around it. The large on-chip two-way set associative caches make this unnecessary in most embedded control applications.

The R4600 brings R4000SC performance levels to the R4000PC package, while at the same time providing lower cost and lower power. It does this by providing larger on-chip caches that are two-way set associative, fewer pipeline stalls, and early restart for data cache misses. The result is 68 SPECint92 and >60SPECfp92 (exact figures are system-dependent).

The R4600 provides complete upward application-software compatibility with the IDT79R3000 family of microprocessors, including the IDT RISController™ family (the IDT79R3001 and IDT79R3051 family) as well as the IDT79R4000/4400 family of microprocessors. Microsoft Windows NT and UNISOFT UnixUnix V.4 operating systems insure the availability of thousands of applications programs, geared to provide a complete solution to a large number of processing needs. An array of development tools facilitates the rapid development of R4600-based systems, enabling a wide variety of customers to take advantage of the MIPS Open Architecture philosophy.

Together with the R4000 family, the R4600 provides a compatible, timely, and necessary evolution path from 32-bit to true, 64-bit computing. The original design objectives of the R4000 clearly mandated this evolution path; the result is a true 64-bit processor fully compatible with 32-bit operating systems and applications.

The 64-bit computing and addressing capability of the R4600 enables a wide variety of capabilities previously limited by a smaller address space. For example, the large

address space allows operating systems with extensive file mapping; direct access to large files can occur without explicit I/O calls. Applications such as large CAD databases, multi-media, and high-quality image storage and retrieval all directly benefit from the enlarged address space.

This data sheet provides an overview of the features and architecture of the R4600 CPU. A more detailed description of the processor is available in the "R4600 User's Manual", available from IDT. Further information on development support, applications notes, and complementary products are also available from your local IDT sales representative.

HARDWARE OVERVIEW

The R4600 family brings a high-level of integration designed for high-performance computing. The key elements of the R4600 are briefly described below. A more detailed description of each of these subsystems is available in the User's Manual.

Pipeline

The R4600 uses a 5-stage pipeline similar to the IDT79R3000. The simplicity of this pipeline allows the R4600 to be lower cost and lower power than super-scalar or super-pipelined processors. Unlike the R3000, the R4600 does virtual-to-physical translation in parallel with cache access. This allows the R4600 to operate at twice the frequency of the R3000 and to support a larger TLB for address translation.

Compared to the 8-stage R4000 pipeline, the R4600 is more efficient (requires fewer stalls).

Figure 2 shows the R4600 pipeline.

Integer Execution Engine

The R4600 implements the MIPS Instruction Set architecture, and thus is fully upward compatible with applications running on the earlier generation parts. The R4600 includes the same additions to the instruction set as found

Figure 1. CPU Registers

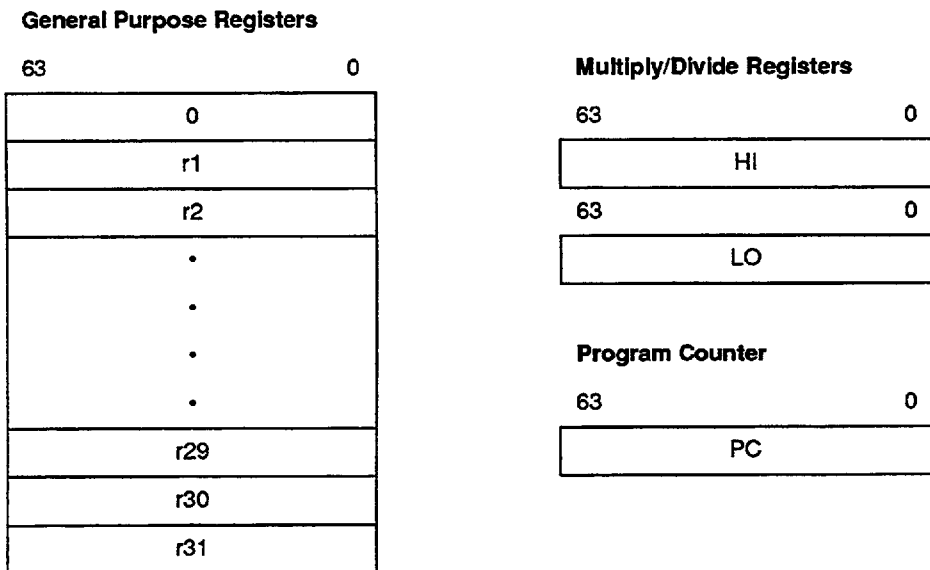
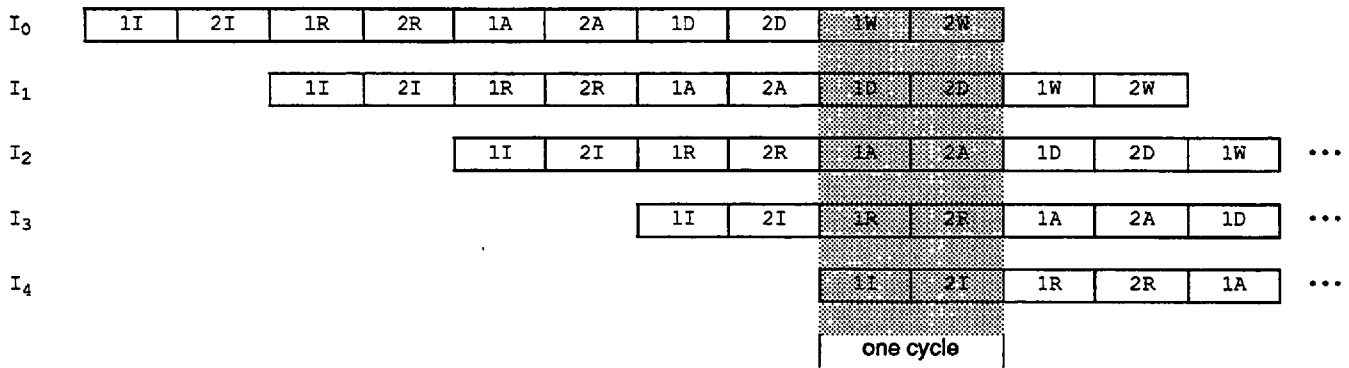

Figure 2. R4600 Pipeline



- 1I-1R Instruction cache access
- 2I Instruction virtual to physical address translation in ITLB
- 2A-2D Data cache access and load align
- 1D Data virtual to physical address translation in DTLB
- 1D-2D Virtual to physical address translation in JTLB
- 2R Register file read
- 2R Bypass calculation
- 2R Instruction decode
- 2R Branch address calculation
- 1A Issue or slip decision
- 1A-2A Integer add, logical, shift
- 1A Data virtual address calculation
- 2A Store align
- 1A Branch decision
- 2W Register file write

in the R4000 family of microprocessors, targeted at improving performance and capability while maintaining binary compatibility with earlier processors. The extensions result in better code density, greater multi-processing support, improved performance for commonly used code sequences in operating system kernels, and faster execution of floating-point intensive applications. All resource dependencies are made transparent to the programmer, insuring transportability amongst implementations of the MIPS instruction set architecture.

In addition to the instruction extensions detailed above, new instructions have been defined to take advantage of the 64-bit architecture of the processor. When operating as a 32-bit processor, the R4600 will take an exception on these new instructions.

The MIPS integer unit implements a load/store architecture with single cycle ALU operations (logical, shift, add, sub) and autonomous multiply/divide unit. The register resources include: 32 general purpose orthogonal integer registers, the HI/LO result registers for the integer multiply/divide unit, and the program counter. In addition, the on-chip floating-point co-processor adds 32 floating-point registers, and a floating-point control/status register.

Register File

The R4600 has thirty-two general-purpose registers. These registers are used for scalar integer operations and

address calculation. The register file consists of two read ports and one write port, and is fully bypassed to minimize operation latency in the pipeline.

ALU

The R4600 ALU consists of the integer adder and logic unit. The adder performs address calculations in addition to arithmetic operations, and the logic unit performs all logical and shift operations. Each of these units is highly optimized and can perform an operation in a single pipeline cycle.

Integer Multiply/Divide

The R4600 uses the floating-point unit to perform integer multiply and divide. The results of the operation are placed in the HI and LO registers. The values can then be transferred to the general purpose register file using the MFHI/MFLO instructions. Table 1 below shows the number of processor internal cycles required between an integer multiply or divide and a subsequent MFHI or MFLO operation, in order that no interlock or stall occurs.

Table 1: Integer multiply/divide cycles

	32-bit	64-bit
MULT	10	12

Table 1: Integer multiply/divide cycles

	32-bit	64-bit
DIV	42	74

Floating-Point Co-Processor

The R4600 incorporates an entire floating-point co-processor on chip, including a floating-point register file and execution units. The floating-point co-processor forms a "seamless" interface with the integer unit, decoding and executing instructions in parallel with the integer unit.

Floating-Point Units

The R4600 floating-point execution units supports single and double precision arithmetic, as specified in the IEEE Standard 754. The execution unit is broken into a separate multiply unit and a combined add/convert/divide/square root unit. Overlap of multiplies and add/subtract is supported. The multiplier is partially pipelined, allowing a new multiply to begin every 6 cycles.

As in the IDT79R3010 and IDT79R4000, the R4600 maintains fully precise floating-point exceptions while allowing both overlapped and pipelined operations. Precise exceptions are extremely important in mission-critical environments, such as ADA, and highly desirable for debugging in any environment.

The floating-point unit's operation set includes floating-point add, subtract, multiply, divide, square root, conversion between fixed-point and floating-point format, conversion among floating-point formats, and floating-point compare. These operations comply with the IEEE Standard 754.

Table 2 below gives the latencies of some of the floating-point instructions in internal processor cycles.

Table 2: Floating-Point Cycles

Operation	Single Precision	Double Precision
ADD	4	4
SUB	4	4
MUL	8	8
DIV	32	61
SQRT	31	60
CMP	3	3
FIX	4	4
FLOAT	6	6
ABS	1	1
MOV	1	1
NEG	1	1

Table 2: Floating-Point Cycles

Operation	Single Precision	Double Precision
LWC1, LDC1	2	2
SWC1, SDC1	1	1

Floating-Point General Register File

The floating-point register file is made up of thirty-two 64-bit registers. With the LDC1 and SDC1 instructions the floating-point unit can take advantage of the 64-bit wide data cache and issue a co-processor load or store double-word instruction in every cycle.

The floating-point control register space contains two registers; one for determining configuration and revision information for the coprocessor and one for control and status information. These are primarily involved with diagnostic software, exception handling, state saving and restoring, and control of rounding modes.

System Control Co-processor (CP0)

The system control co-processor in the MIPS architecture is responsible for the virtual memory sub-system, the exception control system, and the diagnostics capability of the processor. In the MIPS architecture, the system control co-processor (and thus the kernel software) is implementation dependent. The R4600 CP0 is essentially identical to that of the R4000PC, except that the WatchLo and WatchHi registers are no longer present and the Index CACHE ops use an extra address bit to select one of the two sets (the R4000 caches are direct mapped, instead of two-way set associative).

The Memory management unit controls the virtual memory system page mapping. It consists of an instruction address translation buffer (the ITLB), a data address translation buffer (the DTLB), a Joint TLB (the JTLB), and co-processor registers used for the virtual memory mapping sub-system.

System Control Co-Processor Registers

The R4600 incorporates all system control co-processor (CP0) registers on-chip. These registers provide the path through which the virtual memory system's page mapping is examined and changed, exceptions are handled, and operating modes are controlled (kernel vs. user mode, interrupts enabled or disabled, cache features). In addition, the R4600 includes registers to implement a real-time cycle counting facility, to aid in cache diagnostic testing, and to assist in data error detection.

Figure 5 shows the CP0 registers.

Virtual to Physical Address Mapping

The R4600 provides three modes of virtual addressing:

- user mode
- supervisor mode

• kernel mode

This mechanism is available to system software to provide a secure environment for user processes. Bits in a status register determine which virtual addressing mode is used. In the user mode, the R4600 provides a single, uniform virtual address space of 256GB (2GB for 32-bit mode).

When operating in the kernel mode, four distinct virtual address spaces, totalling 1024GB (4GB in 32-bit mode), are simultaneously available and are differentiated by the high-order bits of the virtual address.

The R4600 processors also support a supervisor mode in which the virtual address space is 256.5GB (2.5GB in 32-bit mode), divided into three regions based on the high-order bits of the virtual address.

Figure 4 shows the address space layout for 32-bit operation.

When the R4600 is configured as a 64-bit microprocessor, the virtual address space layout is an upward compatible extension of the 32-bit virtual address space layout.

Joint TLB

For fast virtual-to-physical address decoding, the R4600 uses a large, fully associative TLB which maps 96 Virtual pages to their corresponding physical addresses. The TLB is organized as 48 pairs of even-odd entries, and maps a virtual address and address space identifier into the large, 64GB physical address space.

Two mechanisms are provided to assist in controlling the amount of mapped space, and the replacement characteristics of various memory regions. First, the page size can be configured, on a per-entry basis, to map a page size of 4KB to 16MB (in multiples of 4). A CP0 register is loaded

with the page size of a mapping, and that size is entered into the TLB when a new entry is written. Thus, operating systems can provide special purpose maps; for example, a typical frame buffer can be memory mapped using only one TLB entry.

The second mechanism controls the replacement algorithm when a TLB miss occurs. The R4600 provides a random replacement algorithm to select a TLB entry to be written with a new mapping; however, the processor provides a mechanism whereby a system specific number of mappings can be locked into the TLB, and thus avoid being randomly replaced. This facilitates the design of real-time systems, by allowing deterministic access to critical software.

The joint TLB also contains information to control the cache coherency protocol for each page. Specifically, each page has attribute bits to determine whether the coherency algorithm is: uncached, non-coherent write-back, non-coherent write-through write-allocate, non-coherent write-through no write-allocate. Non-coherent write-back is typically used for both code and data on the R4600; the write-through modes support more efficient frame buffer accesses than the R4000 family, cache coherency is not supported, however.

Instruction TLB

The R4600 also incorporates a 2-entry instruction TLB. Each entry maps a 4KB page. The instruction TLB improves performance by allowing instruction address translation to occur in parallel with data address translation. When a miss occurs on an instruction address translation, the least-recently used ITLB entry is filled from the JTLB. The operation of the ITLB is invisible to the user.

Figure 3. The R4600 CP0 Registers

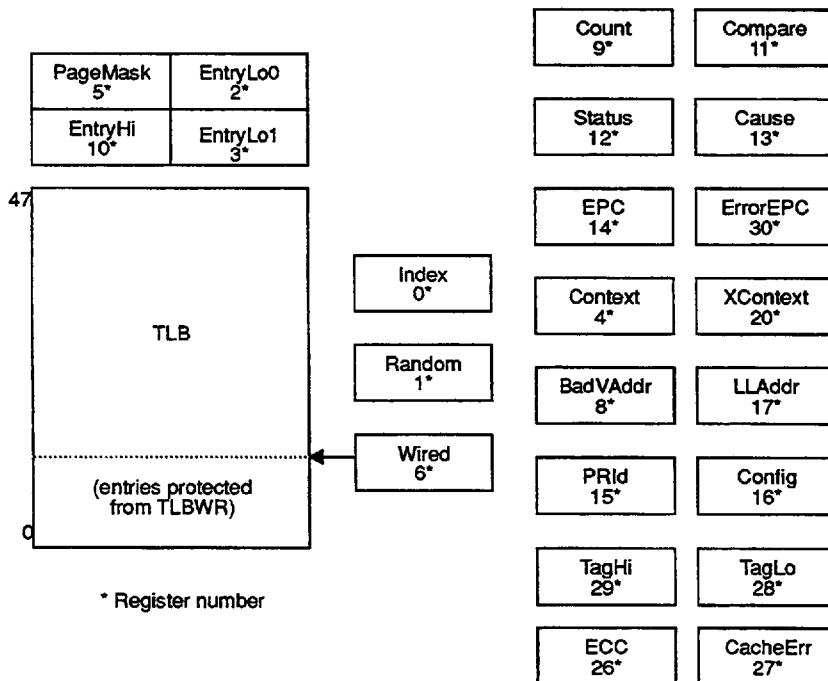

Data TLB

The R4600 also incorporates a 4-entry data TLB. Each entry maps a 4KB page. The data TLB improves performance by allowing data address translation to occur in parallel with data address translation. When a miss occurs on an data address translation, the DTLB is filled from the JTLB. The DTLB refill is pseudo-LRU: the least recently used entry of the least recently used half is filled. The operation of the DTLB is invisible to the user.

Furthermore, the large 2-way set-associative caches increase emulation performance of DOS and Windows 3.1 applications when running under Windows NT.

Cache Memory

In order to keep the R4600's high-performance pipeline full and operating efficiently, the R4600 incorporates on-chip instruction and data caches that can be accessed in a single processor cycle. Each cache has its own 64-bit data

path and can be accessed in parallel. The cache subsystem provides the integer and floating-point units with an aggregate bandwidth of 1.6GB per second at a pipeline-clock frequency of 100MHz.

Instruction Cache

The R4600 incorporates a two-way set associative on-chip instruction cache. This virtually indexed, physically tagged cache is 16KB in size and is protected with word parity.

Because the cache is virtually indexed, the virtual-to-physical address translation occurs in parallel with the cache access, thus further increasing performance by allowing these two operations to occur simultaneously. The tag holds a 24-bit physical address and valid bit, and is parity protected.

The instruction cache is 64-bits wide, and can be refilled or accessed in a single processor cycle. Instruction fetches require only 32 bits per cycle, for a peak instruction bandwidth of 400MB/sec. Sequential accesses take advantage of the 64-bit fetch to reduce power dissipation, and cache miss refill writes 64 bits per cycle to minimize the cache miss penalty. The line size is eight instructions (32 bytes) to maximize performance.

Data Cache

For fast, single cycle data access, the R4600 includes a 16KB on-chip data cache that is two-way set associative with a fixed 32-byte (eight words) line size.

The data cache is protected with byte parity and its tag is protected with a single parity bit. It is virtually indexed and physically tagged to allow simultaneous address translation and data cache access

The normal write policy is writeback, which means that a store to a cache line does not immediately cause memory to be updated. This increases system performance by reducing bus traffic and eliminating the bottleneck of waiting for each store operation to finish before issuing a subsequent memory operation. Software can however select write-through on a per-page basis when it is appropriate, such as for frame buffers.

Associated with the Data Cache is the store buffer. When the R4600 executes a Store instruction, this single-entry buffer gets written with the store data while the tag comparison is performed. If the tag matches, then the data is written into the Data Cache in the next cycle that the Data Cache is not accessed (the next non-load cycle). The store buffer allows the R4600 to execute a store every processor cycle and to perform back-to-back stores without penalty.

Write buffer

Writes to external memory, whether cache miss writebacks or stores to uncached or write-through addresses, use the on-chip write buffer. The write buffer holds up to four 64-bit address and data pairs. The entire buffer is used for a data cache writeback and allows the processor to proceed in parallel with memory update. For uncached and write-through stores, the write buffer significantly increases

Figure 4. Kernel Mode Virtual Addressing (32-bit mode)

0xFFFFFFFF	Kernel virtual address space (kseg3) Mapped, 0.5GB
0xE0000000	
0xDFFFFFFF	Supervisor virtual address space (sseg) Mapped, 0.5GB
0xC0000000	
0xBFFFFFFF	Uncached kernel physical address space (kseg1) Unmapped, 0.5GB
0xA0000000	
0x9FFFFFFF	Cached kernel physical address space (kseg0) Unmapped, 0.5GB
0x80000000	
0x7FFFFFFF	User virtual address space (useg) Mapped, 2.0GB
0x00000000	

performance over the R4000 family of processors.

System Interface

The R4600 supports a 64-bit system interface that is compatible with the R4000PC system interface. This interface operates from two clocks provided by the R4600, *TClock* [1:0] and *RClock* [1:0], at some division of the internal clock.

The interface consists of a 64-bit Address/Data bus with 8 check bits and a 9-bit command bus protected with parity. In addition, there are 8 handshake signals and 6 interrupt inputs. The interface has a simple timing specification and is capable of transferring data between the processor and memory at a peak rate of 400MB/sec at 50MHz.

Figure 5 on page 7 shows a typical system using the R4600. In this example two banks of DRAMs are used to supply and accept data with a *DDx.xDD* data pattern.

System Address/Data Bus

The 64-bit System Address Data (*SysAD*) bus is used to transfer addresses and data between the R4600 and the rest of the system. It is protected with an 8-bit parity check bus, *SysADC*.

The system interface is configurable to allow easier interfacing to memory and I/O systems of varying frequencies. The data rate and the bus frequency at which the R4600 transmits data to the system interface are programmable via boot time mode control bits. Also, the rate at which the processor receives data is fully controlled by the external device. Therefore, either a low cost interface requiring no read or write buffering or a faster, high performance interface can be designed to communicate with the R4600. Again, the system designer has the flexibility to make these price/performance trade-offs.

System Command Bus

The R4600 interface has a 9-bit System Command (*SysCmd*) bus. The command bus indicates whether the *SysAD* bus carries an address or data. If the *SysAD* carries

an address, then the *SysCmd* bus also indicates what type of transaction is to take place (for example, a read or write). If the *SysAD* carries data, then the *SysCmd* bus also gives information about the data (for example, this is the last data word transmitted, or the cache state of this data line is clean exclusive). The *SysCmd* bus is bidirectional to support both processor requests and external requests to the R4600. Processor requests are initiated by the R4600 and responded to by an external device. External requests are issued by an external device and require the R4600 to respond.

The R4600 supports one to eight byte and block transfers on the *SysAD* bus. In the case of a sub-doubleword transfer, the low-order 3 address bits gives the byte address of the transfer, and the *SysCmd* bus indicates the number of bytes being transferred.

Handshake Signals

There are six handshake signals on the system interface. Two of these, *RdRdy* and *WrRdy* are used by an external device to indicate to the R4600 whether it can accept a new read or write transaction. The R4600 samples these signals before deasserting the address on read and write requests.

ExtRqst and *Release* are used to transfer control of the *SysAD* and *SysCmd* buses between the processor and an external device. When an external device needs to control the interface, it asserts *ExtRqst*. The R4600 responds by asserting *Release* to release the system interface to slave state.

ValidOut and *ValidIn* are used by the R4600 and the external device respectively to indicate that there is a valid command or data on the *SysAD* and *SysCmd* buses. The R4600 asserts *ValidOut* when it is driving these buses with a valid command or data, and the external device drives *ValidIn* when it has control of the buses and is driving a valid command or data.

Figure 5. Typical Desktop System Block Diagram

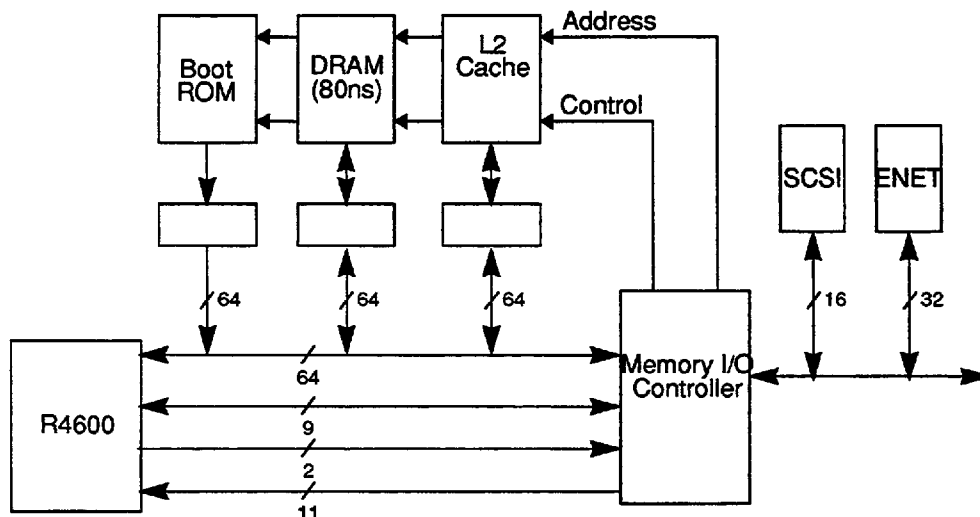

Non-overlapping System Interface

The R4600 requires a non-overlapping system interface, compatible with the R4000PC. This means that only one processor request may be outstanding at a time and that the request must be serviced by an external device before the R4600 issues another request. The R4600 can issue read and write requests to an external device, and an external device can issue read and write requests to the R4600.

The R4600 asserts ValidOut and simultaneously drives the address and read command on the SysAD and SysCmd buses. If the system interface has RdRdy asserted, then the processor tristates its drivers and releases the system interface to slave state by asserting Release. The external device can then begin sending the data to the R4600.

Figure 6 on page 8 shows a processor block read request and the external agent read response. The read latency is 4 cycles (ValidOut to ValidIn), and the response data pattern is DDxxDD. Figure 6 on page 8 shows a processor block write.

External Requests

The R4600 responds to requests issued by an external device. The requests can take several forms. An external device may need to supply data in response to an R4600 read request or it may need to gain control over the system interface bus to access other resources which may be on that bus. It also may issue requests to the processor, such as a request for the R4600 to write to the R4600 interrupt register.

The following is a list of the supported external requests:

- Write
- Null

Boot Time Options

Fundamental operational modes for the processor are initialized by the boot-time mode control interface. The boot-time mode control interface is a serial interface operating at a very low frequency (MasterClock divided by 256). The low frequency operation allows the initialization information to be kept in a low cost EPROM; alternatively the twenty or so bits could be generated by the system interface ASIC.

Immediately after the VCCOk Signal is asserted, the processor reads a serial bit stream of 256 bits to initialize all fundamental operational modes. After initialization is complete, the processor continues to drive the serial clock output, but no further initialization bits are read.

JTAG Interface

For compatibility with the R4000PC, the R4600 supports the JTAG interface pins, with the serial input connected to serial output. Boundary scan is not supported.

Boot-Time Modes

The boot-time serial mode stream is defined in Table 3 below. Bit 0 is the bit presented to the processor when VCCOk is asserted; bit 255 is the last.

Power Management

CP0 is also used to control the power management for the R4600. This is the standby mode and it can be used to reduce the power consumption of the internal core of the CPU. The standby mode is entered by executing the WAIT instruction with the SysAD bus idle and is exited by any interrupt.

Figure 6. Processor Block Read

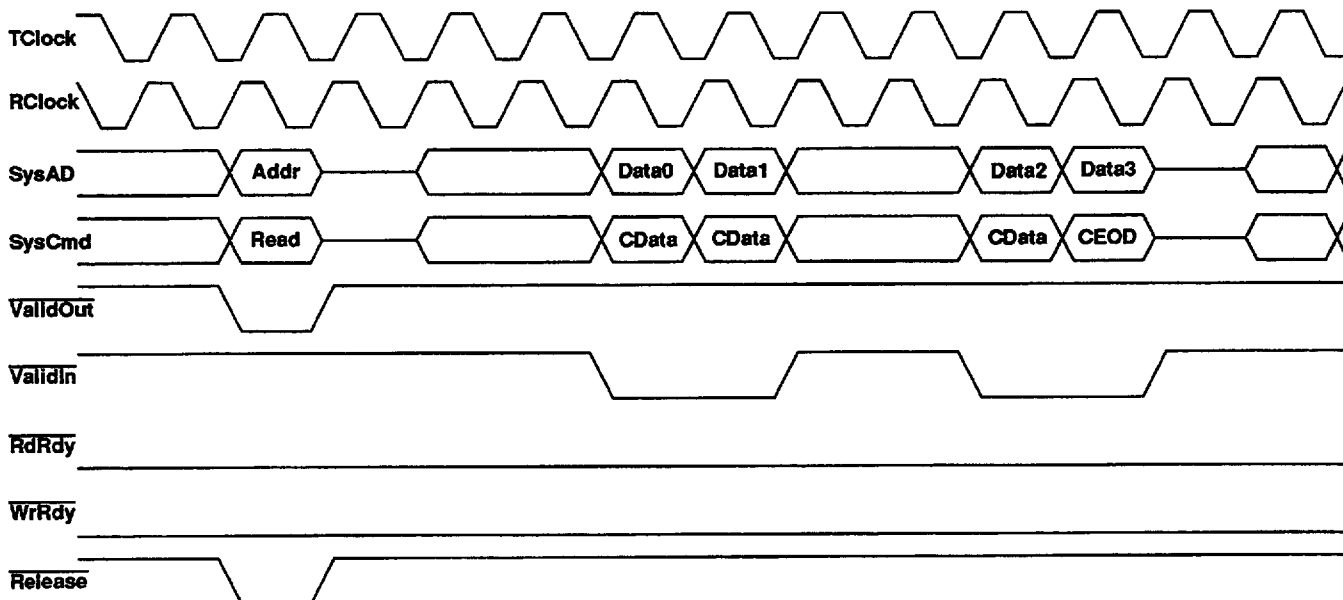

Table 3: Boot time mode stream

Table 3: Boot time mode stream

Mode bit	Description
0	reserved (must be zero)
4..1	Writeback data rate 0 → D, 1 → DDx, 2 → DDxx, 3 → DxDx, 4 → DDxxx, 5 → DDxxxx, 6 → DxxDxx, 7 → DDxxxxx, 8 → DxxxDxxx, 9-15 reserved
7..5	Clock divisor 0 → 2, 1 → 3, 2 → 4, 3 → 5, 4 → 6, 5 → 7, 6 → 8, 7 reserved
8	0 → Little endian, 1 → Big endian
10..9	00 → R4000 compatible, 01 → reserved, 10 → pipelined writes, 11 → write re-issue
11	Disable the timer interrupt on Int[5].

Mode bit	Description
12	reserved (must be zero)
14..13	Output driver strength 10 → 100% strength (fastest), 11 → 83% strength, 00 → 67% strength, 01 → 50% strength (slowest) Reserved
255..15	must be zero

Figure 7. Processor Block Write

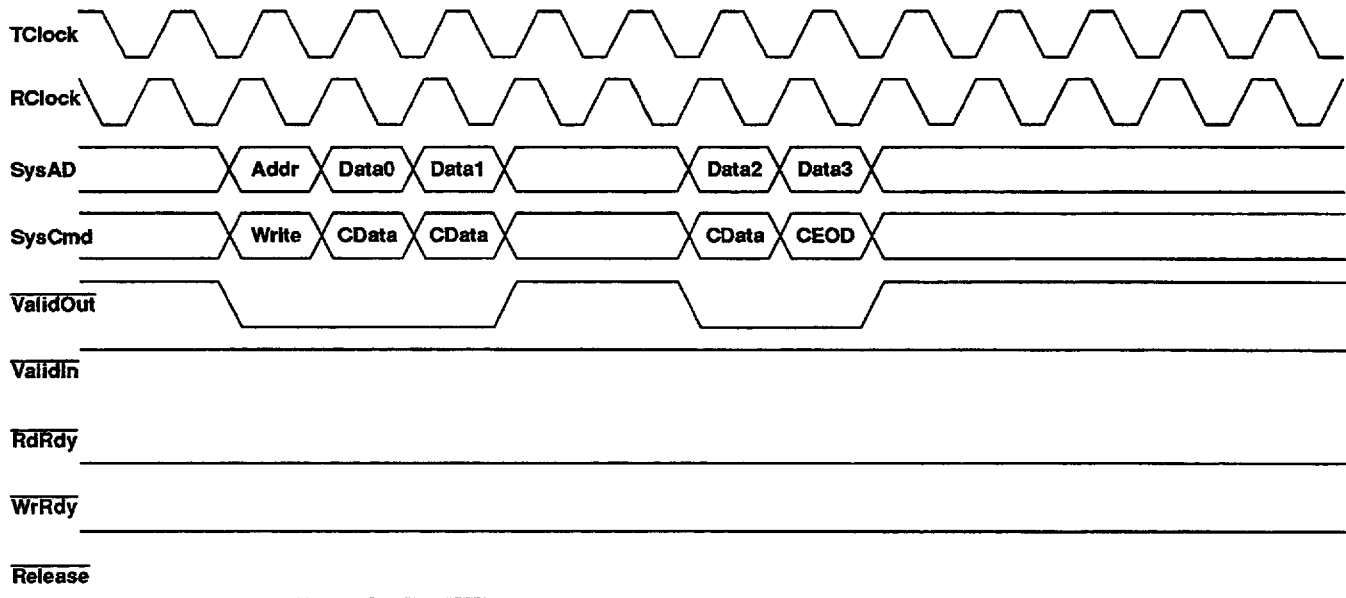

Differences from the R4000PC

Tables 4 to 10 highlight some of the differences between the R4600 and the R4000PC. This list is not exhaustive.

Table 4: System interface comparison between R4000PC and R4600

	R4000PC	R4600
I/O	TTL compatible	R4600V: LVCMOS (3.3V±0.3V) R4600: TTL-compatible (5V±0.5V)
Package	179-pin ceramic PGA	same and 208-pin MQUAD
JTAG	yes	no (serial out connected directly to serial in?)
Block transfer sizes	16B or 32B	32B
Sclock divisor	2, 3, or 4	2, 3
Non-block writes	max throughput of 4 sclock cycles	two new system interface protocol options that support 2 sclock cycle throughput (remains 4 in compatibility mode)
Serial configuration	as described in <i>R4000 User's Guide</i>	different, as described in Table 3
Address bits 63..56 on reads and writes	zero	bits 19..12 of virtual address
Uncached and write-through stores	uncached stores stall until sent on system interface	uncached and write-through stores buffered in 4-entry write buffer
SysADC	parity only	same
SysADC for non-data cycles	zero on R4000, parity on R4400	zero
Parity error during writeback	use Cache Error exception	output bad parity
Error bit in data identifier of read responses	Bus Error if error bit set for any doubleword	Only check error bit of first doubleword; all other error bits ignored
Parity error on read data	Bus Error if parity error in any doubleword	bad parity written to cache; take Cache Error exception if bad parity occurs on doublewords that the processor is waiting for
Block writes	1-2 null cycles between address and data	0 cycles between address and data
Release after Read Request	variable latency	0 latency
SysAD value for x cycles of writeback data pattern	data bus undefined	data bus maintains last D cycle value
SysAD bus use after last D cycle of writeback	?	unused for trailing x cycles (e.g. DDxxDDxx, not DDxxDD)
Output slew rate	dynamic feedback control	simple CMOS output buffers with 2-bit static strength control
IOOut output	output slew rate control feedback loop output	driven high, do not connect (reserved for future output)
IOIn input	output slew rate control input	should be driven high (reserved for future input)
GrpRunB output	do not connect	same (reserved for future output)
GrpStallB input	should be connected to VCC	same (reserved for future input)
FaultB output pin	indicates compare mismatch	driven high, do not connect (reserved for future output)

Table 5: Cache comparison between R4000PC and R4600

	R4000PC	R4600
Cache Sizes	8KB Instruction cache, 8KB Data cache	16KB Instruction cache, 16KB Data cache
Cache Line Sizes	software selectable between 16B and 32B	fixed at 32B
Cache Index	vAddr _{12..0}	same
Cache Tag	pAddr _{35..12}	same
Cache Organization	direct mapped	2-way set associative
Data cache write policy	write-allocate and write-back	write-allocate or not based on TLB entry, write-through or not based on TLB entry
Data cache miss	stall, output address, copy dirty data to write-back buffer, refill cache, output writeback data	same, with FIFO to select the set to refill
Data order for block reads	sub-block ordering	same
Data order for block writes	sequential	same
Instruction cache miss restart	restart after all data received and written to cache	same
Data cache miss restart	restart after all data received and written to cache	restart on first doubleword, send subsequent doublewords to response buffer
Instruction Tag	2-bit cache state	1-bit cache state
Cache miss overhead	5-8? cycles	3 cycles
Instruction cache parity	1 parity bit per 8 data bits	1 parity bit per 32 data bits
Data cache parity	1 parity bit per 8 data bits	same

Table 6: TLB comparison between R4000PC and R4600

	R4000PC	R4600
Instruction virtual address translation	2-entry ITLB	same
ITLB miss	1 cycle penalty, refilled from JTLB, LRU replacement	1 cycle on branch, jump, and ERET, 2 cycles otherwise, refilled from JTLB, LRU replacement
Data virtual address translation	done directly in JTLB	4-entry DTLB
DTLB miss	n.a.	1 cycle penalty, refilled from JTLB, pseudo-LRU replacement
JTLB	48 entries of even/odd page pairs, fully associative	same
Page size	4KB, 16KB, ..., 16MB	same
Multiple entry match in JTLB	sets TS in Status and disables TLB until Reset to prevent damage	no damage for multiple match; no detection or shutdown implemented
Virtual address size	VSIZE = 40	same
Physical address size	PSIZE = 36	same

Table 7: Pipeline comparison between R4000PC and R4600

	R4000PC	R4600
ALU latency	1 cycle	1 cycle
Load latency	3 cycles	2 cycles
Branch latency	4 cycles (2 cycle penalty for taken branches)	2 cycles (no penalty for taken branches)
Store buffer (not write buffer)	2 doublewords	1 doubleword
Integer multiply	integer multiply hardware, 1 cycle to issue	done in floating-point multiplier, 4 cycles to issue
Integer divide	done in integer datapath adder, slips until done	done in floating-point adder, 4 cycles to issue
Integer multiply	HI and LO available at the same time	LO available one cycle before HI
Integer divide	HI and LO available at the same time	HI available one cycle before LO
HI and LO hazards	yes, HI and LO written early in pipeline	no, HI and LO written after W
MFHI/MFLO latency	1 cycle	2 cycles
SLLV, SRLV, SRAV	2 cycles to issue	1 cycle to issue
DSLL, DSRL, DSRA, DSLL32, DSRL32, DSRA32, DSSLV, DSRLV, DSRAV	2 cycles to issue	1 cycle to issue

Table 8: Coprocessor 0 comparison between R4000PC and R4600

	R4000PC	R4600
WatchLo, WatchHi	implemented	unimplemented
Config	as described in <i>MIPS R-Series Architecture</i>	subset
Status	as described in <i>MIPS R-Series Architecture</i> , but RP not functional	no TS or RP
Low-power standby mode	no	WAIT instruction disables internal clock, freezing pipeline and other state; resume on interrupt
MFC0/MTC0 hazard	only hazardous for certain cp0 register combinations	always hazardous -- detected and 1-cycle slip inserted
EntryLo0, EntryLo1	as described in <i>MIPS R-Series Architecture</i>	two new cache algorithms added to C field for non-coherent write-through
TagLo, TagHi, ECC, CacheErr	R4000SC bits implemented but meaningless	Only bits meaningful on R4000PC implemented
TagLo	as described in <i>MIPS R-Series Architecture</i>	bits 5..3 used for reserved bits ITag _{28..25} , bit 2 used for F bit
Exceptions	as described in <i>MIPS R-Series Architecture</i> (VCEI and VCED not possible in R4000PC)	VCEI, VCED, and WATCH exceptions not implemented
Index CACHE ops I Fill CACHE op	use vAddr _{12..4} to select line	use vAddr ₁₃ to select set, vAddr _{12..5} to select line of set
Index Store Tag CACHE op	Status.CE ignored	TagLo.P stored if Status.CE set
PRId	Imp = 0x04	Imp = 0x20

Table 9: Coprocessor 1 comparison between R4000PC and R4600

	R4000PC	R4600
Possible exception stall	only for operands that can cause exceptions	some simplifications in detection hardware
Floating-point divide	separate divide unit	done in floating-point adder
Floating-point square root	done in floating-point adder	same
Converts to/from 64-bit integer	uses unimplemented for integer operands/ results with more than 53 bits of precision	handles full 64-bit operands and results
Floating-point registers	Status.FR enables all 32 floating point registers	same
FCR0	Imp = 0x05	Imp = 0x20

Table 10: R4000PC Errata comparison with R4600

	R4000PC errata	R4600
COPz rs field illegal	FPE unimplemented exception for COP1 (incorrect)	reserved instruction exception, as described in <i>MIPS R-Series Architecture</i>
BCz rt field illegal	FPE unimplemented exception for COP1 (incorrect)	reserved instruction exception, as described in <i>MIPS R-Series Architecture</i>
Address error check for xkseg	C00000FFFFFFFFF (incorrect)	C00000FF7FFFFFFF (correct)
PTEBase field of Context and XContext	same bits (incorrect)	same

PIN DESCRIPTION

The following is a list of interface, interrupt, and miscellaneous pins available on the R4600.

Pin Name	Type	Description
System interface:		
ExtRqst*	Input	External request Signals that the system interface needs to submit an external request.
Release*	Output	Release interface Signals that the processor is releasing the system interface to slave state
RdRdy*	Input	Read Ready Signals that an external agent can now accept a processor read.
WrRdy*	Input	Write Ready Signals that an external agent can now accept a processor write request.
ValidIn*	Input	Valid Input Signals that an external agent is now driving a valid address or data on the SysAD bus and a valid command or data identifier on the SysCmd bus.
ValidOut*	Output	Valid output Signals that the processor is now driving a valid address or data on the SysAD bus and a valid command or data identifier on the SysCmd bus.
SysAD(63:0)	Input/Output	System address/data bus A 64-bit address and data bus for communication between the processor and an external agent.
SysADC(7:0)	Input/Output	System address/data check bus An 8-bit bus containing parity check bits for the SysAD bus.
SysCmd(8:0)	Input/Output	System command/data identifier bus A 9-bit bus for command and data identifier transmission between the processor and an external agent.
SysCmdP	Input/Output	System command/data identifier bus parity A single, even-parity bit for the SysCmd bus.
Clock/control interface:		
MasterClock	Input	Master clock Master clock input at one half the processor operating frequency.
MasterOut	Output	Master clock out Master clock output aligned with MasterClock.
RClock(1:0)	Output	Receive clocks Two identical receive clocks at the system interface frequency.
TClock(1:0)	Output	Transmit clocks Two identical transmit clocks at the system interface frequency.
IOOut	Output	Reserved for future output Always HIGH.
IOIn	Input	Reserved for future input Should be driven high.
SyncOut	Output	Synchronization clock out Synchronization clock output. Must be connected to SyncIn through an interconnect that models the interconnect between MasterOut, TClock, RClock, and the external agent.
SyncIn	Input	Synchronization clock in Synchronization clock input. See SyncOut.

Pin Name	Type	Description
Fault*	Output	Fault Always HIGH.
VccP	Input	Quiet Vcc for PLL Quiet Vcc for the internal phase locked loop.
VssP	Input	Quiet VSS for PLL Quiet Vss for the internal phase locked loop.
Interrupt interface:		
Int*(5:0)	Input	Interrupt Six general processor interrupts, bit-wise ORed with bits 5:0 of the interrupt register.
NMI*	Input	Non-maskable interrupt Non-maskable interrupt, ORed with bit 6 of the interrupt register.
JTAG interface:		
JTDI	Input	JTAG data in JTAG serial data in.
JTCK	Input	JTAG clock input JTAG serial clock input.
JTDO	Output	JTAG data out JTAG serial data out.
JTMS	Input	JTAG command JTAG command signal, signals that the incoming serial data is command data.
Initialization interface:		
VCCOk	Input	VCC is OK When asserted, this signal indicates to the R4600 that the 3.3V (5.0V) power supply has been above 3.0V (4.5V) for more than 100 milliseconds and will remain stable. The assertion of VCCOk initiates the reading of the boot-time mode control serial stream.
ColdReset*	Input	Cold reset This signal must be asserted for a power on reset or a cold reset. The clocks SClock, TClock, and RClock begin to cycle and are synchronized with the de-assertion edge of ColdReset. ColdReset must be de-asserted synchronously with MasterOut.
Reset*	Input	Reset This signal must be asserted for any reset sequence. It may be asserted synchronously or asynchronously for a cold reset, or synchronously to initiate a warm reset. Reset must be de-asserted synchronously with MasterOut.
ModeClock	Output	Boot mode clock Serial boot-mode data clock output at the system clock frequency divided by two hundred and fifty six.
ModeIn	Input	Boot mode data in Serial boot-mode data input.

ABSOLUTE MAXIMUM RATINGS⁽¹⁾

Symbol	Rating	R4600V	R4600	Unit
		Commercial	Commercial	
V _{TERM}	Terminal Voltage with respect to GND	-0.5 ⁽²⁾ to +4.6	-0.5 ⁽²⁾ to +7.0	V
T _C	Operating Temperature (case)	0 to +85	0 to +85	°C
T _{BIAS}	Case Temperature Under Bias	-55 to +125	-55 to +125	°C
T _{STG}	Storage Temperature	-55 to +125	-55 to +125	°C
I _{IN}	DC Input Current	20 ⁽³⁾	20 ⁽³⁾	mA
I _{OUT}	DC Output Current	50	50	mA

NOTES:

- Stresses greater than those listed under ABSOLUTE MAXIMUM RATINGS may cause permanent damage to the device. This is a stress rating only and functional operation of the device at these or any other conditions above those indicated in the operational sections of this specification is not implied. Exposure to absolute maximum rating conditions for extended periods may affect reliability.
- V_{IN} minimum = -2.0V for pulse width less than 15ns. V_{IN} should not exceed V_{CC} + 0.5 Volts.
- When V_{IN} < 0V or V_{IN} > V_{CC}
- Not more than one output should be shorted at a time. Duration of the short should not exceed 30 seconds.

RECOMMENDED OPERATION
TEMPERATURE AND SUPPLY VOLTAGE

Grade	Temperature	GND	V _{CC}	
			R4600V	R4600
Commercial	0°C to +85°C (Case)	0V	3.3±0.3V	5V±0.5V

DC ELECTRICAL CHARACTERISTICS — COMMERCIAL TEMPERATURE RANGE

(V_{CC} = 3.3V ± 0.3V or 5.0V ± 0.5V; T_{CASE} = 0°C to +85°C)

Parameter	R4600V 100MHz		R4600 100MHz		Conditions
	Minimum	Maximum	Minimum	Maximum	
V _{OL}		0.1V		0.1V	I _{OUT} = 20µA
V _{OH}	V _{CC} - 0.1V		V _{CC} - 0.1V		
V _{OL}		0.4V		0.4V	I _{OUT} = 4mA
V _{OH}	2.4V		3.5V		
V _{IL}	-0.5V	0.2V _{CC}	-0.5V	0.8V	
V _{IH}	0.7V _{CC}	V _{CC} + 0.5V	2.0V	V _{CC} + 0.5V	
I _{IN}		±1µA		±10µA	0 ≤ V _{IN} ≤ V _{CC}
C _{IN}		10pF		10pF	
C _{OUT}		10pF		10pF	

Parameter	R4600V 100MHz		R4600 100MHz		Conditions
	Minimum	Maximum	Minimum	Maximum	
I _{CC}		800mA		1200mA	C _L = 0pF
		1200mA		1800mA	C _L = 50pF

AC ELECTRICAL CHARACTERISTICS — COMMERCIAL TEMPERATURE RANGE

(V_{CC}=3.3V ± 0.3V or 5.0V ± 0.5V; T_{CASE} = 0°C to +85°C)

Clock Parameters

Parameter	Symbol	Test Conditions	100MHz		Units
			Min	Max	
MasterClock High	t _{MCHigh}	Transition ≤ 5ns	4		ns
MasterClock Low	t _{MCLow}	Transition ≤ 5ns	4		ns
MasterClock Frequency ⁽⁵⁾			25	50	MHz
MasterClock Period	t _{MCP}		20	40	ns
Clock Jitter for MasterClock	t _{JitterIn}			±250	ps
Clock Jitter for MasterOut, SyncOut, TClock, RClock	t _{JitterOut}			±500	ps
MasterClock Rise Time	t _{MCRise}			5	ns
MasterClock Fall Time	t _{MCFall}			5	ns
ModeClock Period	t _{ModeCKP}			256*t _{MCP}	ns
JTAG Clock Period	t _{JTAGCKP}			4*t _{MCP}	ns

NOTES:

5. Operation of the R4600 is only guaranteed with the Phase Lock Loop enabled.

System Interface Parameters⁽⁶⁾

Parameter	Symbol	Test Conditions	R4600V 100MHz		R4600 100MHz		Units
			Min	Max	Min	Max	
Data Output ⁽⁷⁾	t _{DO}	mode _{14..13} = 10 (fastest)	1.0	7	1.0	6	ns
		mode _{14..13} = 01 (slowest)	2.0	13	2.0	12	ns
Data Setup	t _{DS}	t _{rise} = 5ns	3.5		3.5		ns
Data Hold	t _{DH}	t _{fall} = 5ns	1.5		1.5		ns

NOTES:

6. Timings are measured from 1.5V of the clock to 1.5V of the signal.

7. Capacitive load for all output timings is 50pF.

Boot Time Interface Parameters

Parameter	Symbol	Test Conditions	R4600V 100MHz		R4600 100MHz		Units
			Min	Max	Min	Max	
Mode Data Setup	t _{DS}		3		3		MasterClock cycles
Mode Data Hold	t _{DH}		0		0		MasterClock cycles

IDT79R4600

COMMERCIAL TEMPERATURE RANGE

Capacitive Load Deration

Parameter	Symbol	R4600V 100MHz		R4600 100MHz		Units
		Min	Max	Min	Max	
Load Derate	C_{LD}		2		2	ns/25pF

R4600 MQUAD package pin-out

Pin	Function	Pin	Function	Pin	Function	Pin	Function
1	N.C.	53	N.C.	105	N.C.	157	N.C.
2	N.C.	54	N.C.	106	N.C.	158	N.C.
3	Vss	55	SysCmd2	107	N.C.	159	RClock0
4	Vcc	56	SysAD36	108	N.C.	160	RClock1
5	SysAD45	57	SysAD4	109	Vcc	161	SyncOut
6	SysAD13	58	SysCmd1	110	Vss	162	SysAD30
7	FaultB	59	Vss	111	SysAD21	163	Vcc
8	SysAD44	60	Vcc	112	SysAD53	164	Vss
9	Vss	61	SysAD35	113	RdRdyB	165	SysAD62
10	Vcc	62	SysAD3	114	Modeln	166	MasterOut
11	SysAD12	63	SysCmd0	115	SysAD22	167	SysAD31
12	SysCmdP	64	SysAD34	116	SysAD54	168	SysAD63
13	SysAD43	65	Vss	117	Vcc	169	Vcc
14	SysAD11	66	Vcc	118	Vss	170	Vss
15	Vss	67	N.C.	119	ReleaseB	171	VccOK
16	Vcc	68	N.C.	120	SysAD23	172	SysADC3
17	SysCmd8	69	SysAD2	121	SysAD55	173	SysADC7
18	SysAD42	70	IntB5	122	NMIB	174	Vcc
19	SysAD10	71	SysAD33	123	Vcc	175	Vss
20	SysCmd7	72	SysAD1	124	Vss	176	N.C.
21	Vss	73	Vss	125	SysADC2	177	N.C.
22	Vcc	74	Vcc	126	SysADC6	178	N.C.
23	SysAD41	75	IntB4	127	Vcc	179	N.C.
24	SysAD9	76	SysAD32	128	SysAD24	180	N.C.
25	SysCmd6	77	SysAD0	129	Vcc	181	VccP
26	SysAD40	78	IntB3	130	Vss	182	VssP
27	N.C.	79	Vss	131	SysAD56	183	N.C.
28	N.C.	80	Vcc	132	N.C.	184	N.C.
29	Vss	81	IntB2	133	SysAD25	185	MasterClock
30	Vcc	82	SysAD16	134	SysAD57	186	Vcc
31	SysAD8	83	SysAD48	135	Vcc	187	Vss
32	SysCmd5	84	IntB1	136	Vss	188	SyncIn
33	SysADC4	85	Vss	137	IOOut	189	Vcc
34	SysADC0	86	Vcc	138	SysAD26	190	Vss
35	Vss	87	SysAD17	139	SysAD58	191	JTCK
36	Vcc	88	SysAD49	140	IOIn	192	SysADC5
37	SysCmd4	89	IntB0	141	Vcc	193	SysADC1
38	SysAD39	90	SysAD18	142	Vss	194	JTDI
39	SysAD7	91	Vss	143	SysAD27	195	Vcc
40	SysCMD3	92	Vcc	144	SysAD59	196	Vss
41	Vss	93	SysAD50	145	ColdResetB	197	SysAD47
42	Vcc	94	ValidInB	146	SysAD28	198	SysAD15
43	SysAD38	95	SysAD19	147	Vcc	199	JTD0
44	SysAD6	96	SysAD51	148	Vss	200	SysAD46
45	ModeClock	97	Vss	149	SysAD60	201	Vcc
46	WrRdyB	98	Vcc	150	ResetB	202	Vss
47	SysAD37	99	ValidOutB	151	SysAD29	203	SysAD14
48	SysAD5	100	SysAD20	152	SysAD61	204	JTMS
49	Vss	101	SysAD52	153	Vcc	205	TClock1
50	Vcc	102	ExtRqstB	154	Vss	206	TClock0
51	N.C.	103	N.C.	155	N.C.	207	N.C.
52	N.C.	104	N.C.	156	N.C.	208	N.C.

N.C. pins should be left floating for maximum flexibility and compatibility with future designs.

PHYSICAL SPECIFICATIONS — MQUAD

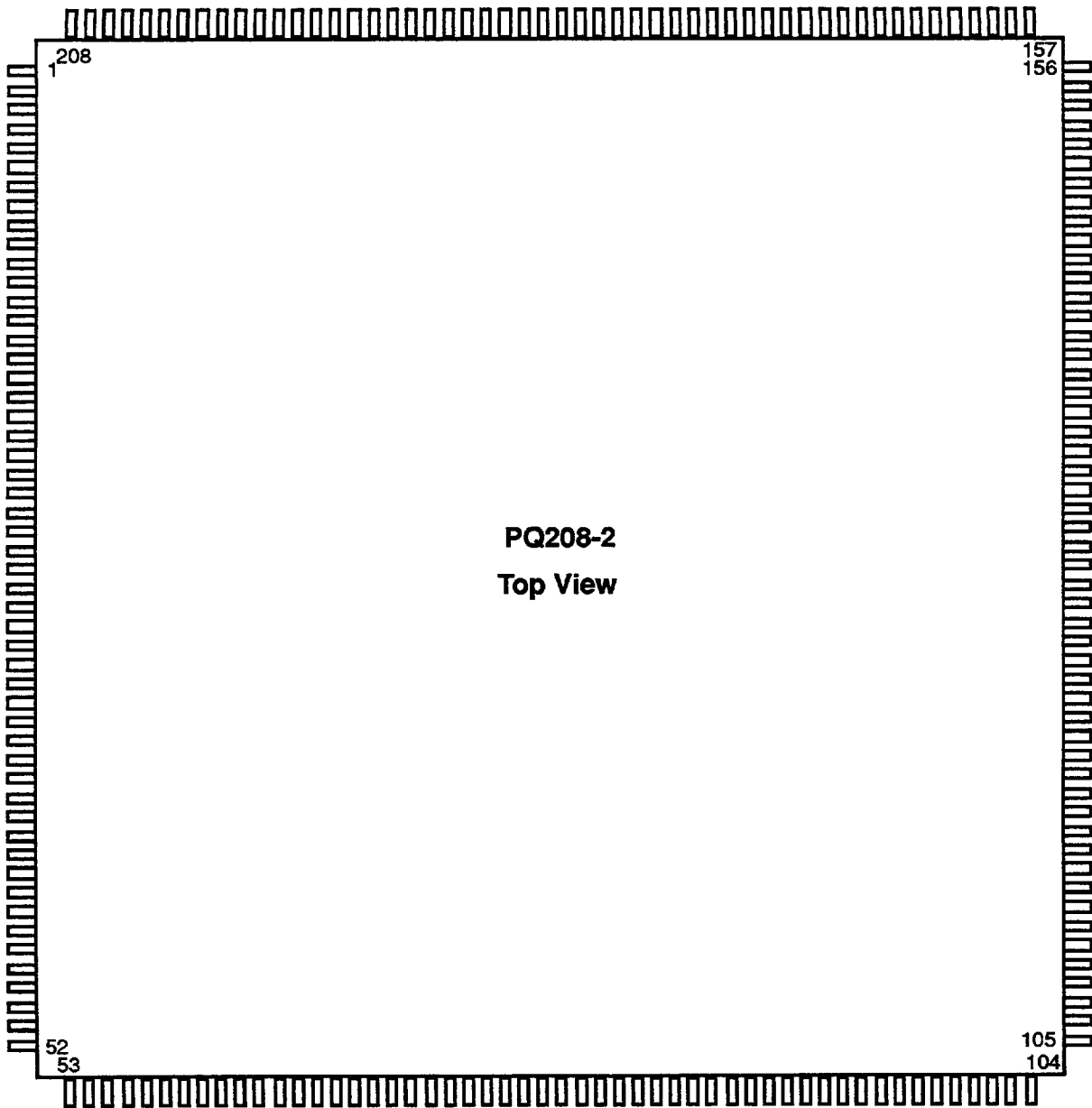

IDT79R4600

COMMERCIAL TEMPERATURE RANGE

R4600 PGA Pin-out

Function	Pin
ColdReset	T14
ExtRqst	U2
Fault	B16
Reserved O (NC)	U10
Reserved I (Vcc)	T9
IOIn	T13
IOOut	U12
Int0	N2
Int1	L3
Int2	K3
Int3	J3
Int4	H3
Int5	F2
JTCK	H17
JTDI	G16
JTDO	F16
JTMS	E16
MasterClock	J17
MasterOut	P17
ModeClock	B4
ModeIn	U4
NMI	U7
RClock0	T17
RClock1	R16
RdRdy	T5
Release	V5
Reset	U16
SyncIn	J16
SyncOut	P16
SysAD0	J2
SysAD1	G2
SysAD2	E1
SysAD3	E3
SysAD4	C2

Function	Pin
SysAD5	C4
SysAD6	B5
SysAD7	B6
SysAD8	B9
SysAD9	B11
SysAD10	C12
SysAD11	B14
SysAD12	B15
SysAD13	C16
SysAD14	D17
SysAD15	E18
SysAD16	K2
SysAD17	M2
SysAD18	P1
SysAD19	P3
SysAD20	T2
SysAD21	T4
SysAD22	U5
SysAD23	U6
SysAD24	U9
SysAD25	U11
SysAD26	T12
SysAD27	U14
SysAD28	U15
SysAD29	T16
SysAD30	R17
SysAD31	M16
SysAD32	H2
SysAD33	G3
SysAD34	F3
SysAD35	D2
SysAD36	C3
SysAD37	B3
SysAD38	C6
SysAD39	C7

Function	Pin
SysAD40	C10
SysAD41	C11
SysAD42	B13
SysAD43	A15
SysAD44	C15
SysAD45	B17
SysAD46	E17
SysAD47	F17
SysAD48	L2
SysAD49	M3
SysAD50	N3
SysAD51	R2
SysAD52	T3
SysAD53	U3
SysAD54	T6
SysAD55	T7
SysAD56	T10
SysAD57	T11
SysAD58	U13
SysAD59	V15
SysAD60	T15
SysAD61	U17
SysAD62	N16
SysAD63	N17
SysADC0	C8
SysADC1	G17
SysADC2	T8
SysADC3	L16
SysADC4	B8
SysADC5	H16
SysADC6	U8
SysADC7	L17
SysCmd0	E2
SysCmd1	D3
SysCmd2	B2

IDT79R4600

COMMERCIAL TEMPERATURE RANGE

Function	Pin
SysCmd3	A5
SysCmd4	B7
SysCmd5	C9
SysCmd6	B10
SysCmd7	B12
SysCmd8	C13
SysCmdP	C14
TClock0	C17
TClock1	D16
VCCOK	M17
ValidIn	P2
ValidOut	R3
WrRdy	C5
VccP	K17
VssP	K16
Vcc	A2
Vcc	A4
Vcc	A9
Vcc	A11
Vcc	A13
Vcc	A16
Vcc	B18
Vcc	C1
Vcc	D18
Vcc	F1
Vcc	G18
Vcc	H1
Vcc	J18
Vcc	K1
Vcc	L18
Vcc	M1
Vcc	N18
Vcc	R1
Vcc	T18
Vcc	U1

Function	Pin
Vcc	V3
Vcc	V6
Vcc	V8
Vcc	V10
Vcc	V12
Vcc	V14
Vcc	V17
Vss	A3
Vss	A6
Vss	A8
Vss	A10
Vss	A12
Vss	A14
Vss	A17
Vss	A18
Vss	B1
Vss	C18
Vss	D1
Vss	F18
Vss	G1
Vss	H18
Vss	J1
Vss	K18
Vss	L1
Vss	M18
Vss	N1
Vss	P18
Vss	R18
Vss	T1
Vss	U18
Vss	V1
Vss	V2
Vss	V4
Vss	V7
Vss	V9

Function	Pin
Vss	V11
Vss	V13
Vss	V16
Vss	V18

PHYSICAL SPECIFICATIONS — PGA

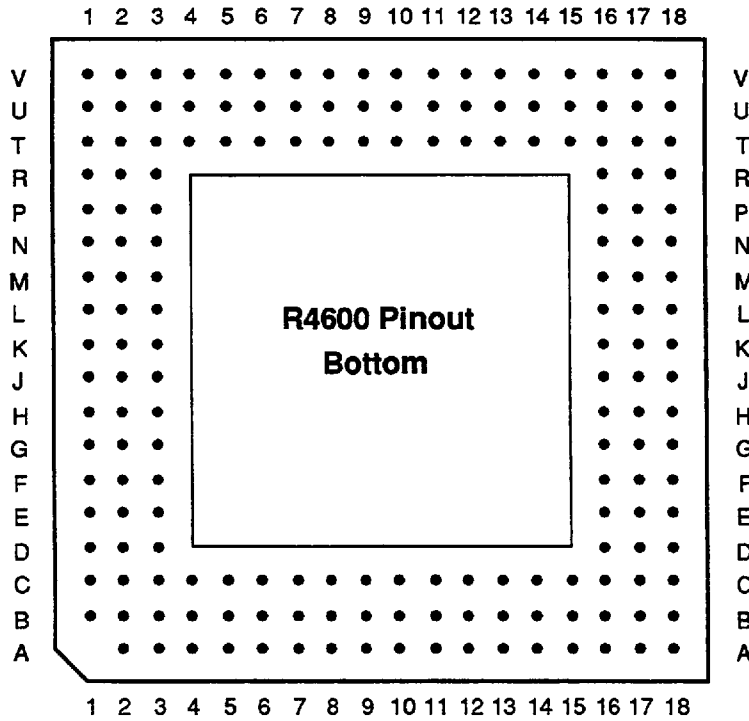

2884 drw 12

ORDERING INFORMATION

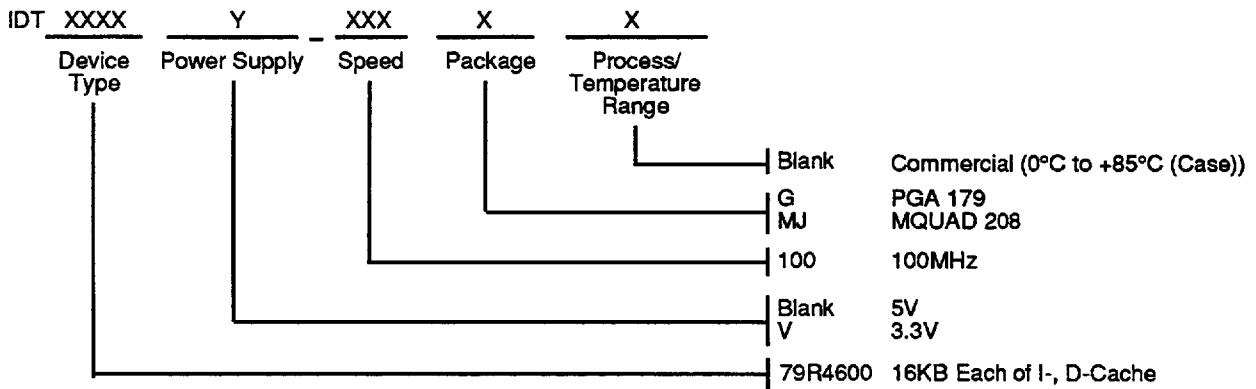

2884 drw 16