

FEATURES

- Full duplex answer and originate operation
- All filters and Hybrid circuits on chip
- Analog loopback capacity
- Output drives 600 Ω at 0 dbm (-9 dbm for SC11003)
- Lower power CMOS design with power down mode

GENERAL DESCRIPTION

The SC11002 and SC 11003 are full duplex, 0 to 300 Bit Per Second single chip modems compatible with Bell 103 specifications. They are intended for data communications over the general switched telephone network and can also be used on other voice-band channels.

The SC11002 requires +5 volts and -5 volts; the SC11003 requires a single +5 volt supply. These 3-micron, CMOS, switched capacitor filter circuits are pin compatible

with the National Semiconductor 74HC942 (SC11002) and the 74HC943 (11003) and are a functional replacement for Texas Instruments' TMS99532.

Included on chip are high-band and low-band filters, an FSK modulator and demodulator and a line driver and hybrid for directly driving a 600 Ω phone line.

Applications include integrated and stand-alone low speed

20-PIN DIP PACKAGE

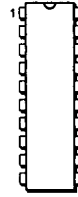

SC11002CN
SC11003CN

20-PIN SOIC PACKAGE

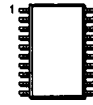

SC11002CM
SC11003CM

modems for terminals, personal computers and small business computers and as built-in modems used for remote diagnostics in electronic test systems, computer installations, industrial control systems and business machines. Since they are CMOS, they are ideal as built-in modems for portable or lap-top computers.

SC11002/SC11003 300 Bit Per Second Modems



BLOCK DIAGRAM

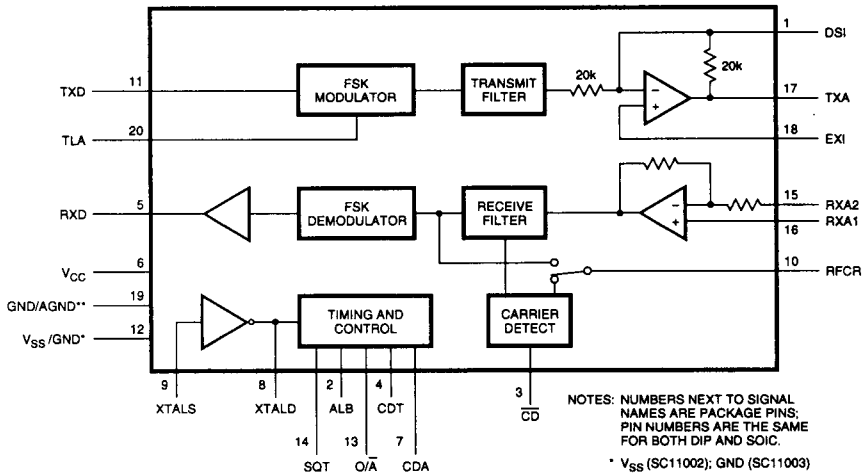

NOTES: NUMBERS NEXT TO SIGNAL NAMES ARE PACKAGE PINS; PIN NUMBERS ARE THE SAME FOR BOTH DIP AND SOIC.

* V_{SS} (SC11002); GND (SC11003)

** GND (SC11002); ANALOG GROUND (1/2 V_{CC}) ON SC11003

PIN DESCRIPTION

PIN NO.	PIN NAME	DESCRIPTION
1	DSI	Driver summing Input; used to transmit externally generated tones such as DTMF dialing signals. When not used, this pin should be left open. See functional description for details on how to use this input.
2	ALB	Analog loopback; low for normal operation, high for looping back the modulator output to the demodulator input. If ALB and SQT are simultaneously held high, the chip powers down.
3	\overline{CD}	Carrier detect output; goes low when carrier is detected.
4	CDT	Carrier detect timing input; a capacitor on this pin sets the time interval that the carrier must be present before CD goes low. For testing purposes, if this pin is connected to Pin 12, then RFCR will be connected to the output of the receive filter.
5	RXD	Received data—the data output.
6	V_{CC}	Positive supply.
7	CDA	Carrier detect adjust input; this is used for adjustment of the carrier detect threshold. Carrier detect hysteresis is set at 3 dB. For testing purposes, if this pin is connected to pin 12, the Transmit filter can be tested by using TLA as an input drive from a low output resistance signal source and TXA as the output.
8	XTALD	Crystal oscillator output; should be connected to a 3.579545 MHz crystal. It can also be driven by an external clock.
9	XTALS	Crystal oscillator input; should be connected to a 3.579545 MHz crystal. If external clock is used; this pin must be left open.
10	RFCR	Receive Filter/Carrier Rectifier; this is normally connected to the output of the carrier rectifier. If CDT is connected to Pin 12, then this pin is disconnected from the rectifier and instead it will be connected to a high impedance output of the receive filter. It may thus be used to evaluate filter performance. For normal modem operation, RFCR is AC grounded (Pin 19) via a 0.1 μ F bypass capacitor.
11	TXD	Transmit data—the data input.
12	V_{SS}/GND	Negative supply: -5 V for SC11002, ground for SC11003.
13	O/\overline{A}	Originate/Answer mode select; when high (low), this pin selects the originate (answer) mode of operation.
14	SQT	Squelch Transmitter; this disconnects the modulator output from the line driver input when held high. The EXI input, however, remains active. If SQT and ALB are held high simultaneously, the chip will power down.
15	RXA2	Receive analog (2); RXA2 and RXA1 are analog inputs. When connected as recommended, they produce a balanced hybrid.
16	RXA1	Receive analog (1); see RXA2 for details. If not used it MUST be tied to Pin 19.
17	TXA	Transmit analog output; line driver output.
18	EXI	External input; this is a high impedance input to the line driver. This input may be used to transmit externally generated tones. When not used for this purpose, it should be connected to Pin 19. See functional description for further details on how to use this input.
19	GND/ GNDA	Ground (0 V) for SC11002. Analog ground ($1/2 V_{CC}$) for SC11003.
20	TLA	Transmit level adjust; a resistor from this pin to V_{CC} sets the transmit level.

Note: Pin Numbers are identical for both DIP and SOIC packages.

FUNCTIONAL DESCRIPTION

SC11002/SC11003 can be used to transmit and receive serial digital data over general switched telephone networks, leased lines, or other equivalent narrow band channels. Up to 300 bits per second can be transmitted and received

simultaneously.

Transmitter

As shown in the block diagram, the digital input data (TXD) is first modulated by the frequency shift keying (FSK) modulator. FSK modulation is performed according to Bell 103 specifi-

cations as listed in Table 1.

Table 1. Bell 103 Transmit and Receive Tones

	High Band	Low Band
Mark	2225 Hz	1270 Hz
Space	2025 Hz	1070 Hz

To separate the transmit and receive signals, the originating modem transmits in the low band while the answering modem transmits in the high band. The transmit filter smooths and band limits the modulator output. The nominal center frequency of this filter is placed at 2125 Hz or 1170 Hz depending on whether the modem is in the answer mode or in the originate mode, respectively.

The output of the transmit filter goes through the line driver and appears at TXA (Pin 17). The signal level at TXA can be controlled by connecting a resistor between TLA (Pin 20) and V_{CC} (Pin 6). The open circuit voltage on Pin 20 is $0.1 V_{CC}$. The transmitted power levels shown in Table 2 refer to the power delivered to a 600 Ω load from the external 600 Ω source impedance. The voltage on the load is half the TXA voltage.

Table 2. Resistor Values for Adjustment of the Transmit Level at $V_{CC} = 5.0 V$.

Line Loss (dB)	Transmit Level (dBm)	Programming Resistor (RTLA)
0	-12	Open Ckt
1	-11	19800 Ω
2	-10	9200 Ω
3	-9	5490 Ω
4*	-8*	3610 Ω
5*	-7*	2520 Ω
6*	-6*	1780 Ω
7*	-5*	1240 Ω
8*	-4*	866 Ω
9*	-3*	562 Ω
10*	-2*	336 Ω
11*	-1*	150 Ω
12*	0*	0 Ω

*Applies only to SC11002.

Receiver

The analog signal received from the line is buffered by the hybrid circuit and filtered by the receive filter. The receive filter is similar to the transmit filter except that it always operates at the band opposite to the transmit filter band. When the transmit filter operates at the high band, the receive filter operates at the low band and vice versa. The output of the receive filter is hard limited and demodulated by the FSK demodulator. The demodulator output appears at RXD (Pin 5).

Carrier Detector

An adaptive level detector responds to the presence of signal energy within the receive band and generates an active low logic level on the CD output (Pin 3). This circuit has a built-in hysteresis of 2 dB, minimum. Typically, CD is activated when the received signal power exceeds -44 dBm ($V_{ON} = 4.9 mV_{rms}$) and CD is deactivated when the signal drops below -47 dBm ($V_{OFF} = 3.5 mV_{rms}$). This hysteresis prevents oscillatory operation of the carrier detector when the received signal is close to the detection threshold.

Carrier Detect Thresholds

The threshold levels can be changed by applying a voltage to CDA (Pin 7) according to the equation below:

$$V_{CDA} = 244 \times V_{ON} (V)$$

$$V_{CDA} = 345 \times V_{OFF} (V)$$

V_{CDA} is referenced to Pin 19

The open circuit voltage on Pin 7 is 0.24 V_{CC}

Converting V_{ON} and V_{OFF} to equivalent power level (across a 600 Ω resistor) in dBm

$$V_{CDA} = 189 \times 10^{P_{ON}/20} \text{ or } P_{ON} = 20 \log_{10} \left(\frac{V_{CDA}}{189} \right)$$

$$V_{CDA} = 267 \times 10^{P_{OFF}/20} \text{ or } P_{OFF} = 20 \log_{10} \left(\frac{V_{CDA}}{267} \right)$$

where P_{ON} and P_{OFF} are in dBm and V_{CDA} is in Volts.

Carrier Detect Timing

To reduce the effects of impulse noise and false triggering of the carrier detector, CD only goes low (active) when a carrier is detected and present for at least a time equal to T_{ON} . Also, to deactivate CD (i.e., going from low to high), the carrier must be removed for at least a time equal to T_{OFF} . T_{ON} and T_{OFF} can be adjusted by proper selection of the capacitor on CDT (Pin 4) according to the following equations:

$$T_{ON} \cong 6.4 \times C_{CDT}$$

$$T_{OFF} \cong 0.54 \times C_{CDT}$$

where C_{CDT} is in μF and T_{ON} and T_{OFF} are in seconds.

Line Hybrid

To attenuate the transmitted signal at TXA before it is fed back to the receiver input, TXA can be connected externally to RXA2 and also connected via a 600 Ω resistor to RXA1.

If the line impedance is also 600 Ω , then the transmit signal will appear as a common mode signal to the receiver and will effectively be eliminated. However, because the line impedance characteristics vary considerably, a perfect match with a fixed resistor rarely occurs and part of TXA is fed back to the receiver.

Transmit Squelch

When SQT is held high, the transmitter will be squelched and only the signals at EX1 or DSI, if any, may be transmitted. See DSI below.

Analog Loopback

When ALB is held high, the output of the line driver is looped back to the input of the receive filter. This feature can be used for testing the modem. If the modem is in the originate mode, then the transmit and receive filters will be tuned to the low band. On the other hand, when the modem is in the answer mode, both filters will tune to the high band.

Originate/Answer Modes

When the modem is in the originate mode ($O/\bar{A} = \text{high}$), it will transmit in the low band and receive in the high band. This situation is reversed when the modem is in the answer mode ($O/\bar{A} = \text{low}$).

Power Down Mode

To power down, SQT and ALB should be held high simultaneously.

DSI

This input can be used to transmit externally generated signals, such as DTMF tones, while the modem is in the squelched mode. The external tone should be capacitor coupled through a resistor into this pin. The gain of the transmit amplifier will then be determined by the ratio of the on-chip feedback resistor (typically 20 k Ω) and the external series resistor. Since the on chip resistor value can vary by $\pm 25\%$, it is recommended that the EX1 pin be

used as described below for accurate control of the transmitted tone level. When this pin is not used, it should be left open.

EXI

This input can be used to transmit externally generated signals, such as DTMF tones, while the modem is in squelched mode with DSI left open. The external tone should be capacitor coupled into this pin with a resistor (typically 100 k Ω) connected between this pin and the analog ground (Pin 19). Used in this manner, the transmitted tone level is twice the input tone level since the

transmit amplifier is configured internally as a gain of 2 stage. When this pin is not used, it should be connected to Pin 19.

RFCR

This output pin is normally connected to the output of the full-wave rectifier of the carrier detect circuit. To test the output of the receive filter, CDT should be connected to Pin 12 to disable the rectifier circuit. In this case, RFCR will be connected to the receive filter output and can be used for testing the receive filter.

ABSOLUTE MAXIMUM RATINGS
(Notes 1 and 2)

Supply Voltage, V_{CC}	6 V
Supply Voltage, V_{SS} SC11002 Only	-6 V
DC Input Voltage	
SC11002	$V_{SS} - 0.6$ to $V_{CC} + 0.6$ V
SC11003	-6 V to V_{CC} to +6 V
Storage Temperature Range	-65 to 150°C
Power Dissipation (Note 3)	500 mW
Lead Temperature (soldering 10 sec.)	300°C

OPERATING CONDITIONS

Parameter	Description	Conditions	Min	Typ	Max	Units
T_A	Ambient Temperature	SC11002C, SC11003C	0		70	°C
T_A	Ambient Temperature	SC11002E, SC11003E	-40		85	°C
V_{CC}	Positive Supply Voltage		4.5	5.0	5.5	V
V_{SS}	Negative Supply Voltage	SC11002 Only	-4.5	-5.0	-5.5	V
GND	Ground			0		V
GND _A	Analog Ground	SC11003 Only		$1/2 V_{CC}$		V
F_C	Crystal Frequency		3.576	3.5795	3.583	MHz
$T_{R'} T_F$	Input Rise or Fall Time				500	ns

DC ELECTRICAL CHARACTERISTICS (Note 4)

Parameter	Description	Conditions	Min	Typ	Max	Units
V_{IH}	High Level Input Voltage		3.15			V
V_{IL}	Low Level Input Voltage				1.0	V
V_{OH}	High Level Output Voltage	$V_{IN} = V_{IH}$ or V_{IL} $I_{OUT} = 20 \mu A$ $I_{OUT} = 4 mA, V_{CC} = 4.5 V$	$V_{CC} - 0.1$ 3.7	V_{CC}		V V
V_{OL}	Low Level Output Voltage	$V_{IN} = V_{IH}$ or V_{IL} $I_{OUT} = 20 \mu A$ $I_{OUT} = 4 mA, V_{CC} = 4.5 V$ $I_{OUT} = 12 mA$ (Pin 3)			0.1 0.4 0.5	V V V
I_{IN}	Input Current	$V_{IN} = V_{CC}$ or GND			± 1.0	μA
I_{CC}	Quiescent Supply Current	ALB or SQT = GND Transmit Level = -9 dBm		8		mA
I_{CC}	Power Down Supply Current	ALB = SQT = V_{CC} $V_{IH} = V_{CC}, V_{IL} = GND$		400		μA

- Notes
1. Absolute maximum ratings are those values beyond which damage to the device may occur.
 2. Unless otherwise specified, all voltages are referenced to ground.
 3. Power dissipation temperature derating: Plastic package: -12mW/C from 65°C to 85°C.
Ceramic package: -12mW/C from 100°C to 125°C
 4. Min and max values are valid over the full temperature and operating voltage range.

PERFORMANCE CHARACTERISTICS

Unless otherwise specified, all specifications apply to the test circuit shown in Figure 1. The demodulator specifica-

tions apply to operating SC11002 with a modulator having frequency accuracy, phase jitter and harmonic content equal

to or better than the SC11002 modulator. Typicals are at 25°C and ±5 v.

Parameter	Conditions	Min	Typ	Max	Units
Transmitter					
Carrier Frequency Error				4	Hz
Power Output Delivered to Line	V _{CC} = 5 V, R _L = 1200 Ω RTLA = 0 (SC11002) = 5490 (SC11003) RTLA open		0 -9 -12		dBm dBm dBm
2nd Harmonic Energy	RTLA open		-60		dBm
Receive Filter and Hybrid					
Hybrid Input Resistance (pins 15 and 16)			100		kΩ
RFCR Output Resistance	Pin 10, No External Capacitor		30		kΩ
Adjacent Channel Rejection	TXD = GND or V _{CC} Input to RXA1; RXA2 = GND (SC11002) = GNDA (SC11003)	60 60			dB dB
Demodulator (including hybrid, receive filter and discriminator)					
Maximum Carrier Amplitude			-12		dBm
Minimum Carrier Amplitude			-47		dBm
Dynamic Range			35		dB
Bit Jitter	SNR = 30 dB Input = -38 dBm Baud Rate = 300		100		μs
Bit Bias Distortion			5		%
Carrier Detect Trip Points	CDA = 1.2 V, Referenced to Pin 19 Off to On On to Off		-44 -47		dBm dBm

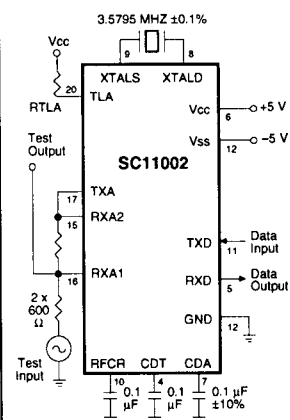

Figure 1. SC11002 AC Specification Circuit

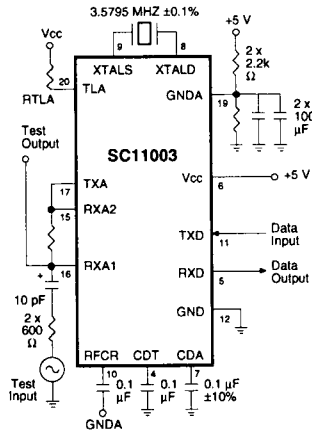

Figure 2. SC11003 AC Specification Circuit

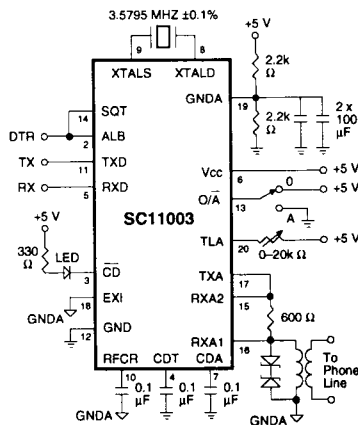

Figure 3. Simple, Direct Connect, 300 Baud Modem