

HMXADC9225 – Radiation Hardened 12-Bit, 20 MSPS Monolithic A/D Converter

The HMXADC9225 is a radiation hardened monolithic, single supply, 12-bit, 20 MSPS, analog-to-digital converter with an on-chip, high performance sample-and-hold amplifier. The HMXADC9225 uses a multistage differential pipelined architecture with output error correction logic to provide 12-bit accuracy at 20 MSPS data rates, and guarantees no missing codes over the full operating temperature range.

The HMXADC9225 combines a radiation hardened SOI-IV Silicon On Insulator (SOI) process and very low power consumption.

The input of the HMXADC9225 allows for easy interfacing to space and military imaging, sensor, and communications systems.

With a truly differential input structure, the user can select a variety of input ranges and offsets including single-ended applications. The dynamic performance is excellent.

The sample-and-hold amplifier (SHA) is well suited for both multiplexed systems that switch full-scale voltage levels in successive channels and sampling single-channel inputs at frequencies up to and well beyond the Nyquist rate.

A single clock input is used to control all internal conversion cycles. The digital output data is presented in straight binary output format.

FEATURES

- Monolithic 12-Bit, 20 MSPS A/D Converter
- Rad Hard: >1000 krad Total Dose
- Low Power Dissipation: 240 mW
- Single +5 V Analog Supply
- 5V or 3.3V Digital and I/O Supply
- No Missing Codes Guaranteed
- Differential Nonlinearity Error: 0.4 LSB
- Complete On-Chip S/H Amplifier
- Signal-to-Noise and Distortion Ratio: 69.6 dB
- Spurious-Free Dynamic Range: -81 dB
- Straight Binary Output Data
- 28-Lead Ceramic Flat Pack

Mixed Signal Rad Hard Process

The HMXADC9225 is fabricated on space qualified SOI CMOS process. High-speed precision analog circuits are now combined with high-density logic circuits that can reliably withstand the harshest environments.

Space Qualified Package

The HMXADC9225 is packaged in a 28 lead ceramic flat pack.

Low Power

The HMXADC9225 at 240 mW consumes a fraction of the power of presently available in existing monolithic solutions.

Output Enable (OE)

The OE input allows user to put the digital outputs into a high impedance tri-state mode.

Dual Power Supply Capability

The HMXADC9225 uses a single +5 V power supply simplifying system power supply design. It also features a separate digital driven supply line to accommodate 3 V and 5 V logic families.

On-Board Sample-and-Hold (SHA)

The versatile SHA input can be configured for either single-ended or differential inputs.

BLOCK DIAGRAM

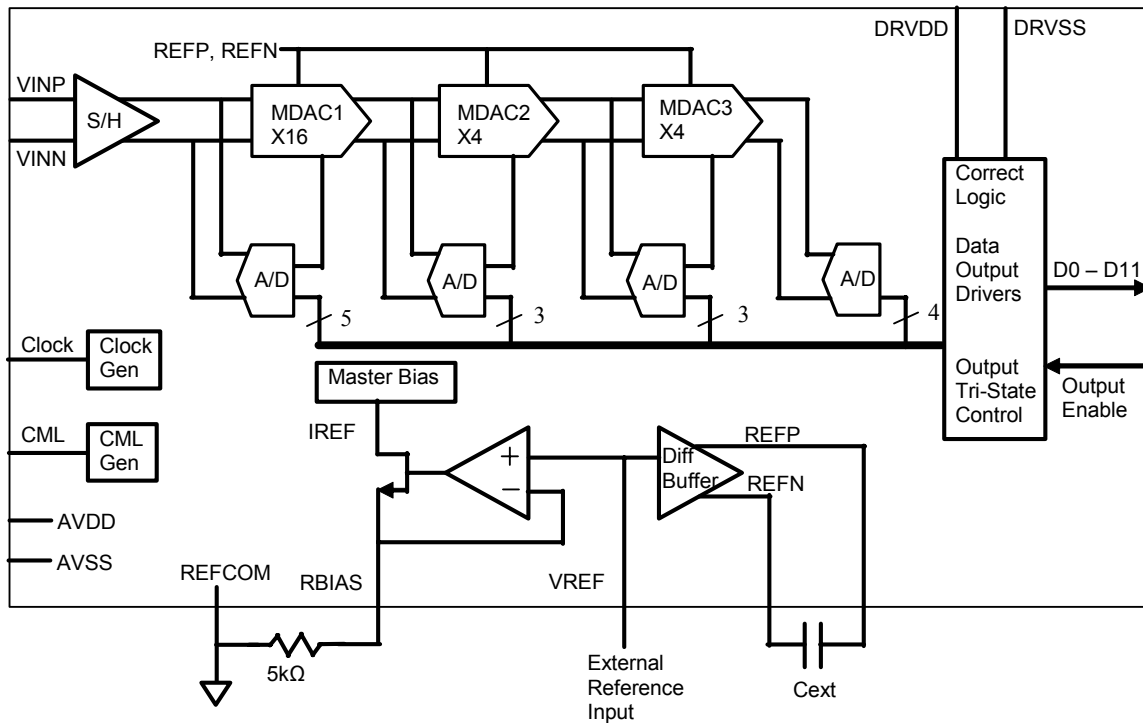

PIN DESCRIPTION

Pin	Pin Name	Description
1	CLK	Clock Input
2	BIT 12	Least Significant Data Bit (LSB)
3-12	BIT 11 – 2	Data Output Bit
13	BIT 1	Most Significant Bit (MSB)
14	OE	Output Enable (high active)
15	AVDD	+5V Analog Supply
16	AVSS	Analog Ground
17	RBIAS	Reference Current Bias Resistor
18	VREF INPUT	Reference Voltage Input
19	REFCOMM	Reference Common
20	CAPB	Noise Reduction Pin
21	CAPT	Noise Reduction Pin
22	CML	Common Mode Level
23	VINA	Analog Input (+)
24	VINB	Analog Input (-)
25	AVSS	Analog Ground
26	AVDD	+5V Analog Supply
27	DRVSS	Digital Output Driver Ground
28	DRDVDD	+5V or 3.3V Digital Output Driver Supply

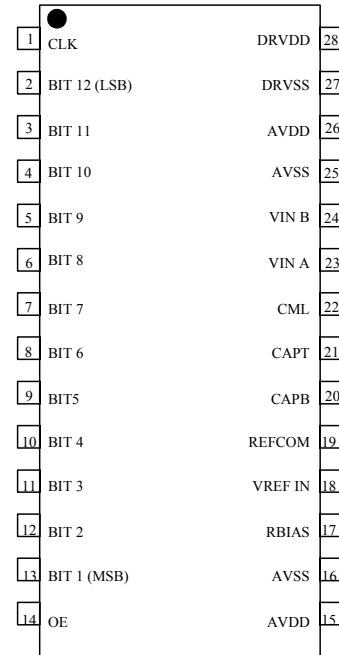

SIGNAL DEFINITION

DRVDD

The DRVDD power supply can be either 5.0V or 3.3V. The voltage used will also define the voltage level of all of the following digital I/O signals including Clock, Output Enable, all data output signals.

OUTPUT ENABLE (OE)

This signal will control the digital output signals. A high logic level will enable the outputs and a low logic level will put the outputs into a high impedance state.

TIMING DIAGRAM

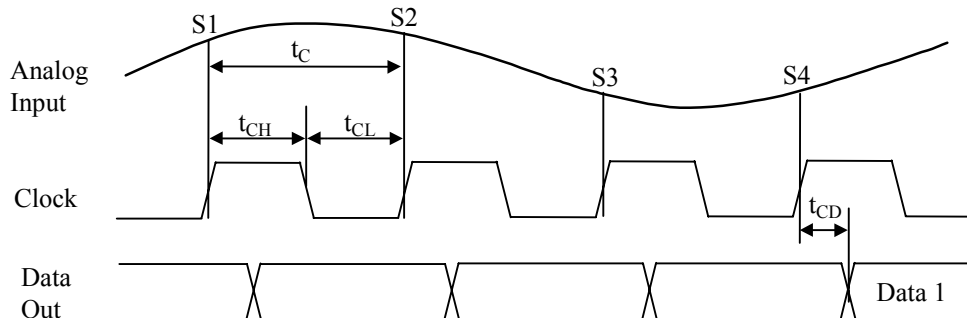

RADIATION PERFORMANCE

Total Ionizing Radiation Dose

The HMXADC9225 will meet all stated functional and electrical specifications over the entire operating temperature range after the specified total ionizing radiation dose. All electrical and timing performance parameters will remain within specifications after rebound at $V_{DD} = 5.0\text{ V}$ and $T = 125^\circ\text{C}$ extrapolated to ten years of operation. Total dose hardness is assured by wafer level testing of process monitor transistors using 10 KeV X-ray and Co60 radiation sources. Transistor gate threshold shift correlations have been made between 10 KeV X-rays applied at a dose rate of $1 \times 10^5\text{ rad}(\text{SiO}_2)/\text{min}$ at $T = 25^\circ\text{C}$ and gamma rays (Cobalt 60 source) to ensure that wafer level X-ray testing is consistent with standard military radiation test environments.

Transient Pulse Ionizing Radiation

The HMXADC9225 is capable of writing, reading, and retaining stored data during and after exposure to a transient ionizing radiation pulse, up to the specified transient dose rate upset specification, when applied under recommended operating conditions. To ensure validity of all specified performance parameters before, during, and after radiation (timing degradation during transient pulse radiation is $\pm 10\%$), it is suggested that stiffening capacitance be placed near the package V_{DD} and V_{SS} . If there are no operate through or valid stored data requirements, typical circuit board mounted de-coupling capacitors are recommended.

The HMXADC9225 will meet any functional or electrical specification after exposure to a radiation pulse up to the transient dose rate survivability specification, when applied under recommended operating conditions. Note that the current conducted during the pulse by the ADC inputs, outputs, and power supply may significantly exceed the normal operating levels. The application design must accommodate these effects.

Neutron Radiation

The HMXADC9225 will meet any functional or timing specification after exposure to the specified neutron fluence under recommended operating or storage conditions. This assumes equivalent neutron energy of 1 MeV.

Soft Error Rate

The HMXADC9225 is capable of meeting the specified Soft Error Rate (SER), under recommended operating conditions. This hardness level is defined by the Adams 90% worst case cosmic ray environment for geosynchronous orbits.

Latchup

The HMXADC9225 will not latch up due to any of the above radiation exposure conditions when applied under recommended operating conditions. Fabrication with the SIMOX substrate material provides oxide isolation between adjacent PMOS and NMOS transistors and eliminates any potential SCR latchup structures. Sufficient transistor body tie connections to the p- and n-channel substrates are made to ensure no source/drain snapback occurs.

RADIATION SPECIFICATIONS (T_{MIN} to T_{MAX} with AVDD = +5V, DRVDD = +5V, C_L = 20 pF)

Parameters	Min	Max	Units
Total Dose Hardness	$>1 \times 10^6$		Rad (SiO ₂)
Dose Rate Upset Hardness	TBD		Rad(Si)/sec
Dose Rate Survivability	TBD		Rad(Si)/sec
Soft Error Rate		TBD	Errors/bit/day
Nuetron Fluence Hardness	TBD		/cm ²

Absolute Maximum Ratings (AVDD = +5V, DRVDD = +5V, unless otherwise noted)

Parameters	Min	Max	Units
AVDD		5.5	V
DRVDD		5.5	V
AVSS	-0.3		V
REFCOMM	-0.3		V
CLK		5.5	V
Digital Outputs		5.5	V
VINA, VINB		5.5	V
VREF		5.5	V
CAPB, CAPT		5.5	V
Junction Temperature		+175	°C
Operating Temperature	-55	+125	°C

Recommended Operating Conditions

Parameter	Min	Typical	Max	Units
AVDD (Supply Voltage)	4.5	5.0	5.5	V
DRVDD (Supply Voltage, 5.0V)	4.5	5.0	5.5	V
DRVDD (Supply Voltage, 3.3V)	3.0	3.3	3.6	V
TA (Ambient Temperature)	-55	25	125	°C
Vpin (Voltage on any pin referenced to VSS)	-0.3		VDD+0.3	V

ESD (Electrostatic Discharge) Sensitive

The HMXADC9225 is sensitive to ESD above levels of 2000 volts. Proper ESD precautions should be taken to avoid degradation or damage to the device.

DC SPECIFICATIONS (AVDD = +5V, DRVDD = +5V, f_{SAMPLE} = 20 MSPS, VREF 2.0V, VINB = 2.5V dc, T_{MIN} to T_{MAX} unless otherwise noted)

Parameter	Min	Typical	Max	Units
RESOLUTION	12			Bits
MAX CONVERSION RATE	20			MHz
INPUT REFERRED NOISE				
VREF = 2.0V		0.17		LSB rms
ACCURACY				
Integral Nonlinearity (INL)		±1.2		LSB
Differential Nonlinearity (DNL)		±0.4		LSB
No Missing Codes		12		Bits Guaranteed
Zero Error (@ +25°C)		±0.3		% FSR
Gain Error (@ +25°C) ¹		±0.5		% FSR
Gain Error (@ +25°C) ²		±0.4		% FSR
Temperature Drift				
Zero Error (@ +25°C)		TBD		ppm/°C
Gain Error (@ +25°C) ¹		TBD		ppm/°C
Gain Error (@ +25°C) ²		TBD		ppm/°C
ANALOG INPUT				
Input Span		4		V p-p
Input Capacitance		TBD		pF
EXTERNAL VOLTAGE REFERENCE				
Input Voltage		2.0		V
Input Voltage Tolerance		±10	±35	mV
Current		250	500	µA
R-Bias Resistor		5k		Ohms (+/- 5%)
Cext ³		1 and 10		µF (in parallel)
POWER SUPPLIES				
Supply Voltages				
AVDD	4.75	5.0	5.25	V (±5% AVDD Operating)
DRVDD (5.0V)	4.75	5.0	5.25	V (±5% DRVDD Operating)
DRVDD (3.3V)	3.0	3.3	3.6	V
Supply Currents				
IAVDD		67		mA
IDRVDD		2.0		mA
POWER CONSUMPTION				
External Reference		335		mW

NOTES

¹ Includes internal voltage reference error.

² Excludes internal voltage reference error.

³ Cext should consist of a 1µF and 10 µF in parallel.

Specifications subject to change without notice.

AC SPECIFICATIONS (AVDD = +5V, DRVDD = +5V, f_{SAMPLE} = 20 MSPS, VREF 2.0V, T_{MIN} to T_{MAX} Differential Input unless otherwise noted)

Parameter	Min	Typical	Max	Units
SIGNAL-TO-NOISE AND DISTORTION RATIO (S/N+D) f _{INPUT} = 5 MHz		69.6		dB
SIGNAL-TO-NOISE RATION (SNR) f _{INPUT} = 5 MHz		70		dB
TOTAL HARMONIC DISTORTION (THD) f _{INPUT} = 5 MHz		-80		dB
SPURIOUS FREE DYNAMIC RANGE f _{INPUT} = 5 MHz		-81		dB
Full Power Bandwidth		TBD		MHz
Small Signal Bandwidth		TBD		MHz
Aperture Delay		TBD		ns
Aperture Jitter		TBD		ps rms
Acquisition to full-scale step		TBD		ns

Specifications subject to change without notice.

DIGITAL SPECIFICATIONS (AVDD = +5V, DRVDD = +5V, unless otherwise noted)

Parameters	Symbol	Min	Typical	Max	Units
LOGIC INPUTS					
High Level Input Voltage (5 V DRVDD)	V _{IH}	+3.5			V
Low Level Input Voltage (5 V DRVDD)	V _{IL}			+1.0	V
High Level Input Voltage (3.3 V DRVDD)	V _{IH}	+2.4			V
Low Level Input Voltage (3.3 V DRVDD)	V _{IL}			+1.0	V
High Level Input Current (V _{IN} = DRVDD)	I _{IH}	-10		+10	μA
Low Level Input Current (V _{IN} = 0 V)	I _{IL}	-10		+10	μA
Input Capacitance	C _{IN}		5		pF
LOGIC OUTPUTS					
High Level Output Voltage (I _{OH} = 50 μA)	V _{OH}	+4.5			V
High Level Output Voltage (I _{OH} = 0.5 mA)	V _{OH}	+2.4			V
Low Level Output Voltage (I _{OL} = 1.6 mA)	V _{OL}			+0.4	V
Low Level Output Voltage (I _{OL} = 50 μA)	V _{OL}			+0.1	V
Output Capacitance	C _{OUT}		5		pF

Specifications subject to change without notice.

SWITCHING SPECIFICATIONS (T_{MIN} to T_{MAX} with AVDD = +5V, DRVDD = +5V, C_L = 20 pF)

Parameters	Symbol	Min	Typical	Max	Units
Clock Period ¹	t _C	50			ns
CLOCK Pulsewidth High	t _{CH}	23			ns
CLOCK Pulsewidth Low	t _{CL}	23			ns
Output Delay	t _{OD}	13			ns

Pipeline Delay (Latency)			3		Clock Cycles
--------------------------	--	--	---	--	--------------

NOTES

¹ The clock period may be extended to 1 rms without degradation in specified performance @ +25°C.
Specifications subject to change without notice

Definitions of Specifications

INTEGRAL NONLINEARITY (INL)

INL refers to the deviation of each individual code from a line drawn from “negative full scale” through “positive full scale.” The point used as “negative full scale” occurs 1/2 LSB before the first code transition. “Positive full scale” is defined as a level 1 1/2 LSB beyond the last code transition. The deviation is measured from the middle of each particular code to the true straight line.

DIFFERENTIAL NONLINEARITY (DNL, NO MISSING CODES)

An ideal ADC exhibits code transitions that are exactly 1 LSB apart. DNL is the deviation from this ideal value. Guaranteed no missing codes to 12-bit resolution indicates that all 4096 codes, respectively, must be present over all operating ranges.

ZERO ERROR

The major carry transition should occur for an analog value 1/2 LSB below $V_{INA} = V_{INB}$. Zero error is defined as the deviation of the actual transition from that point.

GAIN ERROR

The first code transition should occur at an analog value 1/2 LSB above negative full scale. The last transition should occur at an analog value 1 1/2 LSB below the nominal full scale.

Gain error is the deviation of the actual difference between first and last code transitions and the ideal difference between first and last code transitions.

TEMPERATURE DRIFT

The temperature drift for zero error and gain error specifies the maximum change from the initial (+25°C) value to the value at T_{MIN} or T_{MAX} .

POWER SUPPLY REJECTION

The specification shows the maximum change in full scale from the value with the supply at the minimum limit to the value with the supply at its maximum limit.

APERTURE JITTER

Aperture jitter is the variation in aperture delay for successive samples and is manifested as noise on the input to the A/D.
7 www.honeywell.com.

APERTURE DELAY

Aperture delay is a measure of the sample-and-hold amplifier (SHA) performance and is measured from the rising edge of the clock input to when the input signal is held for conversion.

SIGNAL-TO-NOISE AND DISTORTION (S/N+D, SINAD) RATIO

S/N+D is the ratio of the rms value of the measured input signal to the rms sum of all other spectral components below the Nyquist frequency, including harmonics but excluding dc. The value for S/N+D is expressed in decibels.

EFFECTIVE NUMBER OF BITS (ENOB)

For a sine wave, SINAD can be expressed in terms of the number of bits. Using the following formula,

$$N = (SINAD - 1.76)/6.02$$

it is possible to get a measure of performance expressed as N , the effective number of bits.

Thus, effective number of bits for a device for sine wave inputs at a given input frequency can be calculated directly from its measured SINAD.

TOTAL HARMONIC DISTORTION (THD)

THD is the ratio of the rms sum of the first six harmonic components to the rms value of the measured input signal and is expressed as a percentage or in decibels.

SIGNAL-TO-NOISE RATIO (SNR)

SNR is the ratio of the rms value of the measured input signal to the rms sum of all other spectral components below the Nyquist frequency, excluding the first six harmonics and dc. The value for SNR is expressed in decibels.

SPURIOUS FREE DYNAMIC RANGE (SFDR)

SFDR is the difference in dB between the rms amplitude of the input signal and the peak spurious signal.

Typical Performance Characteristics

(AVDD = +5V, DRVDD = +5V, $f_{\text{SAMPLE}} = 20 \text{ MSPS}$, VREF 2.0V, VINB = 2.5V dc, T_{MIN} to T_{MAX} unless otherwise noted)

Differential Non-Linearity

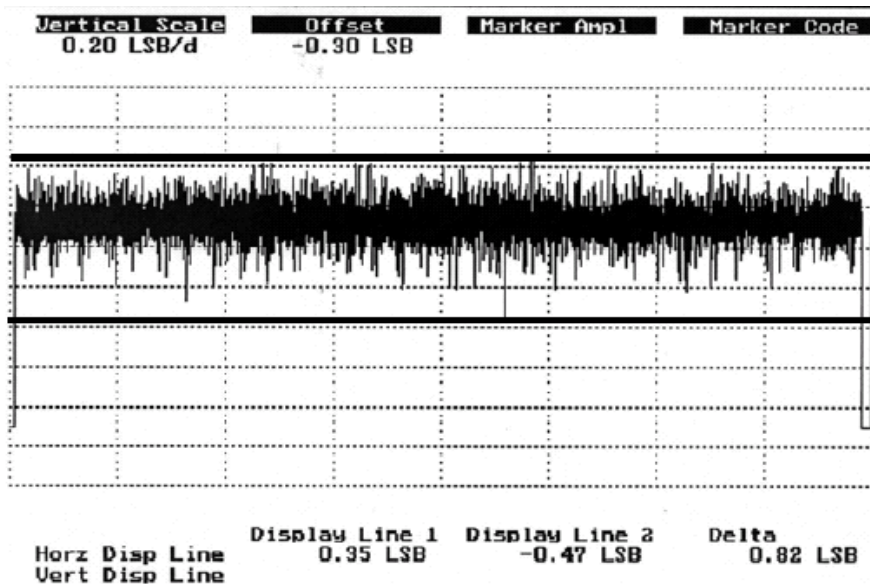

FUNCTIONAL DESCRIPTION

The HMXADC9225 is a high performance, complete single-supply 12-bit ADC. The analog input range of the HMXADC9225 is highly flexible allowing for either single-ended or differential inputs of varying amplitudes that can be AC or DC coupled.

It utilizes four-stage pipeline architecture with a wideband input sample-and-hold amplifier (SHA) implemented on an SOI CMOS process. Each stage of the pipeline, excluding the last stage, consists of a low-resolution flash A/D connected to a switched capacitor DAC and interstage residue amplifier (MDAC). The residue amplifier amplifies the difference between the reconstructed DAC output and the flash input for the next stage in the pipeline. One bit of redundancy is used in each of the stages to facilitate digital correction of flash errors. The last stage simply consists of a flash A/D.

The pipeline architecture allows a greater throughput rate at the expense of pipeline delay or latency. This means that while the converter is capable of capturing a new input sample every clock cycle, it actually takes three clock cycles for the conversion to be fully processed and appear at the output. This latency is not a concern in most applications. The digital output is latched into an output buffer to drive the output pins.

The HMXADC9225 uses both edges of the clock in its internal timing circuitry (see Timing Diagram and specification page for exact timing requirements). The A/D samples the analog input on the rising edge of the clock input. During the clock low time (between the falling edge and rising edge of the clock), the input SHA is in the sample mode; during the clock high time it is in hold. System disturbances just prior to the rising edge of the clock and/or excessive clock jitter may cause the input SHA to acquire the wrong value, and should be minimized.

ANALOG INPUT OPERATION

Figure 1 shows the equivalent analog input of the HMXADC9225, which consists of a differential sample-and-hold amplifier (SHA). The differential input structure of the SHA is highly flexible, allowing the devices to be easily configured for either a differential or single-ended input. The dc offset, or common mode voltage, of the input(s) can be set to accommodate either single-supply or dual-supply systems. Also, note that the analog inputs, VINA and VINB, are interchangeable with the exception that reversing the inputs to the VINA and VINB pins results in a polarity inversion.

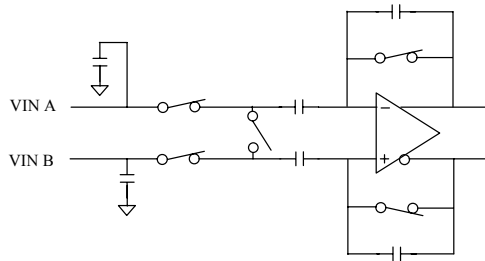

Figure 1 – Analog Input Equivalent Circuit

DIGITAL INPUTS AND OUTPUTS

Digital Outputs

The HMXADC9225 output data is presented in positive true straight binary for all input ranges. The table below indicates the output data formats for various input ranges regardless of the selected input range. A two's complement output data format can be created by inverting the MSB. The outputs can be placed in high impedance tri-state mode and is controlled by the Output Enable (OE) signal.

Output Data Format		
Input (V)	Condition (V)	Digital Output
VINA-VINB	< - VREF	0000 0000 0000
VINA-VINB	= - VREF	0000 0000 0000
VINA-VINB	= 0	1000 0000 0000
VINA-VINB	= + VREF - 1 LSB	1111 1111 1111
VINA-VINB	≥ + VREF	1111 1111 1111

Digital Output Driver Considerations (DRVDD)

The HMX9225 output drivers shall be operated at 5.0 volts or at 3.3 volts. The output drivers are sized to provide sufficient output current to drive a wide variety of logic families. However, large drive currents tend to cause glitches on the supplies and may affect SINAD performance. Applications requiring the ADC to drive large capacitive loads or large fanout may require additional decoupling capacitors on DRVDD. In extreme cases, external buffers or latches may be required.

Clock Input and Considerations

The HMX9225 internal timing uses the two edges of the clock input to generate a variety of internal timing signals. The clock input must meet or exceed the minimum specified pulse width high and low (t_{CH} and t_{CL}) specifications for the given A/D as defined in the Switching Specifications at the beginning of the data sheet to meet the rated performance specifications.

For example, the clock input to the HMX9225 operating at 20 MSPS may have a duty cycle between 45% to 55% to meet this timing requirement since the minimum specified t_{CH} and t_{CL} is 23 ns. For low clock rates, the duty cycle may deviate from this range to the extent that both t_{CH} and t_{CL} are satisfied.

All high-speed high resolution A/Ds are sensitive to the quality of the clock input. The degradation in SNR at a given full-scale input frequency (f_{IN}) due to only aperture jitter (t_A) can be calculated with the following equation:

$$SNR = 20 \log_{10} \left[\frac{1}{2\pi f_{IN} t_A} \right]$$

In the equation, the rms aperture jitter, t_A , represents the rootsum square of all the jitter sources, which include the clock input, analog input signal, and A/D aperture jitter specification. Undersampling applications are particularly sensitive to jitter.

Clock input should be treated as an analog signal in cases where aperture jitter may affect the dynamic range of the HMXADC9225. Power supplies for clock drivers should be separated from the A/D output driver supplies to avoid modulating the clock signal with digital noise. Low jitter crystal controlled oscillators make the best clock sources. If the clock is generated from another type of source (by gating, dividing, or other method), it should be retimed by the original clock at the last step. The clock input is referred to the analog supply. Its logic threshold is AVDD/2.

The HMXADC9225 has a clock tolerance of 5% at 20 MHz and should be a 50% duty cycle.

The input circuitry for the CLOCK pin is designed to accommodate CMOS inputs. The quality of the logic input, particularly the rising edge, is critical in realizing the best possible jitter performance of the part: the faster the rising edge, the better the jitter performance.

As a result, careful selection of the logic family for the clock driver, as well as the fanout and capacitive load on the clock line, is important. Jitter-induced errors become more predominant at higher frequency, large amplitude inputs, where the input slew rate is greatest.

Most of the power dissipated by the HMX9225 is from the analog power supplies. However, lower clock speeds will reduce digital current.

GROUNDING AND DECOUPLING

Analog and Digital Grounding

Proper grounding is essential in any high speed, high-resolution system. Multilayer printed circuit boards (PCBs) are recommended to provide optimal grounding and power schemes. The use of ground and power planes offers distinct advantages:

1. The minimization of the loop area encompassed by a signal and its return path.
2. The minimization of the impedance associated with ground and power paths.
3. The inherent distributed capacitor formed by the power plane, PCB insulation and ground plane.

These characteristics result in both a reduction of electromagnetic interference (EMI) and an overall improvement in performance.

It is important to design a layout that prevents noise from coupling onto the input signal. Digital signals should not be run in parallel with input signal traces and should be routed away from the input circuitry. While the HMXADC9225 features separate analog and driver ground pins, it should be treated as an analog component. The AVSS and DRVSS pins must be joined together directly under the HMXADC9225. A solid ground plane under the A/D is acceptable if the power and ground return currents are carefully managed. Alternatively, the ground plane under the A/D may contain serrations to steer currents in predictable directions where cross coupling between analog and digital would otherwise be unavoidable.

Analog and Digital Driver Supply Decoupling

The HMXADC9225 features separate analog and driver supply and ground pins, helping to minimize digital corruption of sensitive analog signals.

In general, AVDD, the analog supply, should be decoupled to AVSS, the analog common, as close to the chip as physically possible.

It is recommended to use 0.1 mF ceramic chip and 10 mF tantalum capacitors for the AVDD and DRVDD power inputs. A 0.1 mF ceramic chip capacitor is adequate on the CML pin.

QUALITY AND RADIATION HARDNESS ASSURANCE

Honeywell maintains a high level of product integrity through process control, utilizing statistical process and six sigma controls. It is part of a "Total Quality Assurance Program", the computer based process performance tracking system and a radiation hardness assurance strategy.

SCREENING LEVELS

Honeywell offers several levels of device screening to meet your needs. "Engineering Devices" are available with limited performance and screening for prototype development and evaluation testing. Hi-Rel Level B and S devices undergo additional screening per the requirements of MIL-STD-883.

RELIABILITY

Honeywell understands the stringent reliability requirements that space and defense systems requires and has extensive experience in reliability testing on programs of this nature. Reliability attributes of the SOI process were characterized by testing specially designed structures to evaluate failure mechanisms including hot carriers, electro-migration, and time-dependent dielectric breakdown. The results are fed back to improve the process to ensure the highest reliability products.

In addition, our products are subjected to dynamic, accelerated life tests. The packages used are qualified through MIL-STD-883, TM 5005 Class S. The product screening flow can be modified to meet the customer's specific requirements. Quality conformance testing is performed as an option on all production lots to ensure on-going reliability.

PACKAGE OUTLINE DIMENSIONS

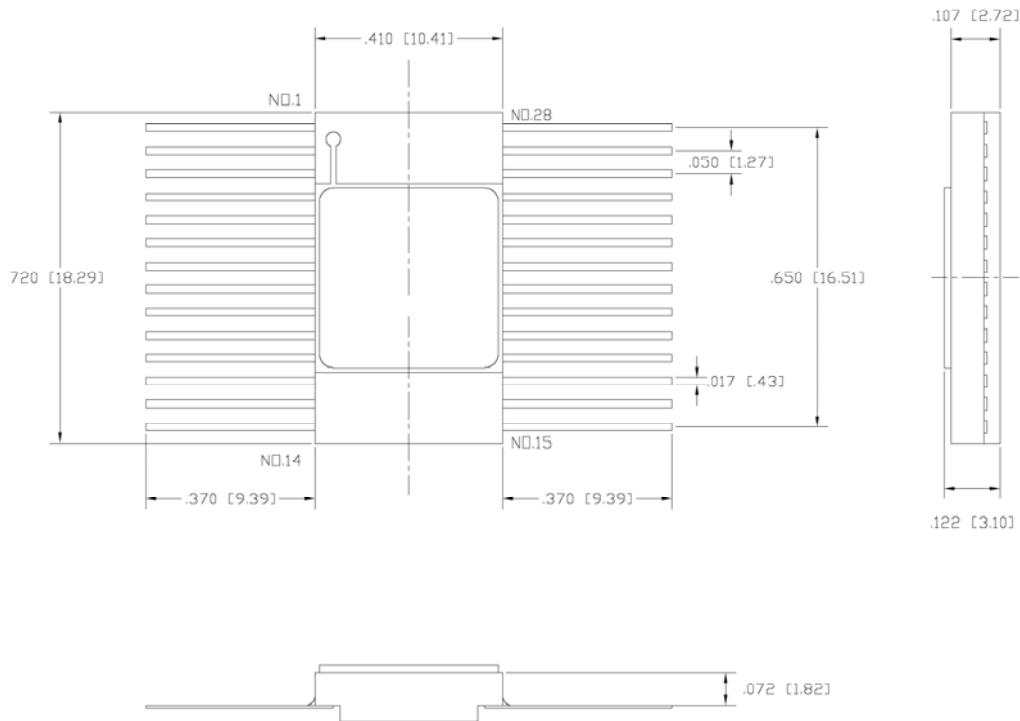

ORDERING INFORMATION

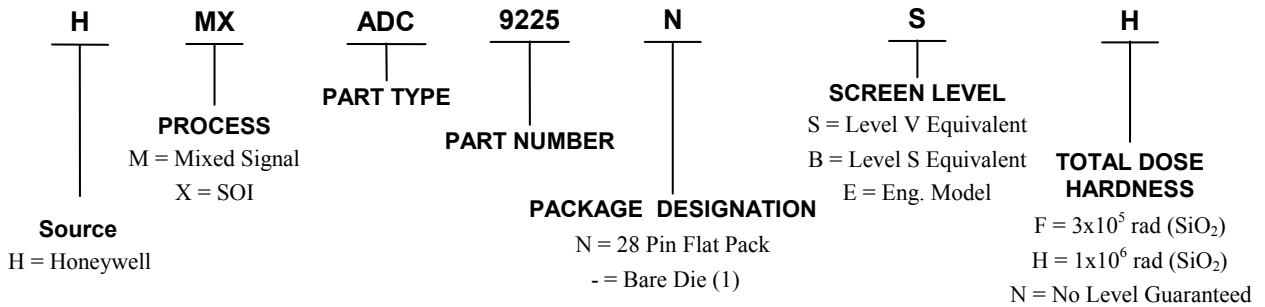

Note 1 – Bare die option is not yet available.

Honeywell reserves the right to make changes to any products or technology herein to improve reliability, function or design. Honeywell does not assume any liability arising out of the application or use of any product or circuit described herein; neither does it convey any license under its patent rights nor the rights of others.

To learn more about Honeywell’s radiation hardened integrated circuit products and technologies, visit www.myspaceparts.com.

Honeywell International Inc.
Aerospace Electronics Systems
Defense & Space Electronics Systems
12001 Highway 55
Plymouth, MN 55441
1-800-323-8295
www.honeywell.com

Form #900313
August 2005
©2005 Honeywell International Inc.