

Features

- 2KByte SRAM Cache Memory for 15ns Random Reads Within a Page
- Fast DRAM Array for 35ns Access to Any New Page
- Write Posting Register for 15ns Random Writes and Burst Writes Within a Page (Hit or Miss)
- 2KByte Wide DRAM to SRAM Bus for 58.6 Gigabytes/Sec Cache Fill
- On-chip Cache Hit/Miss Comparators Maintain Cache Coherency on Writes
- Hidden Precharge and Refresh Cycles
- Extended 64ms Refresh Period for Low Standby Power
- Standard CMOS/TTL Compatible I/O Levels and +5 Volt Supply
- Compatibility with JEDEC 1M x 36 DRAM SIMM Configuration Allows Performance Upgrade in System

Description

The Enhanced Memory Systems 4MB EDRAM SIMM module provides a single memory module solution for the main memory or local memory of fast PCs, workstations, servers, and other high performance systems. Due to its fast 15ns cache row register, the EDRAM memory module supports zero-wait-state burst read operations at up to 40MHz bus rates in a non-interleave configuration and >66MHz bus rates with a two-way interleave configuration.

On-chip write posting and fast page mode operation supports 15ns write and burst write operations. On a cache miss, the fast DRAM array reloads the entire 2KByte cache over a 2KByte-wide bus in 35ns for an effective bandwidth of 58 Gbytes/sec. This means very low latency and fewer wait states on a cache miss than a non-integrated cache/DRAM solution. The JEDEC compatible 72-bit SIMM configuration allows a single memory controller to be designed to support either JEDEC slow DRAMs or high speed EDRAMs to provide a simple upgrade path to higher system performance.

Architecture

The DM1M36SJ achieves 1Mb x 36 density by mounting nine 1Mb x 4 EDRAMs, packaged in 28-pin plastic SOJ packages, on a multi-layer substrate. Eight DM2202 devices and one DM2212 device provide data and parity storage. The DM1M32SJ contains eight DM2202 devices for data only.

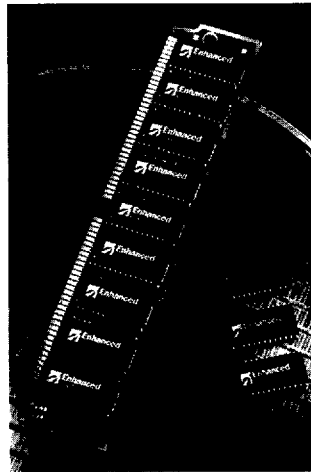

The EDRAM memory module architecture is very similar to a standard 4MB DRAM module with the addition of an integrated cache and on-chip control which allows it to operate much like a page mode or static column DRAM.

The EDRAM's SRAM cache is integrated into the DRAM array as tightly coupled row registers.

Memory reads always occur from the cache row register. When the on-chip comparator detects a page hit, only the SRAM is accessed and data is available in 15ns from column address. When a page read miss is detected, the entire new DRAM row is loaded into the cache and data is available at the output all within 35ns from row enable. Subsequent reads within the page (burst reads or random reads) will continue at 15ns cycle time. Since reads occur from the SRAM cache, the DRAM precharge can occur simultaneously without degrading performance. The on-chip refresh counter with independent refresh bus allows the EDRAM to be refreshed during cache reads.

Memory writes are internally posted in 15ns and directed to the DRAM array. During a write hit, the on-chip address comparator activates a parallel write path to the SRAM cache to maintain coherency. The EDRAM delivers 15ns cycle page mode memory writes. Memory writes do not affect the contents of the cache row register except during a cache hit.

By integrating the SRAM cache as row registers in the DRAM array and keeping the on-chip control simple, the EDRAM is able to provide superior performance without any significant increase in die size over standard slow 4Mb DRAMs. By eliminating the need for SRAMs and cache controllers, system cost, board space, and power can all be reduced.

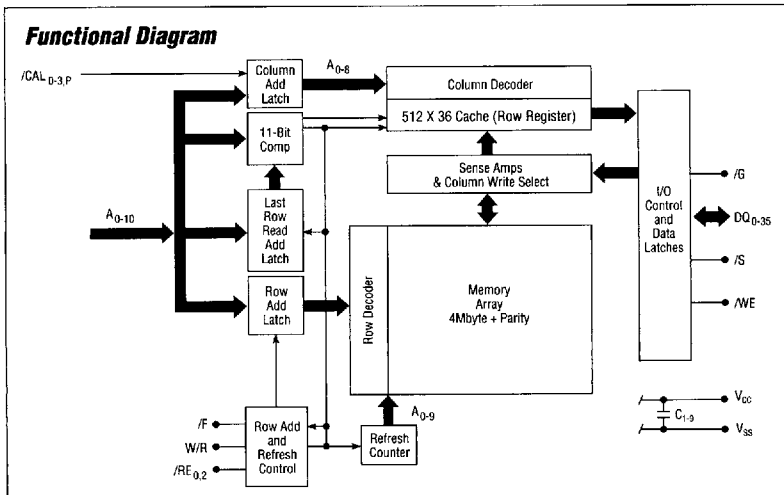

1-83

Functional Description

The EDRAM is designed to provide optimum memory performance with high speed microprocessors. As a result, it is possible to perform simultaneous operations to the DRAM and SRAM cache sections of the EDRAM. This feature allows the EDRAM to hide precharge and refresh operation during SRAM cache reads and maximize SRAM cache hit rate by maintaining valid cache contents during write operations even if data is written to another memory page. These new functions, in conjunction with the faster basic DRAM and cache speeds of the EDRAM, minimize processor wait states.

EDRAM Basic Operating Modes

The EDRAM operating modes are specified in the table below.

Hit and Miss Terminology

In this datasheet, "hit" and "miss" always refer to a hit or miss to the page of data contained in the SRAM cache row register. This is always equal to the contents of the last row that was read from (as modified by any write hit data). Writing to a new page does not cause the cache to be modified.

DRAM Read Hit

If a DRAM read request is initiated by clocking /RE with W/R low and /F and /CAL high, the EDRAM will compare the new row address to the last row read address latch (LRR; an 11-bit latch loaded on each /RE active read cycle). If the row address matches the LRR, the requested data is already in the SRAM cache and no DRAM memory reference is initiated. The data specified by the column address is available at the output pins at the greater of times t_{AC} or t_{CQV} . Since no DRAM activity is initiated, /RE can be brought high after time t_{RE1} , and a shorter precharge time, t_{RP1} , is required. It is possible to access additional SRAM cache locations by providing new column addresses to the multiplex address inputs. New data is available at the output at time t_{AC} after each column address change in static column mode. During read cycles, it is possible to operate in either static column mode with /CAL=high or page mode with /CAL clocked to latch the column address. In page mode, data valid time is determined by either t_{AC} or t_{CQV} .

EDRAM Basic Operating Modes

Function	/S	/RE	W/R	/F	A ₀₋₁₀	Comment
Read Hit	L	↓	L	H	Row = LRR	No DRAM Reference, Data in Cache
Read Miss	L	↓	L	H	Row ≠ LRR	DRAM Row to Cache
Write Hit	L	↓	H	H	Row = LRR	Write to DRAM and Cache, Reads Enabled
Write Miss	L	↓	H	H	Row ≠ LRR	Write to DRAM, Cache Not Updated, Reads Disabled
Internal Refresh	X	↓	X	L	X	
Low Power Standby	H	H	X	X	X	
Unallowed Mode	H	↓	X	H	X	

H = High; L = Low; X = Don't Care; ↓ = High-to-Low Transition; LRR = Last Row Read

DRAM Read Miss

If a DRAM read request is initiated by clocking /RE with W/R low and /F and /CAL high, the EDRAM will compare the new row address to the LRR address latch (an 11-bit latch loaded on each /RE active read cycle). If the row address does not match the LRR, the requested data is not in SRAM cache and a new row must be fetched from the DRAM. The EDRAM will load the new row data into the SRAM cache and update the LRR latch. The data at the specified column address is available at the output pins at the greater of times t_{RAC} , t_{AC} , and t_{CQV} . It is possible to bring /RE high after time t_{RE} since the new row data is safely latched into SRAM cache. This allows the EDRAM to precharge the DRAM array while data is accessed from SRAM cache. It is possible to access additional SRAM cache locations by providing new column addresses to the multiplex address inputs. New data is available at the output at time t_{AC} after each column address change in static column mode. During read cycles, it is possible to operate in either static column mode with /CAL=high or page mode with /CAL clocked to latch the column address. In page mode, data valid is determined by either t_{AC} or t_{CQV} .

DRAM Write Hit

If a DRAM write request is initiated by clocking /RE while W/R and /F are high, the EDRAM will compare the new row address to the LRR address latch (an 11-bit address latch loaded on each /RE active read). If the row address matches, the EDRAM will write data to both the DRAM array and selected SRAM cache simultaneously to maintain coherency. The write address and data are posted to the DRAM as soon as the column address is latched by bringing /CAL low and the write data is latched by bringing /WE low (both /CAL and /WE must be high when initiating the write cycle with the falling edge of /RE). The write address and data can be latched very quickly after the fall of /RE ($t_{RAH} + t_{ASC}$ for the column address and t_{DS} for the data). During a write burst sequence, the second write data can be posted at time t_{RSW} after /RE. Subsequent writes within a page can occur with write cycle time t_{PC} . With /G enabled and /WE disabled, it is possible to perform cache read operations while the /RE is activated in write hit mode. This allows read-modify-write, write-verify, or random read-write sequences within the page with 15ns cycle times (the first read cannot complete until after time t_{RAC2}). At the end of a write sequence (after /CAL and /WE are brought high and t_{RE} is satisfied), /RE can be brought high to precharge the memory. It is possible to perform cache reads

concurrently with precharge. During write sequences, a write operation is not performed unless both /CAL and /WE are low. As a result, the /CAL input can be used as a byte write select in multi-chip systems. If /CAL is not clocked on a write sequence, the memory will perform a /RE only refresh to the selected row and data will remain unmodified.

DRAM Write Miss

If a DRAM write request is initiated by clocking /RE while W/R and /F are high, the EDRAM will compare the new row address to the LRR address latch (an 11-bit latch loaded on each /RE active read cycle). If the row address does not match, the EDRAM will write data to the DRAM array only and contents of the current cache is not modified. The write address and data are posted to the DRAM as soon as the column address is latched by bringing /CAL low and the write data is latched by bringing /WE low (both /CAL and /WE must be high when initiating the write cycle with the falling edge of /RE). The write address and data can be latched very quickly after the fall of /RE ($t_{RAH} + t_{ASC}$ for the column address and t_{DC} for the data). During a write burst sequence, the second write data can be posted at time t_{RSW} after /RE. Subsequent writes within a page can occur with write cycle time t_{PC} . During a write miss sequence, cache reads are inhibited and the output buffers are disabled (independently of /G) until time t_{WRR} after /RE goes high. At the end of a write sequence (after /CAL and /WE are brought high and t_{RE} is satisfied), /RE can be brought high to precharge the memory. It is possible to perform cache reads concurrently with the precharge. During write sequences, a write operation is not performed unless both /CAL and /WE are low. As a result, /CAL can be used as a byte write select in multi-chip systems. If /CAL is not clocked on a write sequence, the memory will perform a /RE only refresh to the selected row and data will remain unmodified.

/RE Inactive Operation

It is possible to read data from the SRAM cache without clocking /RE. This option is desirable when the external control logic is capable of fast hit/miss comparison. In this case, the controller can avoid the time required to perform row/column multiplexing on hit cycles. This capability also allows the EDRAM to perform cache read operations during precharge and refresh cycles to minimize wait states. It is only necessary to select /S and /G and provide the appropriate column address to read data as shown in the table below. The row address of the SRAM cache accessed without clocking /RE will be specified by the LRR address latch loaded during the last /RE active read cycle. To perform a cache read in static column mode, /CAL is held high, and the cache contents at the specified column address will be valid at time t_{AC} after address is stable. To perform a cache read in page mode, /CAL is clocked to latch the column address. The cache data is valid at time t_{AC} after the column address is setup to /CAL.

Function	/S	/G	/CAL	A_{0-9}
Cache Read (Static Column)	L	L	H	Column Address
Cache Read (Page Mode)	L	L	↓	Column Address

H = High; L = Low; X = Don't Care; ↓ = Transitioning

Write-Per-Bit Operation

The DM1M36SJ EDRAM SIMM provides a write-per-bit capability to selectively modify individual parity bits ($DQ_{8,17,26,35}$) for byte write operations. The parity device (DM2212) is selected via /CAL_p. Data bits do not require or support write-per-bit capability. Byte write selection to non-parity bits is accomplished via /CAL₀₋₃. The bits to be written are determined by a bit mask data word which is placed on the parity I/O data pins prior to clocking /RE. The logic one bits in the mask data select the bits to be written. As soon as the mask is latched by /RE, the mask data is removed and write data can be placed on the databus. The mask is only specified on the /RE transition. During page mode burst write operations, the same mask is used for all write operations.

Internal Refresh

If /F is active (low) on the assertion of /RE, an internal refresh cycle is executed. This cycle refreshes the row address supplied by an internal refresh counter. This counter is incremented at the end of the cycle in preparation for the next /F refresh cycle. At least 1,024 /F cycles must be executed every 64ms. /F refresh cycles can be hidden because cache memory can be read under column address control throughout the entire /F cycle. /F cycles are the only active cycles during which /S can be disabled.

/CAL Before /RE Refresh ("CAS Before /RAS")

/CAL before /RE refresh, a special case of internal refresh, is discussed in the "Reduced Pin Count Operation" section below.

/RE Only Refresh Operation

Although /F refresh using the internal refresh counter is the recommended method of EDRAM refresh, it is possible to perform an /RE only refresh using an externally supplied row address. /RE refresh is performed by executing a write cycle (W/R and /F are high) where /CAL is not clocked. This is necessary so that the current cache contents and LRR are not modified by the refresh operation. All combinations of addresses A_{0-9} must be sequenced every 64ms refresh period. A_{10} does not need to be cycled. Read refresh cycles are not allowed because a DRAM refresh cycle does not occur when a read refresh address matches the LRR address latch.

Low Power Mode

The EDRAM enters its low power mode when /S is high. In this mode, the internal DRAM circuitry is powered down to reduce standby current.

Initialization Cycles

A minimum of 10 initialization (start-up) cycles are required before normal operation is guaranteed. A combination of eight /F refresh cycles and two read cycles to different row addresses are necessary to complete initialization.

Unallowed Mode

Read, write, or /RE only refresh operations must not be initiated to unselected memory banks by clocking /RE when /S is high.

Reduced Pin Count Operation

It is possible to simplify the interface to the 4MByte SIMM to reduce the number of control lines. /RE₀ and /RE₂ could be tied together externally to provide a single row enable. W/R and /G can be tied together if reads are not performed during write hit cycles. This external wiring simplifies the interface without any performance impact.

Interconnect Diagram

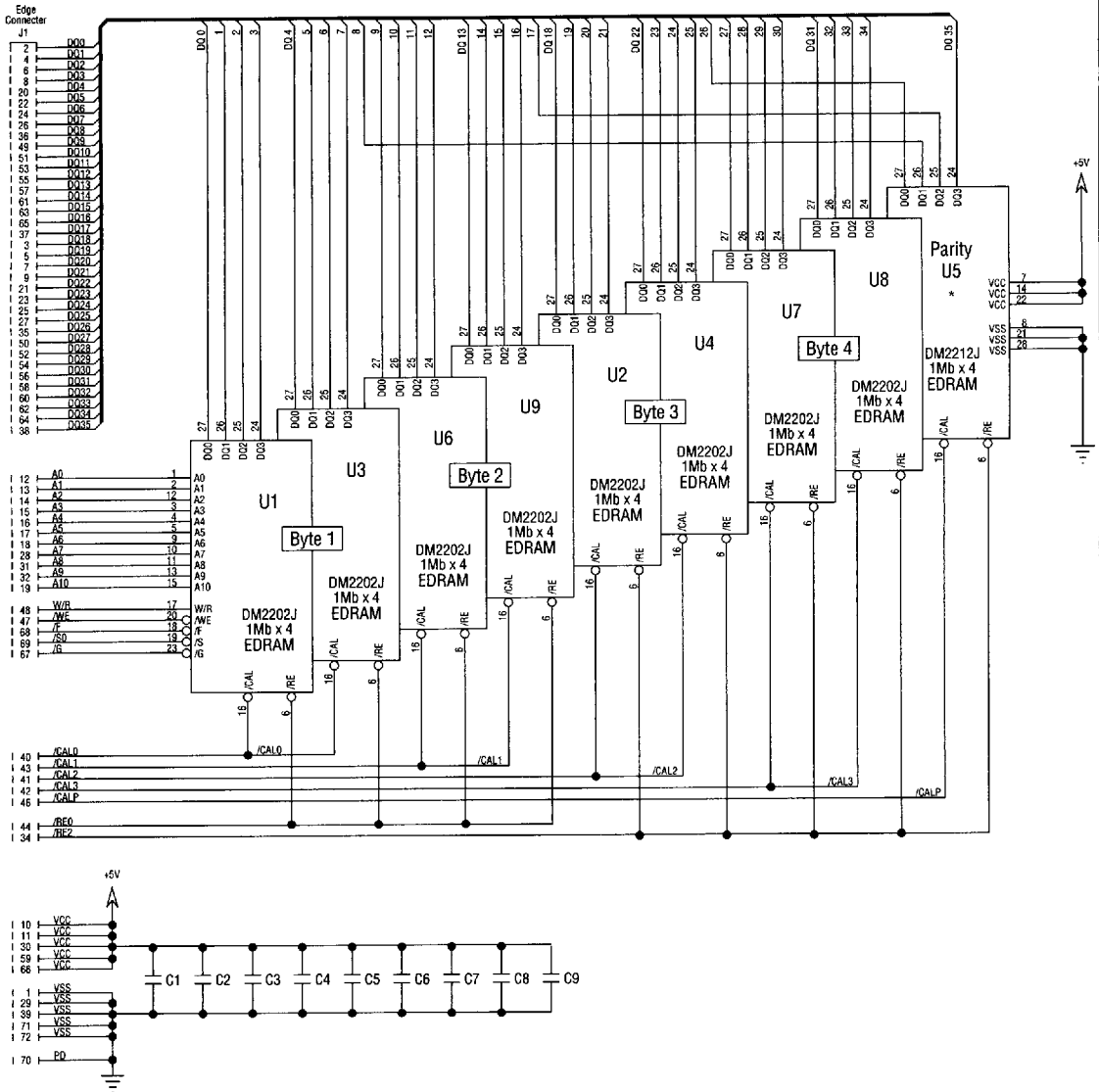

*DM2212 is not present on the DM2M32SJ.

Pinout

Pin No.	Function	Interconnect (Component Pin)	Organization
1	GND	C (8, 21, 28)	Ground
2	DQ ₀	U1 (27)	Byte 1 I/O 1
3	DQ ₁₈	U2 (24)	Byte 3 I/O 1
4	DQ ₁	U1 (26)	Byte 1 I/O 2
5	DQ ₁₉	U2 (25)	Byte 3 I/O 2
6	DQ ₂	U1 (25)	Byte 1 I/O 3
7	DQ ₂₀	U2 (26)	Byte 3 I/O 3
8	DQ ₃	U1 (24)	Byte 1 I/O 4
9	DQ ₂₁	U2 (27)	Byte 3 I/O 4
10	+5 Volts	C (7, 14, 22)	V _{CC}
11	+5 Volts	C (7, 14, 22)	V _{CC}
12	A ₀	C (1)	Address
13	A ₁	C (2)	Address
14	A ₂	C (12)	Address
15	A ₃	C (3)	Address
16	A ₄	C (4)	Address
17	A ₅	C (5)	Address
18	A ₆	C (9)	Address
19	A ₁₀	C (15)	Address
20	DQ ₄	U3 (27)	Byte 1 I/O 5
21	DQ ₂₂	U4 (24)	Byte 3 I/O 5
22	DQ ₅	U3 (26)	Byte 1 I/O 6
23	DQ ₂₃	U4 (25)	Byte 3 I/O 6
24	DQ ₆	U3 (25)	Byte 1 I/O 7
25	DQ ₂₄	U4 (26)	Byte 3 I/O 7
26	DQ ₇	U3 (24)	Byte 1 I/O 8
27	DQ ₂₅	U4 (27)	Byte 3 I/O 8
28	A ₇	C (10)	Address
29	GND	C (8, 21, 28)	Ground
30	+5 Volts	C (7, 14, 22)	V _{CC}
31	A ₈	C (11)	Address
32	A ₉	C (13)	Address
33	NC		Reserved for 2Mb x 36
34	/RE ₂	U2,4,5,7,8 (6)	Row Enable (Bytes 3,4, Parity)
35	DQ ₂₆ *	U5 (27)	Parity I/O for Byte 3
36	DQ ₈ *	U5 (26)	Parity I/O for Byte 1

Pin No.	Function	Interconnect (Component Pin)	Organization
37	DQ ₁₇ *	U5 (25)	Parity I/O for Byte 2
38	DQ ₃₅ *	U5 (24)	Parity I/O for Byte 4
39	GND	C (8, 21, 28)	Ground
40	/CAL ₀	U1,3 (16)	Byte 1 Column Address Latch
41	/CAL ₂	U2,4 (16)	Byte 3 Column Address Latch
42	/CAL ₃	U7,8 (16)	Byte 4 Column Address Latch
43	/CAL ₁	U6,9 (16)	Byte 2 Column Address Latch
44	/RE ₀	U1,3,6,9 (6)	Row Enable (Bytes 1,2)
45	NC		Reserved for 2Mb x 36
46	/CAL _P *	U5 (16)	Parity Column Address Latch
47	/WE	C (20)	Write Enable
48	W/R	C (17)	W/R Mode Control
49	DQ ₉	U6 (27)	Byte 2 I/O 1
50	DQ ₂₇	U7 (27)	Byte 4 I/O 1
51	DQ ₁₀	U6 (26)	Byte 2 I/O 2
52	DQ ₂₈	U7 (26)	Byte 4 I/O 2
53	DQ ₁₁	U6 (25)	Byte 2 I/O 3
54	DQ ₂₉	U7 (25)	Byte 4 I/O 3
55	DQ ₁₂	U6 (24)	Byte 2 I/O 4
56	DQ ₃₀	U7 (24)	Byte 4 I/O 4
57	DQ ₁₃	U9 (24)	Byte 2 I/O 5
58	DQ ₃₁	U8 (27)	Byte 4 I/O 5
59	+5 Volts	C (7, 14, 22)	V _{CC}
60	DQ ₃₂	U8 (26)	Byte 4 I/O 6
61	DQ ₁₄	U9 (25)	Byte 2 I/O 6
62	DQ ₃₃	U8 (25)	Byte 4 I/O 7
63	DQ ₁₅	U9 (26)	Byte 2 I/O 7
64	DQ ₃₄	U8 (24)	Byte 4 I/O 8
65	DQ ₁₆	U9 (27)	Byte 2 I/O 8
66	+5 Volts	C (7, 14, 22)	V _{CC}
67	/G	C (23)	Output Enable
68	/F	C (18)	Refresh Mode Control
69	/S	C (19)	Chip Select
70	PD	Signal GND	Presence Detect
71	GND	C (8, 21, 28)	Ground
72	GND	C (8, 21, 28)	Ground

C = Common to All Memory Chips, U1 = Chip 1, etc.

*No Connect for DM1M32SJ

Pin Descriptions

***/RE_{0,2}* — Row Enable**

This input is used to initiate DRAM read and write operations and latch a row address as well as the states of */W/R* and */F*. It is not necessary to clock */RE* to read data from the EDRAM SRAM row registers. On read operations, */RE* can be brought high as soon as data is loaded into cache to allow early precharge.

***/CAL_{0,3,P}* — Column Address Latch**

This input is used to latch the column address and in combination with */WE* to trigger write operations. When */CAL* is high, the column address latch is transparent. When */CAL* is low, the column address is closed and the output of the latch contains the address present while */CAL* was high. */CAL* can be toggled when */RE* is low or high. However, */CAL* must be high during the high-to-low transition of */RE* except for */F* refresh cycles.

***W/R* — Write/Read**

This input along with */F* specifies the type of DRAM operation initiated on the low going edge of */RE*. When */F* is high, *W/R* specifies either a write (logic high) or read operation (logic low).

***/F* — Refresh**

This input will initiate a DRAM refresh operation using the internal refresh counter as an address source when it is low on the low going edge of */RE*.

***/WE* — Write Enable**

This input controls the latching of write data on the input data pins. A write operation is initiated when both */CAL* and */WE* are low.

Absolute Maximum Ratings

(Beyond Which Permanent Damage Could Result)

Description	Ratings
Input Voltage (V_{IN})	-1 ~ 7V
Output Voltage (V_{OUT})	-1 ~ 7V
Power Supply Voltage (V_{CC})	-1 ~ 7V
Ambient Operating Temperature (T_A)	0 ~ 70°C
Storage Temperature (T_S)	-55 ~ 150°C
Static Discharge Voltage (Per MIL-STD-883 Method 3015)	>2000V
Short Circuit O/P Current (I_{OUT})	50mA*

* One output at a time per device; short duration

***/G* — Output Enable**

This input controls the gating of read data to the output data pin during read operations.

***/S* — Chip Select**

This input is used to power up the I/O and clock circuitry. When */S* is high, the EDRAM remains in its low power mode. */S* must remain active throughout any read or write operation. With the exception of */F* refresh cycles, */RE* should never be clocked when */S* is inactive.

***DQ₀₋₃₅* — Data Input/Output**

These bidirectional data pins are used to read and write data to the EDRAM. On the DM2212 write-per-bit memory, these pins are also used to specify the bit mask used during write operations.

***A₀₋₁₀* — Multiplex Address**

These inputs are used to specify the row and column addresses of the EDRAM data. The 11-bit row address is latched on the falling edge of */RE*. The 9-bit column address can be specified at any other time to select read data from the SRAM cache or to specify the write column address during write cycles.

V_{CC} Power Supply

These inputs are connected to the +5 volt power supply.

V_{SS} Ground

These inputs are connected to the power supply ground connection.

Capacitance

Description	Max*	Pins
Input Capacitance	66/73pf	A_{0-9}
Input Capacitance	90/100pf	A_{10} , <i>W/R</i> , <i>/WE</i> , <i>/F</i> , <i>/S</i>
Input Capacitance	45pf	$/RE_0$
Input Capacitance	46/56pf	$/RE_2$
Input Capacitance	26/28pf	<i>/G</i>
Input Capacitance	24pf	$/CAL_{0-3}$
Input Capacitance	12pf	$/CAL_P$
I/O Capacitance	8pf	DQ_{0-35}

* DM1M32SJ/DM1M36SJ, respectively

AC Test Load and Waveforms

Load Circuit

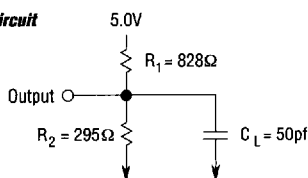

Input Waveforms

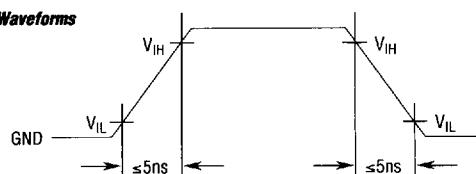

V_{IN} Timing Reference Point at V_{IL} and V_{IH}

Electrical Characteristics

($T_A = 0 - 70^\circ\text{C}$)

Symbol	Parameters	Min	Max	Test Conditions
V_{CC}	Supply Voltage	4.75V	5.25V	All Voltages Referenced to V_{SS}
V_{IH}	Input High Voltage	2.4V	6.5V	
V_{IL}	Input Low Voltage	-1.0V	0.8V	
V_{OH}	Output High Level	2.4V	—	$I_{OUT} = -5\text{mA}$
V_{OL}	Output Low Level	—	0.4V	$I_{OUT} = 4.2\text{mA}$
$I_{I(L)}$	Input Leakage Current	-10 μA	10 μA	$0\text{V} \leq V_{IN} \leq 6.5\text{V}$, All Other Pins Not Under Test = 0V
$I_{O(L)}$	Output Leakage Current	-10 μA	10 μA	$0\text{V} \leq V_{IN}$, $0\text{V} \leq V_{OUT} \leq 5.5\text{V}$

Operating Current — DM1M32SJ

Symbol	Operating Current	33MHz Typ ⁽¹⁾	-15 Max	-20 Max	Test Condition	Notes
I_{CC1}	Random Read	880mA	1800mA	1440mA	/RE, /CAL, /G and Addresses Cycling: $t_C = t_C$ Minimum	2, 3
I_{CC2}	Fast Page Mode Read	520mA	1160mA	920mA	/CAL, /G and Addresses Cycling: $t_{PC} = t_{PC}$ Minimum	2, 4
I_{CC3}	Static Column Read	440mA	880mA	720mA	/G and Addresses Cycling: $t_{SC} = t_{SC}$ Minimum	2, 4
I_{CC4}	Random Write	1080mA	1520mA	1200mA	/RE, /CAL, /WE and Addresses Cycling: $t_C = t_C$ Minimum	2, 3
I_{CC5}	Fast Page Mode Write	400mA	1080mA	840mA	/CAL, /WE and Addresses Cycling: $t_{PC} = t_{PC}$ Minimum	2, 4
I_{CC6}	Standby	8mA	8mA	8mA	All Control Inputs Stable $\geq V_{CC} - 0.2\text{V}$	
I_{CCT}	Average Typical Operating Current	240mA	—	—	See "Estimating EDRAM Operating Power" Application Note	1

Operating Current — DM1M36SJ

Symbol	Operating Current	33MHz Typ ⁽¹⁾	-15 Max	-20 Max	Test Condition	Notes
I_{CC1}	Random Read	990mA	2025mA	1620mA	/RE, /CAL, /G and Addresses Cycling: $t_C = t_C$ Minimum	2, 3
I_{CC2}	Fast Page Mode Read	585mA	1305mA	1035mA	/CAL, /G and Addresses Cycling: $t_{PC} = t_{PC}$ Minimum	2, 4
I_{CC3}	Static Column Read	495mA	990mA	810mA	/G and Addresses Cycling: $t_{SC} = t_{SC}$ Minimum	2, 4
I_{CC4}	Random Write	1215mA	1710mA	1350mA	/RE, /CAL, /WE and Addresses Cycling: $t_C = t_C$ Minimum	2, 3
I_{CC5}	Fast Page Mode Write	450mA	1215mA	945mA	/CAL, /WE and Addresses Cycling: $t_{PC} = t_{PC}$ Minimum	2, 4
I_{CC6}	Standby	9mA	9mA	9mA	All Control Inputs Stable $\geq V_{CC} - 0.2\text{V}$, Outputs Driven	
I_{CCT}	Average Typical Operating Current	270mA	—	—	See "Estimating EDRAM Operating Power" Application Note	1

(1) "33MHz Typ" refers to worst case I_{CC} expected in a system operating with a 33MHz memory bus. See power applications note for further details. This parameter is not 100% tested or guaranteed.

(2) I_{CC} is dependent on cycle rates and is measured with CMOS levels and the outputs open.

(3) I_{CC} is measured with a maximum of one address change while /RE = V_{IL} .

(4) I_{CC} is measured with a maximum of one address change while /CAL = V_{IH} .

Switching Characteristics

Discrete devices have been tested from 4.7V to 5.3V V_{CC} and to 75°C to guarantee SIMM specifications. ($V_{CC} = 5V \pm 5\%$, $T_A = 0$ to 70°C, $C_L = 50\text{pf}$)

Symbol	Description	-15		-20		Units
		Min	Max	Min	Max	
$t_{AC}^{(1)}$	Column Address Access Time		15		20	ns
t_{ACH}	Column Address Valid to /CAL Inactive (Write Cycle)	15		20		ns
t_{AOX}	Column Address Change to Output Data Invalid	5		5		ns
t_{ASC}	Column Address Setup Time	5		5		ns
t_{ASR}	Row Address Setup Time	5		6		ns
t_C	Row Enable Cycle Time	65		85		ns
t_{C1}	Row Enable Cycle Time, Cache Hit (Row=LRR), Read Cycle Only	25		32		ns
t_{CAE}	Column Address Latch Active Time	6		7		ns
t_{CAH}	Column Address Hold Time	0		1		ns
t_{CH}	Column Address Latch High Time (Latch Transparent)	5		7		ns
t_{CHR}	/CAL Inactive Lead Time to /RE Inactive (Write Cycles Only)	-1		-1		ns
t_{CHW}	Column Address Latch High to Write Enable Low (Multiple Writes)	0		0		ns
t_{CQV}	Column Address Latch High to Data Valid		17		20	ns
t_{CQX}	Column Address Latch Inactive to Data Invalid	5		5		ns
t_{CRP}	Column Address Latch Setup Time to Row Enable	5		6		ns
t_{CWL}	/WE Low to /CAL Inactive	5		7		ns
t_{DH}	Data Input Hold Time	0		1		ns
t_{DMH}	Mask Hold Time From Row Enable (Write-Per-Bit)	1.5		2		ns
t_{DMS}	Mask Setup Time to Row Enable (Write-Per-Bit)	5		6		ns
t_{DS}	Data Input Setup Time	5		6		ns
$t_{GQV}^{(1)}$	Output Enable Access Time		5		6	ns
$t_{GQX}^{(2,3)}$	Output Enable to Output Drive Time	0	5	0	6	ns
$t_{GQZ}^{(4,5)}$	Output Turn-Off Delay From Output Disabled (/G \uparrow)	0	5	0	6	ns
t_{MH}	/F and W/R Mode Select Hold Time	0		1		ns
t_{MSU}	/F and W/R Mode Select Setup Time	5		6		ns
t_{NRH}	/CAL, /G, and /WE Hold Time For /RE-Only Refresh	0		0		ns
t_{NRS}	/CAL, /G, and /WE Setup Time For /RE-Only Refresh	5		6		ns
t_{PC}	Column Address Latch Cycle Time	15		20		ns
$t_{RAC}^{(1)}$	Row Enable Access Time, On a Cache Miss		35		45	ns
$t_{RAC1}^{(1)}$	Row Enable Access Time, On a Cache Hit (Limit Becomes t_{AC})		17		22	ns
$t_{RAC2}^{(1,6)}$	Row Enable Access Time for a Cache Write Hit		35		45	ns
t_{RAH}	Row Address Hold Time	1.5		2		ns
t_{RE}	Row Enable Active Time	35	100000	45	100000	ns

Switching Characteristics (continued)

Discrete devices have been tested from 4.7V to 5.3V V_{CC} and to 75°C to guarantee SIMM specifications. ($V_{CC} = 5V \pm 5\%$, $T_A = 0$ to 70°C, $C_L = 50$ pf)

Symbol	Description	-15		-20		Units
		Min	Max	Min	Max	
t_{RE1}	Row Enable Active Time, Cache Hit (Row=LRR) Read Cycle	10		13		ns
t_{REF}	Refresh Period		64		64	ms
t_{RGX}	Output Enable Don't Care From Row Enable (Write, Cache Miss), O/P Hi Z	10		13		ns
t_{ROX1}	Row Enable High to Output Turn-On After Write Miss		15		20	ns
$t_{RP}^{(7)}$	Row Precharge Time	25		32		ns
t_{RP1}	Row Precharge Time, Cache Hit (Row=LRR) Read Cycle	10		13		ns
t_{RRH}	Read Hold Time From Row Enable (Write Only)	0		1		ns
t_{RSH}	Last Write Address Latch to End of Write	15		20		ns
t_{RSW}	Row Enable to Column Address Latch Low For Second Write	40		51		ns
t_{RWL}	Last Write Enable to End of Write	15		20		ns
t_{SC}	Column Address Cycle Time	15		20		ns
t_{SHR}	Select Hold From Row Enable	0		1		ns
$t_{SQV}^{(1)}$	Chip Select Access Time		15		20	ns
$t_{SQX}^{(2,3)}$	Output Turn-On From Select Low	0	15	0	20	ns
$t_{SQZ}^{(4,5)}$	Output Turn-Off From Chip Select	0	10	0	13	ns
t_{SSR}	Select Setup Time to Row Enable	5		6		ns
t_T	Transition Time (Rise and Fall)	1	10	1	10	ns
t_{WC}	Write Enable Cycle Time	15		20		ns
t_{WCH}	Column Address Latch Low to Write Enable Inactive Time	5		7		ns
$t_{WHR}^{(8)}$	Write Enable Hold After /RE	0		1		ns
t_{WI}	Write Enable Inactive Time	5		7		ns
t_{WP}	Write Enable Active Time	5		7		ns
$t_{WQV}^{(1)}$	Data Valid From Write Enable High		15		20	ns
$t_{WQX}^{(2,5)}$	Data Output Turn-On From Write Enable High	0	15	0	20	ns
$t_{WQZ}^{(3,4)}$	Data Turn-Off From Write Enable Low	0	15	0	20	ns
t_{WRP}	Write Enable Setup Time to Row Enable	5		5		ns
t_{WRR}	Write to Read Recovery (Following Write Miss)		18		20	ns

(1) V_{OUT} Timing Reference Point at 1.5V

(2) Parameter Defines Time When Output is Enabled (Sourcing or Sinking Current) and is Not Referenced to V_{OH} or V_{OL}

(3) Minimum Specification is Referenced from V_{IH} and Maximum Specification is Referenced from V_{IL} on Input Control Signal

(4) Parameter Defines Time When Output Achieves Open-Circuit Condition and is Not Referenced to V_{OH} or V_{OL}

(5) Minimum Specification is Referenced from V_{IH} and Maximum Specification is Referenced from V_{IL} on Input Control Signal

(6) Access Parameter Applies When /CAL Has Not Been Asserted Prior to t_{RACZ}

(7) For Back-to-Back /F Refreshes, $t_{RP} = 40$ ns. For Non-consecutive /F Refreshes, $t_{RP} = 25$ ns and 32ns Respectively

(8) For Write-Per-Bit Devices, t_{WHR} is Limited By Data Input Setup Time, t_{DS}

/RE Inactive Cache Read Hit (Static Column Mode)

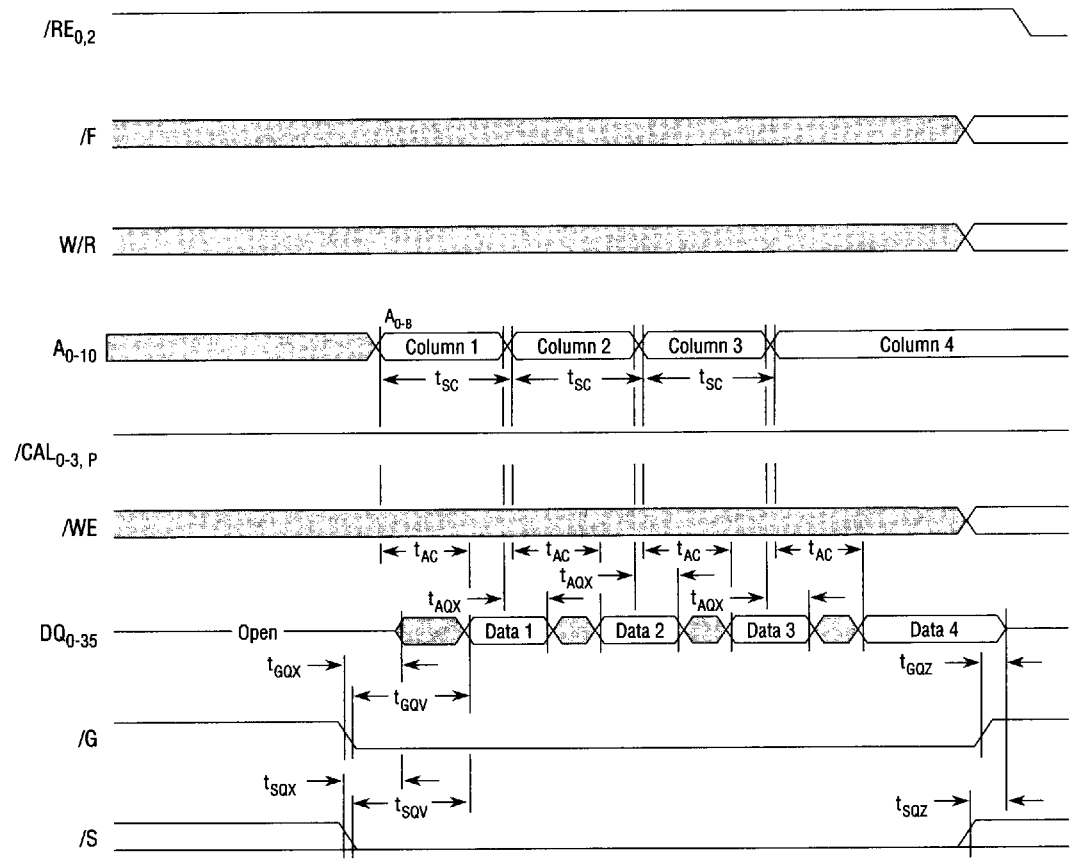

Don't Care or Indeterminate

NOTES: 1. Data accessed during /RE inactive read is from the row address specified during the last /RE active read cycle.

/RE Inactive Cache Read Hit (Page Mode)

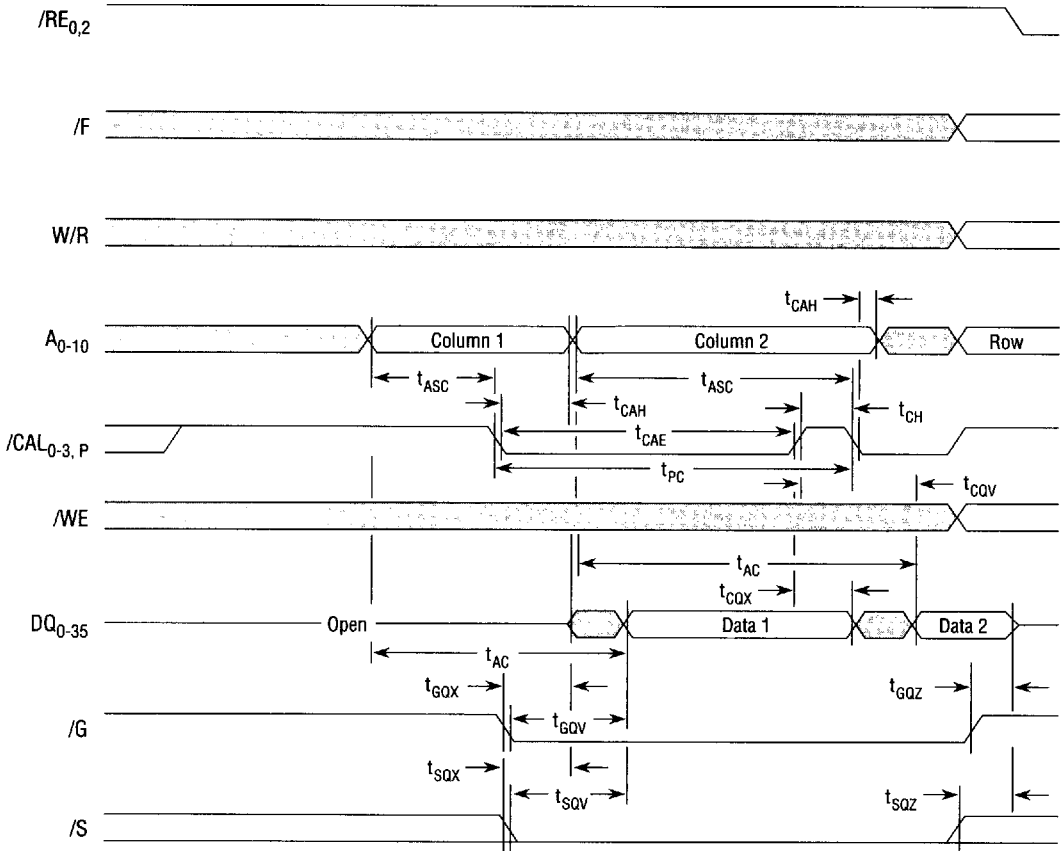

Don't Care or Indeterminate

NOTES: 1. Data accessed during /RE inactive read is from the row address specified during the last /RE active read cycle.

/RE Active Cache Read Hit (Static Column Mode)

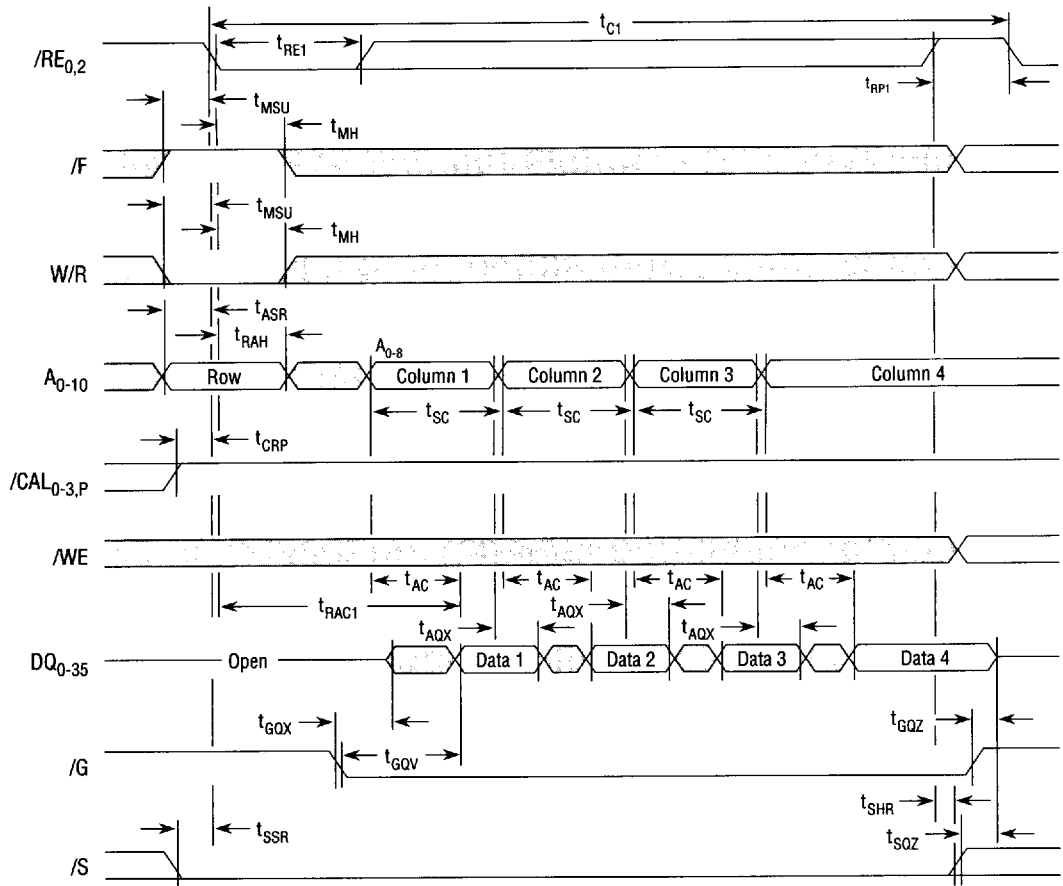

Don't Care or Indeterminate

/RE Active Cache Read Hit (Page Mode)

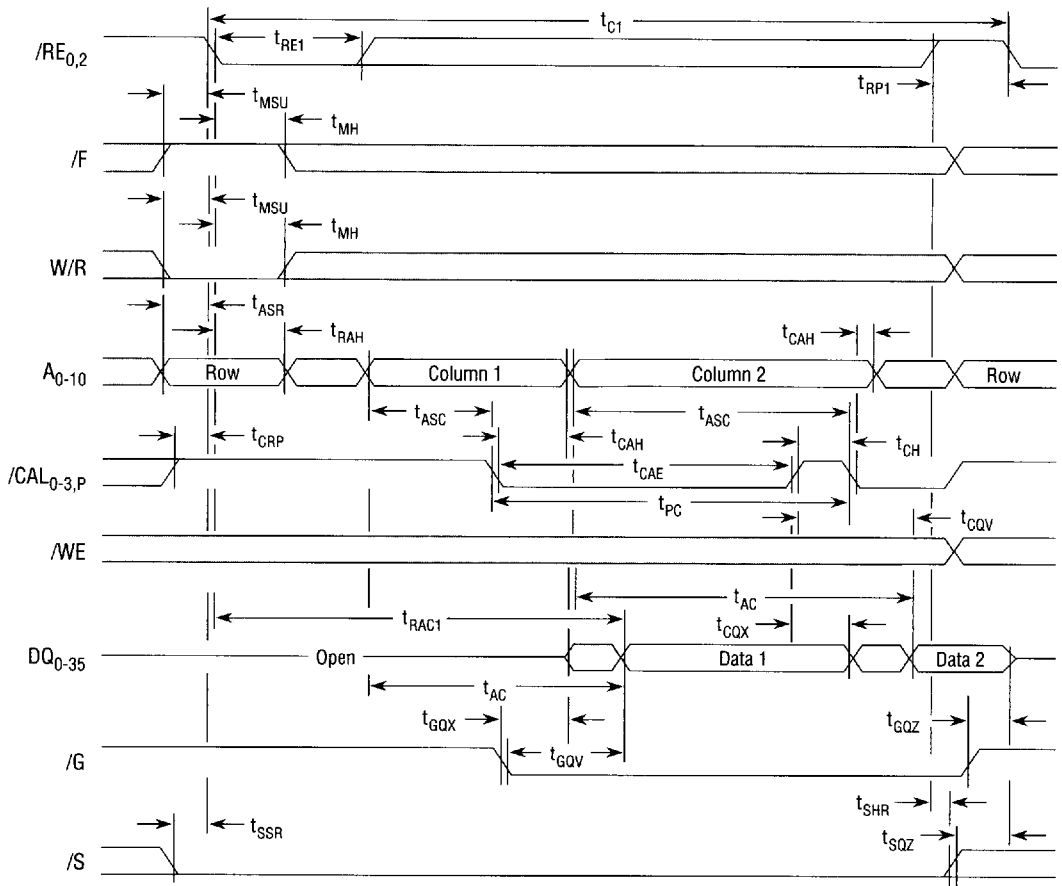

Don't Care or Indeterminate

/RE Active Cache Read Miss (Static Column Mode)

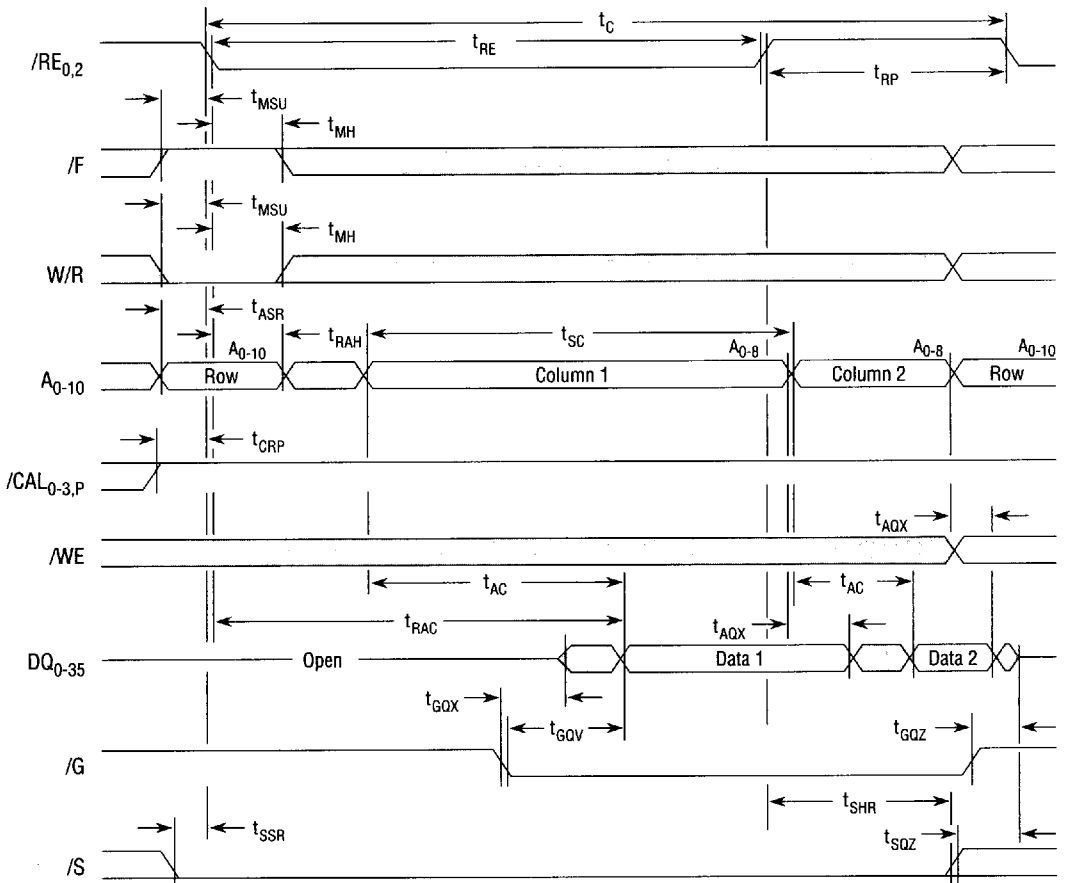

Don't Care or Indeterminate

/RE Active Cache Read Miss (Page Mode)

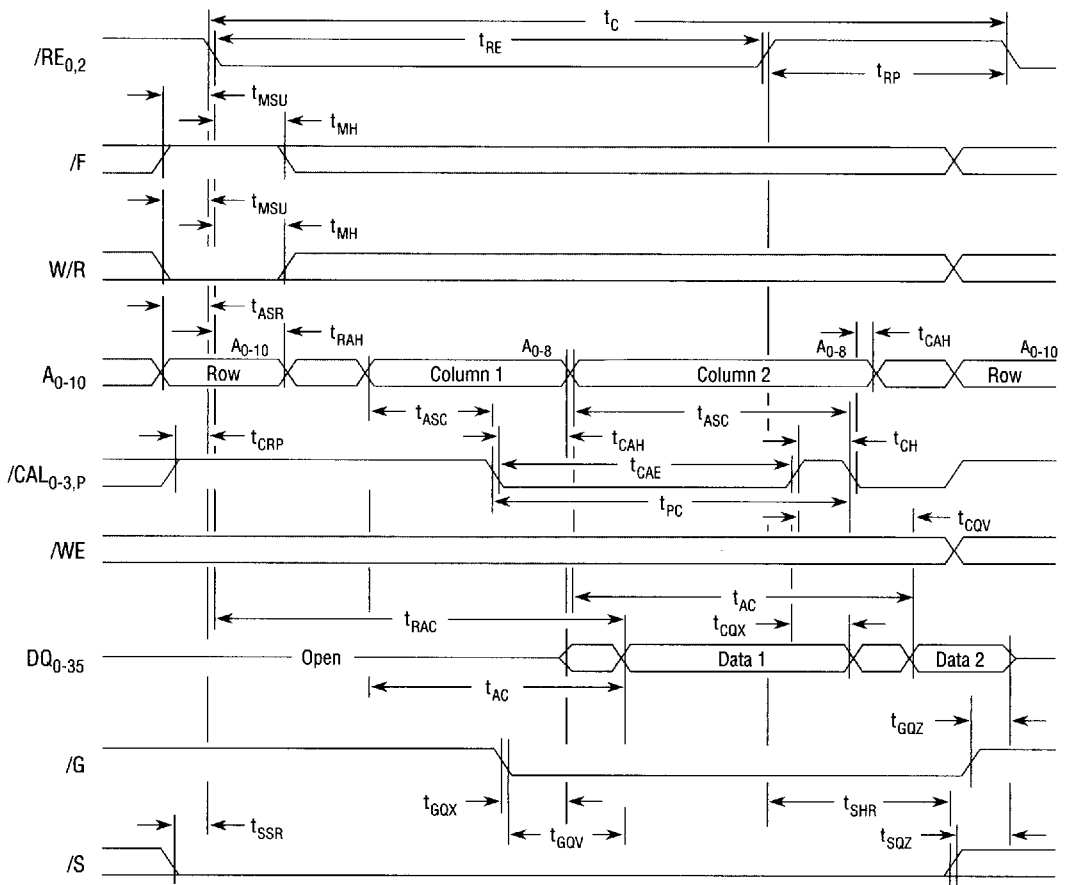

Don't Care or Indeterminate

Burst Write (Hit or Miss) Followed By /RE Inactive Cache Reads

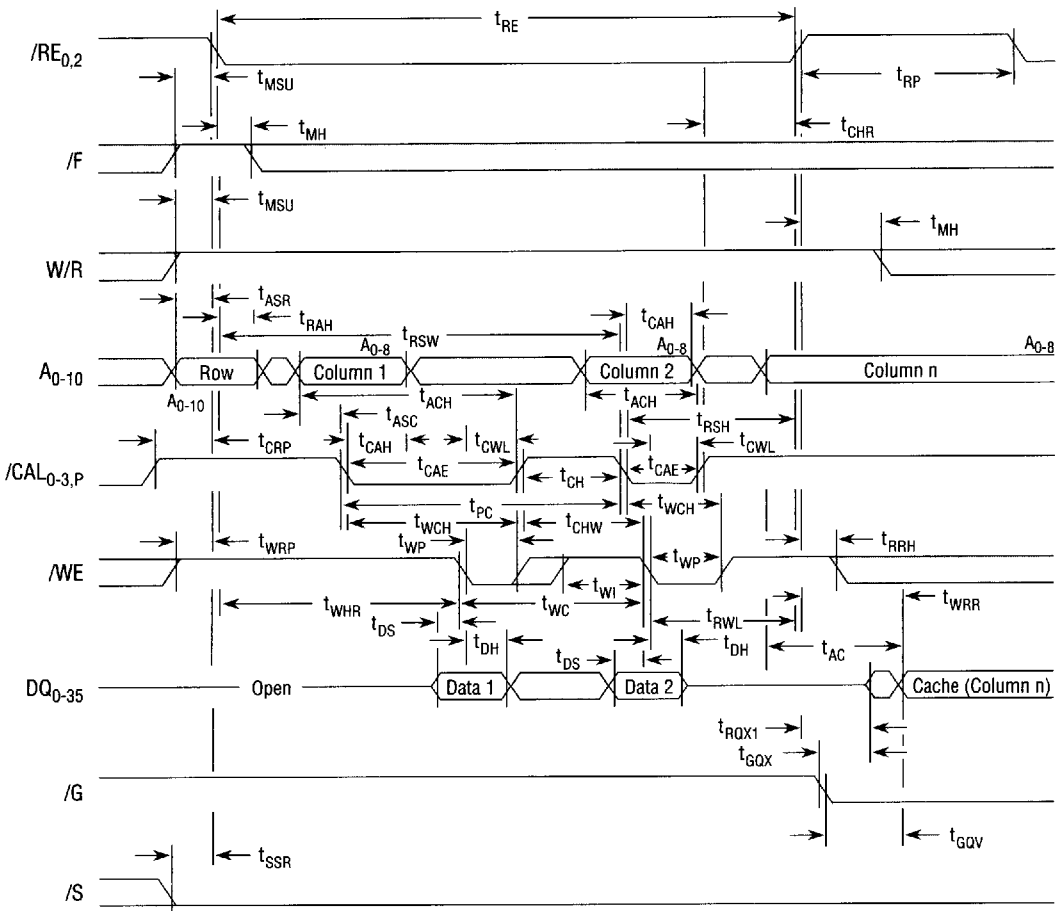

Don't Care or Indeterminate

- NOTES: 1. Parity bits DQ_{8,17,26,35} must have mask provided at falling edge of /RE.
 2. /G becomes a don't care after t_{RCX} during a write miss.

Write-Per-Bit Cycle (/G = High)

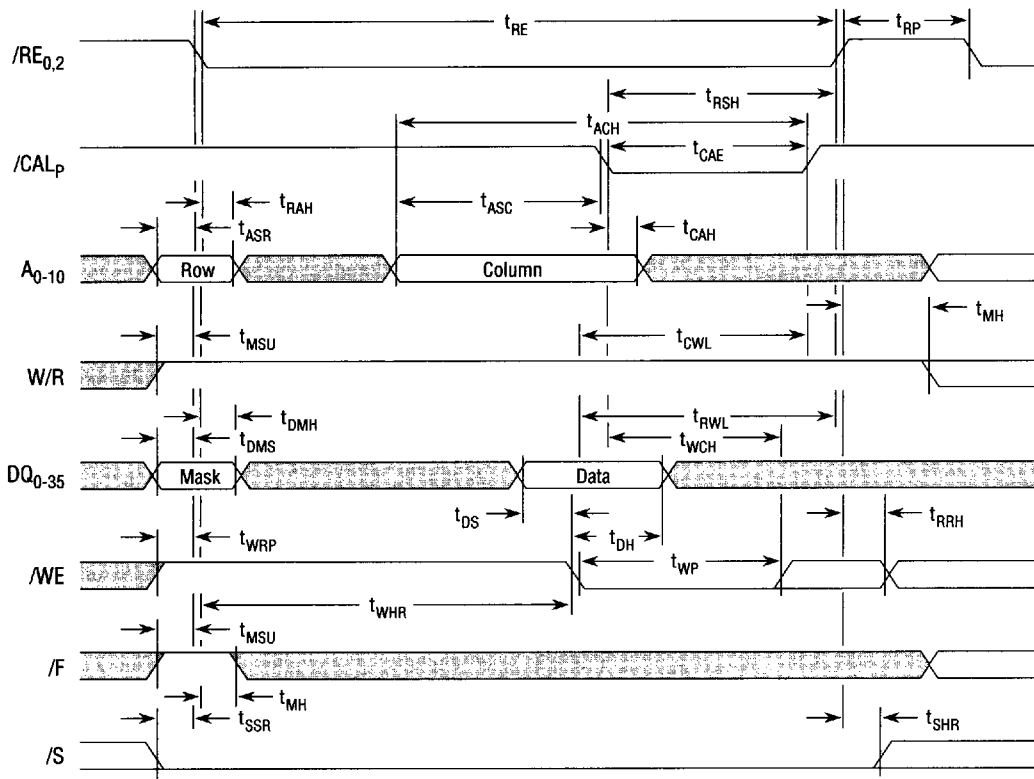

Don't Care or Indeterminate

- NOTES:
1. Data mask bit high (1) enables bit write; data mask bit low (0) inhibits bit write.
 2. Write-per-bit cycle valid only for DM1M36SJ.
 3. Write-per-bit waveform applies to parity bits (DQ_{8,17,26,35}).

/F Refresh Cycle

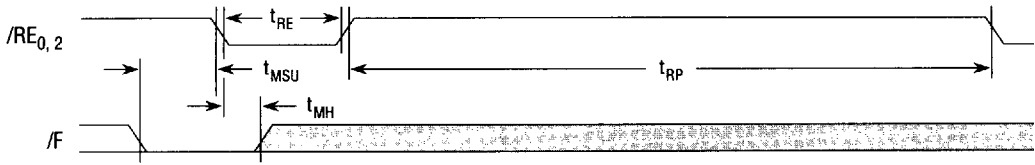

Don't Care or Indeterminate

- NOTES: 1. During \overline{F} refresh cycles, the status of $\overline{W/R}$, \overline{WE} , A_{0-10} , \overline{CAL} , \overline{S} , and \overline{G} is a don't care.
 2. \overline{RE} inactive cache reads may be performed in parallel with \overline{F} refresh cycles.

/RE-Only Refresh

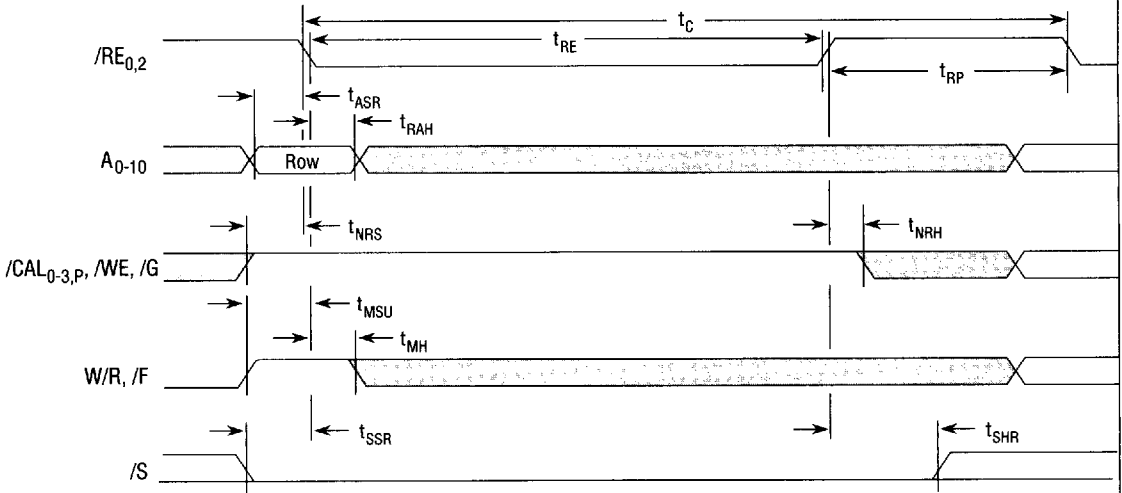

Don't Care or Indeterminate

- NOTES: 1. All binary combinations of A_{0-9} must be refreshed every 64ms interval. A_{10} does not have to be cycled, but must remain valid during row address setup and hold times.
 2. \overline{RE} refresh is write cycle with no \overline{CAL} active cycle.

9007247 0000108 668

Mechanical Data
72 Pin SIMM Module

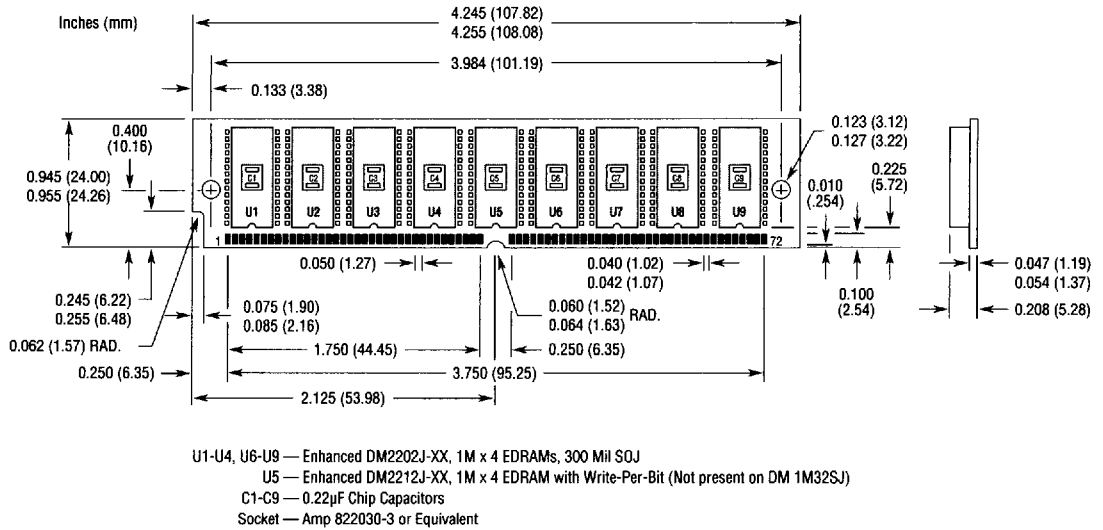

Part Numbering System

DM1M36SJ - 15

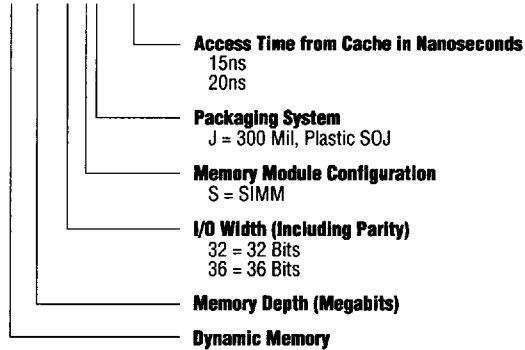

The information contained herein is subject to change without notice. Enhanced Memory Systems Inc. assumes no responsibility for the use of any circuitry other than circuitry embodied in an Enhanced product, nor does it convey or imply any license under patent or other rights.