



厦门华联电子有限公司
Xi amen Hual ian Elect. co. , l td

产品规格书

Speci fi cati on on Product

产 品 名 称 : 红外遥控接收放大器
(DESCRIPTION) : INFRARED MODULE FOR REMOTE CONTROL SYSTEM
产 品 型 号 (MODEL) : HRM1××AA1700 系列

TEL: (0592) 6037469

FAX: (0592) 6037471

E-mail: xmhl ec@publ i c. xm. com

Website: www.xmhl . com

ADDRESS: 厦门火炬高技术产业开发区华联电子大厦

P. C : 361006

● 概述 (General) :

红外遥控接收放大器是将光探测器与前置放大器封装在一起,以实现遥控信号的接收放大。环氧封装可滤除可见光干扰,检波输出信号可直接由微处理器译码,主要用于电视机、录像机、VCD、卫星接收机、空调器等领域。

Infrared module for remote control system which is PIN diode and preamplifier series are assembled on lead frame, in order to realize the receiving and amplifying the infrared remote controller signal. The type of epoxy package can filter the visual interference. The demodulated output signal can directly be decoded by a microprocessor. It may be used in TV sets、video recorder、VCD、satellite receivers、air conditioners etc.

● Parts Table

Type	fo	type	fo	type	fo
HRM133AA1700	32.7KHz	HRM137AA1700	36.7KHz	HRM138AA1700	37.9KHz
HRM140AA1700	40KHz	HRM157AA1700	56.7KHz		

● 特点 (Features):

- ◆ 没有外围元件,可靠性高 (No external parts, high reliability)
- ◆ 内部屏蔽,抗干扰能力强 (Inner shield, good anti-interference ability)
- ◆ 3~5V 供电电压,功耗低 (3~5V supplied voltage, low power consumption)
- ◆ 灵敏度高,传输范围大 (High sensitivity, large transmission range)
- ◆ TTL 和 CMOS 兼容 (Capability of TTL & CMOS)

● 极限参数 (Ta=25°C) (Absolute Maximum Ratings, Ta=25°C)

表一 (Table 1)

参数 Parameters	符号 Symbol	额定值 Rated value	单位 Unit
电源电压 Supply voltage	V _s	6.0	V
输出吸收电流 Output sink current	I _o	2.5	mA
工作温度 Operation Temp.	T _{amb}	-25~+85	°C
贮存温度 Storage Temp.	T _{stg}	-25~+85	°C
焊接温度 (5 秒) Soldering Temp. (5s)	T _{sd}	+260	°C

● 光电参数 (Ta=25°C) (Opto-electric characteristics, Ta=25°C)

表二 (Table 2)

参数 Parameters	符号 symbol	测试条件 Test condition	最小值 Min.	典型值 Typ.	最大值 Max.	单位 Unit
电源电流 Supply current	I _{CC}	V _s =5V E _v =0		1.0	1.5	mA
峰值波长 Peak wavelength	λ _p			940		nm
调制频率 Modulated freq.	f ₀			可选择 optional		KHz
高电平输出电压 High output voltage	V _{OH}	E _v =0.5mw/m ² 周期=1.2ms (Cycle=1.2ms) 占空比=50% (Duty=50%)	4.5			V
低电平输出电压 Low output voltage	V _{OL}				0.4	V
高电平输出脉宽 High output pulse width	T _{Wh}		500	600	700	μS
低电平输出脉宽 Low output pulse width	T _{wl}		500	600	700	μS
接收距离 Receiving distance	L	V _s =5V E _v =(200±50)Lx	15			M
受控角 Controlled angle	Δθ	V _s =5V E _v =(200±50)Lx L=6.5M		±45		deg

● 标识 (Mark)

在产品背面打印产品型号和生产批号, 如下:

Print type model and LOT.NO. on the back of product as follow:

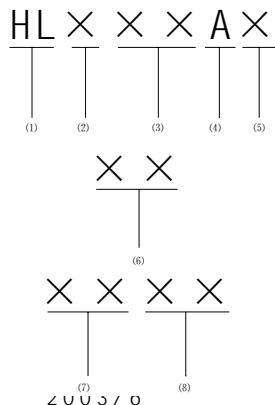

- (1): 华联标志 (HL mark)
- (2): 工作电压 (Operation voltage)
- (3): 调制频率 (Modulated frequency)
- (4): 封装形式 (Packaging model)
- (5): 引脚排列 (Pin arrangement)
- (6): 芯片代码 (IC chip code)
- (7): 生产年 (Production year)
- (8): 生产月 (Production month)



● 包装 (Package)

包装采用防静电塑料条管和外包装纸箱，外包装箱上应有符合 GB191 中规定的相应运输要求的标志以及标明公司名称、商标、地址、产品名称、型号、数量等，并贴有封讫，箱内应有合格证，标明型号、生产日期及检验员代号等。

The parts are put into antistatic plastic tubes which are packed in cartons. On the carton ,followings are printed: mark of transportation stipulated in GB191, Company Name , Trade mark , Address , Product Description, Model and Quantity. Sealing mark is stucked on the carton too. Inside the carton there are qualification certificate, stated model , production date and inspector' s code.

● 使用注意事项 (Precautions for use)

1. 该产品为静电敏感元件，要求使用时人和所有的装置(包括烙铁)、设备、机器、桌子、地面等都必须采取防静电措施。

Since the device is static sensitive, it is requested that anti-static measures should be taken on human body, all devices (including soldering iron) and equipment, machinery, desk and ground.

2. 不要对引脚施加不必要的外力。

Do not supply unnecessary stress to lead.

3. 注意保护接收器的接收面，沾污后会影晌接收性能，同时不要触碰接收表面。

Please pay careful attention to the lens of receivers, It might has a chance to miss-function when the lens get dust or dirty. And also please do not touch the lens.



● 可靠性试验要求 (Reliability Test)

表三 (Table 3)

组别 GROUP	试验项目 TEST ITEM	试样 SAMPLE NUMBER	试验条件 TEST CONDITIONS	指标 TECHNICAL DATA	合格 OK. NUM
1	耐焊接热试验 Soldering heat Durability test	16	(260±5)℃, (10±1) S, 浸渍到离器件本体 (2-2.5) mm the distance from the body to merging (2-2.5) mm	恢复 1 小时后, 测试光电参 数符合表二要求 After resuming for 1 hour, test photoelectric parameters in Table 2.	16
2	温度快速变化 Temp. Fast Changing	12	Ta=(-25±3)℃、Tb=(85±2)℃ 暴露时间: 10 分钟 Exposure duration: 10 min. 转移时间: (2-3) 分钟 Transfer duration: 2-3 min. 循环次数: 5 次 Circulation: 5cycles. 恢复 2 小时后, 做循环湿热试验. After resuming for 2 hours, do the experiments of circulating humidity & heat.	恢复 4 小时后, 测试光电参 数符合表二要求. After resuming for 4 hour, test photoelectric parameters in Table 2.	12
	循环湿热 Circulating Humidity & Heat.		(55±2)℃, 2 次 (2 cycles)		
3	电耐久性 Operating Life	25	Vs=5V, Ev=0.5mW/m ² , 1000h	恢复 4 小时后, 测试下列光 电参数: After resuming for 4 hour, test the following parameters : 距离 (distance) : L≥15M 受控角 (angle) : △θ ≥ ±45deg	25
4	高温贮存 High Temp. Storage	16	85±2℃, 1000h	恢复 4 小时后, 测试光电参 数符合表二要求. After resuming for 4 hour, test photoelectric	16

				parameters in Table 2.
--	--	--	--	------------------------

● 特性曲线 (Characteristics Curve) ($T_{amb}=25^{\circ}C$ unless otherwise specified)

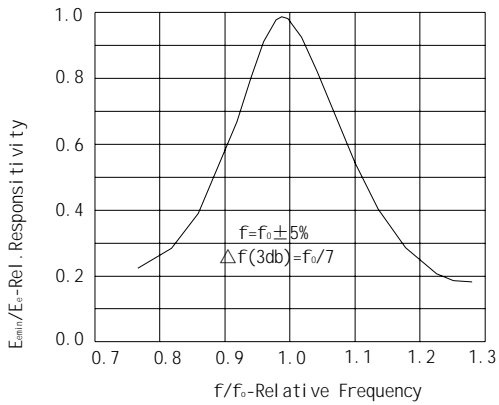

Figure 1. Frequency Dependence of Responsivity

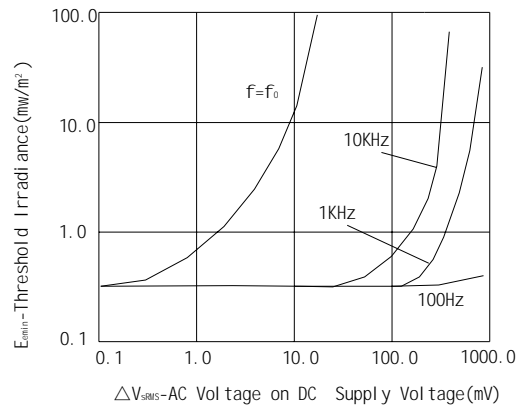

Figure 2. Sensitivity vs. Supply Voltage Disturbances

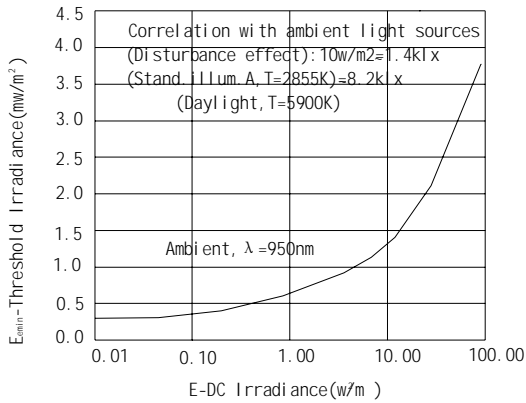

Figure 3. Sensitivity in Bright Ambient

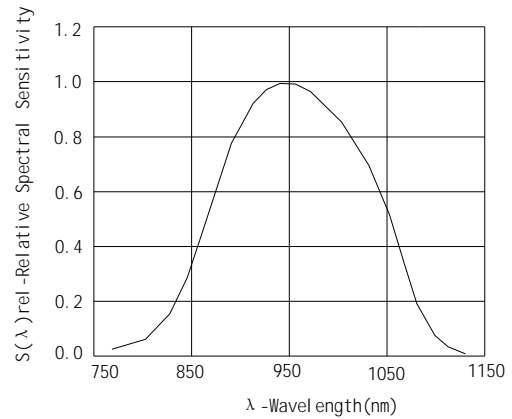

Figure 4. Relative Spectral Sensitivity vs. Wavelength

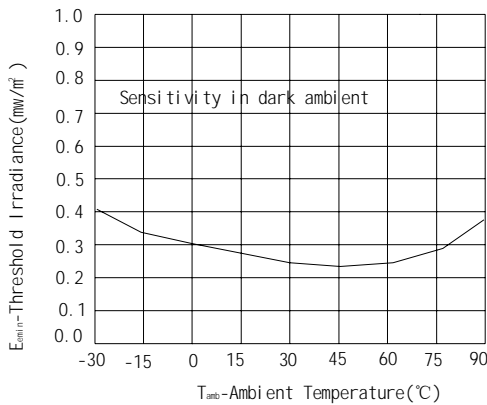

Figure 5. Sensitivity vs. Ambient Temperature

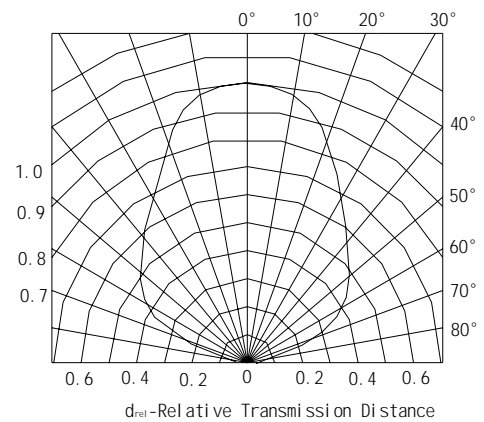
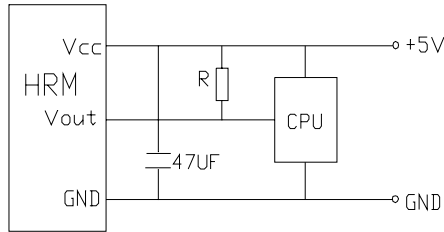

Figure 6. Directivity

● 推荐应用线路 (Recommended circuit)



注: (1)当负载电阻为32.4KΩ时, 推荐外接上拉电阻R在1.6-8.5KΩ。
 (2)当负载电阻改变, R也应作相应调整。
 NOTE: (1)When load is 32.4KΩ, 1.6-8.5KΩ external pull-up resistor(R) is recommended.
 (2) R shall be adjusted with changing of load.

● Block diagram

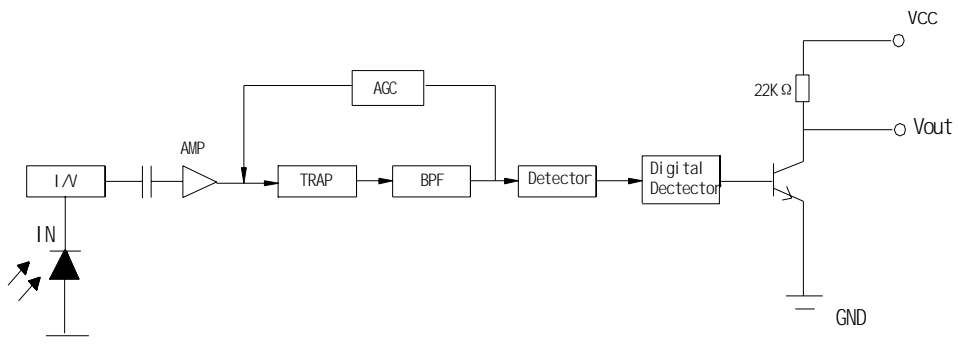

● 外形图 (Outline)

