

Series 77, 10 Bit Digital and Series 78 Analog 360° Phase Shifters & Frequency Translators

Both Series, 77 and 78, comprise a family of eight solid-state PIN diode phase shifters covering the frequency range from 0.5 to 18 GHz in four bands; 0.5 to 2 GHz, 2 to 6 GHz, 4 to 12 GHz and 6 to 18 GHz. All models provide a full 360° range of phase shift and may also be used for frequency translation applications.

Each unit is an integrated assembly of an rf vector modulator and a driver circuit, consisting of a 10-bit D/A converter and a voltage buffer in the Series 77 digital units (see Fig. 1A) and a voltage converter and buffer in the Series 78 analog configuration (see Fig. 1B).

The voltage converter in the Series 78 consists of an A/D converter followed by an 10-bit D/A converter, and converts a continuous analog input voltage into discrete steps of 0.35°.

- 0.5 to 18 GHz in four bands: 0.5 to 2 GHz; 2 to 6 GHz; 4 to 12 GHz; 6 to 18 GHz
- 10 Bit digitally programmable (Series 77)
- Analog control (Series 78)
- High speed
- Guaranteed monotonicity

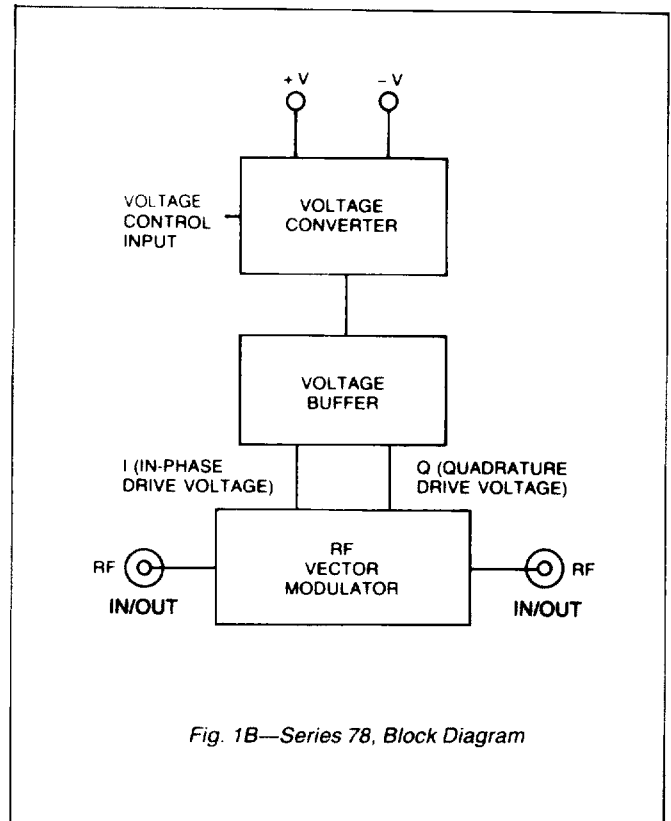
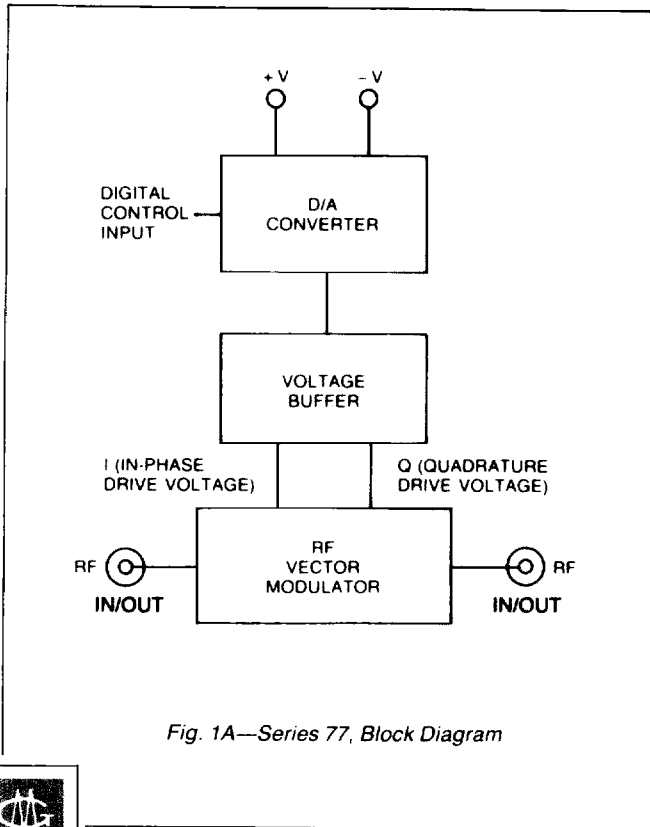
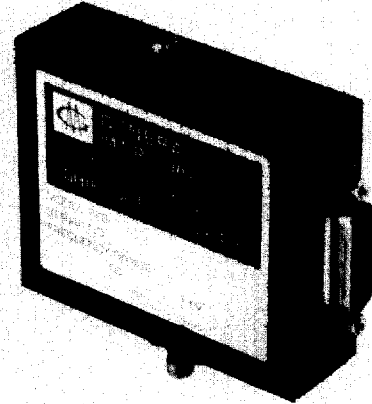

Series 77/78 Specifications

Phase Shift

Phase shift is achieved utilizing the rf vector modulator approach shown in Fig. 2. The 3 dB hybrid coupler divides the rf signal into two quadrature components which are then modulated in proportion to the sine and cosine of the desired phase shift. The signals are then combined in-phase to yield the phase-shifted output.

Excellent phase accuracy and PM/AM performance (see Figs. 4 and 5) are achieved by using linearized double balanced modulators. In their main operating bands, phase accuracy is better than $\pm 10^\circ$ up to 10 GHz and $\pm 12^\circ$ to 18 GHz. This phase accuracy can be extended to cover the band edges by using a built-in frequency correction circuit. Switching speed is better than 500 nsec.

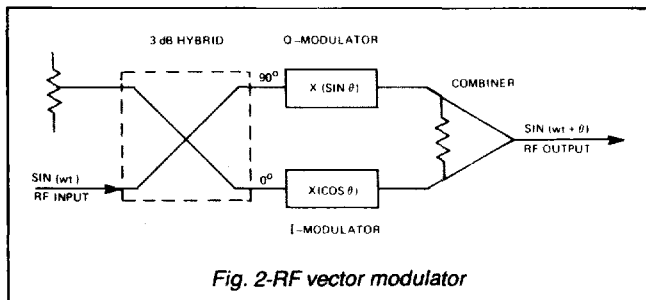

Frequency Translation (Serrodyning)

Special attention in the design of the units has been paid to those characteristics which affect their performance as frequency translators. These include minimizing PM-to-AM conversion, use of high slew rate drivers, and optimizing phase shift linearity with applied signal. As a result, carrier and sideband suppression levels of over 25 and 20 dB, respectively, are obtained in the main bands. The same carrier and sideband performance can be realized over the full stretch band when the internal frequency correction circuit is employed.

See Fig. 3 for input voltage control requirements for Series 77 and 78 when used as a frequency translator.

On special order, frequency translators can be provided for operation over reduced bandwidths with suppression levels of up to 35 dB. Consult the factory for special requirements.

PERFORMANCE CHARACTERISTICS

SERIES 77

Control	10 bit TTL
Logic Input	
Logic "0" (Bit OFF)	-0.3 to +0.8V @ 500 μ A max
Logic "1" (Bit ON)	+2.0 to +5.0V @ 100 μ A max
Power Supply	+5V at 200mA
	+12 to +15V @ 100mA max
	-12 to -15V @ 90mA max

Fig. 3-Series 77 and Series 78 input requirements

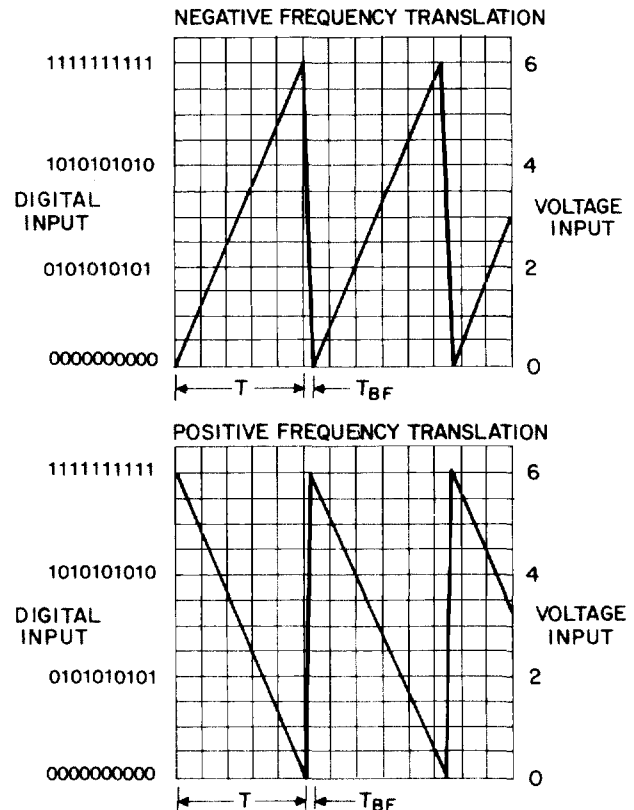

NOTES:

T_{BF} should be less than 1% of T to achieve specified carrier and sideband suppression. Translation Rate = $\frac{1}{T + T_{BF}}$

SERIES 78

Control Voltage	0 to +6V
Sensitivity	23.4 mV/LSB
Resolution	1.41°
Step Uncertainty	0.7° max, 0.3° typ.
Input Resistance	2K ohms
Power Supply	+5V at 300mA
	+12 to +15V at 125mA
	-12 to -15V at 50 mA

COMMON TO BOTH SERIES 77 & 78

Power Handling Capability

Without Performance

Degradation	+20 dBm (+7 dBm for 7720A, 7820)
Survival	+30 dBm
Harmonics	-30 dBc
Phase Variation	0.1°/C



Series 77/78 Specifications

PHASE SHIFTER SPECIFICATIONS

MODEL NOS.	FREQUENCY RANGE (GHz)	INSERTION LOSS (Max.)	VSWR (Max.)	ACCURACY ⁽¹⁾ (Max.)	PM/AM (Max.)
7720A & 7820	Main Band 0.7-1.85 Stretch Band 0.5-2.0	11.5 dB 13.0 dB	1.75	$\pm 10^\circ$ $\pm 15^\circ$	± 1.1 dB ± 2.5 dB
7722A & 7822	Main Band 2.6-5.2 Stretch Band 2.0-6.0	10.0 dB 11.0 dB	1.6	$\pm 10^\circ$ $\pm 15^\circ$	± 1.1 dB ± 1.5 dB
7724A & 7824	Main Band 4.5-10.5 Stretch Band 4.0-12.0	10.5 dB 12.0 dB	1.8	$\pm 10^\circ$ $\pm 15^\circ$	± 1.1 dB ± 2.0 dB
7728A & 7828	Main Band 8.0-18.0 Stretch Band 6.0-18.0	12.0 dB	2.0	$\pm 12^\circ$ $\pm 15^\circ$	± 1.1 dB ± 2.0 dB

OTHER SPECIFICATIONS

Switching Speed (50% TTL to within 10° of Final Phase Value): 500 nsec Max.

Minimum phase shift range:

Series 77: 360° in 1024 Steps (10-bit) Series 78: 360° @ 60° /Volt

FREQUENCY TRANSLATOR SPECIFICATIONS

TRANSLATION RATE (Min.)	CARRIER ⁽¹⁾ SUPPRESSION (Min.)	SIDE BAND ⁽¹⁾ SUPPRESSION (Min.)	INSERTION LOSS VARIATION (Max.) with translation rate:
0 to 500 kHz ⁽²⁾	Main Band: 25 dB Stretch Band: 18 dB	Main Band: 20 dB Stretch Band: 15 dB	200 kHz: 1 dB 500 kHz: 3 dB

NOTES:

- (1) Main band specifications apply if 1 bit TTL logic signal is provided indicating whether input rf signal is in main-band or band-edge.
 (2) All specifications are met using five or more most significant bits for 0 to 200 kHz translation rates. For 201-500 kHz translation rates, only the four most significant bits are used.

TYPICAL PERFORMANCE

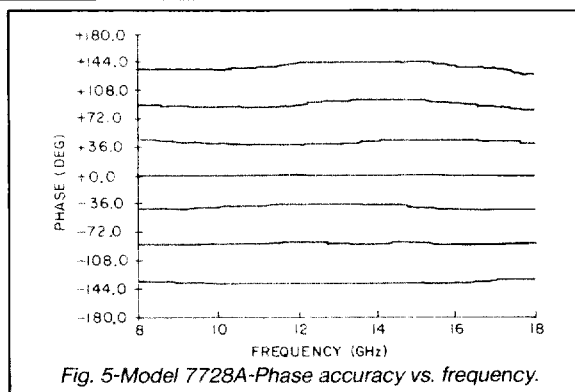
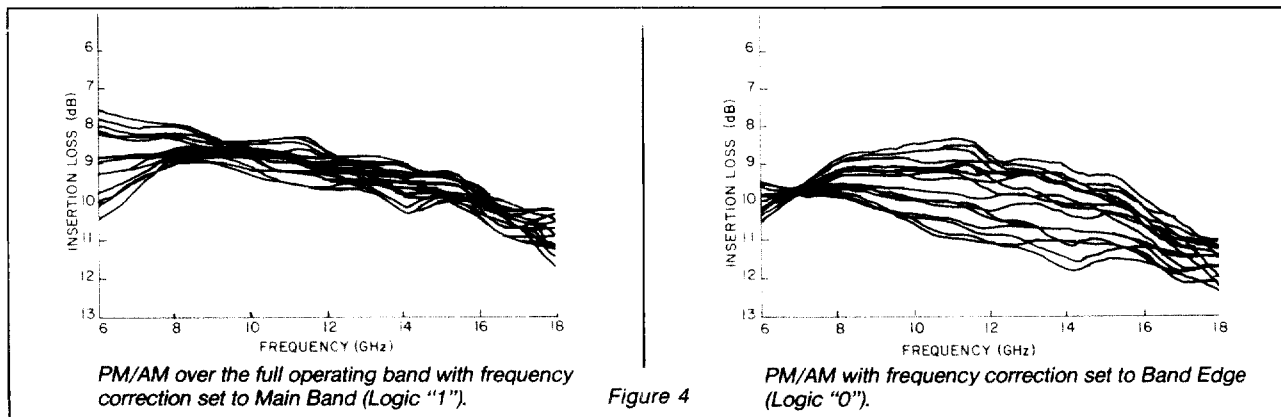

Fig. 5-Model 7728A-Phase accuracy vs. frequency.



Series 77/78 Specifications

ENVIRONMENTAL RATINGS

Operating Temperature Range	-54°C to +100°C
Non-Operating Temperature Range	-65°C to +125°C
Humidity	MIL-STD-202F, Method 103B, Cond. B (96 hrs. at 95%)
Shock	MIL-STD-202F, Method 213B, Cond. B (75G, 6 msec)
Vibration	MIL-STD-202F, Method 204D, Cond. B (.06" double amplitude or 15G, whichever is less)

Altitude	MIL-STD-202F, Method 105C, Cond. B (50,000 ft.)
Temp. Cycling	MIL-STD-202F, Method 107D, Cond. A, 5 cycles

ACCESSORY FURNISHED

Mating power/control connector

AVAILABLE OPTIONS

Option No.	Description
7	Two SMA male rf connectors
10	One SMA male (J2) and one SMA female (J1) rf connector

J3 PIN FUNCTIONS		
Pin No.	Function	
	Series 77 (1)	Series 78
1	-12V to -15V	-12V to -15V
2	+12V to +15V	+12V to +15V
3	Freq. Correction Circuit Select (3) "0" = Bond Edge	Freq. Correction Circuit Select "0" = Bond Edge
4	1.4° (3)	Not Used
5	5.6° (3)	Not Used
6	45.0° (3)	Not Used
7	180.0° (MSB) (3)	Not Used
8	90.0° (3)	Not Used
9	Ground	Ground (Sig)
10	0.7° (3)	Ground (PWR)
11	22.5°	Not Used
12	2.8°	Not Used
13	11.3°	Not Used
14	.035° (LSB)	Control Voltage
15	+5V±0.5VDC (2)	+5V

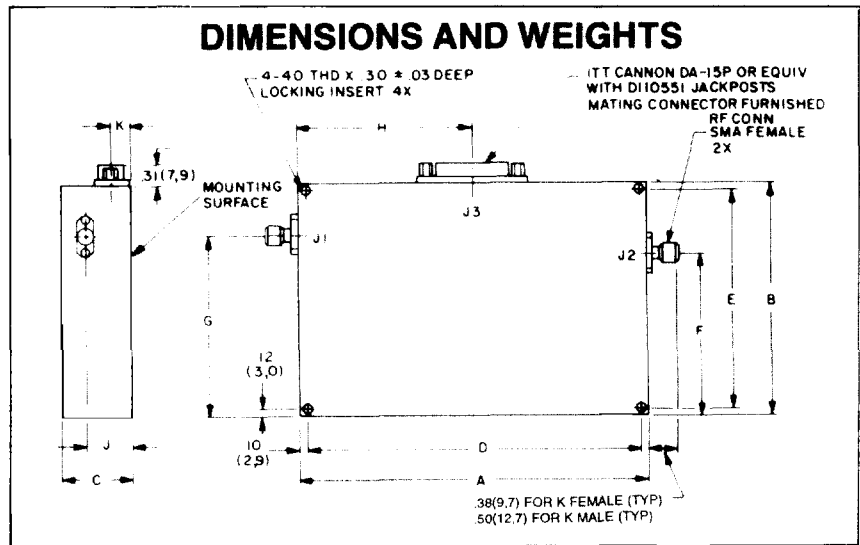

NOTE:

- (1) Unused logic bits must be grounded
- (2) Must not exceed +7VDC. See footnote (3) below
- (3) Must not be greater than +0.3 VDC above voltage at pin 15

MODEL	A	B	C	D	E	F	G	H	J	K	WEIGHT (APPROX)
7720A	4.95 ± .03	3.38 ± .03	1.02 (25.9)	4.75 ± .01	3.12 ± .01	2.62	1.69	2.48	.73 (18.5)	.32 (8.1)	13 oz (369 gm)
7820	(125.7)	(85.9)	1.48 (37.6)	(120.7)	(79.2)	(86.5)	(42.9)	(62.9)	1.18 (30.0)	.78 (19.8)	15 oz (425 gm)
7722A			.84 (21.3)				1.99		.66 (16.8)	.32 (8.1)	9 oz (255 gm)
7822	3.25 ± .03	3.25 ± .03	1.25 (31.8)	3.05 ± .01	3.00 ± .01	1.63	(50.5)	1.63	1.07 (27.2)	.72 (18.3)	10 oz (284 gm)
7724A	(82.6)	(82.6)	.84 (21.3)	(77.5)	(76.2)	(41.4)	1.83	(41.4)	.66 (16.8)	.32 (8.1)	9 oz (255 gm)
7824			1.25 (31.8)				(46.5)		1.07 (27.2)	.72 (18.3)	10 oz (284 gm)
7728A	2.50 ± .03	3.00 ± .03	.88 (22.4)	2.30 ± .01	2.75 ± .01	1.50	1.63	1.25	.71 (18.0)	.39 (9.9)	6 oz (170 gm)
7828	(63.5)	(76.2)	1.18 (30.2)	(58.4)	(69.9)	(38.1)	(41.4)	(31.1)	.72 (18.3)	.69 (17.6)	8 oz (227 gm)

Dimensional tolerances, unless otherwise indicated: .xx ± .02, xxx ± .005

