

Quad, Dual Data Entry, D-Type, Flip-Flop

The 41CG(M) and 41EA(L) devices are bipolar, NPN, sealed junction, silicon integrated circuits. They are available in wire-bonded, 16-pin plastic DIPs. This circuit contains a quad dual-data-entry, D-Type, negative edge-triggered flip-flop with common clock.

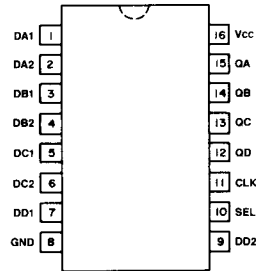

Truth Table

t_n			t_{n+1}
Select	D ₁	D ₂	Q
L	L	X	L
L	H	X	H
H	X	L	L
H	X	H	H

H = High Level
 L = Low Level
 X = Irrelevant

41CG(M), 41EA(L)

Logic Diagram

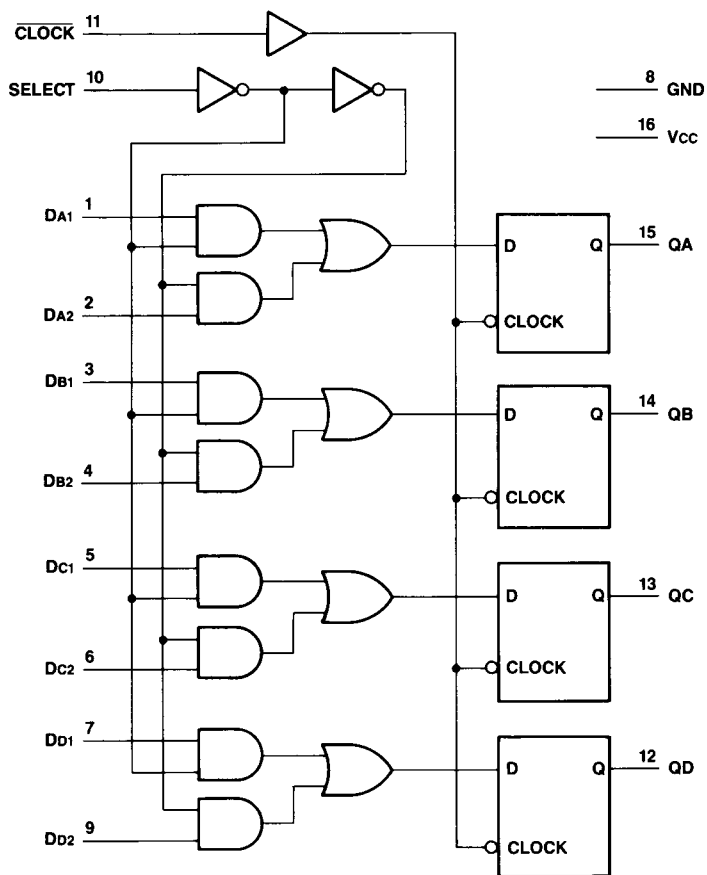

Electrical Characteristics

V_{CC} = 5.0 ±0.5 V, T_J = 0 to 85 °C

Parameter	Symbol	Test Conditions	MTTL Family			LTTL Family			Unit
			41CG Device			41EA Device			
			Min	Typ	Max	Min	Typ	Max	
Output Voltage									
High	V _{OH}	V _{CC} =4.5 V, I _{OH} =-4.0 mA	2.4	3.5	—	—	—	—	V
High	V _{OH}	V _{CC} =4.5 V, I _{OH} =-0.4 mA	—	—	—	2.4	3.5	—	V
Low	V _{OL}	V _{CC} =4.5 V, I _{OL} =9.8 mA	—	0.25	0.4	—	—	—	V
Low	V _{OL}	V _{CC} =4.5 V, I _{OL} =2.4 mA	—	—	—	—	0.25	0.4	V
Input Voltage									
High	V _{IH}	—	1.8	—	—	1.8	—	—	V
Low	V _{IL}	—	—	—	0.8	—	—	0.8	V
Clamp	V _{IK}	I _{IK} = -5 mA	—	—	-1.5	—	—	-1.5	V
Input Current									
High, V _{IH} =2.4 V	I _{IH}	V _{CC} =5.5 V	—	—	40	—	—	10	μA
High, V _{IH} =5.5 V	I _{IH}	V _{CC} =5.5 V	—	—	200	—	—	100	μA
Low	I _{IL}	V _{CC} =5.5 V, V _{IL} =0.4 V	—	—	-1.05	—	—	-0.24	mA
Output Current Short-Circuit	I _{OS}	V _{CC} =5.5 V, V _{OL} =0.0 V	-20	—	-100	-5	—	-30	mA
Power Supply Current	I _{CC}	V _{CC} =5.5 V	—	—	55	—	—	13	mA

Timing Characteristics

V_{CC}=5.0 V, T_J=25 °C

Parameter	MTTL Family			LTTL Family			Unit
	41CG Device			41EA Device			
	Min	Typ	Max	Min	Typ	Max	
Input Clock Frequency (f _θ max)	20	—	—	6	—	—	MHz
Pulse Width Clock (t _{θw})	15	—	—	60	—	—	ns
Propagation Delays							
Clock							
t _{PHL}	—	—	30	—	—	90	ns
t _{PLH}	—	—	25	—	—	80	ns
Set-Up Time							
Data Control							
t _{DS}	5	—	—	10	—	—	ns
Mode Control							
t _{MS}	15	—	—	30	—	—	ns
Hold Time							
Data Control							
t _{DH}	15	—	—	25	—	—	ns
Mode Control							
t _{MH}	15	—	—	40	—	—	ns
Transition Times							
t _{rHL}	—	—	8	—	—	25	ns
t _{rLH}	—	—	15	—	—	160	ns

Maximum Ratings

Power supply voltage (V _{CC})	7.0 V
Input voltage (V _I)	5.5 V
Operating temperature range (T _J)	-25 to +125 °C
Storage temperature range (T _{stg})	-40 to +125 °C

Maximum ratings are defined as the limiting conditions that the user can apply to the device under all variations of circuit and environmental conditions. If any rating is exceeded, permanent damage to the device may result.

Bonding or soldering of the external leads of this device can be performed safely at temperatures up to 300 °C.