

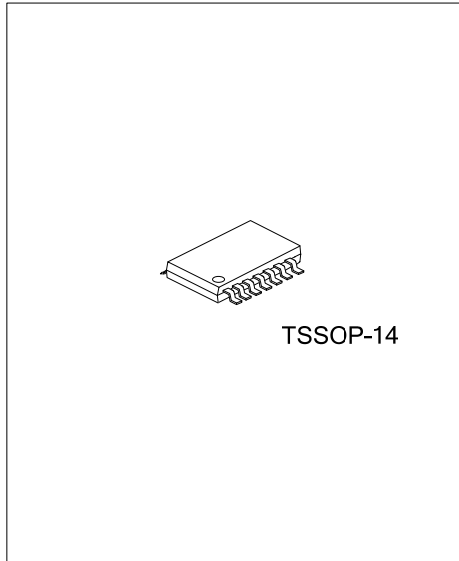

### 4-BIT BIDIRECTIONAL VOLTAGE-LEVEL TRANSLATOR WITH AUTOMATIC DIRECTION SENSING



#### DESCRIPTION

The UTC **UTXB0104** is 4-bit non-inverting translator uses two separate configurable power-supply rails. The A port is designed to track  $V_{CCA}$ .  $V_{CCA}$  accepts any supply voltage from 1.2V to 3.6V. The B port is designed to track  $V_{CCB}$ .  $V_{CCB}$  accepts any supply voltage from State 1.65V to 5.5V. This allows for universal low Voltage bidirectional translation between any of the 1.2V, 1.5V, 1.8V, 2.5V, 3.3V, and 5V voltage nodes.  $V_{CCA}$  should not exceed  $V_{CCB}$ .

When the output-enable (OE) input is low, all outputs are placed in the high-impedance state. To ensure the high-impedance state during power up or power down, OE should be tied to GND through a pull-down resistor; the minimum value of the resistor is determined by the current-sourcing capability of the driver.

The **UTC UTXB0104** is designed so that the OE input circuit is supplied by  $V_{CCA}$ .

This device is fully specified for partial-power-down applications using  $I_{OFF}$  circuitry disables the outputs, preventing damaging current backflow through the device when it is powered down.

#### FEATURES

- \* 1.2V to 3.6V on A Port and 1.65V to 5.5V on B Port ( $V_{CCA} \leq V_{CCB}$ )
- \*  $V_{CC}$  Isolation Feature – If Either  $V_{CC}$  Input Is at GND, All Outputs Are in the High-Impedance State
- \* OE Input Circuit Referenced to  $V_{CCA}$
- \* Low Power Consumption, 5 $\mu$ A Max  $I_{CC}$
- \*  $I_{OFF}$  Supports Partial-Power-Down Mode Operation

#### APPLICATION

- \* Headset
- \* Smartphone
- \* Tablet
- \* Desktop PC

### ■ ORDERING INFORMATION

Ordering Number		Package	Packing
Lead Free	Halogen Free		
UTXB0104L-P14-R	UTXB0104G-P14-R	TSSOP-14	Tape Reel

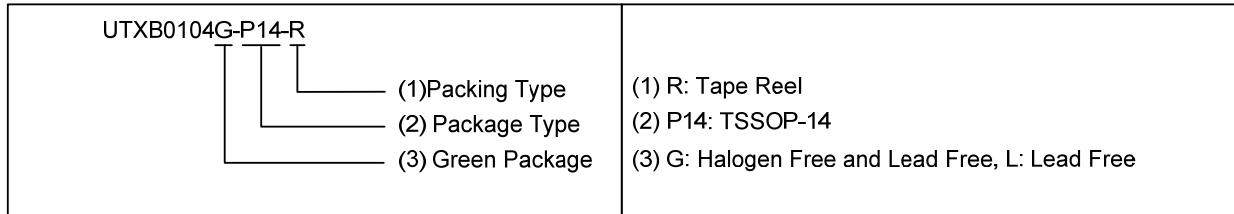

### ■ MARKING

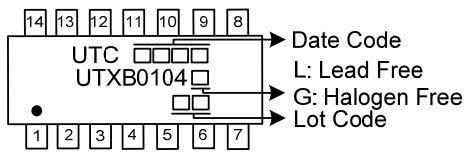

### ■ PIN CONFIGURATION

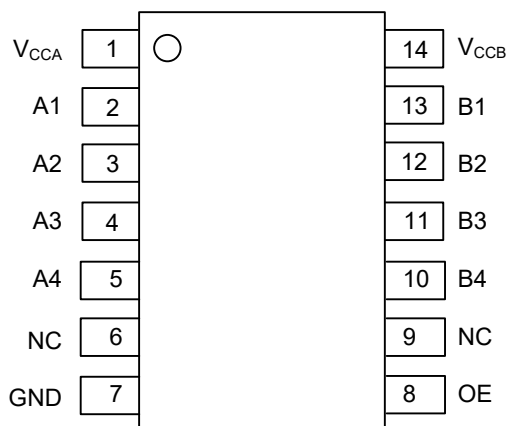

### ■ PIN DESCRIPTION

PIN NO.	PIN NAME	I/O	DESCRIPTION
1	V <sub>CCA</sub>		A-port supply voltage $1.2V \leq V_{CCA} \leq 3.6V$ and $V_{CCA} \leq V_{CCB}$ .
2	A1	I/O	Input/output A1. Referenced to V <sub>CCA</sub>
3	A2	I/O	Input/output A2. Referenced to V <sub>CCA</sub>
4	A3	I/O	Input/output A3. Referenced to V <sub>CCA</sub>
5	A4	I/O	Input/output A4. Referenced to V <sub>CCA</sub>
6	NC		No connection. Not internally connected.
7	GND		Ground
8	OE	I	3-state output-mode enable. Pull OE low to place all outputs in 3-state mode. Referenced to V <sub>CCA</sub>
9	NC		No connection. Not internally connected.
10	B4	I/O	Input/output B4. Referenced to V <sub>CCB</sub>
11	B3	I/O	Input/output B3. Referenced to V <sub>CCB</sub>
12	B2	I/O	Input/output B2. Referenced to V <sub>CCB</sub>
13	B1	I/O	Input/output B1. Referenced to V <sub>CCB</sub>
14	V <sub>CCB</sub>		B-port supply voltage $1.65V \leq V_{CCB} \leq 5.5V$

Note: I=Input, I/O=Input and Output.

### ■ FUNCTION TABLE

SUPPLY VOLTAGE		INPUTS	INPUTS/OUTPUT	
V <sub>CCA</sub>	V <sub>CCB</sub>	OE	A <sub>n</sub>	B <sub>n</sub>
1.2V ~ V <sub>CCB</sub>	1.65V ~ 5.5V	L	Z	Z
1.2V ~ V <sub>CCB</sub>	1.65V ~ 5.5V	H	Input or Output	Output or Input
GND (Note 2)	GND (Note 2)	X	Z	Z

Notes: 1. H = High voltage level ; L = Low voltage level ; Z : High impedance OFF-state ; X = Don't care.

2. When either V<sub>CCA</sub> or V<sub>CCB</sub> is at GND level, the device goes into Power-down mode.

■ BLOCK DIAGRAM

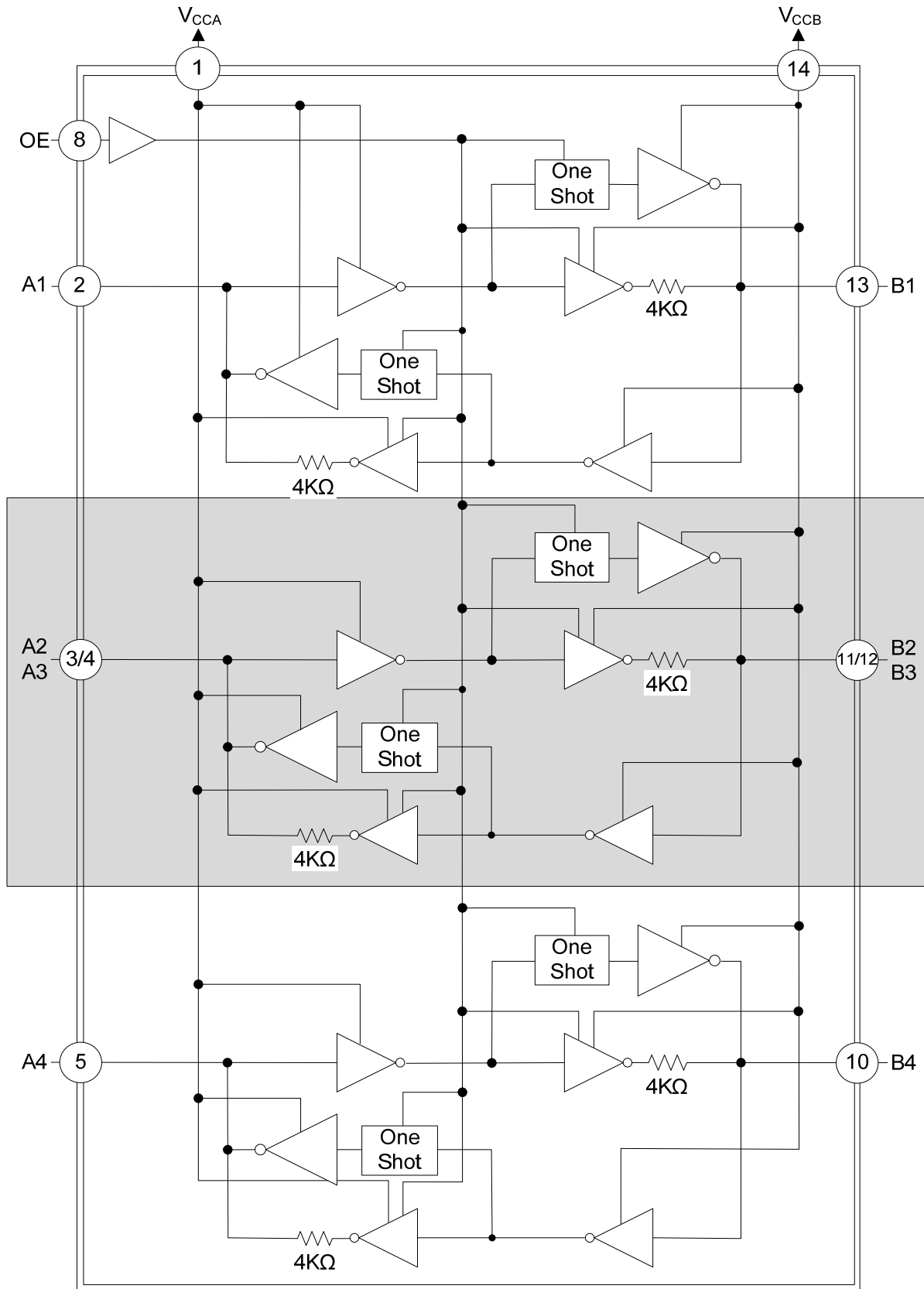

■ ABSOLUTE MAXIMUM RATING (Unless otherwise specified)

PARAMETER		SYMBOL	RATINGS	UNIT
Supply voltage		$V_{CCA}$	-0.5 ~ 4.6	V
Supply voltage		$V_{CCB}$	-0.5 ~ 6.5	V
Input voltage	A Port	$V_{IN}$	-0.5 ~ 4.6	V
	B Port		-0.5 ~ 6.5	V
Voltage range applied to any output in the high-impedance or power-off state	A Port	$V_{OUT}$	-0.5 ~ 4.6	V
	B Port		-0.5 ~ 6.5	V
Voltage range applied to any output in the high or low state	A Port	$V_{OUT}$	-0.5 ~ $V_{CCA}+0.5$	V
	B Port		-0.5 ~ $V_{CCB}+0.5$	V
Input clamp current	$V_{IN}<0$	$I_{IK}$	-50	mA
Output clamp current	$V_{OUT}<0$	$I_{OK}$	-50	mA
Continuous Output Current		$I_{OUT}$	±50	mA
Continuous current through $V_{CCA}$ , $V_{CCB}$ , or GND		$I_{CC}/I_{GND}$	±100	mA
Storage Temperature		$T_{STG}$	-65 ~ +150	°C

Note: Absolute maximum ratings are those values beyond which the device could be permanently damaged. Absolute maximum ratings are stress ratings only and functional device operation is not implied.

■ RECOMMENDED OPERATING CONDITIONS (Unless otherwise specified)

PARAMETER		SYMBOL	TEST CONDITIONS	MIN	TYP	MAX	UNIT
Supply Voltage		$V_{CCA}$		1.2		3.6	V
Supply Voltage		$V_{CCB}$		1.65		5.5	V
Input Voltage		$V_{IN}$		0		$V_{CCI}$	V
Output Voltage	A Port	$V_{OUT}$	$V_{CCA}=1.2V\sim 3.6V$ , $V_{CCB}=1.65V\sim 5.5V$	0		3.6	V
	B Port		$V_{CCA}=1.2V\sim 3.6V$ , $V_{CCB}=1.65V\sim 5.5V$	0		5.5	V
High-Level Input Voltage	Data Inputs	$V_{IH}$	$V_{CCA}=1.2V\sim 3.6V$ , $V_{CCB}=1.65V\sim 5.5V$	$V_{CCI}$ ×0.65 (Note 3)		$V_{CCI}$	V
	OE			$V_{CCA}$ ×0.65		5.5	V
Low-Level Input Voltage	Data Inputs	$V_{IL}$	$V_{CCA}=1.2V\sim 3.6V$ , $V_{CCB}=1.65V\sim 5.5V$	0		$V_{CCI}$ ×0.35 (Note 3)	V
	OE			0		$V_{CCA}$ ×0.35	V
Input Transition Rise or Fall Rate	A Port Inputs	$\Delta t/\Delta v$	$V_{CCA}=1.2V\sim 3.6V$	$V_{CCB}=1.65V\sim 5.5V$		40	ns/V
	B Port Inputs			$V_{CCB}=1.65V\sim 3.6V$		40	ns/V
				$V_{CCB}=4.5V\sim 5.5V$		30	ns/V
Operating Temperature		$T_A$		-40		+125	°C

Notes: 1. The A and B sides of an unused data I/O pair must be held in the same state, i.e., both at  $V_{CCI}$  or both at GND.

2.  $V_{CCA}$  must be less than or equal to  $V_{CCB}$  and must not exceed 3.6V.

3.  $V_{CCI}$  is the supply voltage associated with the input port.

■ ELECTRICAL CHARACTERISTICS (Unless otherwise specified)

PARAMETER		SYMBOL	TEST CONDITIONS	MIN	TYP	MAX	UNIT
Port A Output High Voltage		$V_{OHA}$	$V_{CCA}=1.2V, I_{OH}=-20\mu A$		1.1		V
			$V_{CCB}=1.4V\sim 3.6V, I_{OH}=-20\mu A$	$V_{CCA}$ -0.4			V
Port A Output Low Voltage		$V_{OLA}$	$V_{CCA}=1.2V, I_{OL}=20\mu A$		0.3		V
			$V_{CCB}=1.4V\sim 3.6V, I_{OL}=20\mu A$			0.4	V
Port B Output High Voltage		$V_{OHB}$	$V_{CCB}=1.65V\sim 5.5V, I_{OH}=-20\mu A$	$V_{CCB}$ -0.4			V
Port B Output Low Voltage		$V_{OLB}$	$V_{CCB}=1.65V\sim 5.5V, I_{OL}=20\mu A$			0.4	V
Input Leakage Current	OE	$I_{I(LEAK)}$	$V_I=V_{CCI}$ or GND, $V_{CCA}=1.2V\sim 3.6V,$ $V_{CCB}=1.65V\sim 5.5V$			$\pm 1$	$\mu A$
Power OFF Leakage Current	A Port	$I_{OFF}$	$V_I$ or $V_{OUT}=0\sim 3.6V, V_{CCA}=0V,$ $V_{CCB}=0V\sim 5.5V$			$\pm 1$	$\mu A$
	B Port		$V_I$ or $V_{OUT}=0\sim 5.5V,$ $V_{CCA}=0V\sim 3.6V, V_{CCB}=0V$			$\pm 1$	$\mu A$
High-Impedance State Output Current	A or B Port	$I_{OZ}$	$V_{CCA}=1.2V\sim 3.6V,$ $V_{CCB}=1.65V\sim 5.5V, OE=GND$			$\pm 1$	$\mu A$
Quiescent Supply Current		$I_{CCA}$	$V_I=V_{CCI}$ or GND $I_O=0A$	$V_{CCA}=1.2V,$ $V_{CCB}=1.65V\sim 5.5V$		0.06	$\mu A$
				$V_{CCA}=1.4V\sim 3.6V,$ $V_{CCB}=1.65V\sim 5.5V$		5	$\mu A$
				$V_{CCA}=3.6V, V_{CCB}=0V$		2	$\mu A$
				$V_{CCA}=0V, V_{CCB}=5.5V$		-2	$\mu A$
		$I_{CCB}$		$V_{CCA}=1.2V,$ $V_{CCB}=1.65V\sim 5.5V$		3.4	$\mu A$
				$V_{CCA}=1.4V\sim 3.6V,$ $V_{CCB}=1.65V\sim 5.5V$		5	$\mu A$
				$V_{CCA}=3.6V, V_{CCB}=0V$		-2	$\mu A$
				$V_{CCA}=0V, V_{CCB}=5.5V$		2	$\mu A$
		$I_{CCA}+I_{CCB}$		$V_{CCA}=1.2V,$ $V_{CCB}=1.65V\sim 5.5V$		3.5	$\mu A$
				$V_{CCA}=1.4V\sim 3.6V,$ $V_{CCB}=1.65V\sim 5.5V$		10	$\mu A$
		$I_{CCZA}$		$V_{CCA}=1.2V,$ $V_{CCB}=1.65V\sim 5.5V$ OE=GND		0.05	$\mu A$
				$V_{CCA}=1.4V\sim 3.6V,$ $V_{CCB}=1.65V\sim 5.5V$ OE=GND		5	$\mu A$
$V_{CCA}=1.2V,$ $V_{CCB}=1.65V\sim 5.5V$ OE=GND			3.3	$\mu A$			
$V_{CCA}=1.4V\sim 3.6V,$ $V_{CCB}=1.65V\sim 5.5V$ OE=GND			5	$\mu A$			
Input Capacitance	OE	$C_{IN}$		3		pF	
Output Capacitance	A Port	$C_{IO}$	$V_{CCA}=1.2V\sim 3.6V,$ $V_{CCB}=1.65V\sim 5.5V$		5		pF
	B Port				11		pF

- Notes: 1.  $V_{CCI}$  is the supply voltage associated with the input port.  
 2.  $V_{CCO}$  is the supply voltage associated with the output port.  
 3.  $V_{CCA}$  must be less than or equal to  $V_{CCB}$ , and  $V_{CCA}$  must not exceed 3.6V.

■ SWITCHING CHARACTERISTICS (Unless otherwise specified)

PARAMETER	SYMBOL	TEST CONDITIONS	MIN	TYP	MAX	UNIT			
Propagation Delay From Input (A) to Output (B)	t <sub>PD</sub>	V <sub>CCA</sub> =1.2V	V <sub>CCB</sub> =1.8V		8.9	ns			
			V <sub>CCB</sub> =2.5V		7.7	ns			
			V <sub>CCB</sub> =3.3V		7.3	ns			
			V <sub>CCB</sub> =5V		7.5	ns			
		V <sub>CCA</sub> =1.5V±0.1V	V <sub>CCB</sub> =1.8V±0.15V	1.4		14.4	ns		
			V <sub>CCB</sub> =2.5V±0.2V	1.2		11.6	ns		
			V <sub>CCB</sub> =3.3V±0.3V	1.1		11.5	ns		
			V <sub>CCB</sub> =5V±0.5V	0.8		11.4	ns		
		V <sub>CCA</sub> =1.8V±0.15V	V <sub>CCB</sub> =1.8V±0.15V	1.6		12	ns		
			V <sub>CCB</sub> =2.5V±0.2V	1.4		8.7	ns		
			V <sub>CCB</sub> =3.3V±0.3V	1.3		7.8	ns		
			V <sub>CCB</sub> =5V±0.5V	1.2		7.5	ns		
		V <sub>CCA</sub> =2.5V±0.2V	V <sub>CCB</sub> =2.5V±0.2V	1.1		7	ns		
			V <sub>CCB</sub> =3.3V±0.3V	1.0		5.9	ns		
			V <sub>CCB</sub> =5V±0.5V	0.9		5.4	ns		
		V <sub>CCA</sub> =3.3V±0.3V	V <sub>CCB</sub> =3.3V±0.3V	0.9		5.2	ns		
			V <sub>CCB</sub> =5V±0.5V	0.8		4.5	ns		
		Propagation Delay From Input (B) to Output (A)	t <sub>PD</sub>	V <sub>CCA</sub> =1.2V	V <sub>CCB</sub> =1.8V		9.4	ns	
					V <sub>CCB</sub> =2.5V		8.4	ns	
					V <sub>CCB</sub> =3.3V		8.0	ns	
					V <sub>CCB</sub> =5V		8.8	ns	
				V <sub>CCA</sub> =1.5V±0.1V	V <sub>CCB</sub> =1.8V±0.15V	1.4		15.7	ns
					V <sub>CCB</sub> =2.5V±0.2V	1.2		13.5	ns
					V <sub>CCB</sub> =3.3V±0.3V	1.1		13.2	ns
V <sub>CCB</sub> =5V±0.5V	0.8					15.2	ns		
V <sub>CCA</sub> =1.8V±0.15V	V <sub>CCB</sub> =1.8V±0.15V			1.6		13	ns		
	V <sub>CCB</sub> =2.5V±0.2V			1.4		9.4	ns		
	V <sub>CCB</sub> =3.3V±0.3V			1.3		8.6	ns		
	V <sub>CCB</sub> =5V±0.5V			1.2		8.1	ns		
V <sub>CCA</sub> =2.5V±0.2V	V <sub>CCB</sub> =2.5V±0.2V			1.1		7.3	ns		
	V <sub>CCB</sub> =3.3V±0.3V			1.0		5.8	ns		
	V <sub>CCB</sub> =5V±0.5V			0.9		5.1	ns		
V <sub>CCA</sub> =3.3V±0.3V	V <sub>CCB</sub> =3.3V±0.3V			1.0		5.4	ns		
	V <sub>CCB</sub> =5V±0.5V			0.9		4.3	ns		
Enable Time From Input (OE) to Output (A or B)	t <sub>en</sub>			V <sub>CCA</sub> =1.2V	V <sub>CCB</sub> =1.8V		1	μs	
					V <sub>CCB</sub> =2.5V		1	μs	
					V <sub>CCB</sub> =3.3V		1	μs	
					V <sub>CCB</sub> =5V		1	μs	
				V <sub>CCA</sub> =1.5V±0.1V	V <sub>CCB</sub> =1.8V±0.15V			1	μs
					V <sub>CCB</sub> =2.5V±0.2V			1	μs
					V <sub>CCB</sub> =3.3V±0.3V			1	μs
		V <sub>CCB</sub> =5V±0.5V				1	μs		
		V <sub>CCA</sub> =1.8V±0.15V	V <sub>CCB</sub> =1.8V±0.15V			1	μs		
			V <sub>CCB</sub> =2.5V±0.2V			1	μs		
			V <sub>CCB</sub> =3.3V±0.3V			1	μs		
			V <sub>CCB</sub> =5V±0.5V			1	μs		
		V <sub>CCA</sub> =2.5V±0.2V	V <sub>CCB</sub> =2.5V±0.2V			1	μs		
			V <sub>CCB</sub> =3.3V±0.3V			1	μs		
			V <sub>CCB</sub> =5V±0.5V			1	μs		
		V <sub>CCA</sub> =3.3V±0.3V	V <sub>CCB</sub> =3.3V±0.3V			1	μs		
			V <sub>CCB</sub> =5V±0.5V			1	μs		

■ SWITCHING CHARACTERISTICS (Cont.)

PARAMETER		SYMBOL	TEST CONDITIONS	MIN	TYP	MAX	UNIT				
Disable Time From Input (OE) to Output (A)		$t_{dis}$	$V_{CCA}=1.2V$	$V_{CCB}=1.8V$		18	ns				
				$V_{CCB}=2.5V$		15	ns				
				$V_{CCB}=3.3V$		14	ns				
				$V_{CCB}=5V$		14	ns				
			$V_{CCA}=1.5V\pm 0.1V$	$V_{CCB}=1.8V\pm 0.15V$	5.9		31	ns			
				$V_{CCB}=2.5V\pm 0.2V$	5.7		25.9	ns			
				$V_{CCB}=3.3V\pm 0.3V$	5.6		23	ns			
				$V_{CCB}=5V\pm 0.5V$	5.7		22.4	ns			
			$V_{CCA}=1.8V\pm 0.15V$	$V_{CCB}=1.8V\pm 0.15V$	5.9		31	ns			
				$V_{CCB}=2.5V\pm 0.2V$	5.1		21.3	ns			
				$V_{CCB}=3.3V\pm 0.3V$	5.0		19.3	ns			
				$V_{CCB}=5V\pm 0.5V$	5.0		17.4	ns			
			$V_{CCA}=2.5V\pm 0.2V$	$V_{CCB}=2.5V\pm 0.2V$	5.1		21.3	ns			
				$V_{CCB}=3.3V\pm 0.3V$	4.6		15.2	ns			
				$V_{CCB}=5V\pm 0.5V$	4.6		13.2	ns			
			$V_{CCA}=3.3V\pm 0.3V$	$V_{CCB}=3.3V\pm 0.3V$	4.6		15.2	ns			
				$V_{CCB}=5V\pm 0.5V$	4.3		12.1	ns			
			Disable Time From Input (OE) to Output (B)		$t_{dis}$	$V_{CCA}=1.2V$	$V_{CCB}=1.8V$		20	ns	
							$V_{CCB}=2.5V$		17	ns	
							$V_{CCB}=3.3V$		16	ns	
							$V_{CCB}=5V$		16	ns	
						$V_{CCA}=1.5V\pm 0.1V$	$V_{CCB}=1.8V\pm 0.15V$	5.4		30.3	ns
							$V_{CCB}=2.5V\pm 0.2V$	4.9		22.8	ns
							$V_{CCB}=3.3V\pm 0.3V$	4.8		20	ns
$V_{CCB}=5V\pm 0.5V$	4.9						19.5	ns			
$V_{CCA}=1.8V\pm 0.15V$	$V_{CCB}=1.8V\pm 0.15V$	5.4					30.3	ns			
	$V_{CCB}=2.5V\pm 0.2V$	4.4					20.8	ns			
	$V_{CCB}=3.3V\pm 0.3V$	4.2					17.9	ns			
	$V_{CCB}=5V\pm 0.5V$	4.3					16.3	ns			
$V_{CCA}=2.5V\pm 0.2V$	$V_{CCB}=2.5V\pm 0.2V$	4.4					20.8	ns			
	$V_{CCB}=3.3V\pm 0.3V$	3.8					16	ns			
	$V_{CCB}=5V\pm 0.5V$	3.9					13.9	ns			
$V_{CCA}=3.3V\pm 0.3V$	$V_{CCB}=3.3V\pm 0.3V$	3.8					16	ns			
	$V_{CCB}=5V\pm 0.5V$	3.4					13.2	ns			
Rise and Fall Time A Port Rise And Fall Times		$t_{rA}, t_{fA}$				$V_{CCA}=1.2V$	$V_{CCB}=1.8V$		4.2	ns	
							$V_{CCB}=2.5V$		4.2	ns	
							$V_{CCB}=3.3V$		4.2	ns	
							$V_{CCB}=5V$		4.2	ns	
						$V_{CCA}=1.5V\pm 0.1V$	$V_{CCB}=1.8V\pm 0.15V$	1.4		5.1	ns
							$V_{CCB}=2.5V\pm 0.2V$	1.4		5.1	ns
							$V_{CCB}=3.3V\pm 0.3V$	1.4		5.1	ns
			$V_{CCB}=5V\pm 0.5V$	1.4			5.1	ns			
			$V_{CCA}=1.8V\pm 0.15V$	$V_{CCB}=1.8V\pm 0.15V$	1.0		4.2	ns			
				$V_{CCB}=2.5V\pm 0.2V$	1.1		4.1	ns			
				$V_{CCB}=3.3V\pm 0.3V$	1.1		4.1	ns			
				$V_{CCB}=5V\pm 0.5V$	1.1		4.1	ns			
			$V_{CCA}=2.5V\pm 0.2V$	$V_{CCB}=2.5V\pm 0.2V$	0.8		3.0	ns			
				$V_{CCB}=3.3V\pm 0.3V$	0.8		3.0	ns			
				$V_{CCB}=5V\pm 0.5V$	0.8		3.0	ns			
			$V_{CCA}=3.3V\pm 0.3V$	$V_{CCB}=3.3V\pm 0.3V$	0.7		2.5	ns			
				$V_{CCB}=5V\pm 0.5V$	0.7		2.5	ns			

■ SWITCHING CHARACTERISTICS (Cont.)

PARAMETER		SYMBOL	TEST CONDITIONS	MIN	TYP	MAX	UNIT	
Rise and Fall Time	B Port Rise And Fall Times	$t_{rB}, t_{fB}$	$V_{CCA}=1.2V$	$V_{CCB}=1.8V$		2.1	ns	
				$V_{CCB}=2.5V$		1.5	ns	
				$V_{CCB}=3.3V$		1.2	ns	
				$V_{CCB}=5V$		1.1	ns	
			$V_{CCA}=1.5V\pm 0.1V$	$V_{CCB}=1.8V\pm 0.15V$	0.9		4.5	ns
				$V_{CCB}=2.5V\pm 0.2V$	0.6		3.2	ns
				$V_{CCB}=3.3V\pm 0.3V$	0.5		2.8	ns
				$V_{CCB}=5V\pm 0.5V$	0.4		2.7	ns
			$V_{CCA}=1.8V\pm 0.15V$	$V_{CCB}=1.8V\pm 0.15V$	0.9		3.8	ns
				$V_{CCB}=2.5V\pm 0.2V$	0.6		3.2	ns
				$V_{CCB}=3.3V\pm 0.3V$	0.5		2.8	ns
				$V_{CCB}=5V\pm 0.5V$	0.4		2.7	ns
			$V_{CCA}=2.5V\pm 0.2V$	$V_{CCB}=2.5V\pm 0.2V$	0.7		2.6	ns
				$V_{CCB}=3.3V\pm 0.3V$	0.5		2.8	ns
			$V_{CCA}=3.3V\pm 0.3V$	$V_{CCB}=3.3V\pm 0.3V$	0.5		2.1	ns
				$V_{CCB}=5V\pm 0.5V$	0.4		2.7	ns
Data Rate		$f_{data}$	$V_{CCA}=1.2V, V_{CCB}=1.8V\sim 5V$		20		Mbps	
			$V_{CCA}=1.5V\pm 0.1V, V_{CCB}=1.65V\sim 5.5V$			40	Mbps	
			$V_{CCA}=1.8V\pm 0.15V, V_{CCB}=1.65V\sim 5.5V$			60	Mbps	
			$V_{CCA}=2.5V\pm 0.2V, V_{CCB}=2.3V\sim 5.5V$			100	Mbps	
			$V_{CCA}=3.3V\pm 0.3V, V_{CCB}=3.0V\sim 5.5V$			100	Mbps	
Pulse Duration	Data Inputs	$t_w$	$V_{CCA}=1.2V, V_{CCB}=1.8V\sim 5V$		50		ns	
			$V_{CCA}=1.5V\pm 0.1V, V_{CCB}=1.65V\sim 5.5V$	25			ns	
			$V_{CCA}=1.8V\pm 0.15V, V_{CCB}=1.65V\sim 5.5V$	17			ns	
			$V_{CCA}=2.5V\pm 0.2V, V_{CCB}=2.3V\sim 5.5V$	10			ns	
			$V_{CCA}=3.3V\pm 0.3V, V_{CCB}=3.0V\sim 5.5V$	10			ns	

■ OPERATING CHARACTERISTICS (Unless otherwise specified)

PARAMETER		SYMBOL	TEST CONDITIONS	MIN	TYP	MAX	UNIT					
Power Dissipation Capacitance	A Port Input B Port Output	C <sub>PDA</sub>	V <sub>CCA</sub> =1.2V V <sub>CCB</sub> =5V		7.8		pF					
			V <sub>CCA</sub> =1.2V V <sub>CCB</sub> =1.8V		10		pF					
			V <sub>CCA</sub> =1.5V V <sub>CCB</sub> =1.8V		9		pF					
			V <sub>CCA</sub> =1.8V V <sub>CCB</sub> =1.8V		8		pF					
			V <sub>CCA</sub> =2.5V V <sub>CCB</sub> =2.5V		8		pF					
			V <sub>CCA</sub> =2.5V V <sub>CCB</sub> =5V		8		pF					
	B Port Input A Port Output		C <sub>PDA</sub>	C <sub>L</sub> =0, f=10MHz t <sub>r</sub> =t <sub>f</sub> =1nS OE=V <sub>CCA</sub> (Output Enabled)	V <sub>CCA</sub> =3.3V V <sub>CCB</sub> =3.3~5V		9		pF			
					V <sub>CCA</sub> =1.2V V <sub>CCB</sub> =5V		12		pF			
					V <sub>CCA</sub> =1.2V V <sub>CCB</sub> =1.8V		11		pF			
					V <sub>CCA</sub> =1.5V V <sub>CCB</sub> =1.8V		11		pF			
					V <sub>CCA</sub> =1.8V V <sub>CCB</sub> =1.8V		11		pF			
					V <sub>CCA</sub> =2.5V V <sub>CCB</sub> =2.5V		11		pF			
					V <sub>CCA</sub> =2.5V V <sub>CCB</sub> =5V		11		pF			
					V <sub>CCA</sub> =3.3V V <sub>CCB</sub> =3.3~5V		11		pF			
					A Port Input B Port Output	C <sub>PDA</sub>	C <sub>L</sub> =0, f=10MHz t <sub>r</sub> =t <sub>f</sub> =1nS OE=GND (Output Disabled)	V <sub>CCA</sub> =1.2V V <sub>CCB</sub> =5V		0.01		pF
								V <sub>CCA</sub> =1.2V V <sub>CCB</sub> =1.8V		0.01		pF
								V <sub>CCA</sub> =1.5V V <sub>CCB</sub> =1.8V		0.01		pF
								V <sub>CCA</sub> =1.8V V <sub>CCB</sub> =1.8V		0.01		pF
	V <sub>CCA</sub> =2.5V V <sub>CCB</sub> =2.5V			0.01					pF			
	V <sub>CCA</sub> =2.5V V <sub>CCB</sub> =5V			0.01					pF			
	V <sub>CCA</sub> =3.3V V <sub>CCB</sub> =3.3~5V			0.01					pF			

■ OPERATING CHARACTERISTICS (Cont.)

PARAMETER		SYMBOL	TEST CONDITIONS	MIN	TYP	MAX	UNIT
Power Dissipation Capacitance	B Port Input A Port Output	C <sub>PDA</sub>	V <sub>CCA</sub> =1.2V V <sub>CCB</sub> =5V		0.01		pF
			V <sub>CCA</sub> =1.2V V <sub>CCB</sub> =1.8V		0.01		pF
			V <sub>CCA</sub> =1.5V V <sub>CCB</sub> =1.8V		0.01		pF
			V <sub>CCA</sub> =1.8V V <sub>CCB</sub> =1.8V		0.01		pF
			V <sub>CCA</sub> =2.5V V <sub>CCB</sub> =2.5V		0.01		pF
			V <sub>CCA</sub> =2.5V V <sub>CCB</sub> =5V		0.01		pF
			V <sub>CCA</sub> =3.3V V <sub>CCB</sub> =3.3~5V		0.01		pF
			A Port Input B Port Output	C <sub>PDB</sub>	V <sub>CCA</sub> =1.2V V <sub>CCB</sub> =5V		38.1
	V <sub>CCA</sub> =1.2V V <sub>CCB</sub> =1.8V				28		pF
	V <sub>CCA</sub> =1.5V V <sub>CCB</sub> =1.8V				28		pF
	V <sub>CCA</sub> =1.8V V <sub>CCB</sub> =1.8V				28		pF
	V <sub>CCA</sub> =2.5V V <sub>CCB</sub> =2.5V				29		pF
	V <sub>CCA</sub> =2.5V V <sub>CCB</sub> =5V				29		pF
	V <sub>CCA</sub> =3.3V V <sub>CCB</sub> =3.3~5V				29		pF
	B Port Input A Port Output	C <sub>PDB</sub>			V <sub>CCA</sub> =1.2V V <sub>CCB</sub> =5V		25.4
			V <sub>CCA</sub> =1.2V V <sub>CCB</sub> =1.8V		19		pF
			V <sub>CCA</sub> =1.5V V <sub>CCB</sub> =1.8V		18		pF
			V <sub>CCA</sub> =1.8V V <sub>CCB</sub> =1.8V		18		pF
			V <sub>CCA</sub> =2.5V V <sub>CCB</sub> =2.5V		19		pF
			V <sub>CCA</sub> =2.5V V <sub>CCB</sub> =5V		21		pF
			V <sub>CCA</sub> =3.3V V <sub>CCB</sub> =3.3~5V		22		pF

■ OPERATING CHARACTERISTICS (Cont.)

PARAMETER		SYMBOL	TEST CONDITIONS	MIN	TYP	MAX	UNIT	
Power Dissipation Capacitance	A Port Input B Port Output	C <sub>PDB</sub>	V <sub>CCA</sub> =1.2V V <sub>CCB</sub> =5V		0.01		pF	
			V <sub>CCA</sub> =1.2V V <sub>CCB</sub> =1.8V		0.01		pF	
			V <sub>CCA</sub> =1.5V V <sub>CCB</sub> =1.8V		0.01		pF	
			V <sub>CCA</sub> =1.8V V <sub>CCB</sub> =1.8V		0.01		pF	
			V <sub>CCA</sub> =2.5V V <sub>CCB</sub> =2.5V		0.01		pF	
			V <sub>CCA</sub> =2.5V V <sub>CCB</sub> =5V		0.01		pF	
	B Port Input A Port Output		C <sub>L</sub> =0, f=10MHz t <sub>r</sub> =t <sub>f</sub> =1nS OE=GND (Output Disabled)	V <sub>CCA</sub> =3.3V V <sub>CCB</sub> =3.3~5V		0.03		pF
			V <sub>CCA</sub> =1.2V V <sub>CCB</sub> =5V		0.01		pF	
			V <sub>CCA</sub> =1.2V V <sub>CCB</sub> =1.8V		0.01		pF	
			V <sub>CCA</sub> =1.5V V <sub>CCB</sub> =1.8V		0.01		pF	
			V <sub>CCA</sub> =1.8V V <sub>CCB</sub> =1.8V		0.01		pF	
			V <sub>CCA</sub> =2.5V V <sub>CCB</sub> =2.5V		0.01		pF	
			V <sub>CCA</sub> =2.5V V <sub>CCB</sub> =5V		0.01		pF	
			V <sub>CCA</sub> =3.3V V <sub>CCB</sub> =3.3~5V		0.04		pF	

TEST CIRCUIT AND WAVEFORMS

Load Circuit

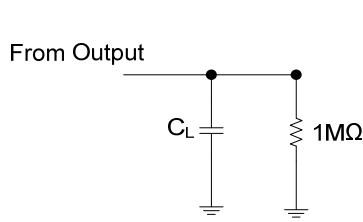

MAX DATA RATE, PULSE DURATION PROPAGATION DELAY OUTPUT RISE AND FALL TIME MEASUREMENT

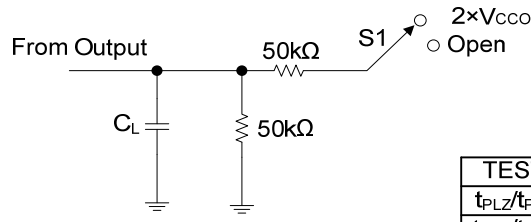

ENABLE/DISABLE TIME MEASUREMENT

TEST	S1
$t_{PLZ}/t_{PZL}$	$2 \times V_{CCO}$
$t_{PHZ}/t_{PZH}$	Open

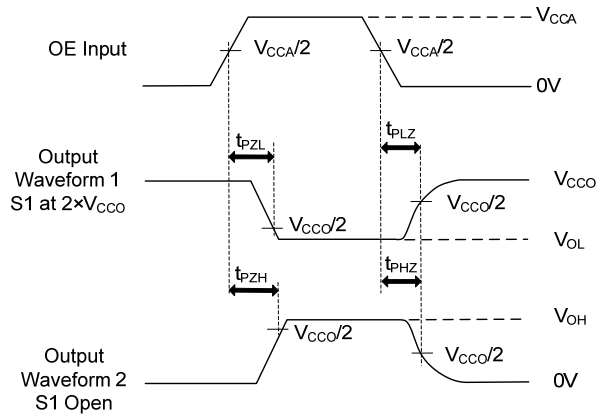
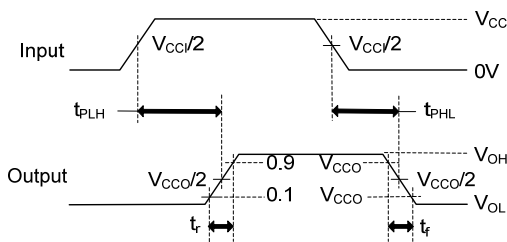
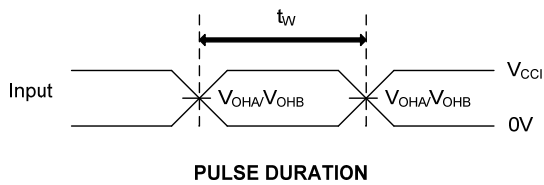

- Notes:
1.  $C_L$  includes probe and jig capacitance.
  2. The outputs are measured one at a time, with one transition per measurement.
  3.  $t_{PLH}$  and  $t_{PHL}$  are the same as  $t_{PD}$ .
  4.  $V_{CCI}$  is the  $V_{CC}$  associated with the input port.
  5.  $V_{CCO}$  is the  $V_{CC}$  associated with the output port.
  6. All parameters and waveforms are not applicable to all devices.

■ DETAILED DESCRIPTION

**Overview**

The **UTXB0104** device is a 4-bit, directionless voltage-level translator specifically designed for translating logic voltage levels. The A port is able to accept I/O voltages ranging from 1.2V to 3.6V, while the B port can accept I/O voltages from 1.65V to 5.5V. The device is a buffered architecture with edge-rate accelerators (one-shots) to improve the overall data rate. This device can only translate push-pull CMOS logic outputs. If for open-drain signal translation, please refer to the **UTC UTXS010X** products.

**Architecture**

The **UTXB0104** architecture (see Figure 1) does not require a direction-control signal to control the direction of data flow from A to B or from B to A. In a dc state, the output drivers of the **UTXB0104** can maintain a high or low, but are designed to be weak, so that they can be overdriven by an external driver when data on the bus starts flowing the opposite direction.

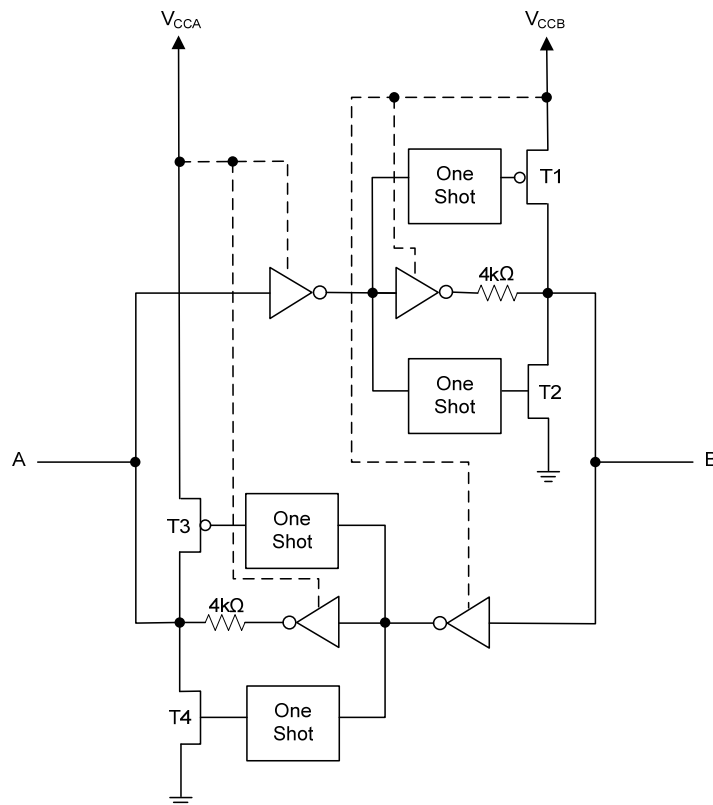

**Figure 1. Architecture of UTXB0104 I/O Cell**

The output one-shots detect rising or falling edges on the A or B ports. During a rising edge, the one-shot turns on the PMOS transistors (T1, T3) for a short duration, which speeds up the low-to-high transition. Similarly, during a falling edge, the one-shot turns on the NMOS transistors (T2, T4) for a short duration, which speeds up the high-to-low transition. The typical output impedance during output transition is 70Ω at V<sub>CC0</sub> = 1.2V to 1.8V, 50Ω at V<sub>CC0</sub> = 1.8V to 3.3V, and 40Ω at V<sub>CC0</sub> = 3.3V to 5V.

**Enable and Disable**

The **UTXB0104** has an OE input that is used to disable the device by setting OE=LOW, which places all I/Os in the high-impedance (Hi-Z) state. The disable time (t<sub>dis</sub>) indicates the delay between when OE goes low and when the outputs acutally get disabled (Hi-Z). The enable time (t<sub>en</sub>) indicates the amount of time the user must allow for the one-shot circuitry to become operational after OE is taken high.

## ■ DETAILED DESCRIPTION (Cont.)

### Pull-up or Pull-down Resistors on I/O Lines

The **UTXB0104** is designed to drive capacitive loads of up to 70pF. The output drivers of the **UTXB0104** have low dc drive strength. If pullup or pulldown resistors are connected externally to the data I/Os, their values must be kept higher than 50 k $\Omega$  to ensure that they do not contend with the output drivers of the **UTXB0104**. For the same reason, the **UTXB0104** should not be used in applications such as I<sup>2</sup>C or 1-Wire where an open-drain driver is connected on the bidirectional data I/O. For these applications, use a device from the UTC UTXS01xx series of level translators.

### Device Functional Modes

The **UTXB0104** device has two functional modes, enabled and disabled. To disable the device, set the OE input to low, which places all I/Os in a high impedance state. Setting the OE input to high will enable the device.

### Power Supply Recommendations

During operation, ensure that  $V_{CCA} \leq V_{CCB}$  at all times. During power-up sequencing,  $V_{CCA} \geq V_{CCB}$  does not damage the device, so any power supply can be ramped up first. The **UTXB0104** has circuitry that disables all output ports when either  $V_{CC}$  is switched off ( $V_{CCA/B} = 0V$ ). The output-enable (OE) input circuit is designed so that it is supplied by  $V_{CCA}$  and when the (OE) input is low, all outputs are placed in the high-impedance state. To ensure the high-impedance state of the outputs during power up or power down, the OE input pin must be tied to GND through a pull-down resistor and must not be enabled until  $V_{CCA}$  and  $V_{CCB}$  are fully ramped and stable. The minimum value of the pull-down resistor to ground is determined by the current-sourcing capability of the driver.

■ TYPICAL APPLICATION CIRCUIT

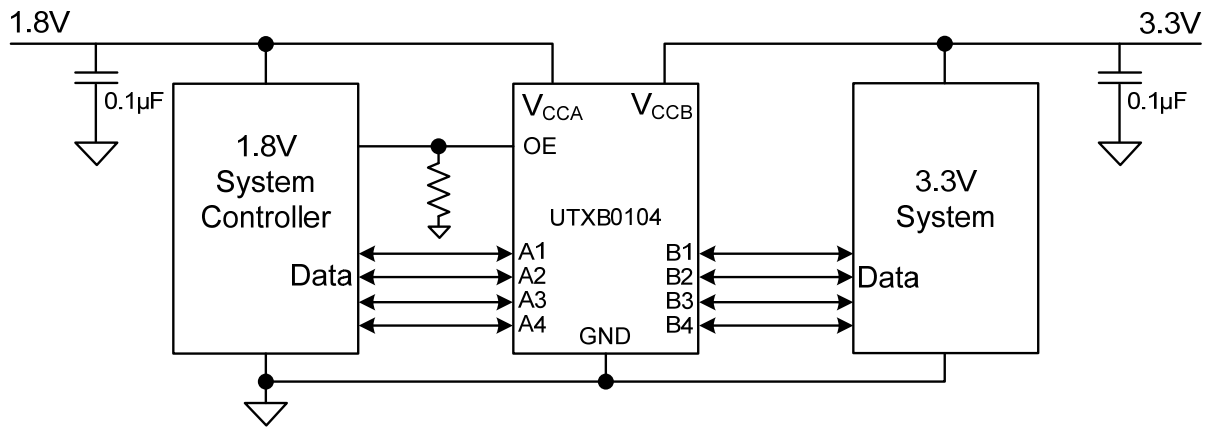

UTC assumes no responsibility for equipment failures that result from using products at values that exceed, even momentarily, rated values (such as maximum ratings, operating condition ranges, or other parameters) listed in products specifications of any and all UTC products described or contained herein. UTC products are not designed for use in life support appliances, devices or systems where malfunction of these products can be reasonably expected to result in personal injury. Reproduction in whole or in part is prohibited without the prior written consent of the copyright owner. UTC reserves the right to make changes to information published in this document, including without limitation specifications and product descriptions, at any time and without notice. This document supersedes and replaces all information supplied prior to the publication hereof.