

# DALLAS SEMICONDUCTOR

## DS2108 Differential SCSI Switchable Terminator

### FEATURES

- Fully compliant with SCSI, SCSI-2 and SCSI-3 standards
- Conforms to EIA RS-485 standard
- Provides differential termination for 9 pairs of signal lines
- Operates with SCSI signal voltages of -7 to +12 Volts
- Laser-trimmed 330 and 150 ohm termination resistors have  $\pm 5\%$  tolerance over full temperature range
- Switchable power down mode
- Low power down capacitance of 6 pF
- 24-pin plastic SOIC (DS2108S)

### PIN ASSIGNMENT

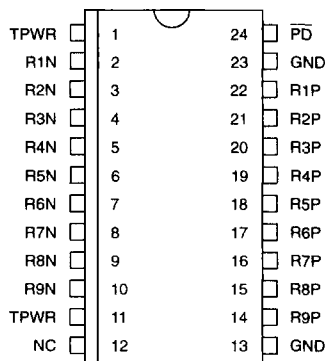

DS2108S 24-PIN SOIC (300 MIL)

### DESCRIPTION

The DS2108 SCSI Terminator has been specifically designed for Differential SCSI systems requiring switchable termination. The DS2108 integrates eighteen 330 ohm and nine 150 ohm precise switched termination resistors into a monolithic IC. The surface mount SOIC package saves board space over conventional resistor SIPs. The termination resistors can be isolated from the SCSI bus under software or hardware control. While in the powered down mode, the DS2108 isolates the 9 terminator blocks from the bus while adding only 6 pF capacitance to each signal line of the SCSI bus.

### FUNCTIONAL DESCRIPTION

The DS2108 consists of power down circuitry, eighteen 330 ohm and nine 150 ohm termination resistors (Figure 1). The DS2108 can be removed from the circuit by bringing the power down pin ( $\overline{\text{PD}}$ ) low. The power down capacitance on the terminating resistors is 6 pF, well below the SCSI-3 allotment of 25 pF. The DS2108 supports SCSI signal voltages of -7 to +12 volts when powered on or off. When all lines settle into the quiescent state (no signal transitions), 56 mA is typically consumed. Only 1 mA is typically consumed in the powered down mode.

DS2108 BLOCK DIAGRAM Figure 1

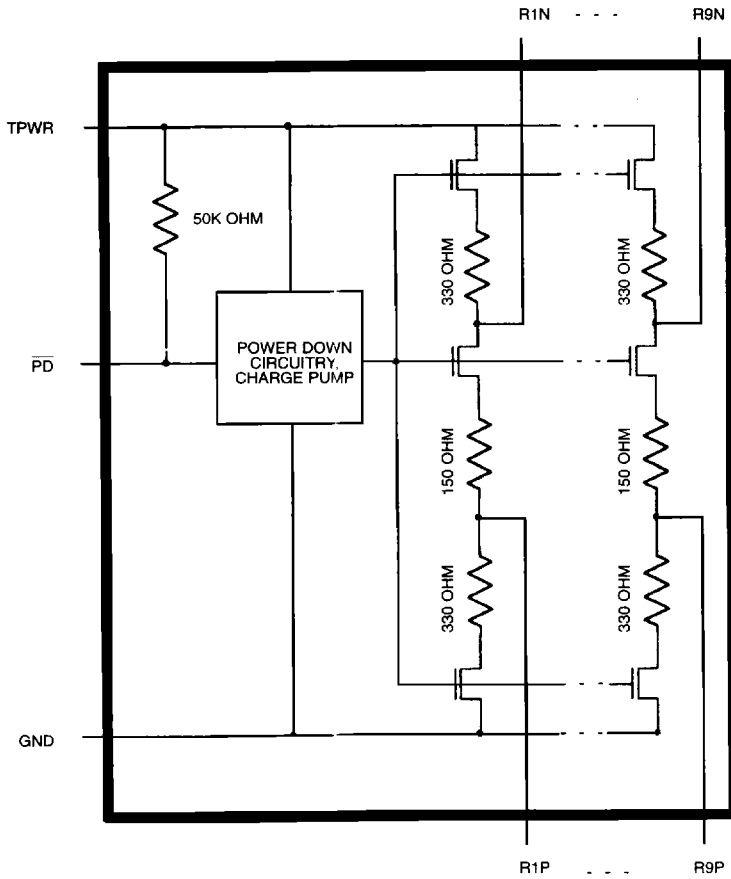

## TYPICAL DIFFERENTIAL SCSI BUS CONFIGURATION Figure 2

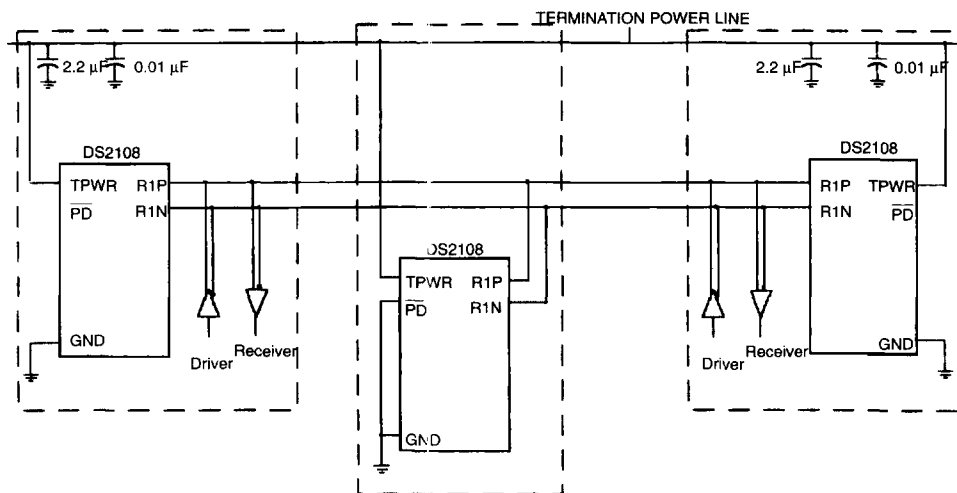

### NOTES:

- Two DS2108s required per 8-bit SCSI device and three DS2108s per 16-bit SCSI device.
- Mid-bus termination effectively removed by grounding  $\overline{\text{PD}}$  pin.
- Termination power to be provided as specified in SCSI-3 Parallel Interface (SPI) document.
- Local TERMPWR bypassing is recommended by the SPI document with values shown. The bypass capacitors should be located as close as possible to the DS2108s. Only one pair of capacitors is required per SCSI device (may be shared between DS2108s on same device).

### PIN DESCRIPTION Table 1

PIN	SYMBOL	DESCRIPTION
1, 11	TPWR	Termination Power. Should be connected to the SCSI TERMPWR line. Bypass with a 2.2 $\mu\text{F}$ cap in parallel with a 0.1 $\mu\text{F}$ cap as shown in Figure 2.
2, 3, 4, 5, 6, 7, 8, 9, 10	R1N...R9N	Signal Termination Negative. Connect to -SIGNAL of SCSI bus.
12	NC	No Connect. Do not connect any signal to this pin.
13, 23	GND	Ground. Signal ground; 0.0V.
14, 15, 16, 17, 18, 19, 20, 21, 22	R1P...R9P	Signal Termination Positive. Connect to +SIGNAL of SCSI bus.
24	$\overline{\text{PD}}$	Power Down. When tied low, the DS2108 enters a power-down mode. Contains an internal 50K pullup. Strap low to deactivate the DS2108, leave open circuited to activate the DS2108.

**ABSOLUTE MAXIMUM RATINGS\***

Voltage on Any Pin Relative to Ground	-7.0V to +12.0V
Operating Temperature	0°C to 70°C
Storage Temperature	-55°C to 125°C
Soldering Temperature	260°C for 10 seconds

\* This is a stress rating only and functional operation of the device at these or any other conditions above those indicated in the operation sections of this specification is not implied. Exposure to absolute maximum rating conditions for extended periods of time may affect reliability.

**RECOMMENDED OPERATING CONDITIONS**

(0°C to 70°C)

PARAMETER	SYMBOL	MIN	TYP	MAX	UNITS	NOTES
TERMPWR Voltage	$V_{TP}$	4.00		5.25	V	
$\overline{PD}$ Active	$V_{PDA}$	-0.3		0.8	V	
$\overline{PD}$ Inactive	$V_{PDI}$	2.00		$V_{TP}+0.3$	V	

**DC CHARACTERISTICS**

(0°C to 70°C)

PARAMETER	SYMBOL	MIN	TYP	MAX	UNITS	NOTES
TERMPWR Current	$I_{TP}$		56	65	mA	1, 6
Power Down Current	$I_{PD}$		1	2	mA	1, 5
Termination Resistance	$R_{TTN}$	313.5	330	346.5	ohms	2
Termination Resistance	$R_{TNP}$	142.5	150	157.5	ohms	3
Termination Resistance	$R_{TPG}$	313.5	330	346.5	ohms	4
Power Down Termination Capacitance	$C_{PD}$		5	6	pF	1, 5, 7

**NOTES:**

1.  $4.00V < TERMPWR < 5.25V$
2. 330  $\Omega$  resistor between TERMPWR and -SIGNAL.
3. 150  $\Omega$  resistor between -SIGNAL and +SIGNAL.
4. 330  $\Omega$  resistor between +SIGNAL and GDN.
5.  $\overline{PD} = 0.0V$ .
6. Signal pins left open.
7. Guaranteed by design; not production tested.

## 24-PIN SOIC (300 MIL)

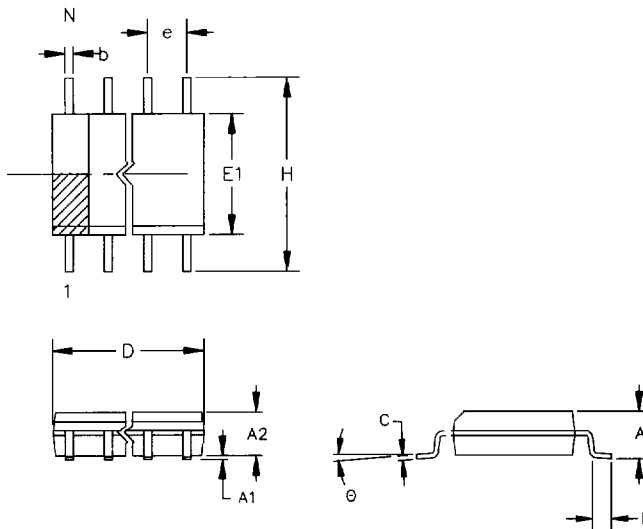

The chamfer on the body is optional. If it is not present, a terminal 1 identifier must be positioned so that 1/2 or more of its area is contained in the hatched zone.

PKG	24-PIN	
DIM	MIN	MAX
A IN. MM	0.094 2.38	0.105 2.68
A1 IN. MM	0.004 0.102	0.012 0.30
A2 IN. MM	0.089 2.26	0.095 2.41
b IN. MM	0.013 0.33	0.020 0.51
C IN MM	0.009 0.229	0.013 0.33
D IN. MM	0.598 15.19	0.612 15.54
e IN. MM	.050 BSC 1.27 BSC	
E1 IN. MM	0.290 7.37	0.300 7.62
H IN MM	0.398 10.11	0.416 10.57
L IN MM	0.016 0.40	0.040 1.02
$\theta$	0°	8°