

Silicon Darlington Phototransistor

Description

BPX99R is an extra high sensitive monolithic silicon epitaxial planar Darlington phototransistor in a hermetically sealed low profile TO-46 metal case.

The solid metal base allows the user to mount the device on a heatsink and take advantage of the high current capability (500 mA). A glass lens provides a viewing angle of $\pm 12^\circ$ and makes the device insensible to ambient stray-light.

A base terminal is available to enable biasing and sensitivity control.

Features

- Hermetically sealed case
- Angle of half sensitivity $\phi = \pm 12^\circ$
- Base terminal available
- Collector light current up to 500 mA
- Extra high photo sensitivity
- Suitable for visible and near infrared radiation

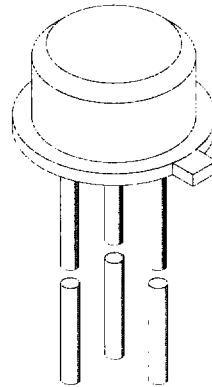

94 x 584

Applications

Direct driving of relays, magnetic valves, small motors etc.

Absolute Maximum Ratings

$T_{amb} = 25^\circ\text{C}$

Parameter	Test Conditions	Symbol	Value	Unit
Collector Emitter Voltage		V_{CEO}	40	V
Emitter Base Voltage		V_{EBO}	10	V
Collector Current		I_C	0.5	A
Peak Collector Current	$t_p/T = 0.05$, $t_p \leq 10$ ms	I_{CM}	1	A
Total Power Dissipation	$T_{amb} \leq 25^\circ\text{C}$	P_{tot}	0.33	W
Total Power Dissipation	$T_{case} \leq 45^\circ\text{C}$	P_{tot}	1.6	W
Junction Temperature		T_j	125	$^\circ\text{C}$
Operating Temperature Range		T_{amb}	-55...+125	$^\circ\text{C}$
Thermal Resistance Junction/Ambient		R_{thJA}	300	K/W
Thermal Resistance Junction/Case		R_{thJC}	50	K/W

Basic Characteristics

$T_{amb} = 25^{\circ}\text{C}$

Parameter	Test Conditions	Symbol	Min	Typ	Max	Unit
Collector Emitter Breakdown Voltage	$I_C = 1\text{ mA}$	$V_{(BR)CEO}$	40			V
Collector Dark Current	$V_{CE} = 20\text{ V}, E = 0$	I_{CEO}		10	200	nA
Collector Light Current	$E_c = 0.3\text{ mW/cm}^2, \lambda = 950\text{ nm}, V_{CE} = 5\text{ V}$	I_{ca}	4	15		mA
Angle of Half Sensitivity		φ		± 12		deg
Wavelength of Peak Sensitivity		λ_p		800		nm
Range of Spectral Bandwidth		$\lambda_{0.5}$		590...950		nm
Collector Emitter Saturation Voltage	$E_c = 0.3\text{ mW/cm}^2, \lambda = 950\text{ nm}, I_C = 0.1\text{ mA}$	V_{CEsat}		0.75	1	V
Turn-On Time	$V_S = 5\text{ V}, I_C = 10\text{ mA}, R_L = 100\Omega$	t_{on}		40		μs
Turn-Off Time	$V_S = 5\text{ V}, I_C = 10\text{ mA}, R_L = 100\Omega$	t_{off}		50		μs

Typical Characteristics ($T_{amb} = 25^{\circ}\text{C}$ unless otherwise specified)

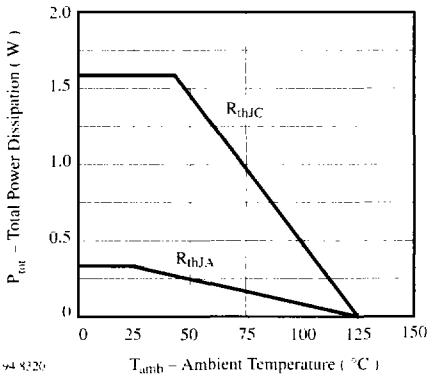

Figure 1. Total Power Dissipation vs. Ambient Temperature

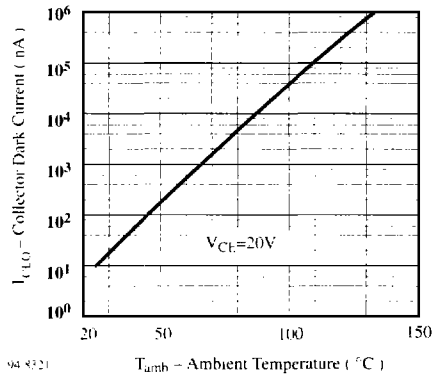

Figure 2. Collector Dark Current vs. Ambient Temperature

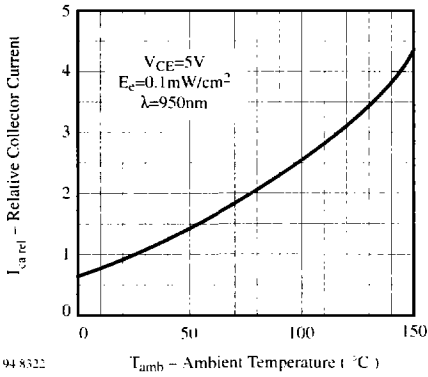

Figure 3. Relative Collector Current vs. Ambient Temperature

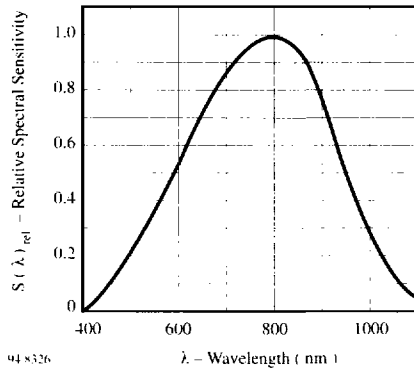

Figure 6. Relative Spectral Sensitivity vs. Wavelength

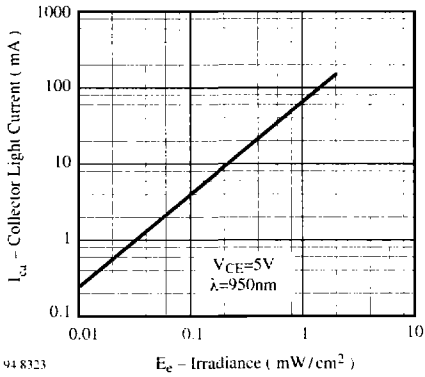

Figure 4. Collector Light Current vs. Irradiance

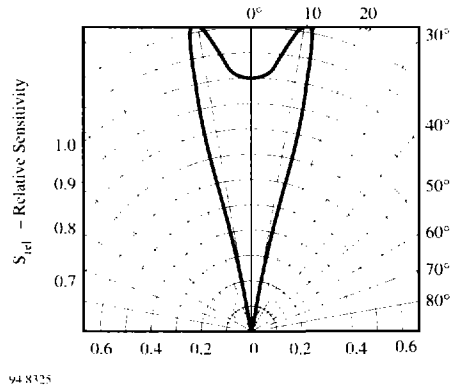

Figure 7. Relative Radiant Sensitivity vs. Angular Displacement

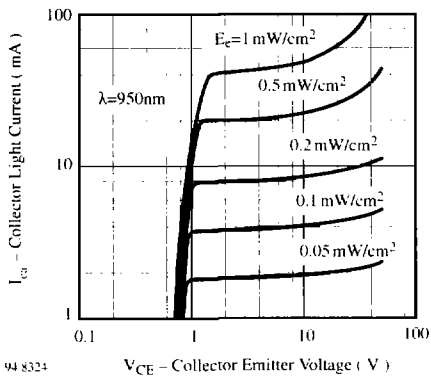
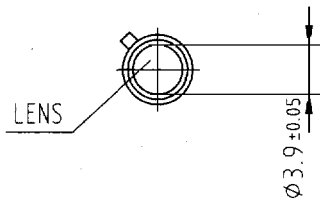
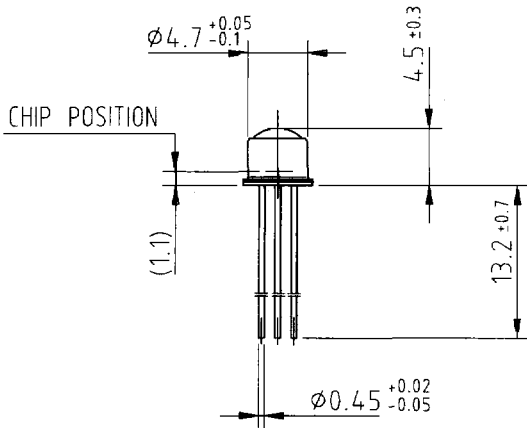
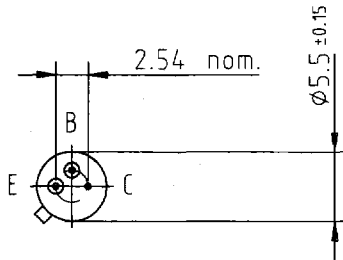
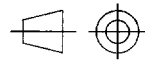

Figure 5. Collector Light Current vs. Collector Emitter Voltage

Dimensions in mm



96 12176



technical drawings
according to DIN
specifications

