

2N4856JAN/JANTX/JANTXV Series

TEMIC
Semiconductors

N-Channel JFETs

2N4856JAN	2N4856JANTX	2N4856JANTXV
2N4857JAN	2N4857JANTX	2N4857JANTXV
2N4858JAN	2N4858JANTX	2N4858JANTXV
2N4859JAN	2N4859JANTX	2N4859JANTXV
2N4860JAN	2N4860JANTX	2N4860JANTXV
2N4861JAN	2N4861JANTX	2N4861JANTXV

Product Summary

Part Number	V _{GS(off)} (V)	V _{(BR)GSS} Min (V)	r _{DS(on)} Max (Ω)	I _{D(off)} Max (pA)	t _{ON} Typ (ns)
2N4856	-4 to -10	-40	25	250	9
2N4857	-2 to -6	-40	40	250	10
2N4858	-0.8 to -4	-40	60	250	20
2N4859	-4 to -10	-30	25	250	9
2N4860	-2 to -6	-30	40	250	10
2N4861	-0.8 to -4	-30	60	250	20

Features

- Low On-Resistance: 2N4856 <25 Ω
- Fast Switching—t_{ON}: 4 ns
- High Off-Isolation—I_{D(off)}: 5 pA
- Low Capacitance: 3 pF
- Low Insertion Loss
- N-Channel Majority Carrier FET

Benefits

- Low Error Voltage
- High-Speed Analog Circuit Performance
- Negligible "Off-Error," Excellent Accuracy
- Good Frequency Response, Low Glitches
- Eliminates Additional Buffering
- High Radiation Tolerance

Applications

- Analog Switches
- Choppers
- Sample-and-Hold
- Normally "On" Switches
- Current Limiters

Description

The 2N4856JAN/JANTX/JANTXV all-purpose JFET analog switches offer low on-resistance, low capacitance, good isolation, and fast switching.

Hermetically-sealed TO-206AA (TO-18) packaging allows full military processing (see Military Information). For similar products in TO-226AA (TO-92) and TO-236 (SOT-23) packages, see the J/SST111 series data sheet. For similar duals, see the 2N5564/5565/5566 data sheet.

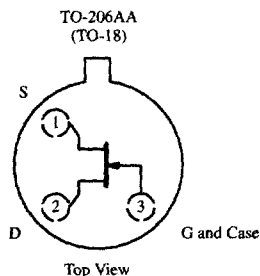

Updates to this data sheet may be obtained via facsimile by calling Siliconix FaxBack, 1-408-970-5600. Please request FaxBack document #70244.

Absolute Maximum Ratings

Gate-Drain, Gate-Source Voltage :
 (2N4856-58) -40 V
 (2N4859-61) -30 V
 Gate Current 50 mA
 Lead Temperature ($1/16''$ from case for 10 seconds) 300 °C
 Storage Temperature -65 to 200°C

Operating Junction Temperature -65 to 200°C
 Power Dissipation^a 1800 mW

Notes
 a. Derate 10.3 mW/°C to T_C > 25°C

Specifications^a for 2N4856, 2N4857 and 2N4858

Parameter	Symbol	Test Conditions	Typ ^b	Limits						Unit
				2N4856		2N4857		2N4858		
				Min	Max	Min	Max	Min	Max	
Static										
Gate-Source Breakdown Voltage	V _{(BR)GSS}	I _G = -1 μA, V _{DS} = 0 V	-55	-40		-40		-40		V
Gate-Source Cutoff Voltage	V _{GS(off)}	V _{DS} = 15 V, I _D = 0.5 nA		-4	-10	-2	-6	-0.8	-4	
Saturation Drain Current ^c	I _{DSS}	V _{DS} = 15 V, V _{GS} = 0 V		50	175	20	100	8	80	mA
Gate Reverse Current	I _{GSS}	V _{GS} = -20 V, V _{DS} = 0 V	-5		-250		-250		-250	pA
		T _A = 150°C	-13		-500		-500		-500	nA
Gate Operating Current ^d	I _G	V _{DG} = 15 V, I _D = 10 mA	-5							pA
Drain Cutoff Current	I _{D(off)}	V _{DS} = 15 V, V _{GS} ≈ -10 V	5		250		250		250	nA
		T _A = 150°C	13		500		500		500	nA
Drain-Source On-Voltage	V _{DS(on)}	V _{GS} = 0 V	I _D = 5 mA	0.25					0.5	V
			I _D = 10 mA	0.35			0.5			
			I _D = 20 mA	0.5		0.75				
Drain-Source On-Resistance ^d	r _{DS(on)}	V _{GS} = 0 V, I _D = 1 mA			25		40		60	Ω
Gate-Source Forward Voltage ^d	V _{GS(F)}	I _G = 1 mA, V _{DS} = 0 V	0.7							V
Dynamic										
Common-Source Forward Transconductance ^d	g _{fs}	V _{DG} = 20 V, I _D = 1 mA f = 1 kHz	6							mS
Common-Source Output Conductance ^d	g _{os}		25							μS
Common-Source Input Capacitance	C _{iss}	V _{DS} = 0 V, V _{GS} = -10 V f = 1 MHz	7		18		18		18	pF
Common-Source Reverse Transfer Capacitance	C _{rss}		3		8		8		8	
Equivalent Input Noise Voltage ^d	e _n	V _{DG} = 10 V, I _D = 10 mA f = 1 kHz	3							nV/ √Hz
Switching										
Turn-On Time	t _{d(on)}	V _{DD} = 10 V, V _{GS(H)} = 0 V See Switching Circuit	2		6		6		10	ns
	t _r		2		3		4		10	
Turn-Off Time	t _{OFF}		13		25		50		100	

7
N-Channel JFETs

2N4856JAN/JANTX/JANTXV Series



Specifications^a for 2N4859, 2N4860 and 2N4861

Parameter	Symbol	Test Conditions	Typ ^b	Limits						Unit
				2N4859		2N4860		2N4861		
				Min	Max	Min	Max	Min	Max	
Static										
Gate-Source Breakdown Voltage	$V_{(BR)GSS}$	$I_G = -1 \mu A, V_{DS} = 0 V$	-55	-30		-30		-30		V
Gate-Source Cutoff Voltage	$V_{GS(off)}$	$V_{DS} = 15 V, I_D = 0.5 nA$		-4	-10	-2	-6	-0.8	-4	
Saturation Drain Current ^c	I_{DSS}	$V_{DS} = 15 V, V_{GS} = 0 V$		50	175	20	100	8	80	mA
Gate Reverse Current	I_{GSS}	$V_{GS} = -15 V, V_{DS} = 0 V$ $T_A = 150^\circ C$	-5		-250		-250		-250	pA
			-13		-500		-500		-500	nA
Gate Operating Current ^d	I_G	$V_{DG} = 15 V, I_D = 10 mA$	-5							pA
Drain Cutoff Current	$I_{D(off)}$	$V_{DS} = 15 V, V_{GS} = -10 V$ $T_A = 150^\circ C$	5		250		250		250	pA
			13		500		500		500	nA
Drain-Source On-Voltage	$V_{DS(on)}$	$V_{GS} = 0 V$	$I_D = 5 mA$	0.25					0.5	V
			$I_D = 10 mA$	0.35			0.5			
			$I_D = 20 mA$	0.5		0.75				
Drain-Source On-Resistance	$r_{DS(on)}$	$V_{GS} = 0 V, I_D = 1 mA$			25		40		60	Ω
Gate-Source Forward Voltage	$V_{GS(F)}$	$I_G = 1 mA, V_{DS} = 0 V$	0.7							V
Dynamic										
Common-Source Forward Transconductance ^d	g_{fs}	$V_{DG} = 20 V, I_D = 1 mA$ $f = 1 kHz$	6							mS
Common-Source Output Conductance ^d	g_{os}		25							μS
Common-Source Input Capacitance	C_{iss}	$V_{DS} = 0 V, V_{GS} = -10 V$ $f = 1 MHz$	7		18		18		18	pF
Common-Source Reverse Transfer Capacitance	C_{rss}		3		8		8		8	
Equivalent Input Noise Voltage ^d	\bar{e}_n	$V_{DG} = 10 V, I_D = 10 mA$ $f = 1 kHz$	3							nV/ \sqrt{Hz}
Switching										
Turn-On Time	$t_{d(on)}$	$V_{DD} = 10 V, V_{GS(H)} = 0 V$ See Switching Circuit	2		6		6		10	ns
	t_r		2		3		4		10	
Turn-Off Time	t_{off}		19		25		50		100	

Notes

- $T_A = 25^\circ C$ unless otherwise noted.
- Typical values are for DESIGN AID ONLY, not guaranteed nor subject to production testing.
- Pulse test: $PW \leq 100 \mu s$ duty cycle $\leq 10\%$.
- This parameter not registered with JEDEC.

NCB

Switching Time Test Circuit

	4856/4859	4857/4860	4858/4861
$V_{GS(L)}$	-10 V	-6 V	-4 V
R_L^*	464 Ω	953 Ω	1910 Ω
$I_{D(on)}$	20 mA	10 mA	5 mA

*Non-inductive

Input Pulse

Rise Time < 1 ns
Fall Time < 1 ns
Pulse Width 100 ns
PRF 1 MHz

Sampling Scope

Rise Time 0.4 ns
Input Resistance 10 M Ω
Input Capacitance 1.5 pF

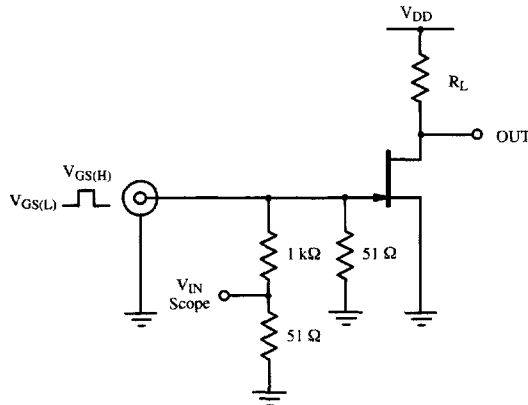
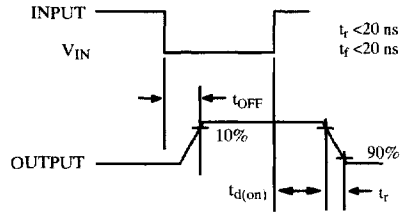

7
N-Channel JFETs