

Power Amplifiers

SA1068A

**CDMA 6.3-Watt
1.93 GHz to 1.99 GHz
Linear Power Amplifier Module**

- *6.3 Watts CDMA IS-95*
- *+45 dBm P1dB*
- *45 dB Gain*
- *-30°C to +85°C*

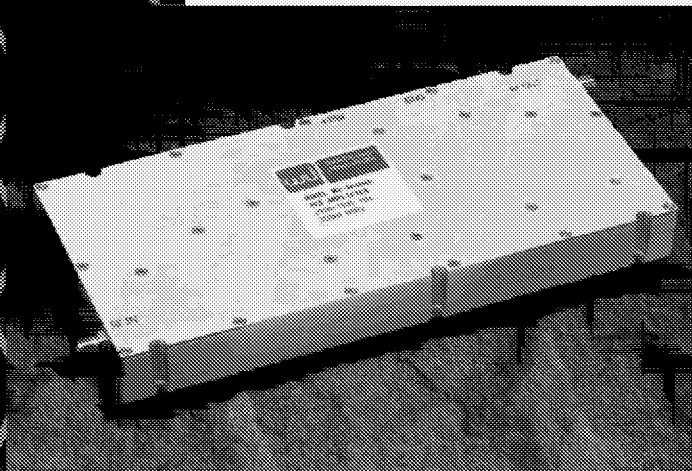

OUTLINE DRAWING

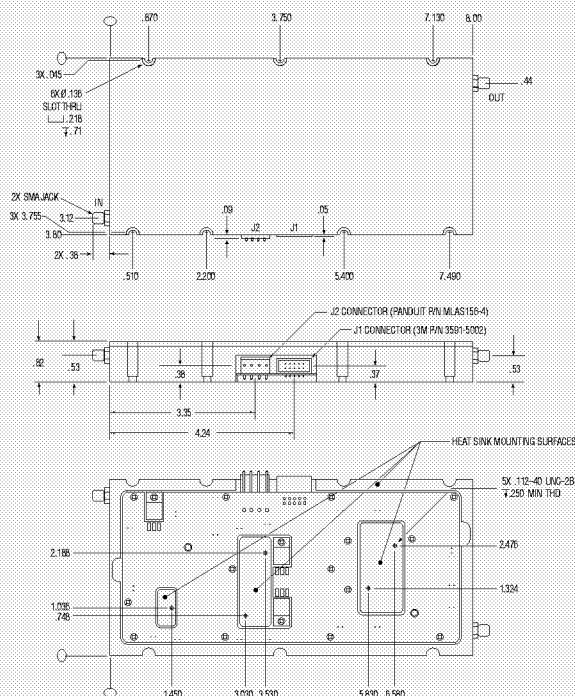

Watkins-Johnson's SA1068A Power Amplifier provides exceptional linearity for CDMA digital modulation applications. Utilizing WJ's GaAs amplifiers driving bipolar transistors in the class AB output stage, the SA1068A achieves a high third-order intercept point combined with superior efficiency when compared to an equivalent power class A amplifier. Special non-linear design techniques are utilized to minimize unwanted adjacent channel power. To aid top level system diagnostics and reliability, the unit includes alarms to identify if an active part fails or if a poor load is presented to the RF output. In the event that a fault is detected or to simply save DC power, a digitally controlled shutdown is provided. An integral logarithmic power detector measures the output power of the amplifier over a 16 dB dynamic range.

The Wireless Edge™



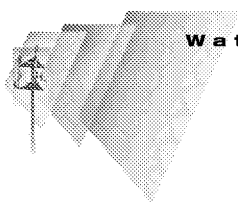

Power Amplifiers

SA1068A CDMA 6.3-Watt 1.93 GHz to 1.99 GHz Linear Power Amplifier Module

Specifications

Parameters	Typical Level	Specified Limits
Frequency		1.930-1.990 GHz
Pout at 1 dB Gain Compression	+45 dBm	
Gain (small signal at +25°C)		45 ±1.0 dB
Gain Variation over Temp (-40 to +85°C). Variation is relative to G(+25°C)		±1.5 dB
CDMA Adjacent Channel Power Rejection (ACPR) ¹ First channel ACP Rejection (885 KHz offset from f _c , in a 30 KHz integration BW) Pout ≤ -38 dBm	-47 dB	-45 dB
Spurious Suppression Outside Frequency Block		
a) ACP level at 1.25 to 2.25 MHz offset from f _c , in a 12.5 KHz integration BW. Pout ≤ 38.0 dBm	-14 dBm	-13 dBm
b) ACP level at 2.25 to 3.25 MHz offset from f _c , in a 1.0 MHz integration BW. Pout ≤ 38.0 dBm	-14 dBm	-13 dBm
Third-Order 2-Tone Output Intermodulation Product Rejection (Pout = +37 dBm per CW tone)	-35 dB	-30 dB
Maximum Noise Figure	5.0 dB	6.5 dB
Input & Output Impedence		50 Ohm
Return Loss (1.930-1.990 GHz) Input and Output	-20 dB	-15 dB
Load Mismatch Sustainable Without Damage		3.0:1
Output Power Monitor		
a) Pout = +40 dBm CW	4.5 V	5.0 V max, 4.0 V min
b) Pout = +32 dBm CW	2.5 V	3.0 V max, 2.0 V min
c) Pout = +24 dBm CW	0.5 V	1.0 V max, 0.0 V min
Supply Voltages	+24 V	23.5 - 26.5 V
Maximum Supply Without Damage, +24 volt supply		+28 VDC
Maximum DC Current (+38 dBm Pout), +24 volt supply	4.1 A	4.5 A
Maximum DC Power Dissipation, +24 volt supply	100 Watts	110 Watts
RF Connectors	SMA Female	
Stability (No spurious outputs above -50 dBm)	Unconditionally stable for all loads	
Size (Heat sink not included)	0.82" (H), 3.80" (W), 8.00" (L)	
Weight (Heat sink not included)	625 grams (22 oz.)	

Note: 1. CDMA adjacent channel power and spurious measurements are made using a Rohde & Schwarz SMIQ 03 source in an IS-95 forward link.

The Wireless Edge™