

HD74HC4022 ● Octal Counters/Dividers

The HD74HC4022 is a four-stage Johnson octal counter with builtin code converter. High speed operation and spike-free outputs are obtained by use of a Johnson octal counter design. The eight decoded outputs are normally low, and go high only at their appropriate octal time period. The output changes occur on the positive-going edge of the clock pulse. This part can be used in frequency division applications as well as octal counter or octal decode display applications.

■ FEATURES

- High Speed Operation
- High Output Current: Fanout of 10 LSTTL Loads
- Wide Operating Voltage: $V_{CC}=2\sim 6V$
- Low Input Current: $1\mu A$ max.
- Low Quiescent Supply Current: I_{CC} (static) = $4\mu A$ max. ($T_a=25^\circ C$)

■ PIN ARRANGEMENT

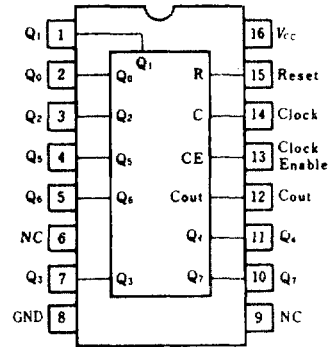

(Top View)

■ FUNCTION TABLE

Clock	Clock Enable	Reset	Output n
L	x	L	n
x	H	L	n
	L	L	n + 1
	x	L	n
H		L	n + 1
x		L	n
x	x	H	Q_0

X: irrelevant
 $n < 4 \dots$ Carry = H
 $n \geq 4 \dots$ Carry = L

■ LOGIC DIAGRAM

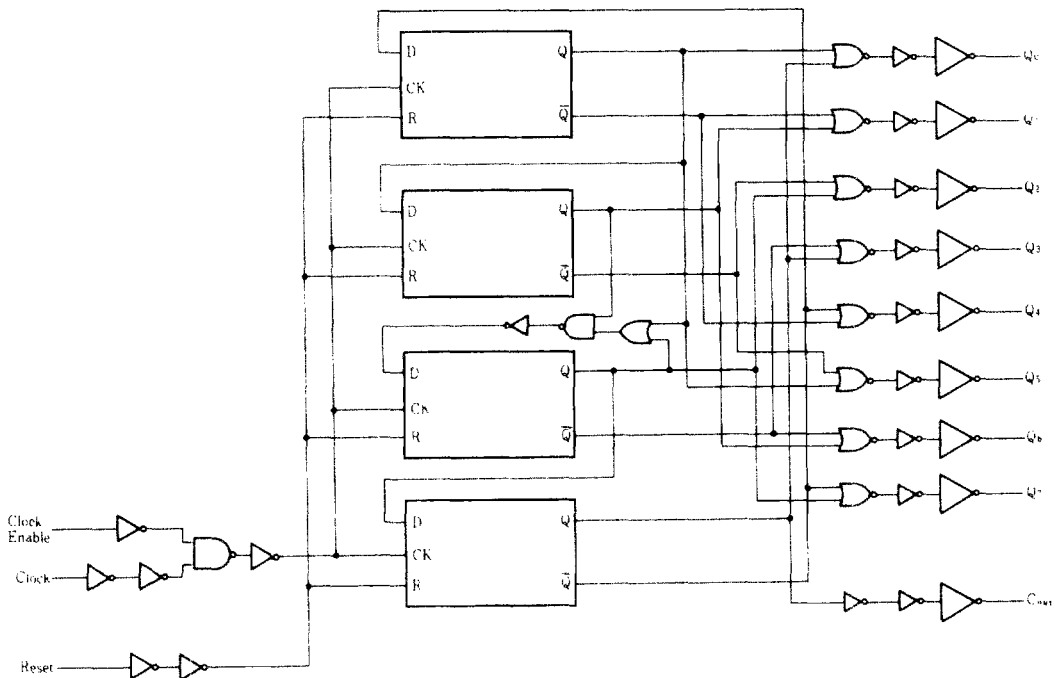

■ DC CHARACTERISTICS

Item	Symbol	V _{CC} (V)	Test Conditions	T _a = 25°C			T _a = -40 ~ +85°C		Unit	
				min	typ	max	min	max		
Input Voltage	V _{IH}	2.0		1.5	-	-	1.5	-	V	
		4.5		3.15	-	-	3.15	-		
		6.0		4.2	-	-	4.2	-		
	V _{IL}	2.0		-	-	0.5	-	0.5	V	
		4.5		-	-	1.35	-	1.35		
		6.0		-	-	1.8	-	1.8		
Output Voltage	V _{OH}	2.0	V _{in} = V _{IH} or V _{IL}	I _{OH} = -20μA	1.9	2.0	-	1.9	-	V
		4.5			4.4	4.5	-	4.4	-	
		6.0			5.9	6.0	-	5.9	-	
		4.5		I _{OH} = -4mA	4.18	-	-	4.13	-	
		6.0		I _{OH} = -5.2mA	5.68	-	-	5.63	-	
		V _{OL}		2.0	V _{in} = V _{IH} or V _{IL}	I _{OL} = 20μA	-	0.0	0.1	
	4.5		-	0.0			0.1	-	0.1	
	6.0		-	0.0			0.1	-	0.1	
	4.5		I _{OL} = 4mA	-		-	0.26	-	0.33	
	6.0		I _{OL} = 5.2mA	-		-	0.26	-	0.33	
	Input Current		I _{in}	6.0		V _{in} = V _{CC} or GND	-	-	±0.1	-
	Quiescent Supply Current	I _{CC}	6.0	V _{in} = V _{CC} or GND, I _{out} = 0μA	-	-	4.0	-	40	μA

■ AC CHARACTERISTICS (C_L = 50pF, Input t_r = t_f = 6ns)

Item	Symbol	V _{CC} (V)	Test Conditions	T _a = 25°C			T _a = -40 ~ +85°C		Unit
				min.	typ.	max.	min.	max.	
Maximum Clock Frequency	f _{max}	2.0		-	-	6	-	5	MHz
		4.5		-	-	31	-	27	
		6.0		-	-	36	-	31	
Propagation Delay Time	t _{PLH} t _{PHL}	2.0	Clock to Q	-	-	230	-	290	ns
		4.5		-	19	46	-	58	
		6.0		-	-	39	-	49	
	t _{PLH} t _{PHL}	2.0	Reset to Q	-	-	230	-	290	ns
		4.5		-	16	46	-	58	
		6.0		-	-	39	-	49	
	t _{PLH} t _{PHL}	2.0	Clock to Cout	-	-	230	-	290	ns
		4.5		-	-	46	-	58	
		6.0		-	-	39	-	49	
	t _{PLH} t _{PHL}	2.0	Reset to Cout	-	-	230	-	290	ns
		4.5		-	13	46	-	58	
		6.0		-	-	39	-	49	
Pulse Width	t _w	2.0		80	-	-	100	-	ns
		4.5		16	7	-	20	-	
		6.0		14	-	-	17	-	
Setup Time	t _{su}	2.0		50	-	-	65	-	ns
		4.5		10	-	-	13	-	
		6.0		9	-	-	11	-	
Hold Time	t _h	2.0		75	-	-	95	-	ns
		4.5		15	-	-	19	-	
		6.0		13	-	-	16	-	
Removal Time	t _{rem}	2.0		75	-	-	95	-	ns
		4.5		15	-3	-	19	-	
		6.0		13	-	-	16	-	
Output Rise/Fall Time	t _{TLH} t _{THL}	2.0		-	-	75	-	95	ns
		4.5		-	-	15	-	19	
		6.0		-	-	13	-	16	
Input Capacitance	C _{in}	-		-	5	10	-	10	pF