

High-side Power Switch ICs [With Diagnostic Function, 3-circuits] SLA2501M

Features

- Built-in diagnostic function to detect short and open circuiting of loads and output status signals
- Low saturation PNP transistor use ($V_{CE(sat)} \leq 0.2V$)
- Allows direct driving using LS-TTL and C-MOS logic levels
- Built-in Zener diode in transistor eliminates the need of (or simplifies) external surge absorption circuit
- Built-in independent overcurrent and thermal protection circuit in each circuit
- Built-in protection against reverse connection of power supply
- $T_j = 150^\circ\text{C}$ guaranteed

Absolute Maximum Ratings

($T_a = 25^\circ\text{C}$)

Parameter	Symbol	Ratings	Unit	Conditions
Power supply voltage	V_B	-13 to +40	V	
Drive terminal applied voltage	V_D	-0.3 to V_B	V	
Input terminal voltage	V_{IN}	-0.3 to +7.0	V	
DIAG output applied voltage	V_{DIAG}	-0.3 to +7.0	V	
DIAG output source current	I_{DIAG}	-3	mA	
Voltage across power supply and output terminal	V_{B-O}	$V_B - 34$	V	
Voltage across power supply and drive terminal	V_{B-D}	-0.4	V	
Output current	I_O	1.5	A	
Output reverse current	I_O	-1.8	A	
Electrostatic resistance	E_S/A	± 250	V	$C = 200\text{pF}$, $R = 0\Omega$
Power Dissipation	P_D	4.8	W	Stand-alone without heatsink, all circuits operating
Junction temperature	T_j	-40 to +150	$^\circ\text{C}$	
Operating temperature	T_{OP}	-40 to +115	$^\circ\text{C}$	
Storage temperature	T_{stg}	-50 to +150	$^\circ\text{C}$	

External Dimensions (unit: mm)

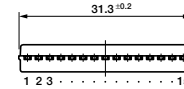
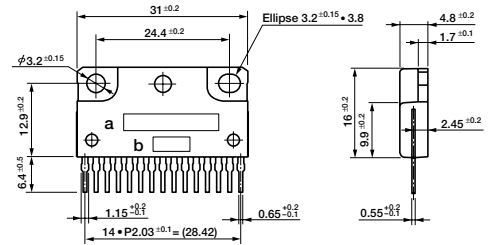

a: Part No.
b: Lot No.

Equivalent Circuit Diagram

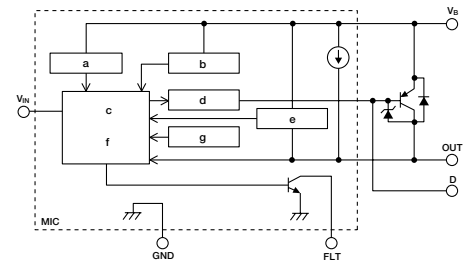

- a: Pre-regulator
- b: Overvoltage protection circuit
- c: Control circuit
- d: Driver circuit
- e: Overcurrent protection circuit
- f: Diagnostic circuit
- g: Thermal protection circuit

Electrical Characteristics

($V_{Bopr} = 14V$, $T_j = -40$ to $+150^\circ\text{C}$ unless otherwise specified)

Parameter	Symbol	Ratings			Unit	Conditions	
		min	typ	max			
Operating power supply voltage	V_{Bopr}	6.0		16	V		
Quiescent circuit current (per circuit)	I_q		0.8	1.6	mA	I_O output	
Circuit current (per circuit)	I_B		19.3		mA	$T_j = 25^\circ\text{C}$	
Threshold input voltage	V_{INth}	0.8		3.0	V		
Input voltage	Hi output	V_{IN}	3.7		V		
	Lo output	V_{IN}		1.5	V		
Input current	Hi output	I_{IN}		-1.0	mA	$V_{IN} = 5V$	
	Lo output	I_{IN}	100		μA	$V_{IN} = 0V$	
Saturation voltage of output transistor	$V_{CE(sat)}$			0.2	V	$I_O \leq 1.2A$, $V_{Bopr} = 6$ to $16V$	
	$V_{CE(sat)}$		1.0		V	$I_O \leq 1.5A$, $V_{Bopr} = 6$ to $16V$	
Output terminal sink current	$I_{O(off)}$		2.5	5	mA	$T_j = 25^\circ\text{C}$, $V_{CE0} = 14V$	
Surge clamp voltage	V_{B-O}		29	34	39	V	$T_j = 25^\circ\text{C}$, $I_C = 10\text{mA}$
			28	34	40	V	$I_C = 5\text{mA}$
Saturation voltage of DIAG output	V_{DL}			0.4	V	$I_{DGH} = -2\text{mA}$, $V_{Bopr} = 6$ to $16V$	
Leak current of DIAG output	I_{DGH}			-100	μA	$V_{CC} = 7V$	
Open load detection resistor	R_{open}	5.5			k Ω		
Overcurrent protection starting current	I_S	1.6			A	$V_O = V_{Bopr} - 1.5V$	
Thermal protection starting temperature	T_{TSD}				$^\circ\text{C}$	$V_{Bopr} \geq 6V$	
Output transfer time	T_{ON}			30	μs	$I_O = 1A$	
	T_{OFF}			100	μs	$I_O = 1A$	
DIAG output transfer time	T_{PLH}			30	μs	$I_O = 1A$	
	T_{PHL}			100	μs	$I_O = 1A$	
Minimum load inductance	L_O	1.0			mH		
Maximum ON duty	$D_{(ON)}$	0		60	%		

Note:

* The Zener diode has an energy capability of 200 mJ (single pulse).

* A start failure may occur if a short OFF signal of 10 ms or below is input in the V_{IN} terminal.

Standard Circuit Diagram

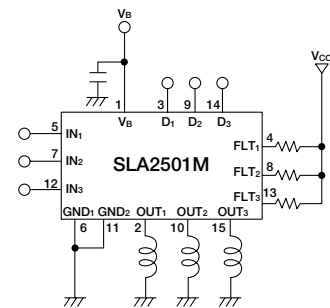

Diagnostic Function

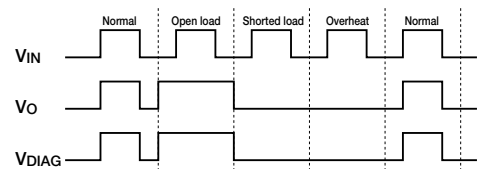

Electrical Characteristics

■ Quiescent Circuit Current (single circuit)

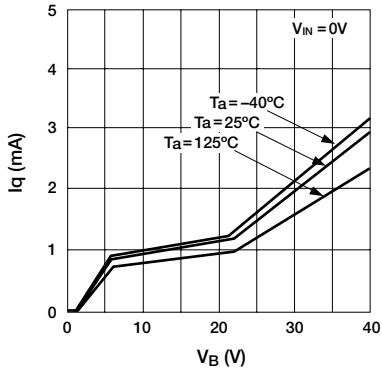

■ Circuit Current (single circuit)

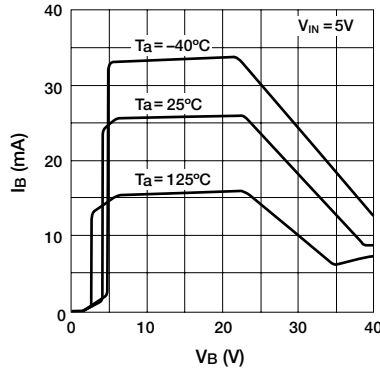

■ Saturation Voltage of Output Transistor

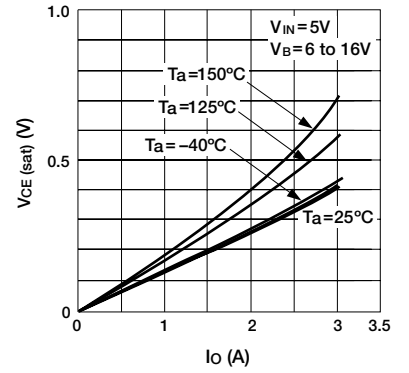

■ Overcurrent Protection Characteristics ($T_a = -40^\circ C$)

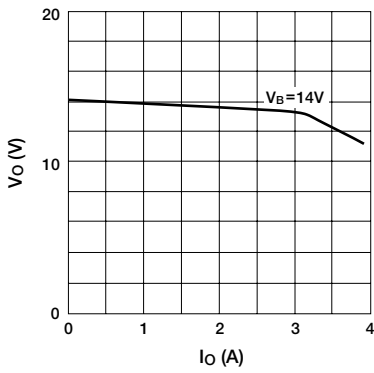

■ Overcurrent Protection Characteristics ($T_a = 25^\circ C$)

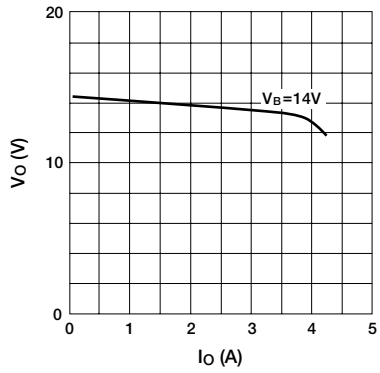

■ Overcurrent Protection Characteristics ($T_a = 125^\circ C$)

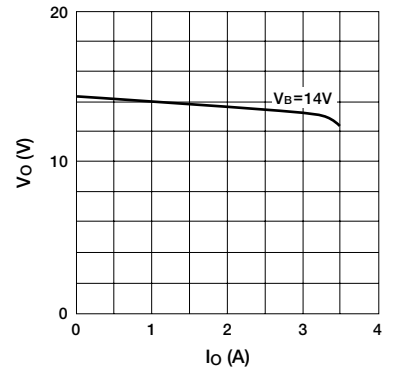

■ Threshold Input Voltage

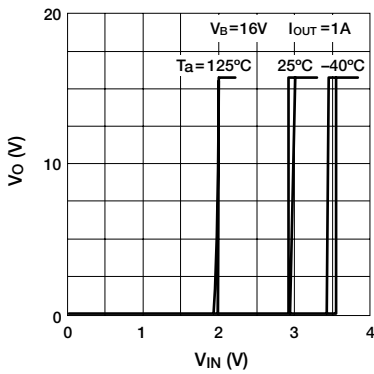

■ Input Current (Output ON)

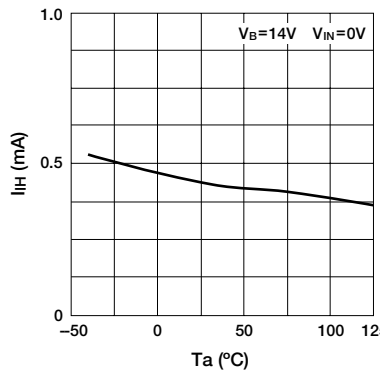

■ Input Current (Output OFF)

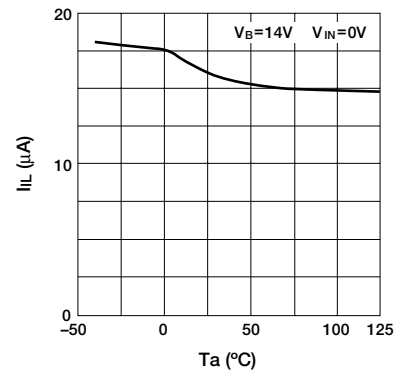

■ Saturation Voltage of DIAG Output

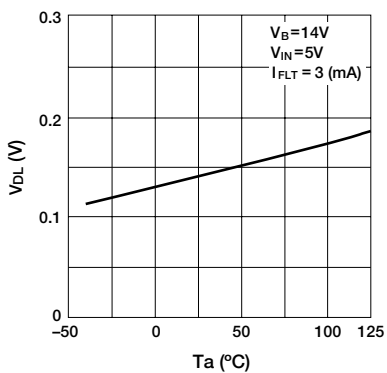

■ Output Reverse Current

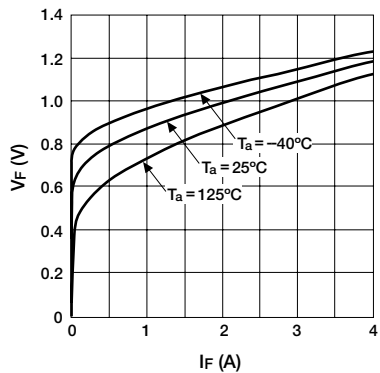

■ Thermal Protection

