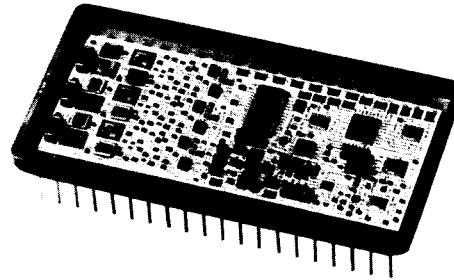

**Features**

- ✓ **Fully Protected 7 VA Output**  
(current limiting)  
(short circuit proof)  
(voltage feedback transients)  
(over-temperature)
- **BIT (Built-In-Test) Output**  
(over-current or temperature)  
(loss of reference or DC power)
- ✓ **1 Arc-minute Accuracy**
- ✓ **Output Remote Sensing**  
(for driving long load lines)
- **0.05% Maximum Scale Factor Variation**  
(L-L variation vs. angle)
- **Microprocessor Compatible**  
(8- and 16-Bit)
- **Double-Buffered Inputs**
- **11.8 V<sub>L-L</sub> Synchro Output**  
(S2 Grounded, 5VA option)
- ✓ **Standard Reference Voltages**  
(115, 26, 3.4 or adjustable)
- **TTL and CMOS compatible**
- **Hi-rel MIL-STD-883 processing available**

**ACTUAL SIZE****Applications**

Flight Simulation  
 Flight Instrumentation  
 Fire Control Systems  
 Position Control Systems  
 Remote Indicators  
 Radar and Navigation Systems

**Description**

Offering both 8- and 16-bit microprocessor compatibility, the **HDS2616** offers the highest drive capability of any hybrid digital-to-synchro converter available providing 7-VA output drive, 16-bit resolution and 1 arc-minute accuracy. The other outstanding features include double-buffered inputs, 0.05% vector accuracy, BIT (built-in test) and fully protected analog synchro outputs.

Packaged in a 40-pin triple DIP, the converter does not require a +5-V logic supply. The digital inputs are TTL and 5-V CMOS compatible. Internally derived logic thresholds are 0.8 V-dc for a logic "low" and 2.4 V-dc for a logic "high."

All data bits (B1 through B16) are actively pulled down to ground. If the converter requires less than 16-bit resolution, the unused data bit pins may be left unconnected. Control Signals LBE, HBE and LDC are actively pulled-up to logic "high" so that the **HDS2616** may be used in conventional

applications without any external components or additional connections.

The output power stage can be driven by a  $\pm 15$  V-dc power supply or pulsating supplies for higher efficiency. The output protection includes current limiting, short circuit and voltage feedback transients. For additional protection thermal cut-off protection can be enabled with a digital control bit.

Model **HDS2616** converters are available with angular accuracies of 1, 2 and 4 arc-minutes. These accuracies are guaranteed over the specified operating temperature range. In addition, output remote sensing is provided to reduce errors caused by long output lines and heavy loads. Matched thin-film resistors are used to scale the reference input as well as the synchro outputs to assure excellent performance over the entire operating temperature range. All gain resistors are actively laser trimmed to achieve precise performance.

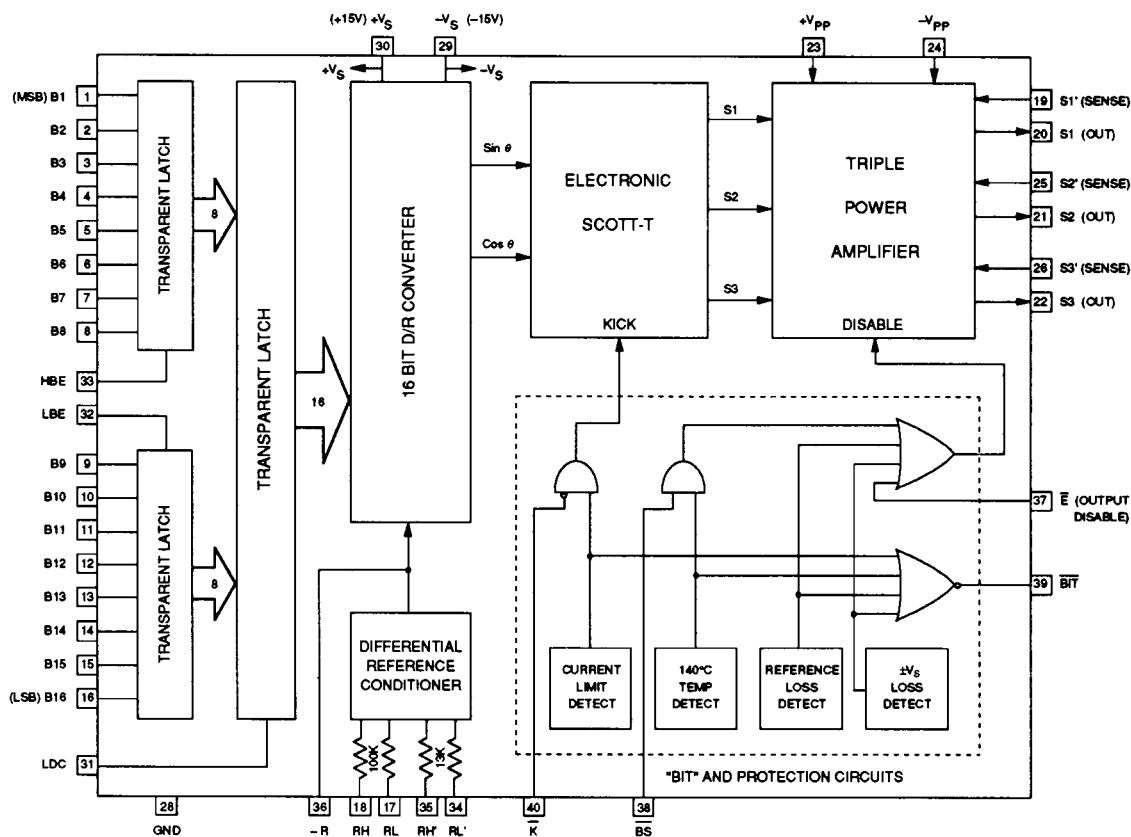

FIGURE 1 2616 Functional Block Diagram

Operation of the **HDS2616** is illustrated in the functional block diagram of Figure 1. The nominal synchro output level (L-L) is 11.8 V-rms. The "differential reference conditioner" can accept three standard Reference voltage levels (115, 26 or 3.4 V-rms), by appropriate pin connections at RH, RL, RH' and RL' (see Reference Level Adjustment). Additionally, the **Model 2616** can be resistor-programmed to accept any possible Reference input level. Since the synchro output voltage level (L-L) varies directly proportional to the applied reference input, resistor programming can be used to adjust the synchro output to any L-L level from 0 to 13 V-rms.

The 16-bit digital angle input (B1-B16) can be loaded into the **HDS2616** using a single 16-bit byte or two separate 8-bit bytes. When interfacing to an 8-bit data bus, latch enables HBE (high byte enable) and LBE (low byte enable) can be used to sequentially load two 8-bit bytes of data into the **2616**. Once the data is loaded into the first pair of registers, data can be transferred (in one 16 bit word) to the "16 Bit D/R converter" using the LDC (load converter) latch enable control input. This "Double Buffering" of the digital input is especially important in 8-bit microcomputer-based control systems because it eliminates angle output jitter during the multiplexing of the two 8-bit bytes, during which "false" 16-bit words are momentarily generated.

The "16 Bit D/R Converter" produces outputs which are proportional to the "Sin" and "Cos" of the digital angle input,

multiplied by the reference input (-R). The most significant digital input bit (B1) represents 180 degrees of angle. The least significant digital input bit (B16) represents 0.0055 degrees. The full scale digital input (all bits "on") is equivalent to 360 degrees minus 1 LSB (359.9945 degrees). With the nominal input reference voltage applied, the nominal level at the "test point" labeled (-R) is 2.27 V-rms.

The Sin and Cos outputs from the D/R converter is converted to a 3-wire synchro format using an "Electronic Scott-T." This output is then buffered using a precision "Triple Power Amplifier" which provides up to 7 VA output drive to the synchro load (680 mA-rms @ 11.8 V-rms L-L). The **Model 2616-X2X** option drives a synchro load with "S2" tied to system GND. In this case, the total output drive is limited to 5 VA.

Extensive BIT (built-in-test) and output protection circuits are incorporated into the **Model 2616**. A logic "0" is produced at the BIT output whenever an "over-current," "over-temperature," "loss of reference" or "loss of DC supply" is detected. In addition to active current limit and short circuit protection, the output will be put into a "high impedance" state during an "over-temperature," "loss of reference" or "loss of DC power" or by applying a logic "1" to the "output disable" (E). A logic "0" at Pin 38 (BS) can override the "over-temp" disable function. When driving "Torque Receiver" loads, pin 40 (K) can be tied to GND, which enables a "Kick" circuit to prevent potential false null "hang-ups."

## Pin Designations

**B1-B16** Parallel Input Data Bits –  
 B1 is MSB. Bit weight = 180 degrees  
 B16 is LSB. Bit weight = 0.0055 degrees

**HBE** High Byte Enable –  
 Logic "1" loads B1–B8 input data  
 Logic "0" holds B1–B8 input data

**LBE** Low Byte Enable –  
 Logic "1" loads B9–B16 input data  
 Logic "0" holds B9–B16 input data

**LDC** Load Converter –  
 Logic "1" loads B1–B16 data to D/R  
 Logic "0" holds B1–B16 data to D/R

$\bar{E}$  Analog Output Enable / Disable Control –  
 Logic "1" Disables Synchro Output  
 Logic "0" Enables Synchro Output

$\bar{K}$  Kick Enable / Disable Control –  
 Logic "1" Disables the "Kick" function  
 Logic "0" Enables the "Kick" function

$\bar{BS}$  Battle Short Temperature  $\bar{O}$ verride Control –  
 Logic "1" Enables Thermal Cut-off  
 Logic "0" Disables Thermal Cut-off

$\bar{BIT}$  Built-In-Test Output –  
 Logic "1" = No Fault Detected (Normal)  
 Logic "0" = Fault Detected

**-R (TP)** Analog Reference Output (test point) –  
 2.27 V-rms nominal

**GND** Power Supply Ground, Digital Ground

B1	1	40	$\bar{K}$
B2	2	39	$\bar{BIT}$
B3	3	38	BS
B4	4	37	$\bar{E}$
B5	5	36	-R
B6	6	35	RH'
B7	7	34	RL'
B8	8	33	HBE
B9	9	32	LBE
B10	10	31	LDC
B11	11	30	+VS
B12	12	29	-VS
B13	13	28	GND
B14	14	27	NC
B15	15	26	S3'
B16	16	25	S2'
RL	17	24	-Vpp
RH	18	23	+Vpp
S1'	19	22	S3
S1	20	21	S2

**FIGURE 2 HDS2616 Pin Assignments**

**+VS, -VS** Supply Voltages –  
 $\pm 15$  V-dc typical

**+Vpp, -Vpp** Power Amplifier Supply –  
 $\pm 15$  V-dc or "pulsating supply"  
 $\pm 23$  V-dc or "pulsating supply" (-2 model)

**RH, RL** Reference Voltage Input –  
**RH', RL'** Pin programmable for 3.4, 26 or 115 V-rms  
 (see text for connections)

**S1, S2, S3** Synchro Analog Outputs –

**S1', S2', S3'** Synchro Analog Sense Inputs –  
 (must be connected to outputs)

## Absolute Maximum Ratings

Reference Input .....	Twice Specified Voltage
Power Supply Voltages ( $\pm VS$ ) .....	$\pm 18$ V-dc
Power Supply Voltages ( $\pm Vpp$ ) .....	$\pm 25$ Vpeak
Digital Inputs .....	- 0.3 V-dc to +6.5 V-dc
Storage Temperature .....	- 65°C to +150°C

Although the digital inputs are CMOS protected, storage in conductive foam is recommended.

When installing or removing the converter from printed circuit boards or sockets, it is recommended that the power supply be turned off. Decoupling capacitors are recommended on the  $\pm VS$  and  $\pm Vpp$  supplies. A  $1\mu F$  tantalum capacitor in parallel with  $0.01\mu F$  ceramic capacitor should be mounted as close to the supply pins as possible.

### CAUTION:

Reversal of  $+VS$  and  $-VS$  or reversal of  $+Vpp$  and  $-Vpp$  power supply connections will result in permanent damage to the converter.

For applications requiring high output drive, an adequate heat sink must be provided to keep the case temperature below the maximum operating temperature. The **HDS2616** converter has been designed with a flat metal base to allow the addition of heat sinking material.

## Specifications

PARAMETER	VALUE	REMARKS	TEST LEVEL
<b>Digital Angular Resolution</b>			
	16-bits (0.33 arc-minutes)	MSB = 180° LSB = 0.0055°	Note 2
<b>Accuracy</b>			
No-Load	± 4.0 arc-minutes (option S) ± 2.0 arc-minutes (option H) ± 1.0 arc-minutes (option V)	Accuracy applies over the full operating temperature and DC supply range. Reference frequency = 400 Hz ±10% (add ±1 arc-min. for Fref = DC to 1 KHz).	Note 1
Additional Error vs. Load	± 0.5 arc-minutes/VA load		
<b>Reference Input</b>			
Voltage			Note 2
Using pin programming	3.4 V-rms ± 10% 26.0 V-rms ± 10% 115.0 V-rms ± 10%	RH' and RL' as Input, RH and RL Open RH and RL as Input, RH' and RL' Open RH and RL as Input, RH' and RL' GND	
Using 2 external resistors	3.4 V-rms to 200 V-rms	See "Reference Level Adjustment"	
Frequency Range	DC – 1000 Hz	Best accuracy @ 400 Hz	
Input Impedance			Note 2
RH - RL (differential) (single ended)	200,000 ohms ± 0.5% 100,000 ohms ± 0.5%	±1.0% over temperature ±1.0% over temperature	
RH' - RL' (differential) (single ended)	26,154 ohms ± 0.5% 13,077 ohms ± 0.5%	±1.0% over temperature ±1.0% over temperature	
Common Mode Voltage Range		Using internal resistors (pin programming)	Note 3
3.4 V-rms (RH', RL) input 26.0 V-rms (RH, RL) input 115.0 V-rms (RH, RL) input	± 10 Volts Peak ± 80 Volts Peak ± 200 Volts Peak	RH , RL Open RH' , RL' Open RH' , RL' GND	
Common Mode Rejection Ratio	50 db minimum	Using internal resistors (pin programming)	Note 3
<b>Digital Inputs</b>		Transient-protected CMOS	
Logic "0" level Logic "1" level	- 0.3 to 0.8 V-dc 2.4 to 5.5 V-dc	( $\bar{K}$ input logic "1" = 3.5 V-dc min.)	Note 2 Note 2
Input Current Data bits B1-B16, $\overline{BS}$ , $\overline{EN}$ HBE, LBE, LDC, $\bar{K}$	15 $\mu$ A typical (30 $\mu$ A max.), - 15 $\mu$ A typical (-30 $\mu$ A max.),	Pull down to GND Pull up to internal +5 V-dc	Note 2 Note 2
Angle Data Bit Coding	Natural Binary Angle Positive Logic	Bit 1 is MSB (180 degrees) Bit 16 is LSB (0.0055 degrees)	Note 3
Power Amp Disable Control ( $\bar{E}$ )	Logic "1" disables synchro out		Note 1
Thermal Cut-Off Override ( $\overline{BS}$ )	Logic "0" disables Cut-off	"BIT" will still respond to "over-temp" condition	Note 2
"Kick" Circuit Enable ( $\bar{K}$ )	Logic "0" enables "Kick" circuit	Used when driving Torque Receivers (TRs)	Note 1
<b>Register Controls</b>		Active-high transparent latches	
HBE (High Byte Enable)	Logic "1" loads B1 – B8 data Logic "0" holds B1 – B8 data		Note 1
LBE (Low Byte Enable)	Logic "1" loads B9 – B16 data Logic "0" holds B9 – B16 data		Note 1
LDC (Load Converter)	Logic "1" loads B1 – B16 to D/R Logic "0" holds B1 – B16 to D/R	Data present @ output of HBE & LBE registers Data present @ output of HBE & LBE registers	Note 1
Timing (HBE, LBE, LDC)			
Enable Pulse Width Data Set-up Time Data Hold Time	400 ns minimum 200 ns minimum 100 ns minimum	For guaranteed data transfer Data stable before HBE, LBE or LDC low-to-high transition Data stable after HBE, LBE or LDC high-to-low transition	Note 3 Note 3 Note 3
<b>BIT Output (Built-In-Test)</b>		Active "low" output	
Logic "0" Logic "1"	- 0.3 to 0.8 V-dc 3.0 to 5.5 V-dc	Fault Detected For no Fault Detected (Normal)	Note 1
Output Current - Logic "0" - Logic "1"	+ 1.6 mA min. @ 0.4 V-dc - 0.4 mA min. @ 3.0 V-dc	(Internal 3.9 K pull-up to +5 V-dc.)	Note 2

PARAMETER	VALUE	REMARKS	TEST LEVEL
<b>Synchro Analog Outputs</b>			
Voltages (Line-to-Line)	11.8 V-rms $\pm 0.5\%$	For nominal reference voltages. The outputs vary in direct proportion to the reference amplitude	Note 1
Radius Accuracy	$\pm 0.05\%$ maximum	Scale factor variation with angle	Note 2
Drive Capability	7 VA minimum (option 3) 5 VA minimum (option 2)	GND is used for "S2" output (option 2)	Note 1
Output Drive Current 7 VA model	685 mA-rms minimum 969 mA-peak minimum	Option 3 (7VA limit)	Note 1
5 VA model	490 mA-rms minimum 692 mA peak minimum	Option 2 (5 VA limit)	Note 1
Synchro Load Impedance 7 VA model (minimum) 5 VA model (minimum)	ZSO > 15 ohms ZSO > 21 ohms	Option 3 (7 VA limit) Option 2 (5 VA limit)	Note 1 Note 1
Load Regulation	0.5% maximum	From no-load to full-load (@ sense points)	Note 2
Output DC Offset	$\pm 15$ mV-dc maximum	Any line to GND	Note 2
Phase Shift	Less than 2 degrees	Reference to Output @ 400 Hz	Note 3
Output Setting Time	40 $\mu$ s maximum	For any digital step change	Note 3
Output Current Limit 7 VA model 5 VA model	1.2 amps peak nominal 0.8 amps peak nominal	(Short circuit proof) Option 3 Option 2	Note 2
<b>Power Supply</b>			
+V <sub>S</sub> and -V <sub>S</sub> Supply Voltage Range Current	14 to 16 V-dc (15 V-dc typ.) 25 mA-dc maximum (no load)	Nominal Operating Range (30 mA-dc maximum @ full load)	Note 3 Note 1
+V <sub>pp</sub> and -V <sub>pp</sub> Supply Voltage Range Current (max) No-Load Average Current/VA load Peak Current/VA load Short Circuit	<u>7 VA Model</u> 14-20 V-dc  20 mA 100 mA/VA 150 mA/VA 1.5 Amps max.	<u>5 VA Model</u> 21-25 V-dc  20 mA 90 mA/VA 150 mA/VA 2.0 Amps max.	Must be > 3.5 V-dc above output level  Note 3  Note 1 Note 1 Note 2 Note 2
<b>Thermal Characteristics</b>			
Power Dissipation (Nominal) No-Load Power Dissipation/VA load Resistive Load Inductive Load Any Load with "Pulse Supply"	<u>7 VA Model</u> 0.7 watts  1.9 watts/VA 2.9 watts/VA 1.5 watts/VA	<u>5 VA Model</u> 0.8 watts  2.9 watts/VA 3.9 watts/VA 2.0 watts/VA	Values are "nominal" for typical conditions  (Add "No-Load" for Total Power Dissipation) V <sub>pp</sub> = DC supply V <sub>pp</sub> = DC supply V <sub>pp</sub> = "pulse supply"
Thermal Resistance Junction to Case (Nominal) Case to Ambient (Nominal)	2.1 deg. C / watt of total package diss. 15.0 deg. C / watt of total package diss.	(Output transistor junction) (Max. junction dissipation is approximately 25% of total) (Free air - no heat sink)	Note 3
<b>Physical Characteristics</b>			
Type	40 PIN Triple DIP		
Size	2.14 x 1.14 x 0.18 inch. (54.4 x 29 x 4.6 mm)		Note 3
Weight	0.9 oz. (26g) max.		Note 3

NOTE 1. Compliance of each component to this specification is 100% guaranteed by Natel. To assure compliance, this key parameter is 100% tested.

NOTE 2. Compliance of each component to this specification is 100% guaranteed by Natel. To assure compliance, AQL levels are verified using a lot sample level in the range of one to five percent.

NOTE 3. Compliance of each component to this specification is 100% guaranteed by Natel. To assure compliance, AQL levels are verified using a lot sample level of less than one percent. Note 3 parameters are maximum design limits.

If your application requires 100% testing of any additional parameters of this specification or requires non-standard input or output characteristics, please contact a Natel Applications Engineer or the Sales Department.

## Digital Interface

The double buffered input registers of the **HDS2616** offer the user an easily implemented interface with 8- or 16-bit microprocessor data buses. For applications not involving a microprocessor, independently controlled 8-bit latching registers give the user the flexibility of designing his own

interface system. Provision has also been made for asynchronous data inputs through the use of the LDC control function. Asynchronous data inputs up to 16-bits can be accommodated. Memory mapped I/O with an 8080 microprocessor is described in our data sheet **HDSC2016**.

## Continuous Operation

Asynchronous converter operation, without timing controls, is shown in Figure 3. Inputs LBE, HBE and LDC have internal pull-up circuitry, permitting these pins to be left open. The parallel information at the data inputs B1-B16 is continuously converted to 3 wire synchro format at the analog outputs. For applications requiring less than 16-bit resolution, unused pins can be left open or tied to GND. Internal pull-down circuitry applies a logic "0" to unconnected data inputs B1-B16.

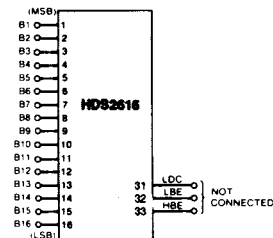

FIGURE 3 Digital Connection for Continuous Operation

## Two-Byte Loading

The circuit configuration for two-byte loading of angular data from a data bus is shown in Figure 4. As shown in Figure 5 timing diagram, the 8 LSBs (B9-B16) are transferred to the low-byte input register when LBE is a logic "1." LBE can be "High" when data bits are changing, but must remain "High" for a minimum of 400 nsec after the data is stable. Data should be held for 100 nsec (data hold time) after LBE goes "Low." Bits B1-B8 are transferred to the high-byte input register when HBE is a logic "1."

The timing requirements are the same as those for LBE. Data is transferred from the two input registers to the holding register when LDC (load converter) is at logic "1." If LDC is at logic "0," the contents of the holding register is latched and remain at their previous values unaffected by changes at the data inputs or input registers.

Note that LBE, HBE and LDC are level actuated functions.

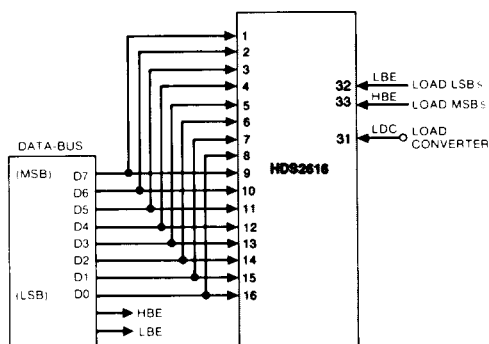

FIGURE 4 Digital Connections for Two-Byte Loading

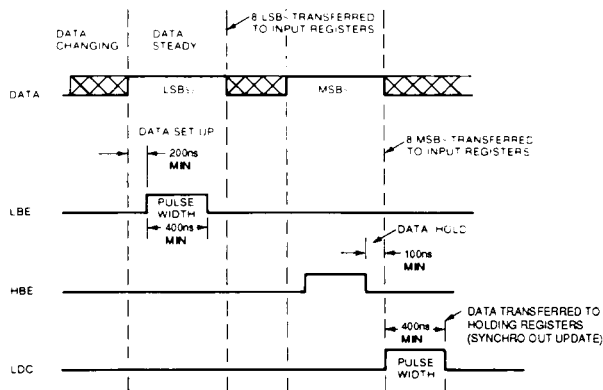

FIGURE 5 Two-Byte Loading

## Single-Byte Loading

Single 16-bit byte loading is illustrated in Figure 6. As shown in the timing diagram (Figure 7), 200 nsec after the data is stable, the input angular information is transferred to the

holding register when LDC is at a logic "1." LDC is a level-actuated function and must remain high for the times specified in the timing diagram.

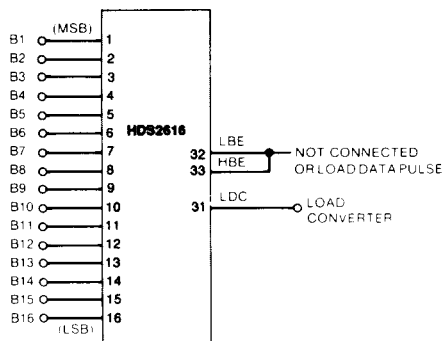

FIGURE 6 Digital Connections for One Byte (16 bits) Loading

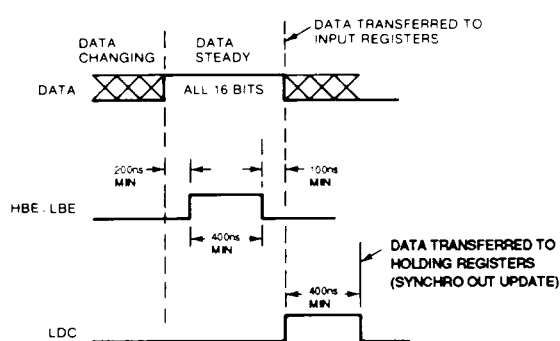

FIGURE 7 Single-Byte Loading

## Reference Level Adjustment

Operation of the HDS2616 is very similar to that of a multiplying digital-to-analog converter. The outputs are directly proportional to and have the same waveform as the reference voltage. Any distortion or harmonics present at the reference will appear at the output lines.

Internal resistors permit pin programming for three standard reference voltages with the normal analog output 11.8 V-rms L-L. The connections for the three reference voltages – 3.4 V-rms, 26 V-rms and 115 V-rms are shown in Figure 8. Proportionally higher or lower voltages will be obtained for analog outputs when higher or lower reference voltages are used.

To obtain nominal analog output with non-standard reference voltages, two external resistors are required. The input resistance for RH and RL is 100 kΩ. RH' and RL' are each 13.077 kΩ. The circuit configuration for reference voltages other than nominal is shown in Figures 9 through Figure 11.

For high reference voltages (26 to 115 V-rms), the resistor values for R1 might become too large to be practical. In those situations the external resistor should be connected as shown in Figure 10.

For reference voltages greater than 115 V-rms the external resistors should be connected as shown in Figure 11.

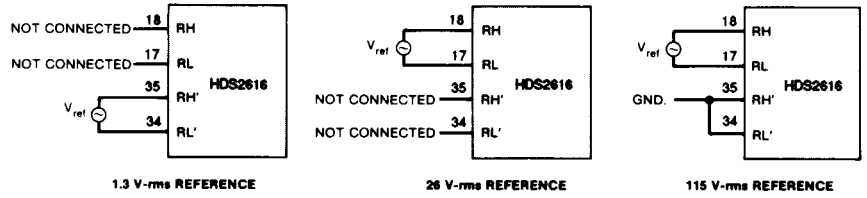

FIGURE 8

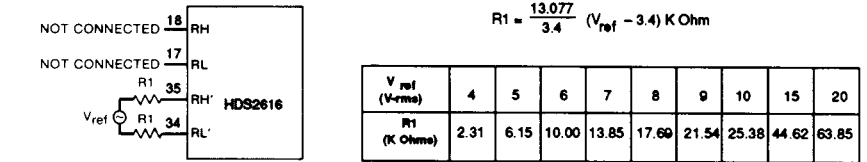

FIGURE 9  $V_{ref} = 3.4 \text{ V-rms to } 26 \text{ V-rms}$

$$R1 = \frac{13.077}{3.4} (V_{ref} - 3.4) \text{ K Ohm}$$

$V_{ref}$ (V-rms)	4	5	6	7	8	9	10	15	20
R1 (K Ohms)	2.31	6.15	10.00	13.85	17.69	21.54	25.38	44.62	63.85

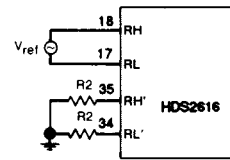

FIGURE 10  $V_{ref} = 26 \text{ V-rms to } 115 \text{ V-rms}$

$$R2 = \frac{241.546}{V_{ref} - 26} - 2.714 \text{ K Ohm}$$

$V_{ref}$ (V-rms)	30	40	50	60	70	80	90	100	110
R2 (K Ohms)	57.67	14.54	7.35	4.39	2.78	1.76	1.06	0.55	0.16

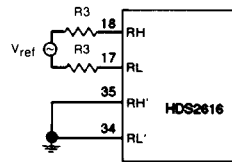

FIGURE 11  $V_{ref}$  Greater than 115 V-rms

$$R3 = 0.79815 V_{ref} - 91.787 \text{ K Ohm}$$

$V_{ref}$ (V-rms)	125	130	140	150	160	170	180	190	200
R3 (K Ohms)	7.98	11.97	19.95	27.94	35.92	43.90	51.88	59.86	67.84

## Synchro Connections – Output Phasing and Gain

The connections for the synchro outputs, along with a diagram of L-L voltage and phase relationship is shown in Figure 12. For standard reference voltages, the gain of the converter is factory set to provide a maximum L-L output level of 11.8 V-rms  $\pm 0.5\%$ . If other L-L voltages are needed (0 to 13 V-rms), two external resistors can be used (as shown in the "reference level adjustment") to adjust the "gain" of the converter for the desired output.

The output "sense" lines (S1', S2', and S3') must be connected to each output line, respectively as shown. The 5 VA "S2 GND" option will operate properly with up to a 1 V-rms GND differential between the converter GND and Synchro GND (@ S2').

For stable operation when driving heavy loads, power supply decoupling capacitors are recommended. As a minimum:

For  $\pm V_S$ :  $1\mu\text{F}$  Tantalum +  $0.01\mu\text{F}$  ceramic  
 For  $\pm V_{pp}$ :  $10\mu\text{F}$  Tantalum +  $0.01\mu\text{F}$  ceramic

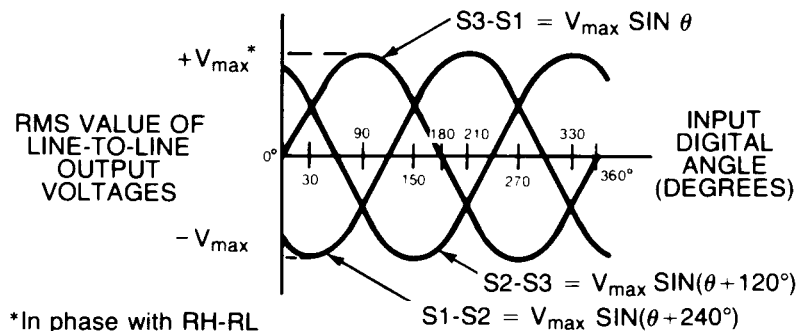
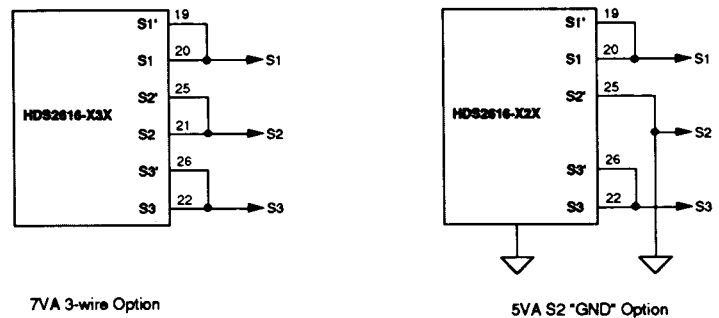
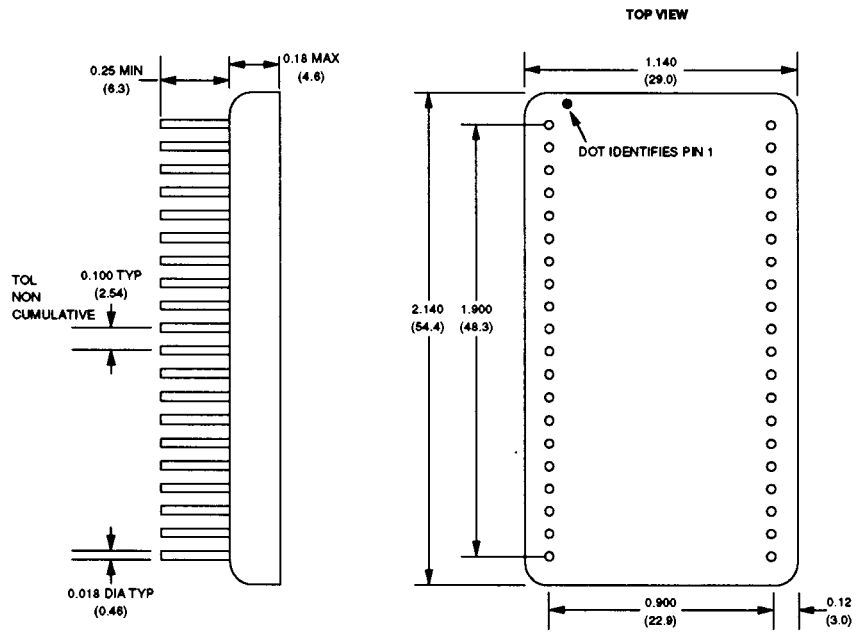

FIGURE 12 Synchro Outputs



**TOLERANCES:**  
 .XX = ±0.01 (±0.25)  
 .XXX = ±0.005 (±0.13)

- NOTES:**
1. PINS ARE KOVAR WITH GOLD PLATING: (50μ INCH MIN).
  2. PACKAGE IS KOVAR WITH ELECTROLESS NICKEL PLATING.
  3. DIMENSIONS SHOWN IN INCHES AND (MM).

**MECHANICAL OUTLINE (40 PIN TRIPLE DIP)**

**Ordering Information**

<b>HDS2616</b>	<b>—</b>	<b>T</b>	<b>O</b>	<b>A</b>
<b>Temperature Range</b>				<b>Accuracy</b>
1 = 0°C to +70°C				S = ±4.0 arc-minutes
2 = -25°C to +85°C				H = ±2.0 arc-minutes
3 = -55°C to +125°C				V = ±1.0 arc-minutes
				<b>Output Option</b>
				2 = 2 line 11.8 V-rms (5 VA) (GND = S2 output)
				3 = 3 line 11.8 V-rms (7 VA)

**MIL-STD-883 COMPLIANT HYBRIDS AVAILABLE**  
 Contact Natel Engineering for Delivery

**Other products available from NATEL**

- **3 arc-second accurate**, Programmable Dynamic Angle Simulator that includes 4 Related Instruments and is totally A.T.E. Programmable (L200).
- Hybrid (36-pin DDIP size) Synchro(Resolver)-to-Digital converters that operate from a **single +5V power supply** and offer excellent features such as BIT, AGC, low power dissipation and more (Models 1006, 1056, 1046 and 1044).
- 1.3 arc-minute accuracy, high power, Digital-to-Synchro converters that **do not require any DC power supplies** (Models 5031 and 5131).
- 1-inch square, single +5V powered, 16-bit R/D converter with built-in **Reference Oscillator**. (HRD1416)
- **2-channel** Digital-to-Sin/Cos Converter in a single 36-pin hybrid (HDSC2036).
- **2-speed**, 22-Bit Synchro(Resolver)-to-Digital Converter, 0.0004° accuracy in a single 40-pin TDIP (HRD/HSD1626).
- **3-channel** Resolver-to-Digital Converter in a single 40-pin TDIP (HRD1346).
- Resolver Control Differential Transmitter in a single 36-pin package (HCDX3106).

A wide range of applications assistance is available from Natel. Application notes can be requested when available . . . and Natel's applications engineers are at your disposal for solving specific problems.

**TEL: (805) 581-3950**

**NATEL ENGINEERING CO., INC.**

4550 RUNWAY STREET • SIMI VALLEY, CA 93063-3493  
 TWX: (910) 494-1959 FAX: (805) 584-4357

Specifications subject to change without notice.  
 Printed in USA Copyright © 1992 NATEL Engineering Co., Inc.

8  
 037296 ✓ R