

SYNCHRO/RESOLVER/INDUCTOSYN REFERENCE OSCILLATOR

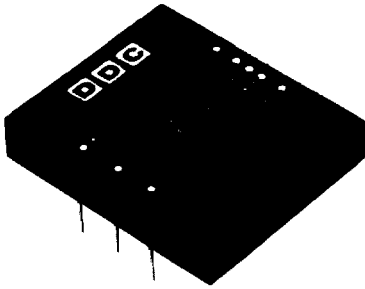

FEATURES

- *DRIVES UP TO 6 RESOLVERS, SYNCHROS OR INDUCTOSYNS*
- *2.5 KHz OR 10 KHz FOR HIGH SPEED APPLICATIONS*
- *11.8V, 4.4V OR 2.0V OUTPUT*
- *FULLY PROTECTED OUTPUT*
- *15 VDC OPERATION*
- *NO TRIMS OR ADJUSTMENTS*

DESCRIPTION

The REF-15001 Series provides reference excitation for synchros, resolvers and Inductosyns in systems where an AC reference is not readily available. Pin programmable for three different voltage levels, 11.8V, 4.4V, and 2.0V, the unit can be used with a wide variety of standard synchros, resolvers or Inductosyns. The output is fully protected against over current, short circuits and voltage transients. With a choice of 2.5 KHz

or 10 KHz frequencies, the REF-15001 Series can be used in high speed servo systems requiring good dynamic response. Able to drive up to 6 synchro/resolver/Inductosyn and converter pairs, the unit is ideally suited to computer controlled servos and programmable controllers found in robotics, machine control, and motor control applications.

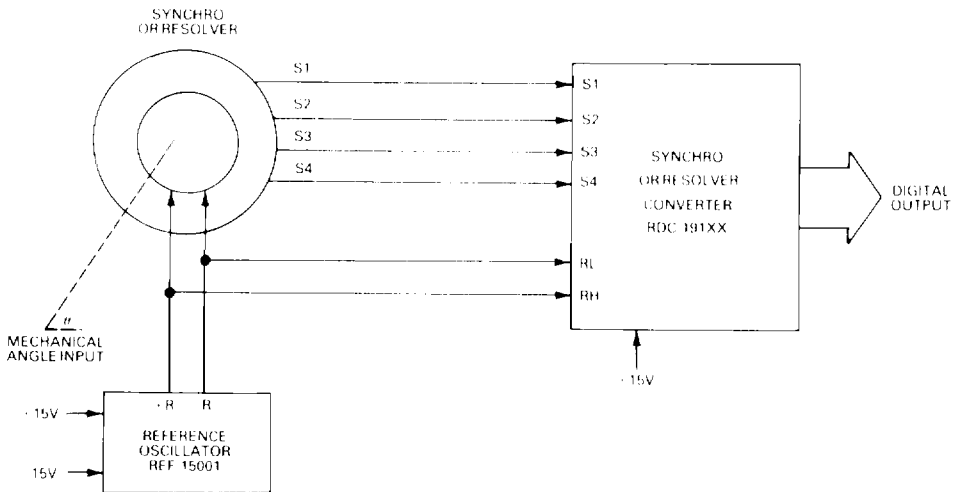

FIGURE 1. BLOCK DIAGRAM

SPECIFICATIONS Apply over temperature and power supply ranges	
PARAMETER	VALUE
FREQUENCY REF-15001 REF-15002	2.5 KHz $\pm 10\%$ 10 KHz $\pm 10\%$
OUTPUT Voltage +R to -R +R to -GND (4.4 tied to +R) +R to -GND (2.0 tied to +R) DC Offset Capacitive Load Current Protection Quadrature Reference	11.8V rms $\pm 10\%$ 4.4V rms $\pm 10\%$ 2.0V rms $\pm 10\%$ ± 20 mV, max 0.1 μ F, max 110 mA, max Overcurrent, short circuit and voltage transient 12V rms $\pm 10\%$ at 1.0 mA
POWER SUPPLIES Voltage Current No Load Full Load Maximum Voltage (without damage)	± 15 VDC, $\pm 5\%$ 50 mA 160 mA ± 18 VDC
TEMPERATURE RANGE Operating Storage	0°C to -70°C -55°C to +125°C
PHYSICAL CHARACTERISTICS Size Weight	1.52 x 1.78 x 0.35 in. (39 x 45 x 9 mm) 0.9 oz. (25.5 gm)

TECHNICAL INFORMATION SYNCHRO/RESOLVER APPLICATIONS

The REF-15001 is designed for use with most common synchros, resolvers and converters operating with 11.8V, 4.4V, or 2.0V references at 2500 Hz. It can drive up to 110 mA. It is not intended for use in torque repeater/indicator applications.

A typical interconnection is shown in Figure 1. No trim or adjustments are required. Output voltage levels are pin programmed as specified in Table 1.

REFERENCE OUTPUT VOLTAGE	AT PINS	JUMPER CONNECTIONS
11.8V rms 4.4V rms 2.0V rms*	+R to -R +R to GND +R to GND	None Pin 4.4 to +R Pin 2.0 to +R

*Recommended for Inductosyn Applications

The 11.8V rms output is intended for use with resolvers having a 1:1 transformation ratio and operating into a converter requiring a 11.8V L-L input. The 4.4V rms output is intended for use with synchros or resolvers having a transformation ratio of 26:11.8 and operating into a direct input converter requiring 2.0V L-L input. The 2.0V rms output is for use with resolvers having a 1:1 transformation ratio and operating into a converter requiring a 2.0V L-L input.

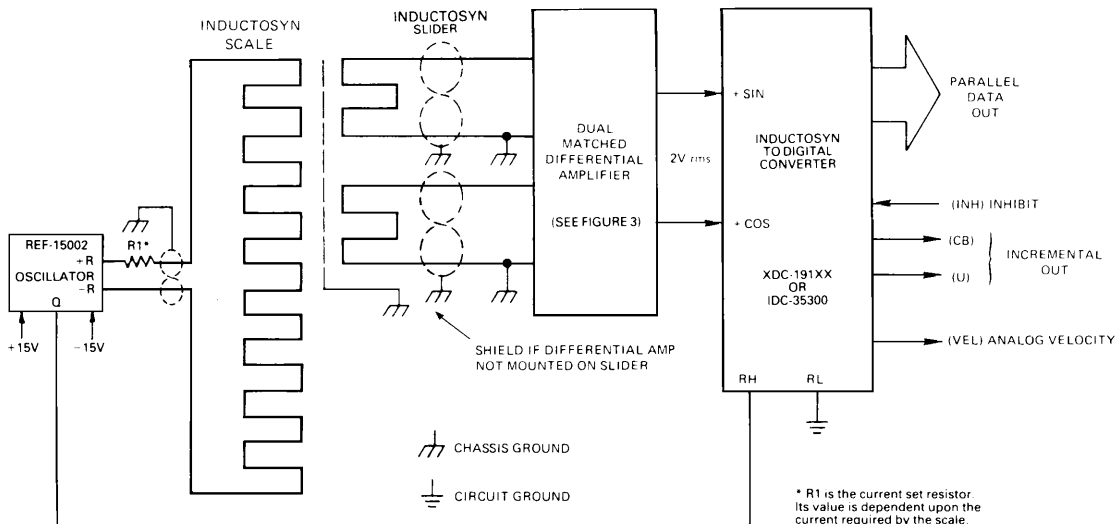
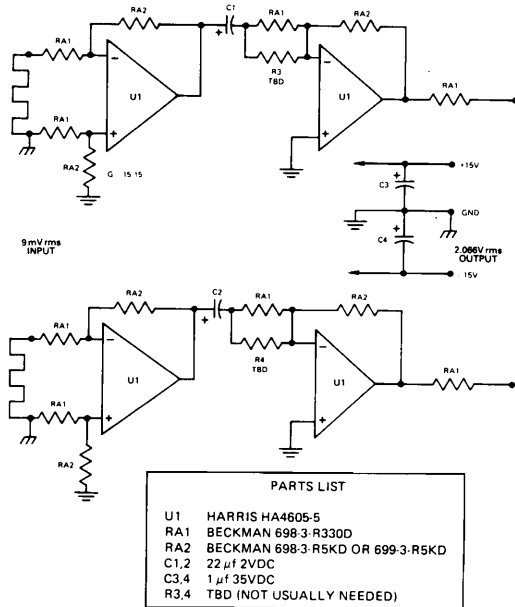

FIGURE 2. TYPICAL INDUCTOSYN CONNECTION.

INDUCTOSYN APPLICATIONS

The REF-15002 can drive up to 110 mA and is designed for use with Inductosyns operating at 10 KHz. It is recommended that the unit be suitably programmed as indicated in Table 1 for the correct current level required for the specific Inductosyn. A typical interconnection is shown in Figure 2. No trims or adjustments are required on the converter. Note the Inductosyn is driven from the +R and -R pins while the converter reference is taken from the Q pin. This is a 12V rms, 1 mA output in quadrature with +R and -R and is correctly compensated for the phase shift of Inductosyns. Figure 3 illustrates the circuit needed between the inductosyn slider and the converter.



- NOTES: 1. For other input levels select RA1 and RA2 as required. Standard values are: 100, 200, 330, 470, 500, 1K, 2K, 2.2K, 4.7K, 5K, 10K, 15K, and 20K Ω .
 2. For lower input levels use Harris HA-4625-5

FIGURE 3. DUAL MATCHED DIFFERENTIAL AMPLIFIER

MECHANICAL OUTLINE

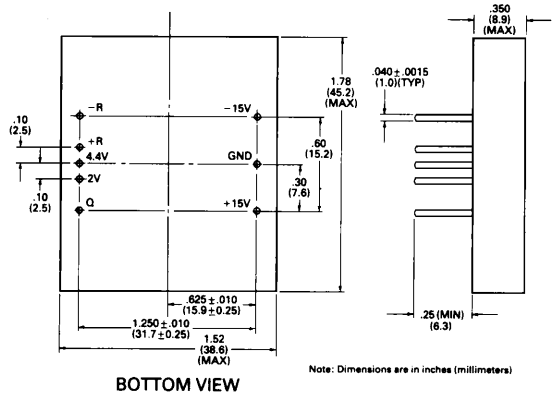

ORDERING INFORMATION

REF-1500X-300

Temperature Range
 (operating):
 3=0°C to +70°C

Options:
 1=2.5 KHz
 2=10 KHz

The information provided in this Data Sheet is believed to be accurate; however, no responsibility is assumed by ILC Data Device Corporation for its use, and no license or rights are granted by implication or otherwise in connection therewith. Specifications are subject to change without notice.