

The PJ393 is dual independent precision voltage comparators capable of single- or split-supply operation. specifications as low as 2.0 mV make this device an excellent ground level with single-supply operation. Input offset-voltage selection for many applications in consumer automotive, and It is designed to permit a common mode range-to- industrial electronics.

FEATURES

- Output voltage compatible with DTL, ECL, TTL, MOS and CMOS Logic Levels
- Low input bias current -25 nA
- Low input offset current -5.0 nA
- Low input offset voltage --5.0 mV(max)
- Input common mode range to ground level
- Differential Input voltage range equal to power supply voltage
- Very low current drain independent of supply voltage - 0.4 mA
- Wide single-supply range - 2.0 Vdc to 36 Vdc
- Split-supply range - ± 1.0 Vdc to ± 18 Vdc

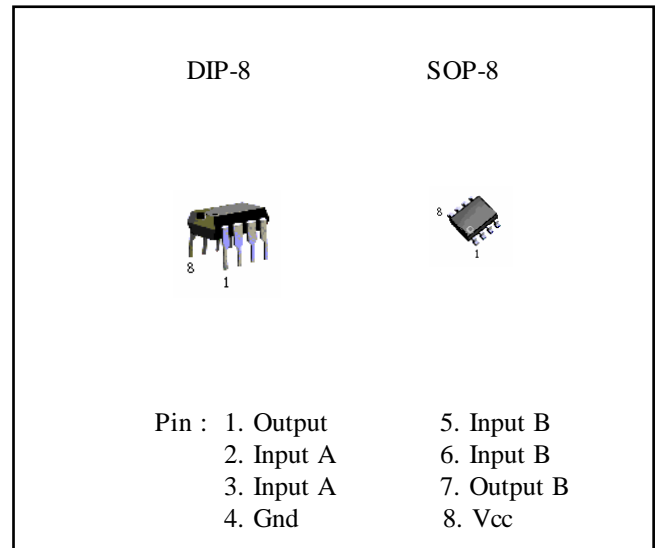

ORDERING INFORMATION

| Device | Operating Temperature | Package |
|---------|-----------------------|---------|
| PJ393CD | -20°C +85°C | DIP-8 |
| PJ393CS | | SOP-8 |

MAXIMUM RATINGS

| Rating | Symbol | Value | Unit |
|--|-------------------|-----------------|-------|
| Power Supply Voltage | V_{CC} | +36 or ± 18 | Vdc |
| Input Differential Voltage Range | V_{IDR} | 36 | Vdc |
| Input Common Mode Voltage Range | V_{ICR} | -0.3 to 36 | Vdc |
| Input Current (2) ($V_{in} -0.3$ Vdc) | I_{in} | 50 | mA |
| Output Short Circuit Duration | I_{SC} | Continuous | mA |
| Output Sink Current (1) | I_{sink} | 20 | mA |
| Power Dissipation@ $T_A=25^\circ C$ Plastic DIP Derate above 25°C | P_D | 570 | mW |
| | $1/R_{\theta JA}$ | 5.7 | mW/°C |
| Maximum Operating Junction Temperature | $T_{J(max)}$ | 125 | °C |
| PJ393 | T_{stg} | -65 to 150 | °C |

Dual Voltage Comparator

ELECTRICAL CHARACTERISTICS

($V_{CC} = 50\text{Vdc}$, $0^\circ\text{C} \leq T_A \leq 70^\circ\text{C}$ unless otherwise stated)

| Characteristics | Symbol | PJ393 | | | Unit |
|--|------------|----------|-----------------|------------------------------|---------------|
| | | Min | Typ | Max | |
| Input Offset Voltage (3) $T_A = 25^\circ\text{C}$ $-20^\circ\text{C} \leq T_A \leq 85^\circ\text{C}$ | V_{IO} | -- -- | ± 1.0 -- | ± 5.0 9.0 | mV |
| Input Offset Current $T_A = 25^\circ\text{C}$ $-20^\circ\text{C} \leq T_A \leq 85^\circ\text{C}$ | I_{IO} | -- -- | ± 5.0 -- | ± 50 ± 150 | nA |
| Input Offset Current (4) $T_A = 25^\circ\text{C}$ $-20^\circ\text{C} \leq T_A \leq 85^\circ\text{C}$ | I_{IB} | -- -- | 25 -- | 250 400 | nA |
| Input Common Mode Voltage Range (4) $T_A = 25^\circ\text{C}$ $-20^\circ\text{C} \leq T_A \leq 85^\circ\text{C}$ | V_{ICR} | 0 0 | -- -- | $V_{CC}-1.5$ $V_{CC}-2.0$ | Volts |
| Voltage Gain $R_L \geq 15\text{K}$, $V_{CC} = 15\text{Vdc}$ $T_A = 25^\circ\text{C}$ | A_{VOL} | 50 | 200 | -- | V/mV |
| Large Signal Response Time $V_{in} = \text{TTL Logic Swing}$ $V_{ref} = 1.4\text{Vdc}$ $V_{RL} = 5.0\text{Vdc}$, $R_L = 5.1\text{K}\Omega$ $T_A = 25^\circ\text{C}$ | -- | -- | 300 | -- | ns |
| Response Time (6) $V_{RL} = 5.0\text{Vdc}$, $R_K = 5.1\text{K}\Omega$ $T_A = 25^\circ\text{C}$ | t_{TLH} | -- | 1.3 | -- | μs |
| Input Differential Voltage (7) All $V_{in} \geq \text{Gnd}$ or $V\text{-Supply}$ (if used) | V_{ID} | -- | -- | V_{CC} | V |
| Output Sink Current $V_{in-} \geq 1.0\text{Vdc}$, $V_{in+} = 0\text{Vdc}$ $V_O \leq 15\text{Vdc}$, $T_A = 25^\circ\text{C}$ | I_{sink} | 60 | 16 | -- | mA |
| Output Saturation Voltage $V_{in-} \geq 1.0\text{Vdc}$, $V_{in+} = 0$ $I_{sink} \leq 4.0\text{mA}$, $T_A = 25^\circ\text{C}$ $-20^\circ\text{C} \leq T_A \leq 85^\circ\text{C}$ | V_{OL} | -- -- | 150 -- | 400 700 | mV |
| Output Leakage Current $V_{in-} = 0\text{V}$, $V_{in+} \geq 1.0\text{Vdc}$ $V_P = 50\text{Vdc}$, $T_A = 25^\circ\text{C}$ $V_{in-} = 0\text{V}$, $V_{in+} \geq 1.0\text{Vdc}$ $V_O = 30\text{Vdc}$, $-20^\circ\text{C} \leq T_A \leq 85^\circ\text{C}$ | I_{OL} | -- -- | 0.1 -- | -- 1000 | nA |
| Supply Current $R_L = \infty$, $T_A = 25^\circ\text{C}$ $R_L = \infty$, $V_{CC} = 30\text{V}$ | I_{CC} | -- -- | 0.4 -- | 1.0 2.5 | mA |

Dual Voltage Comparator

Notes:

1. The max. Output current may be as high as 20 mA, independent of the magnitude of V_{CC} , output short circuits to V_{CC} can cause excessive heating and eventual destruction.
2. This magnitude of input current will only occur if the input leads are driven more negative than ground or the negative supply voltage. This is due to the input PNP collector base junction becoming forward biased acting as an input clamp diode. There is also a lateral PNP parasitic transistor action on the IC chip. This phenomena can cause the output voltage of the comparators to go to the V_{CC} voltage level (or ground if overdrive is large) during the time the input is driven negative. This will not destroy the device and normal output states will recover when the inputs become -0.3 V of ground or negative supply.
3. At output switch point, $V_O = 1.4$ Vdc, $R_S = 0\Omega$ with V_{CC} from 5.0 Vdc to 30 Vdc, and over the full input common-mode
4. Due to the PNP transistor inputs, bias current will flow out of the inputs, this current is essentially constant independent of the output state, therefore, no loading changes will exist on the input lines.
5. Input common mode of either input should not be permitted to go more than 0.3 V negative of ground or minus supply. The upper limit of common mode range is $V_{CC} - 1.5$ V but either or both inputs can be taken to as high as 30 volts without damage.
6. Response time is specified with a 100 mV step and 5.0 mV of overdrive. With larger magnitudes of overdrive faster response times are obtainable.
7. The comparator will inhibit proper output state if one of the inputs become greater than V_{CC} , the other input must remain within the common mode range. The low input state must not be less than -0.3 volts of ground of minus supply.

FIGURE 1- CIRCUIT SCHEMATIC
(Diagram shown is for 1 comparator)

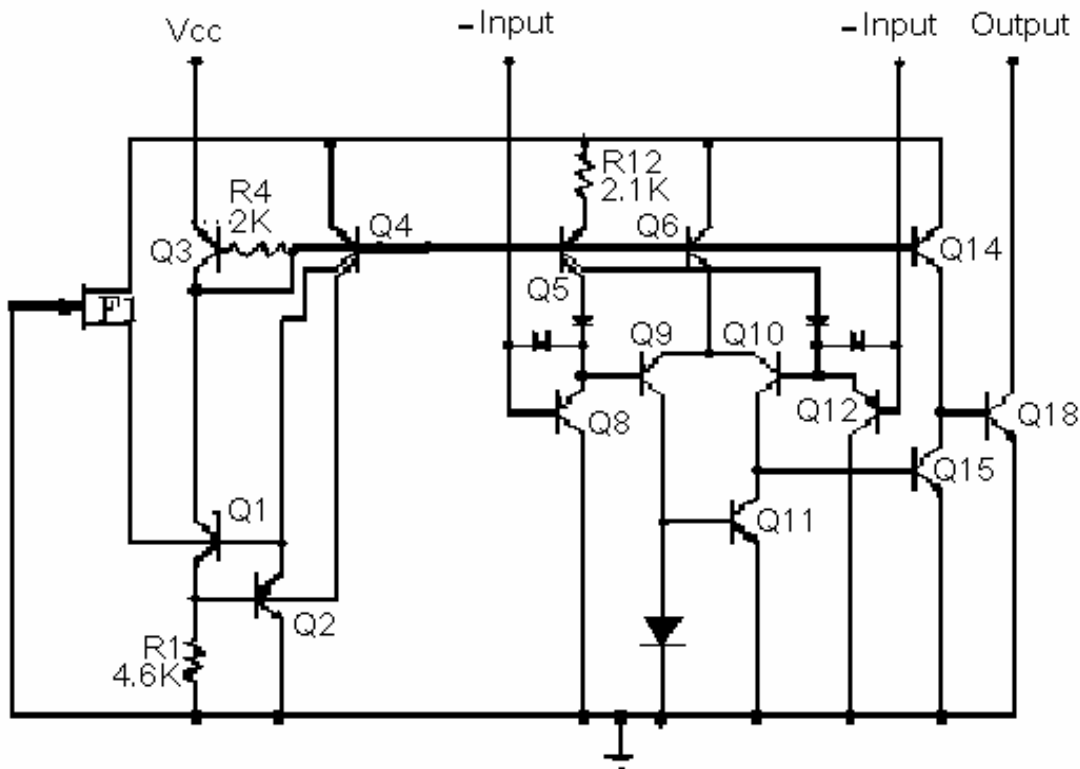

Dual Voltage Comparator

FIGURE 2 - INPUT BIAS CURRENT versus POWER SUPPLY VOLTAGE

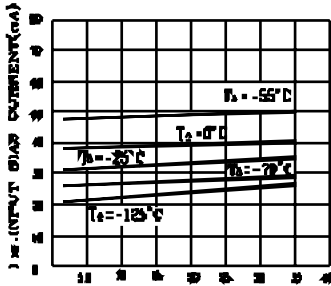

FIGURE 4 - POWER SUPPLY CURRENT versus POWER SUPPLY VOLTAGE

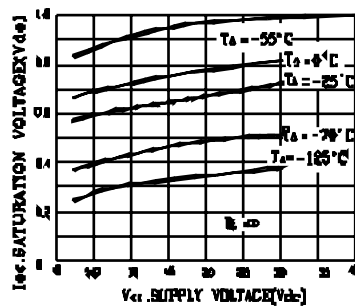
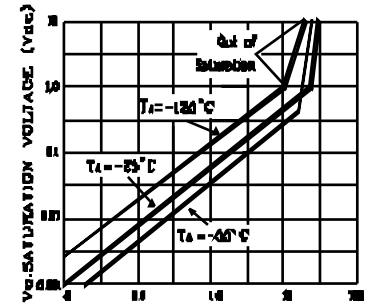

FIGURE 3 - OUTPUT SATURATION VOLTAGE versus OUTPUT SINK CURRENT



APPLICATIONS INFORMATION

This dual comparator feature high gain, wide bandwidth characteristics. This gives the device oscillation tendencies if the outputs are capacitively coupled to the inputs via stray capacitance. This oscillation manifests itself during output transitions (V_{OL} to V_{OH}). To alleviate this situation input resistors $<10K\Omega$ should be used. The addition of positive feedback (<10 mV) is also recommended.

It is good design practice to ground all unused pins.

Differential input voltages may be larger than supply voltage without damaging the comparator's inputs. Voltages more negative than -0.3 V should not be used.

FIGURE 5 - ZERO CROSSING DETECTOR (Single Supply)

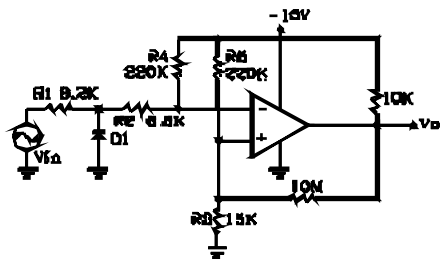
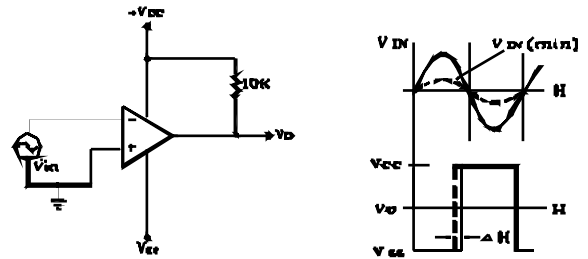

FIGURE 6 - ZERO CROSSING DETECTOR (Split Supplies)



Dual Voltage Comparator

FIGURE 7 - ZERO CROSSING DETECTOR

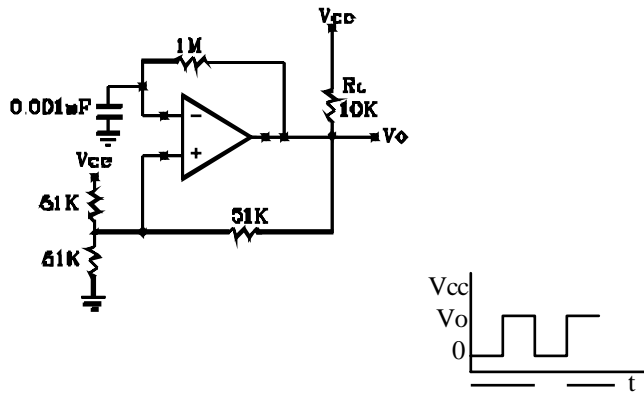

FIGURE 8 - TIME DELAY GENERATOR

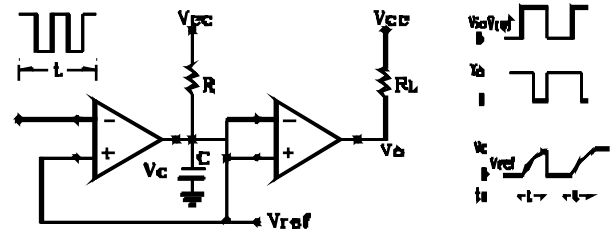
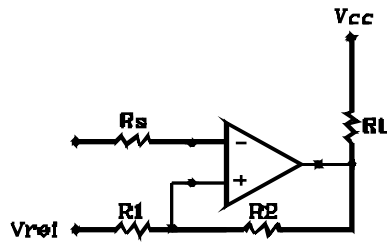

FIGURE 9 - COMPARATOR WITH HYSTERESIS

$$R_s = R_1 = R_2$$

$$V_{th1} = V_{ref} * \frac{(V_{cc} * V_{ref}) * R_1}{R_1 * R_2 * R_L}$$

$$V_{th2} = V_{ref} * \frac{(V_{ref} * V_{oLow}) * R_1}{R_1 * R_2 * R_L}$$



Dual Voltage Comparator

DIP-8

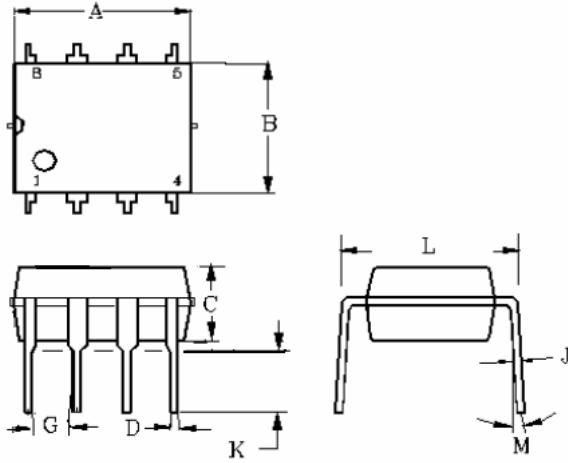

| DIM | MILLIMETERS | | INCHES | |
|-----|-------------|------|---------|-------|
| | MIN | MAX | MIN | MAX |
| A | 9.07 | 9.32 | 0.357 | 0.367 |
| B | 6.22 | 6.48 | 0.245 | 0.255 |
| C | 3.18 | 4.43 | 0.125 | 0.135 |
| D | 0.35 | 0.55 | 0.019 | 0.020 |
| G | 2.54BSC | | 0.10BSC | |
| J | 0.29 | 0.31 | 0.011 | 0.012 |
| K | 3.25 | 3.35 | 0.128 | 0.132 |
| L | 7.75 | 8.00 | 0.305 | 0.315 |
| M | - | 10° | - | 10° |

SOP-8

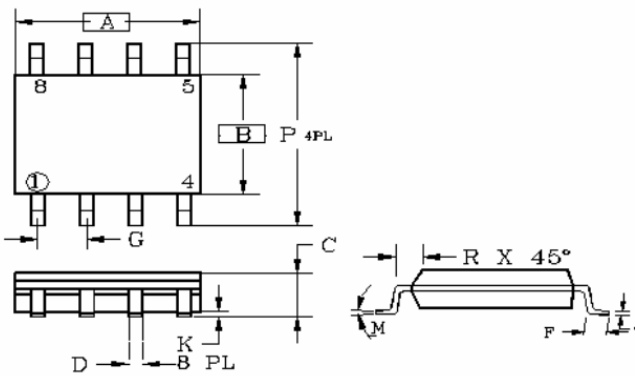

| DIM | MILLIMETERS | | INCHES | |
|-----|-------------|------|---------|-------|
| | MIN | MAX | MIN | MAX |
| A | 4.80 | 5.00 | 0.189 | 0.196 |
| B | 3.80 | 4.00 | 0.150 | 0.157 |
| C | 1.35 | 1.75 | 0.054 | 0.068 |
| D | 0.35 | 0.49 | 0.014 | 0.019 |
| F | 0.40 | 1.25 | 0.016 | 0.049 |
| G | 1.27BSC | | 0.05BSC | |
| K | 0.10 | 0.25 | 0.004 | 0.009 |
| M | 0° | 7° | 0° | 7° |
| P | 5.80 | 6.20 | 0.229 | 0.244 |
| R | 0.25 | 0.50 | 0.010 | 0.019 |