

64 Analog Input RAD Tolerant Telemetry Controller

Description

The LX7730 is a spacecraft telemetry manager IC that functions as a companion to the FPGA. The LX7730 contains a 64 universal input multiplexer that can be configured as a mix of differential or single ended sensor inputs. There is a programmable current source that can be directed to any of the 64 universal inputs. The universal inputs can be sampled with a 12 bit analog-to-digital converter at a sample rate up to 13kHz. The universal inputs can also function as variable bi-level inputs with the threshold set by an internal 8 bit digital-to-analog converter. There is an additional 10 bit digital-to-analog current DAC with complementary outputs. Finally there are 8 fixed threshold bi-level inputs.

The LX7730 is register programmable with 17 addressable eight bit registers. Two options are available for communication with the host FPGA. First there is an eight bit parallel bus with 5 address bits and a read/write bit that can communicate at a speed of up to 25MHz. The second option is a pair of 12.5Mbps SPI interfaces that can support redundant (alternating not simultaneous) communication to two different hosts.

The LX7730 offers 1 kV ESD pin protection on all CH# pins and 2kV on the other pins. The dielectric isolated process is failsafe. The LX7730 has enable registers that allow most of the device to be shut down to reduce power consumption and supports cold sparing on its signal pins.

The controller is designed for use in rugged environments. It is packaged in a 132 pin ceramic quad flat pack and operates over a -55°C to 125°C temperature range. It is radiation tolerant to 100krad TID and 50krad ELDRs as well as single event effects.

Features

- 64 channel MUX
- Break-before-make switching
- 13kSPS 12 bit ADC
- 2% Precision Adjustable Current Source
- 1% Precision 5.00V Source
- Threshold Monitoring
- 8 x Bi-level Logic
- 10 bit DAC
- Parallel or Dual SPI Interface
- Radiation Tolerant: 100krad TID, 50kad ELDRS

Applications

- Spacecraft Health Monitoring
- Attitude Control
- Payload Equipment

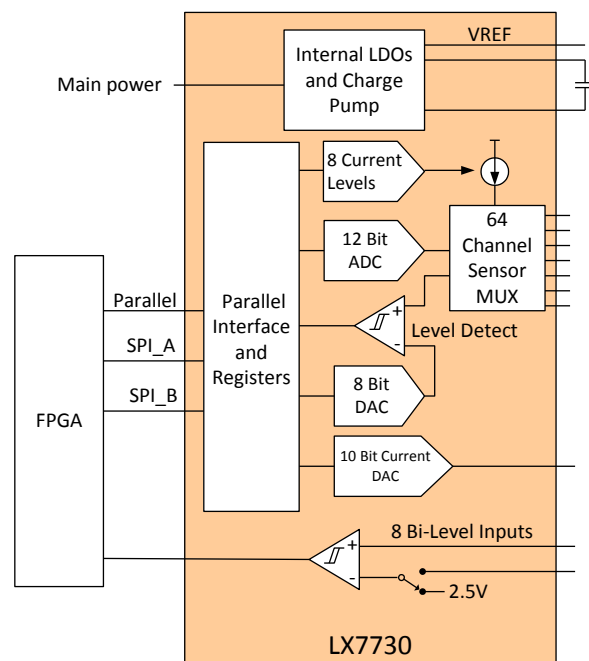

Figure 1 · Product Highlight

Pin Configuration and Pinout

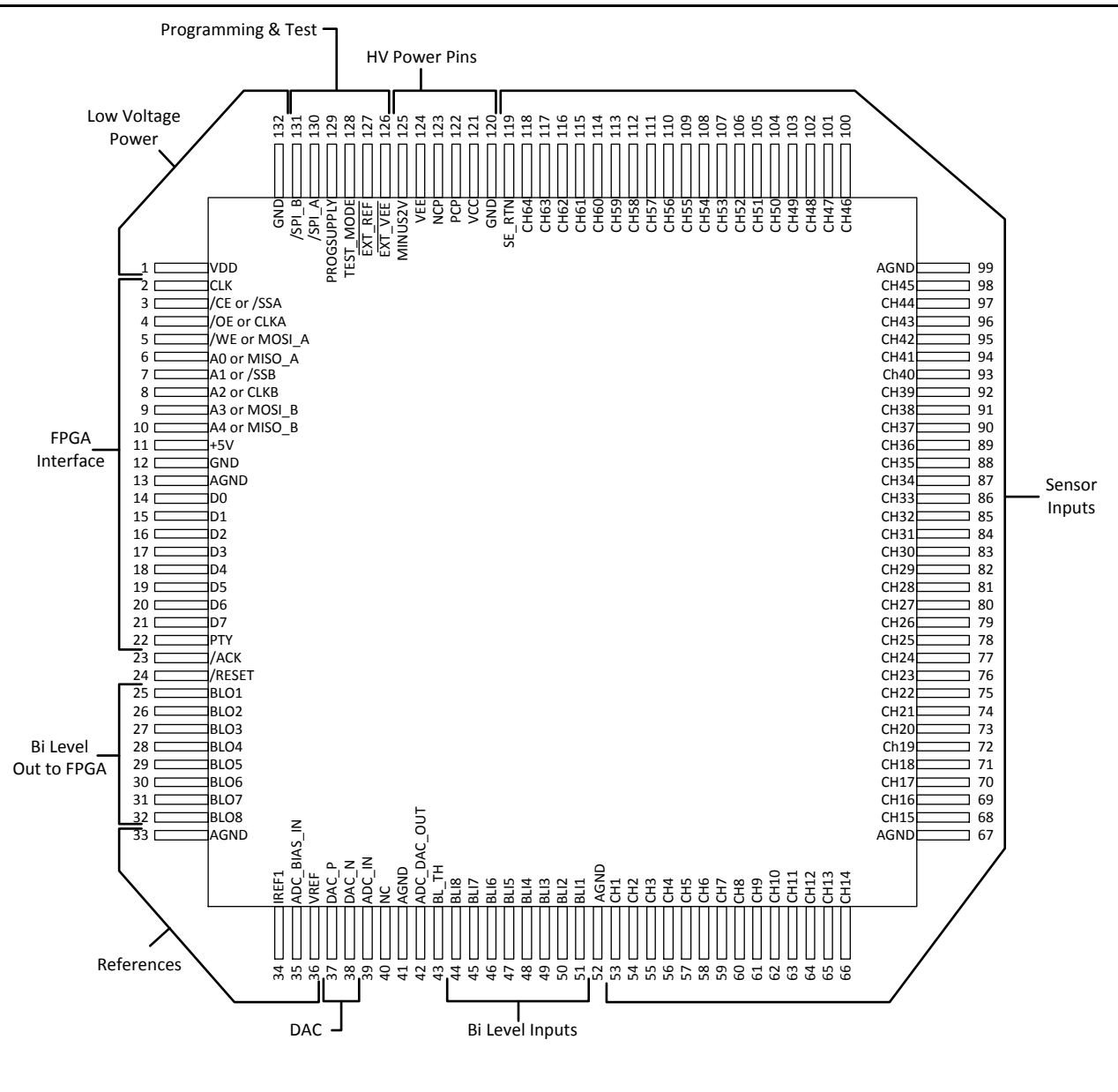

Figure 2 · Pinout

Ordering Information

Operating Temperature	Type	Package	Part Number	Packaging Type
-55°C to 125°C	MIL-PRF-38535 Class V	CQFP 132L	LX7730MFQ-EV	Bulk / Tray
-55°C to 125°C	MIL-PRF-38535 Class Q	CQFP 132L	LX7730MFQ-EQ	Bulk / Tray
Commercial	Engineering Samples	CQFP 132L	LX7730-ES	Bulk

Pin Description

Pin Number	Pin Designator	Description
1	VDD	VDD - Power reference pin – This pin is used to reference the output logic level to the FPGA. It connects to the FPGA I/O power supply.
2	CLK	System Clock – Logic Input – This clock input is used to time synchronous logic needed to perform the ADC conversions. There is a weak pull-down on this pin.
3	/CE or /SSA	Chip enable or Slave Select channel A – Logic Input – Provides chip enable for the parallel interface when /SPI_A and /SPI_B are high. Provides slave select for the SPI channel A interface when the /SPI_A pin is pulled low. In both cases the logic is active low. There is a weak pull-up on this pin.
4	/OE or CLKA	Output enable or SPI Clock channel A – Logic Input – Provides output enable (read enable) for the parallel interface when /SPI_A and /SPI_B are high. Provides the clock for the SPI channel A interface when the /SPI_A pin is pulled low. There is a weak pull-up on this pin.
5	/WE or MOSI_A	Write enable or SPI MOSI channel A – Logic Input – Provides active low write enable for the parallel interface when /SPI_A and /SPI_B are high. Provides data input for the SPI channel A interface when the /SPI_A pin is pulled low. There is a weak pull-up on this pin.
6	A0 or MISO_A	Address bit 0 or SPI MISO channel A – Logic I/O – Provides the address bit 0 (LSB) for the parallel interface when /SPI_A and /SPI_B are high. Provides data output for the SPI channel A interface when the /SPI_A pin is pulled low. There is a weak pull-down on this pin.
7	A1 or/SSB	Address bit 1 or Slave Select channel B – Logic Input – Provides the address bit 1 for the parallel interface when /SPI_A and /SPI_B are high. Provides slave select for the SPI channel B interface when the /SPI_B pin is pulled low. There is a weak pull-up on this pin.
8	A2 or CLKB	Address bit 2 or SPI Clock channel B – Logic Input – Provides the address bit 2 for the parallel interface when /SPI_A and /SPI_B are high. Provides the clock for the SPI channel B interface when the /SPI_B pin is pulled low. There is a weak pull-down on this pin.
9	A3 or MOSI_B	Address bit 3 or SPI MOSI channel B – Logic I/O – Provides the address bit 3 for the parallel interface when /SPI_A and /SPI_B are high. Provides data input for the SPI channel B interface when the /SPI_B pin is pulled low. There is a weak pull-down on this pin.
10	A4 or MISO_B	Address bit 4 or SPI MISO channel B – Logic I/O – Provides the address bit 4 (MSB) for the parallel interface when /SPI_A and /SPI_B are high. Provides data output for the SPI channel B interface when the /SPI_B pin is pulled low. There is a weak pull-down on this pin.
11	+5V	+5V power rail – Power Pin – This pin is the low voltage power rail. It is generated internally using a linear regulator connected to the VCC rail. A bypass capacitor to GND is required.
12, 120, 132	GND	Ground – Power and Signal pin – These pins provide a return path for power supplies and a reference point for signals.
13, 33, 41, 52, 67, 99	AGND	Analog Ground –Signal pin – These pin provides a reference point for signals.

Pin Number	Pin Designator	Description
14-21	D#	Data I/O for the parallel interface – Logic I/O - Provides the data bits, D0 (LSB) (pin 14) through D7 (pin 21) for the parallel interface. There is a weak pull-down on these pins.
22	PTY	Parity I/O Bit – Logic I/O – Provides the parity bit for the parallel data communication. Even parity is used for the combination of address and data bits and is used in both directions. There is a weak pull-down on this pin.
23	/ACK	Acknowledge Bit – Logic Output – In the event of a parity error encountered in a serial or parallel data transfer, the /ACK pin is de-asserted (pulled high). see “FPGA Interface” for conditions.
24	/RESET	System Reset – Logic Input– This pin provides a forced reset to the default state of all registers and flip-flops within the LX7730. The logic is active low which requires the pin to be pulled low to assert a reset.
25-32	BLO#	Fixed Threshold Bi Level detector output to FPGA – Logic Output– Provides the state of the Fixed Level Bi Level Input of the same # directly to the FPGA.
34	IREF1	Reference current programming pin –Signal Input – This pin is used to create a precision reference current for the IC. A 20kΩ resistor should be attached from this pin to AGND. IREF2 is an internal redundant resistor and can be selected should IREF1 fail.
35	ADC_BIAS_IN	ADC Reference current programming pin –Signal Input – This pin is used to create a precision reference current for the ADC. A 7.87kΩ resistor should be attached from this pin to AGND.
36	VREF	+5V reference – Signal Output – This pin is a precision reference voltage that can be used to provide a voltage reference to sensors for precision measurements. A bypass capacitor to AGND is required. The internal reference can be disabled and an external reference connected to this pin; the internal voltage reference must be disabled in this case using the /EXT_REF programming pin.
37,38	DAC_#	10 Bit Current DAC output – Signal Pin – This pin provides the output for the 10 bit current DAC; it should be terminated in a resistor of 1.5kΩ or less to AGND. The DAC_P output increases with the LSB level and the DAC_N output decrease with the LSB level. DAC_P maximum occurs at full scale setting and DAC_N output maximum occurs at zero setting. If the “Use DAC” bit is asserted; this implies the DAC is used to control the current setting of the Current De-Mux. In this case the DAC_P should be left open circuited and the DAC_N terminated to GND.
39	ADC_IN	Analog to Digital Converter Input – Signal Pin – This pin is used to monitor the output of the anti-aliasing filters or to provide an input signal directly into the ADC from an external source. When used as an input, the anti-aliasing filter can be put in a Hi-Z output state.
40	NC	No Connect – Test Pin – This pin is used for testing and should be left floating in the application.
42	ADC_DAC_OUT	ADC gain scale current programming pin –Signal Input – This pin is used to create a precision load for the current DAC portion of the SAR ADC. A 158Ω resistor should be attached from this pin to AGND.
43	BL_TH	External Bi-Level Threshold Setting – Signal Pin – This pin is used to

Pin Number	Pin Designator	Description
		override the internal 2.5V bi-Level threshold setting and change it to the voltage applied to this pin. An addressable register bit is used to select either the internal or external bi-level threshold.
44-51	BLI#	Fixed threshold Bi Level Signal Input – Signal Input Pin – This pin is fixed threshold bi-level input: channel 8 (pin 44) decreasing to channel 1 (pin 51).
53-118	CH#	General purpose sensor interface – Signal I/O - This pin provides input for the sensor interface or output for the adjustable current source. Channel 1 (pin 53) to channel 64 (pin 118). A few AGND pins are interspersed.
119	SE_RTN	Single Ended Sensor Return – Signal Pin – This pin is used as a common return for single ended sensor inputs.
121	VCC	Main power supply – Power Input – This pin is the main power supply. The internal (VEE and +5V) voltage regulators are powered from this rail.
122	PCP	Charge Pump Transfer Capacitor Positive Terminal – Power Pin – This pin is used for the charge pump used to generate VEE; it swings between GND and VCC. Connect a 0.47 μ F capacitor between this pin and the NCP pin.
123	NCP	Charge Pump Transfer Capacitor Negative Terminal – Power Pin – This pin is used for the charge pump used to generate VEE; it swings between GND and VEE. Connect a 0.47 μ F capacitor between this pin and the PCP pin.
124	VEE	Negative power rail – Power I/O – This pin is the negative voltage power rail. It can be generated internally (using the charge pump) or supplied from an external source connected to this pin. Use a bypass capacitor to GND. The charge pump can be disabled by shorting the /EXT_VEE pin to GND.
125	MINUS2V	-2V Intermediate power rail – Power Pin – This pin is the low negative voltage power rail. It is generated internally using a linear regulator connected to the VEE rail. A bypass capacitor to GND is required.
126	/EXT_VEE	Enable external VEE – Programming pin – This pin disables the VEE charge pump if it is shorted to ground. If high, the VEE charge pump is enabled. There is a weak pull-up on this pin.
127	/EXT_REF	Enable External Reference – Programming pin – This pin disables the internal voltage reference when it is shorted to ground. If high, the internally generated voltage reference is used. There is a weak pull-up on this pin.
128	TEST_MODE	Test and Trim Pins – Programming Pins - This pin is used for in package trim and testing of the device. In normal use it should be connected to GND.
129	PROGSUPPLY	Trim Power Supply – Power Pin – This pin is used to blow fusible links when trimming the part in package at the factory. In normal application this pin should be shorted to +5V.
130	/SPI_A	Enable SPI Interface A – Logic Input – This pin is active low. Asserting this pin enables the SPI channel A interface and deactivates the parallel interface and SPI channel B. If both /SPI_A and /SPI_B pins are low, the first asserted pin dominates. There is a weak pull-up on this pin.
131	/SPI_B	Enable SPI Interface B – Logic Input – This pin is active low. Asserting this pin enables the SPI channel B interface and deactivates the parallel interface and SPI channel A. If both /SPI_A and /SPI_B pins are low, the first asserted pin dominates. There is a weak pull-up on this pin.

Functional Block Diagram

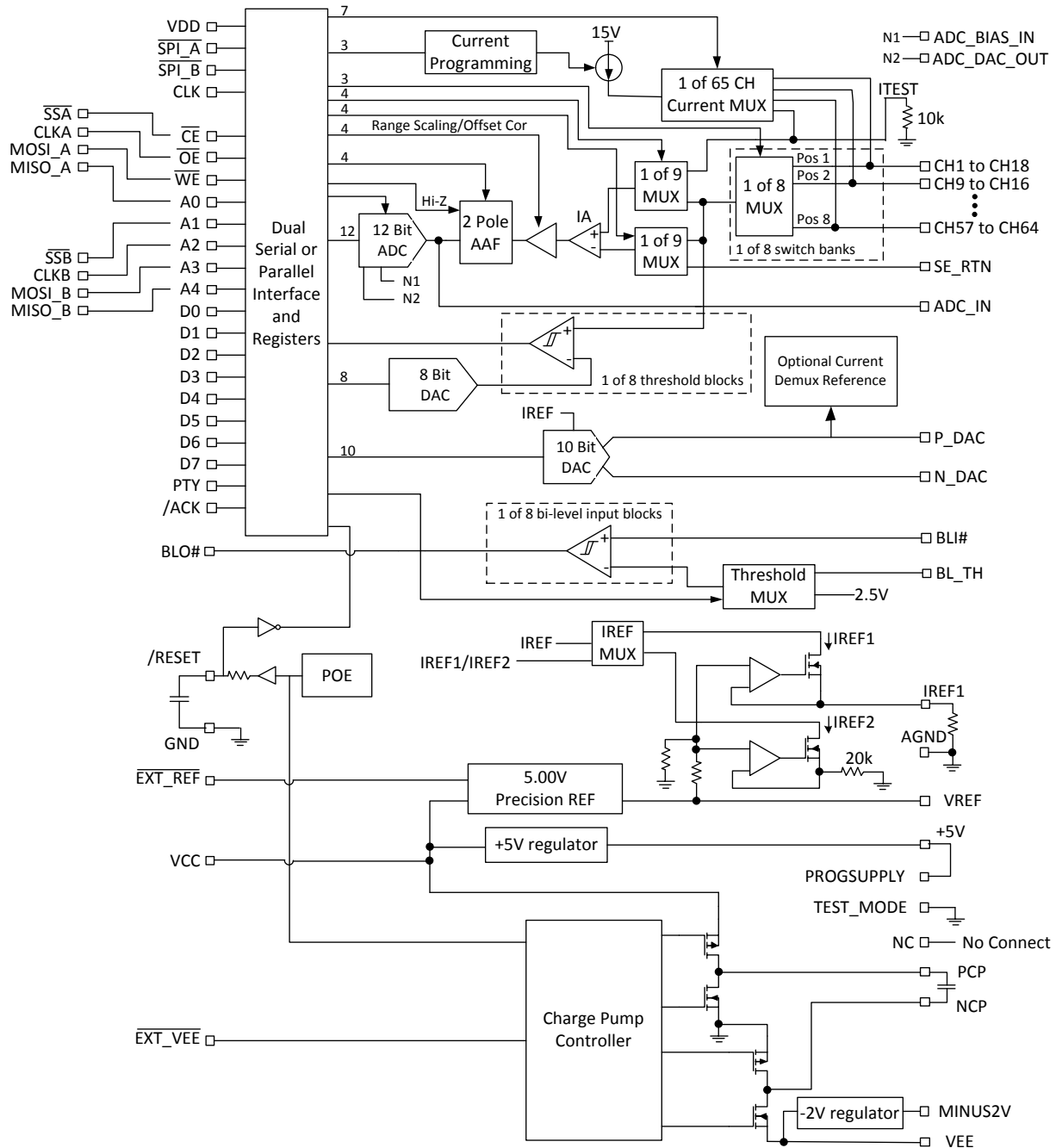

Figure 3 · LX7730 Top Level Block Diagram

Functional Block Diagram

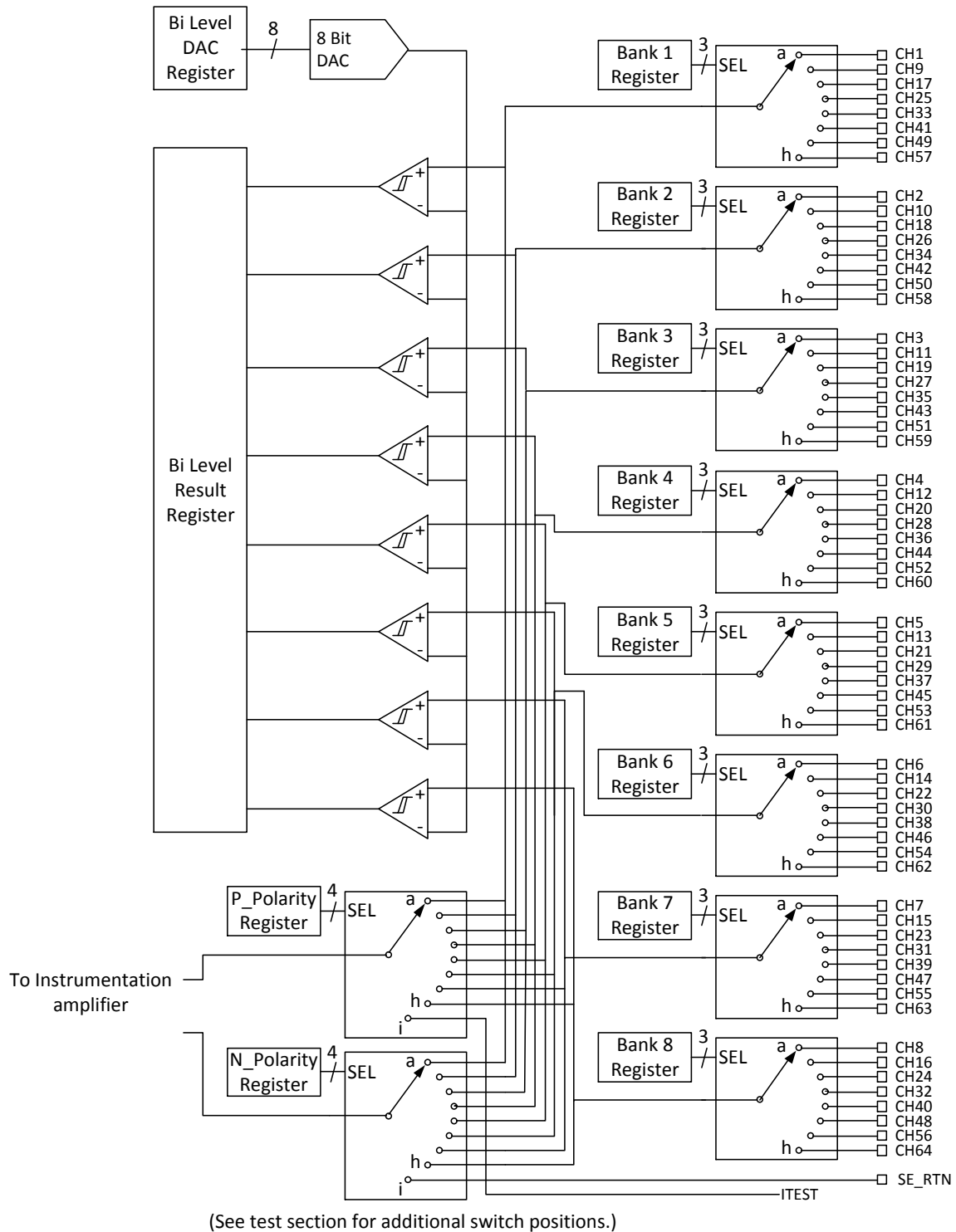

Figure 4 · LX7730 Sensor Multiplexer Expanded View Block Diagram

Absolute Maximum Ratings

Note: Stresses above those listed in “ABSOLUTE MAXIMUM RATINGS”, may cause permanent damage to the device. This is a stress only rating and operation of the device at these or any other conditions above those indicated in the operational sections of this specification is not implied.

Parameter	Min	Max	Units
Main Power (VCC) to GND	-0.5	20	V
Logic Supply Voltage (VDD) to GND	-0.5	7	V
+5V (current internally limited)	-0.5	7	V
VEE (current internally limited)	-20	+0.5	V
FPGA interface (Pins 2 thru 32) to GND	-0.5	7	V
Sensor Inputs (CH1 - CH64, SE_RTN) to GND	-15	15	V
Bi-Level Inputs (BLI1 to 8) to GND	-10	10	V
Input clamp currents		3	mA
ADC_IN, AI_OUT, DAC_N/P, RESET, VREF, BL_TH, IREF# to GND	-0.5	7	V
Operating Junction Temperature	-55	150	°C
Storage Junction Temperature	-65	160	°C
ESD Susceptibility (HBM, ML_STD883, Method 3015.7) Except as noted: TBD		2	kV
Peak Lead Solder Temperature (10 seconds)		260 (+0, -5)	°C

Operating Ratings

Note: Performance is generally guaranteed over this range as further detailed below under Electrical Characteristics.

Parameter	Min	Max	Units
VCC	11.4	16	V
VDD	2.25	5.5	V
VEE (when externally applied)	-16	-10	V
+5V (current internally limited)	4.5	5.5	V
FPGA Interface (Pins 2 thru 32) to GND		5.5	V
Sensor Inputs (CH1 - CH64, SE_RTN) to GND		10	V
Bi-Level Inputs (BLI1 to 8) to GND		8	V
Input Clamp Currents		Fault condition ≤ 3	mA
ADC_IN, AI_OUT, DAC_N/P, RESET, VREF, BL_TH, IREF# to GND		5.5	V
Current from Reference Voltage (VREF pin)	0	10	mA

Thermal Properties

Thermal Resistance	Typ	Units
θ_{JC}	2	°C/W

Note: The θ_{JA} numbers assume no forced airflow. Junction Temperature is calculated using $T_J = T_A + (PD \times \theta_{JA})$. In particular, θ_{JA} is a function of the PCB construction. The stated number above is for a four-layer board in accordance with JESD-51 (JEDEC).

Electrical Characteristics

The following specifications apply over the operating ambient temperature of $-55^{\circ}\text{C} \leq T_A \leq 125^{\circ}\text{C}$ except where otherwise noted with the following test conditions: $V_{CC} = 15\text{V}$, $V_{DD} = 3.3\text{V}$; $R_{IREF} = 20\text{k}\Omega$; $R_{ADC_BIAS_IN} = 7.87\text{k}\Omega$; $R_{ADC_DAC_OUT} = 158\Omega$; / EXT_VEE open, /EXT_REF open. CH1 and CH2 selected and CH2 grounded. CLK = 500kHz. Reg 7 = 001010xx. Typical parameter refers to $T_J = 25^{\circ}\text{C}$. Positive currents flow into the pin.

Symbol	Parameters	Test Conditions/Comments	Min	Typ	Max	Units
Operating Current						
I_{VCC}	VCC Normal Current		55	70	85	mA
I_{VCC}	VCC Standby Current	Chip Enable Register de-asserted	2.0	4.0	7.0	mA
I_{VEE}	VEE Current	Using external VEE source. Positive current out of pin.	-3.5	-4.7	-6.0	mA
Under Voltage Detection						
V_{VCC}	VCC UVLO	Voltage rising; 200mV Hysteresis	9.5	10	10.5	V
V_{VEE}	VEE UVLO	Voltage falling; 200mV Hysteresis	-8.2	-8.0	-7.8	V
V_{+5V}	+5V UVLO	Voltage rising; 200mV Hysteresis	3.9	4.15	4.4	V
Internally Regulated Voltages and Currents						
V_{VEE}	VEE voltage	$V_{CC} - V_{VEE} $	2.0	2.6	2.9	V
V_{+5V_NOM}	+5V voltage		4.8	5.00	5.20	V
V_{REF_NOM}	VREF voltage		4.95	5.00	5.05	V
V_{IREF}	IREF pin voltage	$R_{IREF} = 20\text{k}\Omega$	1.568	1.600	1.632	V
Analog MUX						
$V_{CH\#}$	Differential Range	CH# to CH# or CH# to SE_RTN	0		5	V
$V_{CH1} \& V_{CH2}$	Common Mode Range	With $V_{CH1} - V_{CH2} = 5\text{V}$	-5		5	V
$V_{CH\#}$	Voltage Clamp (power applied)	Clamp Current = 1mA (into pin) ⁽¹⁾	15	16	17	V
		Clamp Current = 1mA (out of pin)	-23	-20	-17	
$V_{CH\#}$	Voltage Clamp ($V_{CC}=V_{EE}=0$)	Clamp Current = 1mA (into pin)	17	20	23	V
		Clamp Current = 1mA (out of pin)	-23	-20	-17	
All to V_{CH1}	Ch – Ch Isolation	CH1 and SE_RTN selected; CH2 to CH64 each with series 2k Ω to a 10kHz common source, CH1 with 2k Ω to GND. SE_RTN to GND.		60		dB
V_{ADC_IN}	Settling Time	Including dead time			10	μs
$I_{CH\#}$	Bias Current	$V_{CH1} = -5\text{V}$ to 5V	-200	0	200	nA
$I_{CH\#}$	Leakage Current	$V_{CH1} = -5\text{V}$ to 5V; IC powered off	-200	0	200	nA
I_{SE_RTN}	Bias Current	$V_{SE_RTN} = -5\text{V}$ to 5V	-200	0	200	nA

Symbol	Parameters	Test Conditions/Comments	Min	Typ	Max	Units
I _{SE_RTN}	Leakage Current	V _{SE_RTN} = -5V to 5V; IC powered off	-200	0	200	nA
Programmable Current Source						
I _{CH#}	Full scale current	Use_DAC off; Doub_Wt off	1880	1940	2000	μA
I _{CH#}	Integral nonlinearity	Use_DAC off; Doub_Wt off	-7.5	0	7.5	
I _{CH#}	Differential nonlinearity	Use_DAC off; Doub_Wt off	-7.5	0	7.5	
I _{CH#}	Full scale current	Use_DAC off; Doub_Wt on	3710	3830	3950	
I _{CH#}	Integral nonlinearity	Use_DAC off; Doub_Wt on	-15	0	15	
I _{CH#}	Differential nonlinearity	Use_DAC off; Doub_Wt on	-15	0	15	
I _{CH#}	At DAC = code 31	Use_DAC asserted	290	300	310	
I _{CH#}	Integral nonlinearity	Use_DAC asserted; straight line from 0 to code 31.	-2	0	2	
I _{CH#}	Differential nonlinearity	Use_DAC asserted; first 31 codes.	-2	0	2	
I _{CH#}	Settling Time	To within 5% tolerance			10	μs
Instrumentation Amplifier with gain control (measured at ADC_IN)						
V _{ADC_IN}	Offset Voltage = (Vo1/M) - Vi1	Gain = 0.4; Referenced to Input -55°C , 25°C	-2	13	25	mV
		Gain = 0.4; Referenced to Input 125°C	-2	13	30	
		Gain = 2.0; Referenced to Input -55°C , 25°C	-3	0	3	
		Gain = 2.0; Referenced to Input 125°C	-3	0	4	
		Gain = 10; Referenced to Input -55°C , 25°C	-3	0	3	
		Gain = 10; Referenced to Input 125°C	-3	0	3	
AV _{AMP}	Gain = (Vo2 - Vo1)/(Vi2 - Vi1)	Gain = 0.4	0.398	0.400	0.402	Vout/Vin
		Gain = 2.0	1.992	1.998	2.004	
		Gain = 10	9.965	9.995	10.025	
V _{ADC_IN}	Output Step Rise Time Reg 7 =001010xx 10% to 90%; Vo =2Vpp	Gain = 0.4	120	210	333	us
		Gain = 2.0	31	52	87	
		Gain = 10	31	52	87	
V _{ADC_IN}	Pole frequency	Set Reg 7 for 400Hz	360	600	1000	Hz
V _{ADC_IN}	Pole frequency	Set Reg 7 for 2kHz	1.4	2.8	3.8	kHz
V _{ADC_IN}	Pole frequency	Set for 10kHz	8.8	13.5	18.2	kHz
Analog-to-Digital Converter (input at ADC_IN)						
V _{ADC_IN}	Linear Range	Input applied to ADC_IN	0		2.0	V
V _{ADC_IN}	Full scale error	Best fit curve applied to full range	-2.5	0	2.5	%
V _{ADC_IN}	Offset Error		-10	0	10	mV
V _{ADC_IN}	Integral nonlinearity	-55°C , 25°C	-6	0	6	LSB
		125°C	-7	0	7	
V _{ADC_IN}	Differential nonlinearity		-1	0	3	

Symbol	Parameters	Test Conditions/Comments	Min	Typ	Max	Units
I _{ADC_IN}	Leakage current	Internal amplifier in Hi-Z state; ADC not converting	-0.2	0	0.2	μA
t _{CONV}	Conversion Time	Cycles of CLK pin		13		clocks
t _{ACQU}	Acquisition Time			25		
t _{SAMP}	Sample Period			38		
Adjustable threshold Bi-Level MUX and DAC						
V _{CH#}	Threshold DAC Max Output	Using code value of 255/255	4.95	5.00	5.05	V
V _{CH#}	Threshold DAC LSB Weight			19.5		mV
V _{CH#}	DAC Integral Linearity	Using codes 20 to 240, best fit straight line	-1		1	LSB
V _{CH#}	Offset error		-10		10	mV
V _{CH#}	DAC Differential Linearity		-0.75		0.75	LSB
V _{CH#}	Hysteresis	Rising threshold = DAC output; falling threshold has hysteresis	75	112	150	mV
10 Bit Current DAC						
I _{DAC_P}	Full scale		-2.06	-2.00	-1.94	mA
I _{DAC_N}	Full scale			0		mA
I _{DAC_P,N}	LSB Weight			-1.953		μA
I _{DAC_P,N}	Integral Nonlinearity		-5	0	5	LSB
I _{DAC_P,N}	Differential Nonlinearity		-0.5	0	0.5	LSB
V _{DAC_P,N}	Compliance Range		0		3	V
I _{DAC_P,N}	Settling			0.2	1	μs
Fixed Threshold Bi-Level Inputs						
V _{BLI#}	Threshold (Rising Voltage)	Internal reference	2.45	2.50	2.55	V
		With external 2.50V reference	2.45	2.50	2.55	
V _{BLI#}	Hysteresis	Only falling threshold has hysteresis; Rising is dead on	60	120	180	mV
V _{BLI#}	Voltage Clamp (power applied)	Clamp Current = 1mA (into pin)	15	20	23	V
		Clamp Current = 1mA (out of pin)	-23	-20	-15	
V _{BLI#}	Voltage Clamp (power removed)	Clamp Current = 1mA (into pin)	15	20	23	V
		Clamp Current = 1mA (out of pin)	-23	-20	-15	
I _{BLI#}	Bias Current	V _{BLI1} = 0V to 5V	-0.2	0	1.5	μA
I _{BLI#}	Leakage Current	V _{BLI1} = 0V to 5V; IC powered off	-0.2	0	1.5	μA
t _{BLI#}	Propagation Delay	High to low transition	0.3	0.8	1.3	μs
		Low to high transition	0.8	2.1	3.4	
V _{BL_TH}	Ext Threshold Pin Range		0.1		4.9	V
I _{BL_TH}	Threshold Pin Leakage	V _{BL_TH} = 0V to 5V	-0.2	0	2.0	μA

Logic Levels for FPGA Interface I/Os						
V _{LOG_IN}	Input Logic Threshold	Threshold Voltage	35	50	65	%VDD
V _{EXT_VEE} , V _{EXT_VREF}	Program pins	Threshold Voltage	2.0	2.5	3.0	V
V _{LOG_OUT}	Logic Output Levels	High Logic Level (100μA source)	VDD-0.3		VDD	V
		Low Logic Level (100μA sink)	0		0.3	
I _{LOG_IN}	Input currents	/SPI_A, /SPI_B: VLOG_IN = 3.3V	-2	0	2	μA
		/SPI_A, /SPI_B: VLOG_IN = 0V	-10	-4	-1.5	
		Pins 2,6,8-10,14-21, 22: I/O as input VLOG_IN = 3.3V	1.5	4	10	
		Pins 2,6,8-10,14-21, 22: I/O as input VLOG_IN = 0V	-2	0	2	
		Pins 3-5,7: I/O as input VLOG_IN = 3.3V	-2	0	2	
		Pins 3-5,7: I/O as input VLOG_IN = 0V	-10	-4	-1.5	
		/EXT_VREF or /EXT_VEE = 5V	-2	0	2	
		/EXT_VREF or /EXT_VEE = 0V	-12	-6	-1.5	
		/RESET with power on enabled: VLOG_IN = 3.3V	-1.5	4	10	
		/RESET with power on enabled: VLOG_IN = 0V	-150	-66	-33	

(1) Voltage Clamp (power applied) 1mA into pin will clamp to the VCC supply

Register Map

Note: Each register has an address which is selectable using the address bits. All registers can be read by asserting the OE line. All registers can be written to (with the exception of the ADC High and Low Bytes) by asserting the WE line.

Addr	Type	Name	Bit 7	Bit 6	Bit 5	Bit 4	Bit 3	Bit 2	Bit 1	Bit 0	
0	W	Master reset	0	1	1	0	1	0	1	0	
1	R/W	Function enable	Chip Enable	Sensor MUX	Current Source Disable	Bi-Lvl Comp	Analog Amp	10 Bit DAC	Fixed Bi-Lvl	12 bit ADC	
2	R/W	Power status	Use IREF2	Mon VCC	Mon VEE	Mon +5V	Mon VREF	VCC UVLO	VEE UVLO	+5V UVLO	
3	R/W	Non-Inv MUX Channel	Not Used			Non-inverting Input MUX Channel Selection					
4	R/W	Inverting MUX Channel	-	Use SE_RTN	Inverting Input MUX Channel Selection (Overridden if SE_RTN bit set)						
5	R/W	Current MUX Level	Use DAC	Not Used			Double Weight	Current Setting (1 to 8)			
6	R/W	Current MUX Channel	Not Used			Current Channel Selection (1 to 64)					
7	R/W	Signal Conditioning Amp	-	AAF Off	2 nd Pole Freq.		1st Pole Freq.		Gain Setting		
8	R/W	ADC Control	Auto Sample Rate			Auto Conv	Data Ready	Busy	Start Conv	ADC_IN = HiZ	
9	RO	ADC Upper Byte	Upper Byte for the 12 bit ADC								
10	RO	ADC Lower Bits	Not Used				Lower Bits for the 12 bit ADC				
11	R/W	BL Theshold DAC	Threshold DAC setting								
12	R/W	Bi-Level Bank Switch Position	Use BL_TH	Not Used			EN BL Sw Pos	1 of 8 switch positions			
13	RO	Bi-Level Status	Comp 7	Comp 6	Comp 5	Comp 4	Comp 3	Comp 2	Comp 1	Comp 0	
14	R/W	DAC Upper Byte	Upper byte for 10 bit DAC output								
15	R/W	DAC Lower Bits	Not Used						Lower bits		
16	R/W	Calibration	IA Short	Not Used		Cont Check	NP TEST	Not Used	I GND	-	
17	R/W	OTP	Not Used						OTP_out_select	OTP_in_select	

There are 32 addressable registers. Some will be reserved for self-test. For details about each register see Theory of Operation Section below.

Trimming / Test Register

Addr	Bit 7	Bit 6	Bit 5	Bit 4	Bit 3	Bit 2	Bit 1	Bit 0
18	cmux 2	cmux 1	cmux 0	vref 4	vref 3	vref 2	vref 1	vref 0
19	vbgtc 3	vbgtc 2	vbgtc 1	vbgtc 0	offs 3	offs 2	offs 1	offs 0
20	vbg 4	vbg 3	vbg 2	vbg 1	vbg 0	vtoi 4	vtoi 3	vtoi 2
21	vtoi 1	vtoi 0	osc 3	osc 2	osc 1	osc 0	ADCvtoi 4	ADCvtoi 3
22	ADCvtoi 2	ADCvtoi 1	ADCvtoi 0					
23	lo_dis							

Trimming

One time trimming circuits will set the default for all trimming bits. Using the OTP_in_select bit the defaults can be read by the SPI or parallel bus. Writing to the trimming registers along with the OTP_out_select bit allows the defaults to be modified; when OTP_out_select is de-asserted, the trim values revert back to the default state.

Name	Bits	Description
cmux	3	Adjust 10bit I DAC reference
vref	5	Vref adjust
vbgtc	4	Bandgap temperature coefficient adjust
offs	4	Instrumentation amplifier offset adjust
vbg	5	Bandgap value adjust
vtoi	5	Programmable current source adjust (global vtoi adjust, trimmed first)
osc	4	Charge pump clock adjust
ADCvtoi	5	ADC current reference adjust
lo_dis	1	Disables the output of all i/o pins for the input threshold test

Typical Application

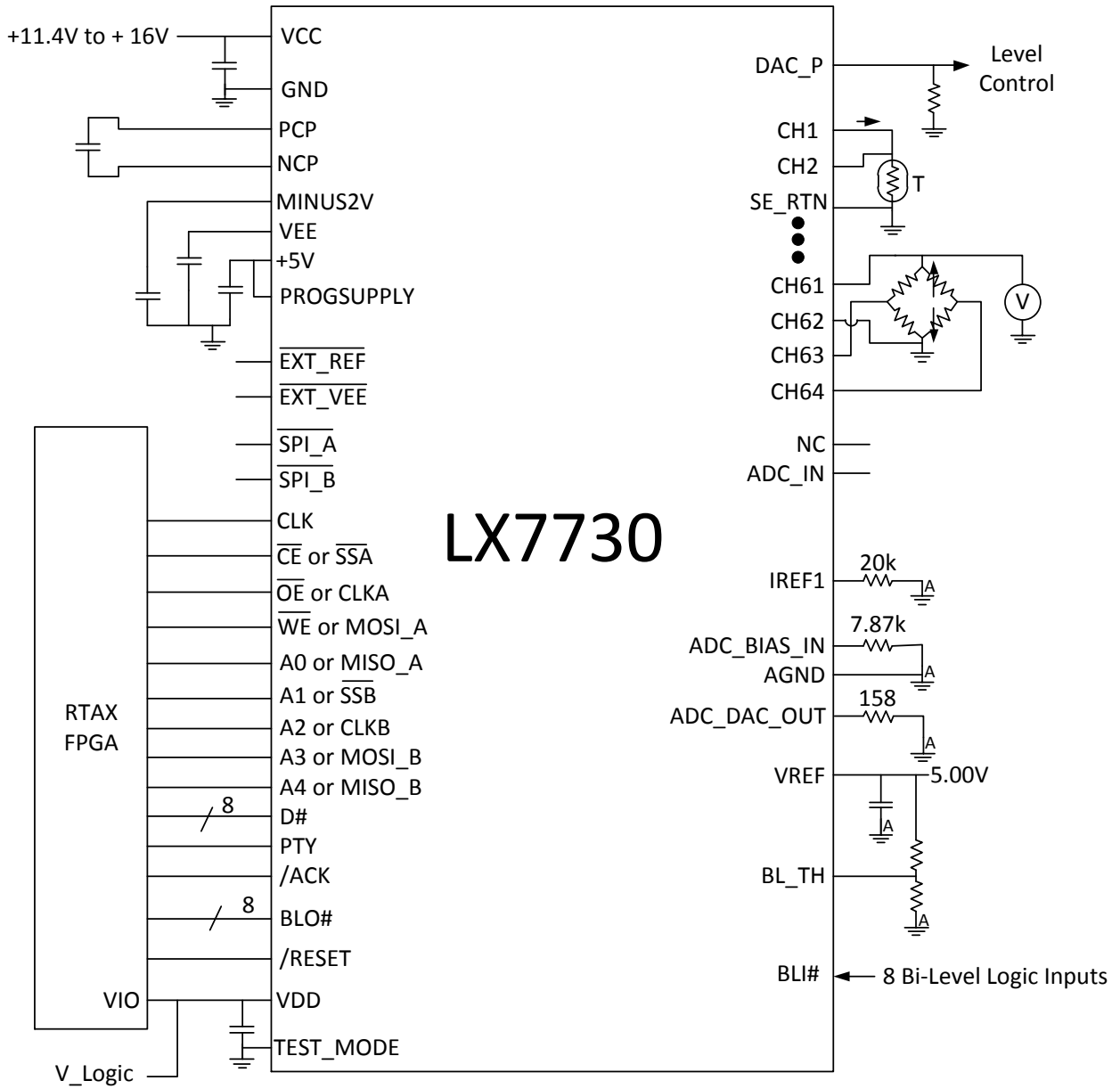

Figure 5 · Typical Application

Theory of Operation

Analog Multiplexer

The analog multiplexer (AMUX) consists of 64 inputs. There are two outputs which are the non-inverting and inverting inputs of the following instrumentation amplifier stage. Since the ADC processes only positive voltages, the input voltage at the non-inverting channel is expected to be greater than or equal to the inverting channel. The AMUX is physically divided into eight banks of eight inputs. Only one CH#, from one input bank can be selected at a time which means that differential measurements must consist of two CH#s from two different input banks. For a single ended input measurement the common SE_RTN reference pin can be selected by asserting the appropriate bit in the inverting terminal AMUX register. The EN_BL SW POS bit of register 12 must be de-asserted to use the analog multiplexing registers (3 and 4). The address bits for the Analog MUX (registers 3 and 4) are shown in the table below.

		Pos 0	Pos 1	Pos 2	Pos 3	Pos 4	Pos 5	Pos 6	Pos 7
	Bits [2:0]	000	001	010	011	100	101	110	111
	Bits [5:3]								
Bank 0	000	CH1	CH9	CH17	CH25	CH33	CH41	CH49	CH57
Bank 1	001	CH2	CH10	CH18	CH26	CH34	CH42	CH50	CH58
Bank 2	010	CH3	CH11	CH19	CH27	CH35	CH43	CH51	CH59
Bank 3	011	CH4	CH12	CH20	CH28	CH36	CH44	CH52	CH60
Bank 4	100	CH5	CH13	CH21	CH29	CH37	CH45	CH53	CH61
Bank 5	101	CH6	CH14	CH22	CH30	CH38	CH46	CH54	CH62
Bank 6	110	CH7	CH15	CH23	CH31	CH39	CH47	CH55	CH63
Bank 7	111	CH8	CH16	CH24	CH32	CH40	CH48	CH56	CH64

Bi-Level Inputs with Adjustable Threshold

The 64 sensor inputs can also be used as bi-level detection inputs. The bi-level detection comparators monitor one position, simultaneously, from each of the input banks; the position is register selectable. The Bi-level MUX and the AMUX are not independent, the EN_BL SW POS bit of register 12 must be asserted to use the Bi-Level MUX. The selected eight bi-level inputs are compared to a common adjustable threshold that is developed using an 8 bit binary DAC. The outputs for the group of 8 are available in a register that is continuously updated and can be polled to monitor the status. The comparators are sampled during the clock cycle that the Bi-Level Status is read.

Differential Amplifier, Gain scaling, Anti-Aliasing Filter

The AMUX feeds directly into the inputs of an instrumentation amplifier with three selectable fixed gain settings (x0.4, x2 and x10) selectable using register 7. The Instrumentation Amplifier has a buffered output to drive the two pole anti-aliasing filter (AAF); the AAF poles can be set to 10kHz, 2kHz or 400Hz using register 7. The output of the AAF drives the ADC input. The output of the entire gain and filter stage is accessible at the ADC_IN pin. The ADC has a dynamic range of 0 to 2V and can be driven directly from the ADC_IN pin if the AAF is turned off using register 7 (AAF off) or register 8 (ADC_IN = HiZ).

The instrumentation amplifier on a gain setting of 0.4 has a relatively high slew rate; this requires a wait state for the IA output to settle for large signal level changes.

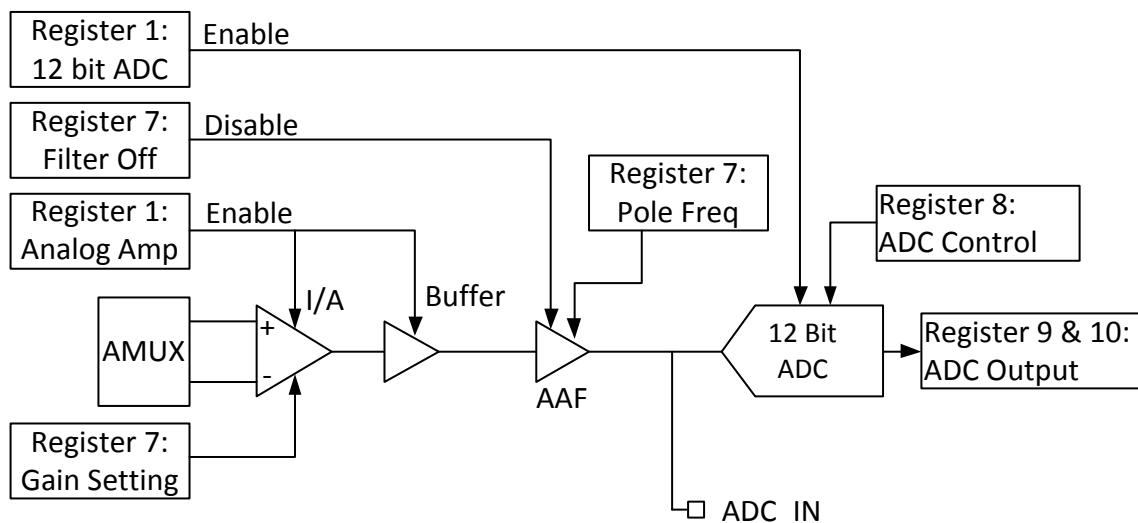

The table below indicates how to configure the amplifier and filter chain for various modes of operation.

Condition	12 bit ADC	Analog Amp	AAF off
Use entire chain: IA, buffer, AAF and ADC	on	on	on
Use ADC driven by ADC_IN	on	Don't care	off
Shut everything off to save maximum power	off	off	off

12 Bit ADC

The ADC uses a successive approximation register (SAR) design. The CLK input sequences the ADC logic.

The ADC can be set to convert continuously or to convert on request using START CONVERT. Whenever a conversion is in process the BUSY status bit is asserted. When the conversion is complete the DATA READY bit is set. The ADC value registers are updated when the DATA READY bit is asserted, but will not change during the process of a data read which starts by reading the upper byte and ends by reading the lower byte.

If the continuous conversion is selected using the Auto Conv bit of register 8, the ADC values are updated continuously whether or not the registers are read.

The specified linearity and offset error of the ADC is a result of fitting a straight line to the ADC response curve.

10-bit Current DAC

The output of the DAC should be terminated in a resistor that is less than 1.5kΩ to insure the DAC stays within its compliance range. A parallel 1nF or greater capacitor can also be used to help reduce bit change glitches. The DAC has complementary outputs that are accomplished by steering the current between the two outputs based on the DAC setting. At zero LSBs, the DAC_N is full scale and DAC_P is off. The 10-bit Current DAC positive output, DAC_P should be open circuited and the negative output DAC_N can be connected to GND if the Use_DAC bit is asserted. (See current De-Mux description.)

Current De-Mux

The current de-mux routes a programmable current to whichever of the 64 CH inputs is selected. There are several modes of operation depending on the current amplitude required. The maximum current is available when the Use_DAC bit is de-asserted and the Double_Weight bit is asserted;

this provides eight levels ranging from 500uA to 4mA. When both the Use_DAC and Double_Weight bits are de-asserted there are eight possible levels from 250uA to 2mA. If the Use_DAC bit is asserted, the 10bit DAC is used to set the de-mux current; each LSB has a weight of 10uA. A maximum of 300uA is suggested (code 31) when operating in this mode. The current de-mux can be shut off by asserting the Current Source Disable bit of register 1; the current De-MUX defaults to the off state at power up and must be enabled.

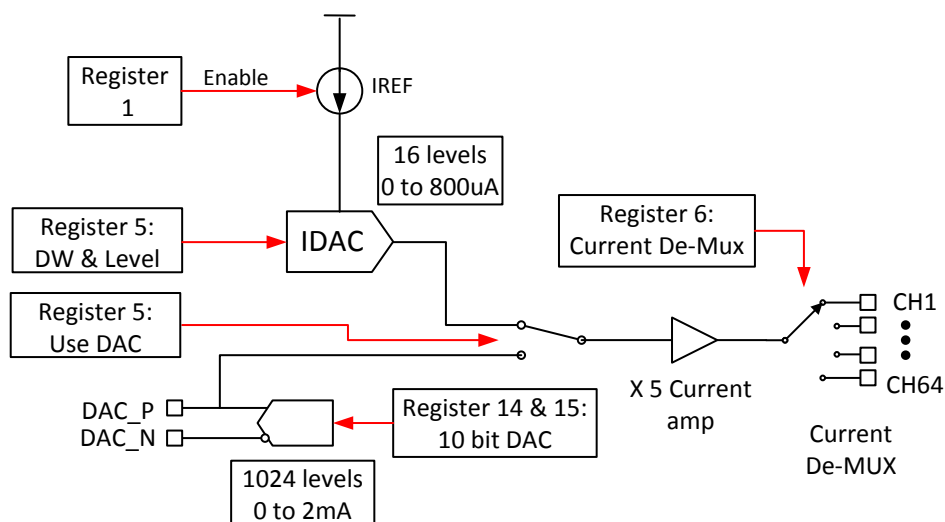

Fixed Bi-Level Inputs

There are eight fixed bi-level inputs with a 2.5V internal threshold setting common to all detectors. There is also a register selectable external threshold pin BL_TH where a threshold voltage can be programmed using a voltage divider to VREF that can be used in place of the internal reference. These logic threshold detected outputs go directly to output pins so they can be monitored directly by the FPGA without the delay of the digital interface. A low pass filter and threshold hysteresis provides high frequency noise rejection.

Power On Reset

In Manual reset mode, the FPGA logically drives the RESET pin directly. The RESET pin should be asserted and released a few milliseconds after power is applied to place the registers in the default state. In auto-reset mode, a capacitor should be connected from RESET to GND to provide SEFI immunity and to program the reset time delay: the time delay from a valid VDD and internal 5V rail within the IC until the reset is released. The equation for this timing is:

$$DELAY = 35000 \times C_{RESET}$$

FPGA Interface

There are two options provided for the FPGA interface; either a single parallel interface or two SPI interfaces. Grounding either the SPI_A or SPI_B pin will selected either of these interfaces; these pins have a 1MΩ pull-up to VDD. Only one interface can be active at any one time, but it is acceptable to switch between interfaces; this should only be done when the interface is idle or at rest. The LX7730 executes a command as soon as it has been received with the exception of the 10 bit DAC. The DAC output is updated when the upper byte MSB register is written to.

The LX7730 performs a simple even parity check on the combination of the address, data and PTY (parity) bits for parallel data and the combination of address, data, W/R and P (parity) for serial data. The W/R bit is high for a register write and low for a register read. If a parity error is discovered, the command will not execute and the /ACK pin is pulled high, see "Interface Timing" for /ACK output timing. Both SPI and parallel data transfers have even parity. The PTY line supports a parity bit for the parallel data transfers.

Interface Timing

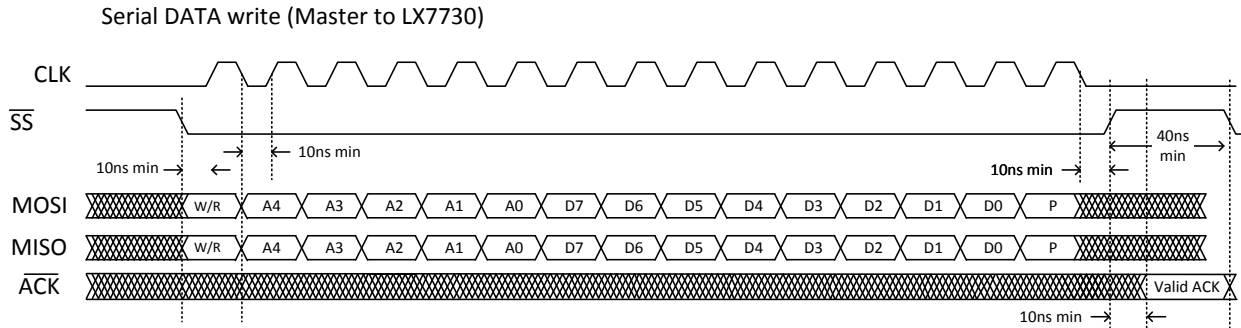

Figure 6 · Serial Data Write Timing Diagram

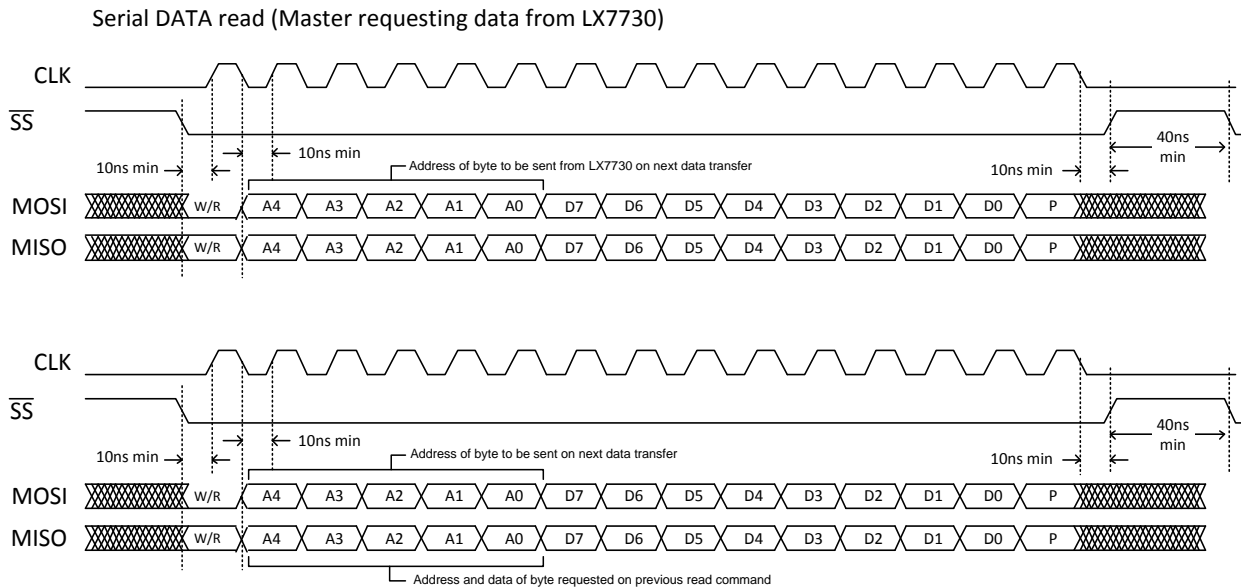
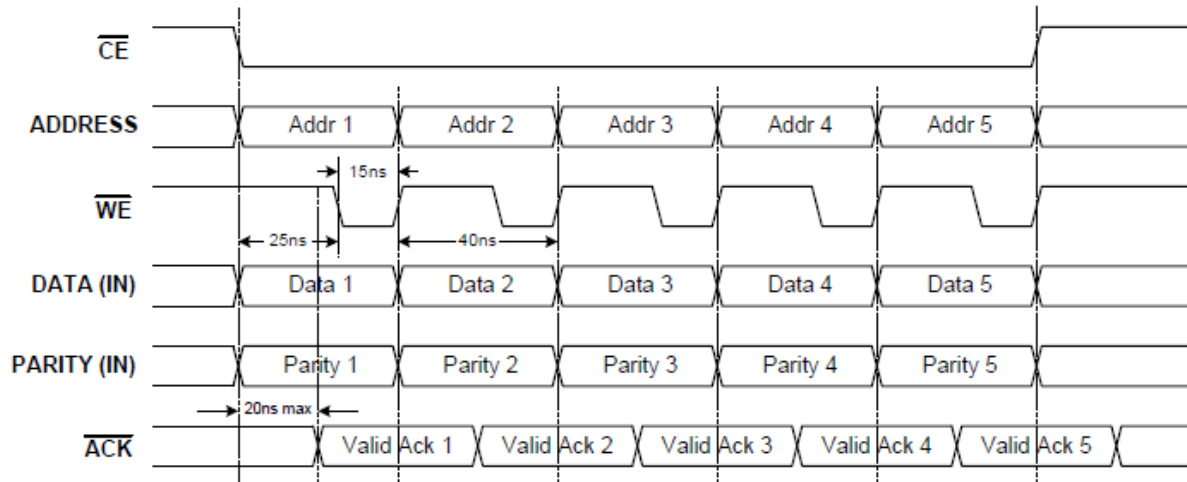

Figure 7 · Serial Data Read Timing Diagram

Parallel Write/Read Diagram (with minimum period of 40ns):

1. Successive DATA Write cycles (\overline{OE} remains high)



2. Successive DATA Read cycles (\overline{WE} remains high)

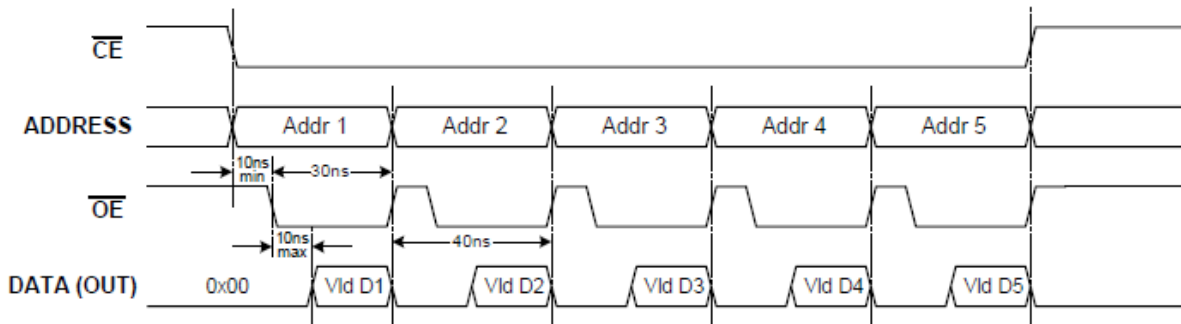

Figure 8 · Parallel Data Transfer Timing Diagram for Successive Data Transfers

Note: For “serial data write” /ACK output is valid after /SS rises. It will remain valid until the next time /SS is pulled low. For “parallel data write” the /ACK output is valid after the address, data, and PTY signals are stable. The /ACK output should be low while /CE is low for the data to be written to the registers

Register Descriptions

Register address 0: Master Reset

Register address 0 is used to perform a master reset which returns all internal registers to the power on (default) state. During the applied reset state, test signals are routed to BLO5 to 8. The mapping for this is: BLO5 = VCC UVLO, BLO6 = VEE UVLO, BLO7 = +5V UVLO, BLO8 = Power On Enable. To perform the master reset, the bit code 01101010 must be written to register 0; then, to restore normal operation a write to register 0 of another code (such as 00000000) is required.

Register address 1: Function Enable

The Function enable register provides the option to power down functions that are not used; the default would be to have everything active. The idea is to conserve power but only to the extent it can be done without affecting any of the functions that are still active.

Function Enable Register			
Bit #	Name	Default	Description
7	Chip Enable	1	If de-asserted everything but the active power supplies and digital interface to the FPGA is turned off but the internal register contents are preserved; this is a low power sleep mode. CH# and BLI# and DAC pins are cold spared. If de-asserted, functions corresponding to bits 0 thru 6 are disabled.
6	Sensor MUX	1	If de-asserted, all CH switching and routing (Analog or Bi-Level) is turned off. CH# pins are cold spared.
5	Current Source Disable	1	If asserted, the multiplexed current source directed to a CH# pin is not used and powered down. If de-asserted, the multiplexed current source is enabled and directed to the CH# defined in register 6
4	Bi-level comp	1	If de-asserted, power is removed from the bi-level comparators but doing so does not affect the functionality of the Analog Multiplexer and ADC.
3	Analog Amplifiers	1	If de-asserted, the instrumentation amplifier and buffer driving the AAF are powered down. The ADC and Bi-level comparators are not affected; however the ADC must be driven by an external signal using ADC_IN pin (with Filter Off bit asserted or ADC=Hi Z asserted).
2	10 Bit DAC	1	If de-asserted, the 10 bit DAC is not used and powered down. DAC outputs are cold spared.
1	Fixed Bi-Level	1	If de-asserted, the Fixed Bi-level converters are not used and powered down. BLI# inputs are cold spared.
0	12 Bit ADC	1	If de-asserted, the 12 bit ADC is not used and powered down.

Register address 2: Power Status

The Power Status register provides the option to check for a UVLO condition or to monitor the power rails. There is also a bit for selection of the redundant IREF pin.

Power Status Register

Bit #	Name	Default	Description
7	Use IREF2	0	If asserted, IREF2 is used to set the reference current instead of the resistor attached to IREF1.
6	Monitor VCC	0	If asserted, this action overrides the setting of the register of address 3 and routes VCC pin divided by 6 to the non-inverting terminal of the IA (instrumentation amplifier). It overrides the setting of the address 4 register and applies GND to the inverting terminal of the IA.
5	Monitor VEE	0	If asserted, this action overrides the setting of the register of address 4 and routes VEE pin divided by 6 to the inverting terminal of the IA (instrumentation amplifier). It overrides the setting of the address 3 register and applies GND to the non-inverting terminal of the IA.
4	Monitor +5V	0	If asserted, this action overrides the setting of the register of address 3 and routes +5V pin divided by 2 to the non-inverting terminal of the IA (instrumentation amplifier). It overrides the setting of the address 4 register and applies GND to the inverting terminal of the IA.
3	Monitor VREF	0	If asserted, this action overrides the setting of the register of address 3 and routes VREF pin divided by 2 to the non-inverting terminal of the IA (instrumentation amplifier). It overrides the setting of the address 4 register and applies GND to the inverting terminal of the IA.
2	VCC UVLO	0	Asserted by the LX7730 if VCC is below the UVLO threshold.
1	VEE UVLO	0	Asserted by the LX7730 if VEE is below the UVLO threshold.
0	+5V UVLO	0	Asserted by the LX7730 if the +5V is below the UVLO threshold.

Register address 3: Non-Inverting MUX Channel Select

The Non-Inverting MUX Channel Select register is used to select the CH# pin that is routed by the analog MUX to the non-inverting pin of the Instrumentation amplifier.

Non-Inverting MUX Channel Select Register

Bit #	Name	Default	Description
6 - 7	Not Used	0	
5	Bank D2	0	These 6 bits are used to select an input channel. Bits 3 to 5 are used to select the bank and bits 0 to 2 are used to select the position. The conversion of bank/position to CH# follows this equation: $CH\# = (\text{Reg } [2:0] \times 8) + \text{Reg } [5:3] + 1$ For example to route CH11 to the non-inverting terminal of the instrumentation amplifier, the value in register 3 would be 00-010-001.
4	Bank D1	0	
3	Bank D0	0	
2	Position D2	0	
1	Position D1	0	
0	Position D0	0	

Register address 4: Inverting MUX Channel Select

The Inverting MUX Channel Select register is used to select the CH# pin that is routed by the analog MUX to the inverting pin of the Instrumentation amplifier. There is also a bit (Use SE_RTN, bit 6, that when asserted, overrides the value determined by bits D5 to D0 and instead of selecting an CH# pin, connects the SE_RTN input pin to the inverting pin of the instrumentation amplifier.

Inverting MUX Channel Select Register			
Bit #	Name	Default	Description
7	Not Used	0	
6	Use SE_RTN	0	If asserted, this bit routes the SE_RTN pin to the inverting terminal of the instrumentation amplifier.
5	Bank D2	0	These 6 bits are used to select an input channel. Bits 3 to 5 are used to select the bank and bits 0 to 2 are used to select the position. The conversion of bank/position to CH# follows this equation: $CH\# = (\text{Reg } [2:0] \times 8) + \text{Reg } [5:3] + 1$ For example to route CH11 to the inverting terminal of the instrumentation amplifier, the value in register 3 would be 00-010-001.
4	Bank D1	0	
3	Bank D0	0	
2	Position D2	0	
1	Position D1	0	
0	Position D0	0	

Register address 5: Current MUX Level

The Current MUX level register is used to set the current in the programmable current source. Only the lower four LSBs are used since there are only sixteen possible levels. Bit 3, when asserted, doubles the current source reference current which doubles the weight of each output current setting.

Current De-MUX Level Register			
Bit #	Name	Default	Description
7	Use DAC	0	When asserted the 10 bit DAC is used to program the current for the current De-Mux. The current output will be 5 X the 10 bit DAC DAC_P output. The DAC_P output will also be disabled. (1)
4 - 6	Not Used	0	Not Used
3	Double Weight	0	When asserted, this bit doubles the weight of the current source as determined by bits D2 to D0.
2	D2 (MSB)	0	These 3 bits are used to select the amplitude of the programmable current source. Their binary value (BV) represents a number from 0 to 7. If bit D3 is not asserted, the current source output is $(BV + 1) \times 250\mu\text{A}$. If bit D3 is asserted the current source output is $2 \times (BV+1) \times 250\mu\text{A}$.
1	D1	0	
0	D0 (LSB)	0	

(1) DAC_N should still have an impedance of 1.5KΩ or less to ground

Register address 6: Current MUX Channel Selection

The Current MUX Select register is used to route the current source to one of the 64 input channels (CH#).

Current MUX Channel Selection Register

Bit #	Name	Default	Description
6 - 7	Not Used	0	Not Used
5	D5 (MSB)	0	These 6 bits are used to select an input channel. Their binary value represents a number from 0 to 63. The CH# pin selected is their binary value plus 1. For example value D5 to D0 = 011011, or binary 27 will route the output of the programmable current source to CH28.
4	D4	0	
3	D3	0	
2	D2	0	
1	D1	0	
0	D0 (LSB)	0	

Register address 7: Signal Conditioning Amplifier

The Signal Conditioning Amplifier register controls the gain and pole location for the signal conditioning amplifier located between the output of the instrumentation amplifier and the input to the ADC. It can be shut off to facilitate bypassing or using external signal.

Signal Conditioning Amplifier Register

Bit #	Name	Default	Description
7	Not Used	0	Not Used
6	AAF off	0	If de-asserted (and ADC=HiZ is also de-asserted) , the AAF amplifier is fully functional and the output of the AAF drives the ADC input with a low impedance driver. When asserted, the AAF filter is off and the ADC can be driven from ADC_IN.
5	Second Pole Frequency MSB	0	These two pins are used to select the pole frequency for a single pole response for one of two possible single pole filters. The frequency settings are [D5, D4] = 00, 01, 10 for 400, 2k, 10k in Hertz, respectively (setting 11 is not used).
4	Second Pole Frequency LSB	0	
3	First Pole Frequency MSB	0	These two pins are used to select the pole frequency for a single pole response for one of two possible single pole filters. The frequency settings are [D3, D2] = 00, 01, 10 for 400, 2k, 10k in Hertz, respectively (setting 11 is not used).
2	First Pole Frequency LSB	0	
1	Gain Setting MSB	0	These two pins are used to select the gain setting for the amplifier channel. The gain settings are [D1,D0] = 00, 01, 10 for a gain of 0.4, 2.0, or 10. The [D1,D0] = 11 setting is not used (but also sets a gain of 10).
0	Gain Setting LSB	0	

Register address 8: Analog to Digital Converter Control

The ADC Converter Control register allows the FPGA to initiate a sampling or continuous sampling. It also indicates the status of the ADC.

Analog to Digital Converter Control Register

Bit #	Name	Default	Description
7	Auto Sample Rate	0	This register is used to slow down the auto sample rate of the ADC. The auto sample rate is set to multiples of the Sample Period (t_{SAMP}). The register bits 7, 6, 5 represent a binary value "N" with bit 7 representing the MSB. This 3 bit binary value sets the ADC auto sample rate = $t_{SAMP} \times 2^N$.
6		0	
5		0	
4	Auto Conv	0	If asserted, the ADC performs continuous conversions. ADC conversions are stored until the next value is ready and then overwritten.
3	Data Ready	0	This bit is asserted by the LX7730 when the ADC finishes a conversion and stays asserted until Start Conv is asserted or the Auto Conv timer begins another conversion.
2	Busy	0	This bit is asserted by the LX7730 while the ADC is performing a conversion.
1	Start Conv	0	If asserted, this bit starts a single conversion process of the ADC.
0	ADC_IN = HI_Z	0	If de-asserted (and AAF off is also de-asserted) , the AAF amplifier is fully functional and the output of the AAF drives the ADC input with a low impedance driver. When asserted, the AAF filter is off and the ADC can be driven from ADC_IN.

Register address 9: ADC Upper Byte

The ADC Upper Byte register contains the most significant eight bits from the last completed ADC conversion.

ADC Upper Byte

Bit #	Name	Default	Description
7	D11 (MSB)	0	Eight most significant bits from last completed ADC conversion. The combined ADC output from registers 9 and 10 represents a value that is 12 bits long. From the ADC input, the ADC value represents: $([12 \text{ bit value}] / 4095) \times 2.0$
6	D10	0	
5	D9	0	
4	D8	0	
3	D7	0	
2	D6	0	
1	D5	0	
0	D4	0	

Register address 10: ADC Lower Bits

The ADC Lower Bits register contains the least significant four bits from the last completed ADC conversion.

ADC Lower Bits

Bit #	Name	Default	Description
4 - 7	Not Used	0	Not Used
3	D3	0	Four least significant bits from last completed ADC conversion. The combined ADC output from registers 9 and 10 represents a value that is 12 bits long. From the ADC input, the ADC value represents: $([\text{12 bit value}]/4095) \times 2.0$
2	D2	0	
1	D1	0	
0	D0 (LSB)	0	

Register address 11: Bi Level Threshold DAC

The Bi Level Threshold DAC register contains the digital value that controls the 8 bit Digital to Analog converter output.

Bi Level Threshold DAC Register

Bit #	Name	Default	Description
7	D7 (MSB)	0	Eight bits for setting the Bi-Level Threshold. The Bi-Level Threshold level is: $([\text{Reg 11 value}]/255) \times 5V$
6	D6	0	
5	D5	0	
4	D4	0	
3	D3	0	
2	D2	0	
1	D1	0	
0	D0 (LSB)	0	

Register address 12: Bi-Level Bank Switch Position and Fixed Bi-Level Optional Input

The Bi-Level Bank Switch Position register selects one of the eight switch positions from the eight banks of inputs to be routed to the eight Bi-Level comparators. The fixed Bi-Level inputs (not related to the Bi-Level Banks) has an optional external threshold setting input which can be selected using the MSB of this register.

Bi-Level Bank Switch Position and Fixed Bi-Level Optional Input Register

Bit #	Name	Default	Description
7	Use BL-TH	0	Asserting this bit selects the external BL_TH pin for the Fixed Bi-Level inputs.
4 - 6	Not Used	0	Not Used
3	En BL Sw Pos	0	Asserting this bit enable the selection of the Bi-Level Bank Switch Position.
2	D2 (MSB)	0	These 3 bits are used to select a common switch position for the eight bi-level multiplexers. The binary value represents a number from 0 to 7. The switch position selected is their binary value plus 1. For example value [D2, D1, D0] = 011, or binary 3 will select switch position 4 or route CH25 to CH32 to the bi-level comparators.
1	D1	0	
0	D0 (LSB)	0	

Register address 13: Bi-Level Status

The Bi-Level status register has a bit dedicated to each threshold comparator output. The bit is asserted if the selected CH# channel voltage is greater than the reference as determined by the Bi-Level Threshold DAC register.

Bi-Level Status Register

Bit #	Name	Default	Description
7	Comparator 8	0	Comparator for channels: $([REG\ 12]+1) \times 8$
6	Comparator 7	0	Comparator for channels: $\{([REG\ 12]+1) \times 8\} - 1$
5	Comparator 6	0	Comparator for channels: $\{([REG\ 12]+1) \times 8\} - 2$
4	Comparator 5	0	Comparator for channels: $\{([REG\ 12]+1) \times 8\} - 3$
3	Comparator 4	0	Comparator for channels: $\{([REG\ 12]+1) \times 8\} - 4$
2	Comparator 3	0	Comparator for channels: $\{([REG\ 12]+1) \times 8\} - 5$
1	Comparator 2	0	Comparator for channels: $\{([REG\ 12]+1) \times 8\} - 6$
0	Comparator 1	0	Comparator for channels: $\{([REG\ 12]+1) \times 8\} - 7$

Register address 14: 10 Bit DAC Upper Byte

The 10 Bit DAC Upper Byte register contains the upper eight most significant bits for the digital value that controls the outputs of the 10 Bit Current Digital to Analog converter.

10 Bit DAC Upper Byte

Bit #	Name	Default	Description
7	D7 (MSB)	0	Eight most significant bits for setting the outputs of the 10 Bit Current DAC. Combined with the two least significant bits from register 15, this makes up a 10 bit value. The Current DAC output currents are (with R _{ref} = 20k): $DAC_P = ([10\ \text{Bit value}] / 1023) \times 2\text{mA}$ $DAC_N = [1 - ([10\ \text{Bit value}] / 1023)] \times 2\text{mA}$ When the upper byte is written, both the upper byte and lower byte are changed to the values stored in registers 14 and 15.
6	D6	0	
5	D5	0	
4	D4	0	
3	D3	0	
2	D2	0	
1	D1	0	
0	D0 (LSB)	0	

Register address 15: 10 Bit DAC Lower Bits

The 10 Bit DAC Lower Byte register contains the two least significant bits for the digital value that controls the outputs of the 10 Bit Current Digital to Analog.

10 Bit DAC Lower Bits Register

Bit #	Name	Default	Description
2 - 7	Not used	0	Not Used
1	D1	0	Two least significant bits for setting the outputs of the 10 Bit Current DAC. Combined with the eight most significant bits from register 14, this makes up a 10 bit value. The Current DAC output currents are (with R _{ref} = 20k): $DAC_P = ([10\ \text{Bit value}] / 1023) \times 2\text{mA}$ $DAC_N = [1 - ([10\ \text{Bit value}] / 1023)] \times 2\text{mA}$ The lower byte is not loaded until the upper byte register is written.
0	D0 (LSB)	0	

Register address 16: Calibration

The Calibration register is used to perform calibration of the amplifier offset and FPGA assisted testing of the multiplexer switches and programmable current source multiplexer.

Calibration Register			
Bit #	Name	Default	Description
7	IA Short	0	If asserted, this action overrides the setting of the register of address 4 and causes a switch closure which shorts the inverting terminal of the instrumentation amplifier to the non-inverting terminal.
6	Not used	0	
5	Not used	0	
4	Cont Check	0	If asserted, a current source is applied to the non-inverting input of the instrumentation amplifier.
3	NP Cont Check	0	If asserted, a current source is applied to the inverting input of the instrumentation amplifier and the non-inverting terminal is connected to VREF.
2	Not used	0	
1	I GND	0	If asserted, this action overrides the setting of the register of address 4 and causes a switch closure which shorts the inverting terminal of the instrumentation amplifier to IC GND.
0	Not Used	0	

Register address 17: OTP

The OTP register enables the user to read the default OTP bits and adjusts the bits as required.

Power and Reference Adjust Register			
Bit #	Name	Default	Description
2 - 7	Not Used	0	Not Used
1	OTP out select	0	If this bit is asserted the OTP outputs will be set by registers 18 through 22. If this bit is not asserted the OTP will out be set by internal programming bits
0	OTP in select	0	If this bit is asserted the default OTP bits are read into register 18 through 22.

Built-In Test and Adjustment Features

The following test features allow for checking and adjusting the LX7730.

Amplifier and Filter Offset calibration: The combined amplifier offset voltage as measured at ADC_IN can be varied from the factory trimmed value by using bits 3 to 0 of register 19 in calibration mode. The resultant offset effect can be monitored using the ADC.

AMUX and testing: A functional continuity check is performed asserting the CONT CHECK register; this routes the adjustable current source directly to the non-inverting pin of the IA. (See figure #10) Current flows out of the AMUX to the selected CH# input pin. If the current encounters an open circuit in the AMUX or at the CH# pin, the voltage at the IA non-inverting pin will clamp. If the external sensor is properly attached, the voltage read by the ADC will include the impedance of the sensor plus the impedance of the two AMUX switches encountered in the current path. In CONT CHECK mode, selecting the same CH# for the inverting and non-inverting terminals also allows the P-polarity MUX impedance to be measured.

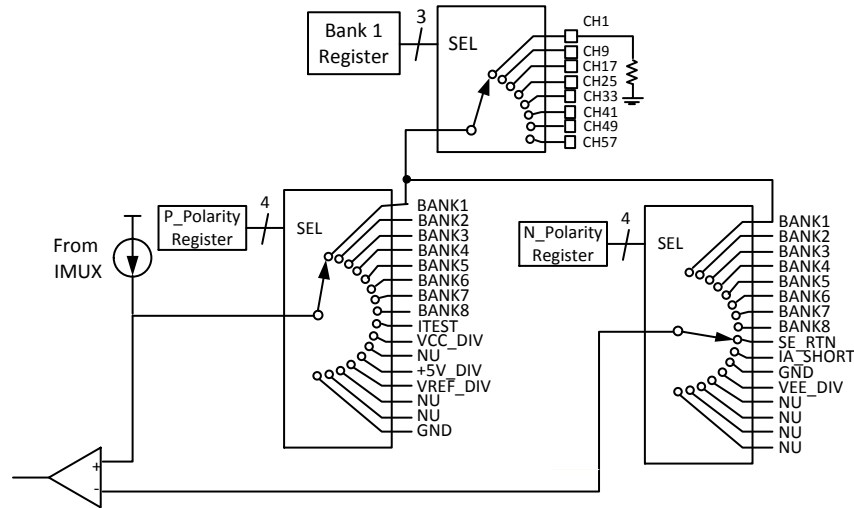

Figure 9 · Non-Inverting AMUX Continuity Check Test Configuration

A functional continuity check of the Inverting terminal MUX is performed asserting the NP_TEST register bit; this routes the adjustable current source directly to the inverting pin of the IA. (See figure #11) Current flows out of the AMUX to the selected Inverting MUX CH# input pin. If the current encounters an open circuit in the AMUX or at the CH# pin, the voltage at the IA pin will clamp. The Non-inverting terminal is connected to VREF_DIV for this test. If the external sensor is properly attached, the voltage read by the ADC is the difference of VREF_DIV and the product of the current source and the impedance of the sensor plus the impedance of the two AMUX switches encountered in the current path. The impedance of the NP_MUX can be calculated once the other impedances are known using the CONT CHECK.

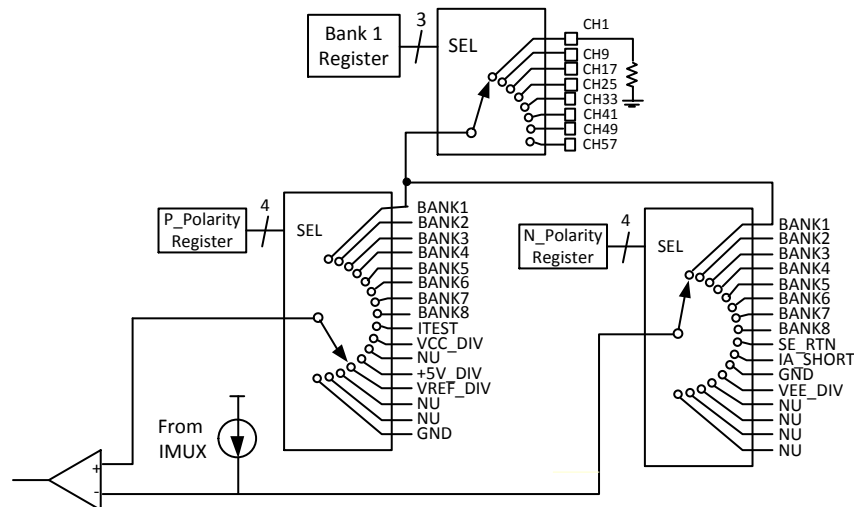
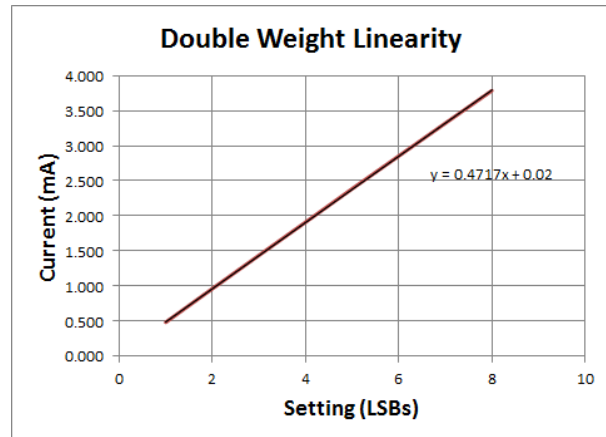
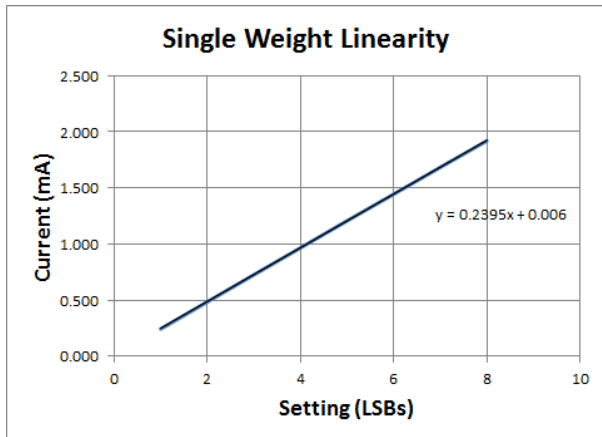
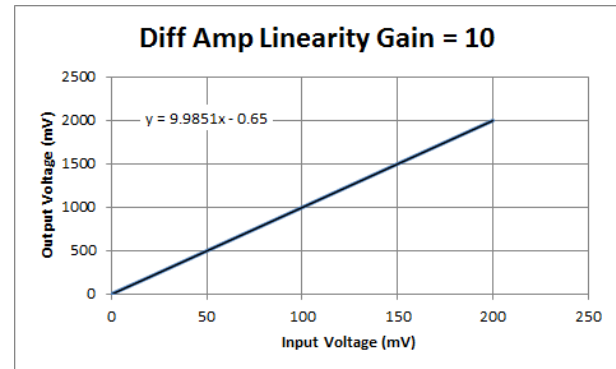
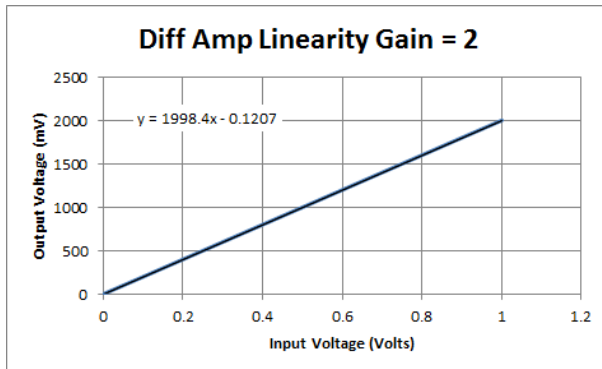
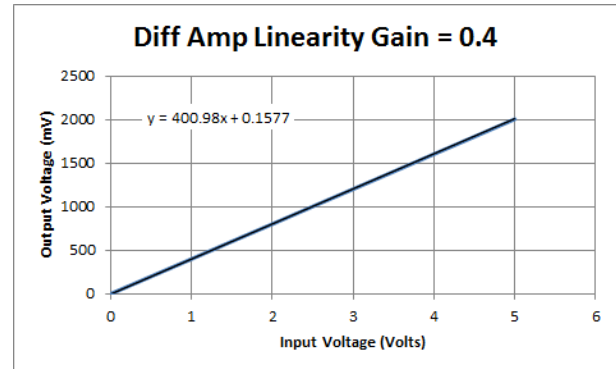
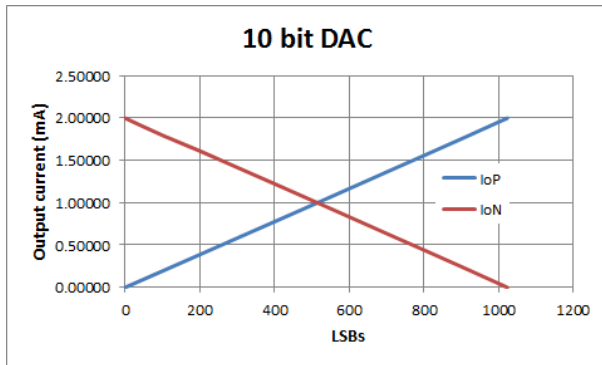
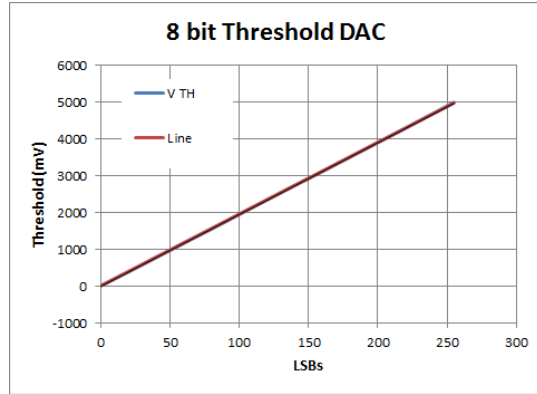
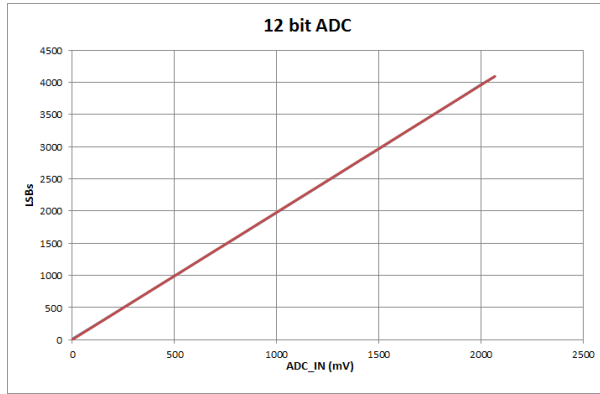

Figure 10 · Inverting AMUX Continuity Check Test Configuration

Power supply Monitoring: The power supply pins for the LX7730 can be monitored by selecting special calibration registers: MON VCC, MON VEE, MON +5V, MON VREF. The voltages are divided down by a factor of 6 for the 15V rails and a factor of 2 for the 5V and VREF pins. Because VREF is also the reference for the ADC, VREF must be monitored relative to a known external voltage such as VCC or an external voltage reference if using the ADC for monitoring.

Power Supply Adjusting: It is possible to adjust the VREF output using register 18 bits 4 to 0. Adjustment of VREF will affect all functions that are referencing VREF including IREF.

Characteristic Curves



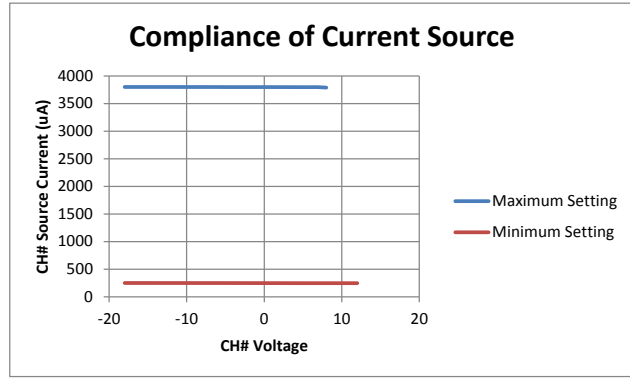
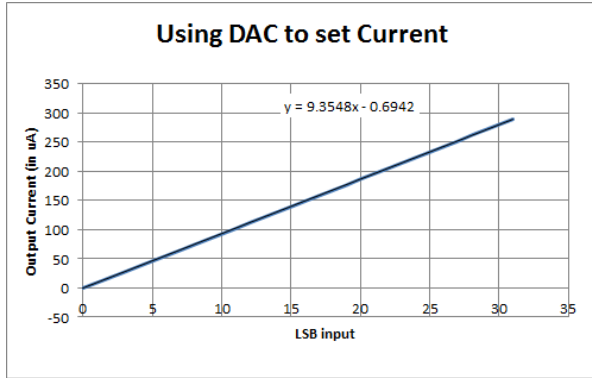

Ceramic Quad Flat Pack Outline Dimensions

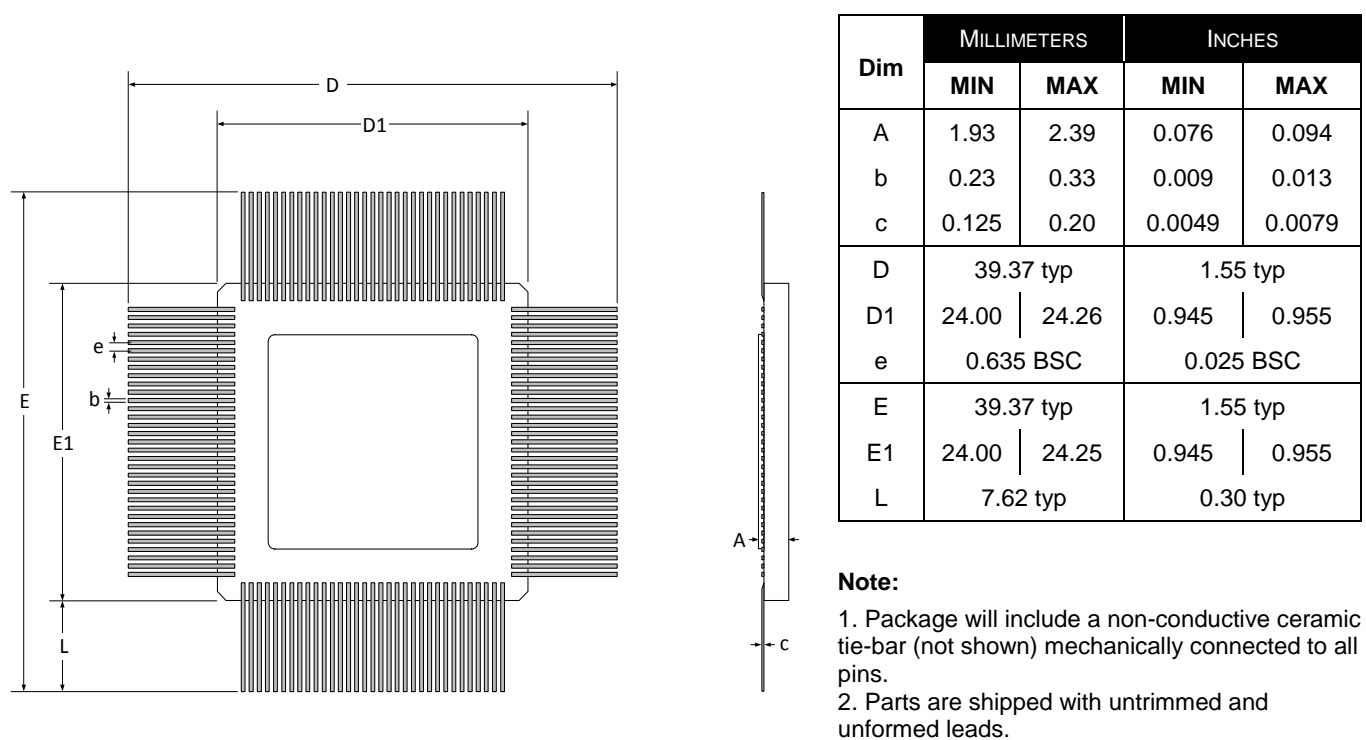

Figure 11 • Package Dimensions



Microsemi Corporate Headquarters

One Enterprise, Aliso Viejo,
CA 92656 USA

Within the USA: +1 (800) 713-4113

Outside the USA: +1 (949) 380-6100

Sales: +1 (949) 380-6136

Fax: +1 (949) 215-4996

E-mail: sales.support@microsemi.com

© 2015 Microsemi Corporation. All rights reserved. Microsemi and the Microsemi logo are trademarks of Microsemi Corporation. All other trademarks and service marks are the property of their respective owners.

Microsemi Corporation (Nasdaq: MSCC) offers a comprehensive portfolio of semiconductor and system solutions for communications, defense & security, aerospace and industrial markets. Products include high-performance and radiation-hardened analog mixed-signal integrated circuits, FPGAs, SoCs and ASICs; power management products; timing and synchronization devices and precise time solutions, setting the world's standard for time; voice processing devices; RF solutions; discrete components; security technologies and scalable anti-tamper products; Power-over-Ethernet ICs and midspans; as well as custom design capabilities and services. Microsemi is headquartered in Aliso Viejo, Calif., and has approximately 3,400 employees globally. Learn more at www.microsemi.com.

Microsemi makes no warranty, representation, or guarantee regarding the information contained herein or the suitability of its products and services for any particular purpose, nor does Microsemi assume any liability whatsoever arising out of the application or use of any product or circuit. The products sold hereunder and any other products sold by Microsemi have been subject to limited testing and should not be used in conjunction with mission-critical equipment or applications. Any performance specifications are believed to be reliable but are not verified, and Buyer must conduct and complete all performance and other testing of the products, alone and together with, or installed in, any end-products. Buyer shall not rely on any data and performance specifications or parameters provided by Microsemi. It is the Buyer's responsibility to independently determine suitability of any products and to test and verify the same. The information provided by Microsemi hereunder is provided "as is, where is" and with all faults, and the entire risk associated with such information is entirely with the Buyer. Microsemi does not grant, explicitly or implicitly, to any party any patent rights, licenses, or any other IP rights, whether with regard to such information itself or anything described by such information. Information provided in this document is proprietary to Microsemi, and Microsemi reserves the right to make any changes to the information in this document or to any products and services at any time without notice.