

# DATA SHEET

Part No.	AN16996A
Package Code No.	QFN044-P-0606C

Maintenance/Discontinued

Maintenance/Discontinued includes following four Product lifecycle stage.  
(planned maintenance type, maintenance type, planned discontinued type, discontinued type)

Contents

- Overview ..... 3
- Features ..... 3
- Applications ..... 3
- Package ..... 3
- Type ..... 3
- Application Circuit Example ..... 4
- Block Diagram ..... 5
- Pin Descriptions ..... 6
- Absolute Maximum Ratings ..... 8
- Operating Supply Voltage Range ..... 8

Maintenance/Discontinued  
(planned maintenance type, maintenance type, planned discontinued type, discontinued type)  
Maintenance/Discontinued includes following four Product lifecycle stage.

# AN16996A

## VIF/SIF IC for Car TV Receivers

### ■ Overview

The AN16996A is a VIF/SIF signal-processing IC for use in car TV receivers. It adopts a split carrier system that completely separates video and audio processing and includes soft muting, SD, and other circuits required for car TV use. It provides superb performance in addition to its extensive functionality.

### ■ Features

- Split carrier audio detection circuit
- Field detection and bandwidth detection soft muting and SD circuits
- Pseudo-synchronous detection strongly resistant to field strength fluctuations is used in the VIF circuit
- Video output pin for diversity detection (no noise inverter required)
- Supports FM audio reception (function that turns off the VIF system)

### ■ Applications

- Car TV

### ■ Package

- 44-pin plastic quad flat non-leaded package (QFN type)

### ■ Type

- Silicon monolithic bipolar IC

Maintenance/Discontinued  
(planned maintenance type, maintenance type, planned discontinued type, discontinued type)  
Maintenance/Discontinued includes following four Product lifecycle stage.

Application Circuit Example

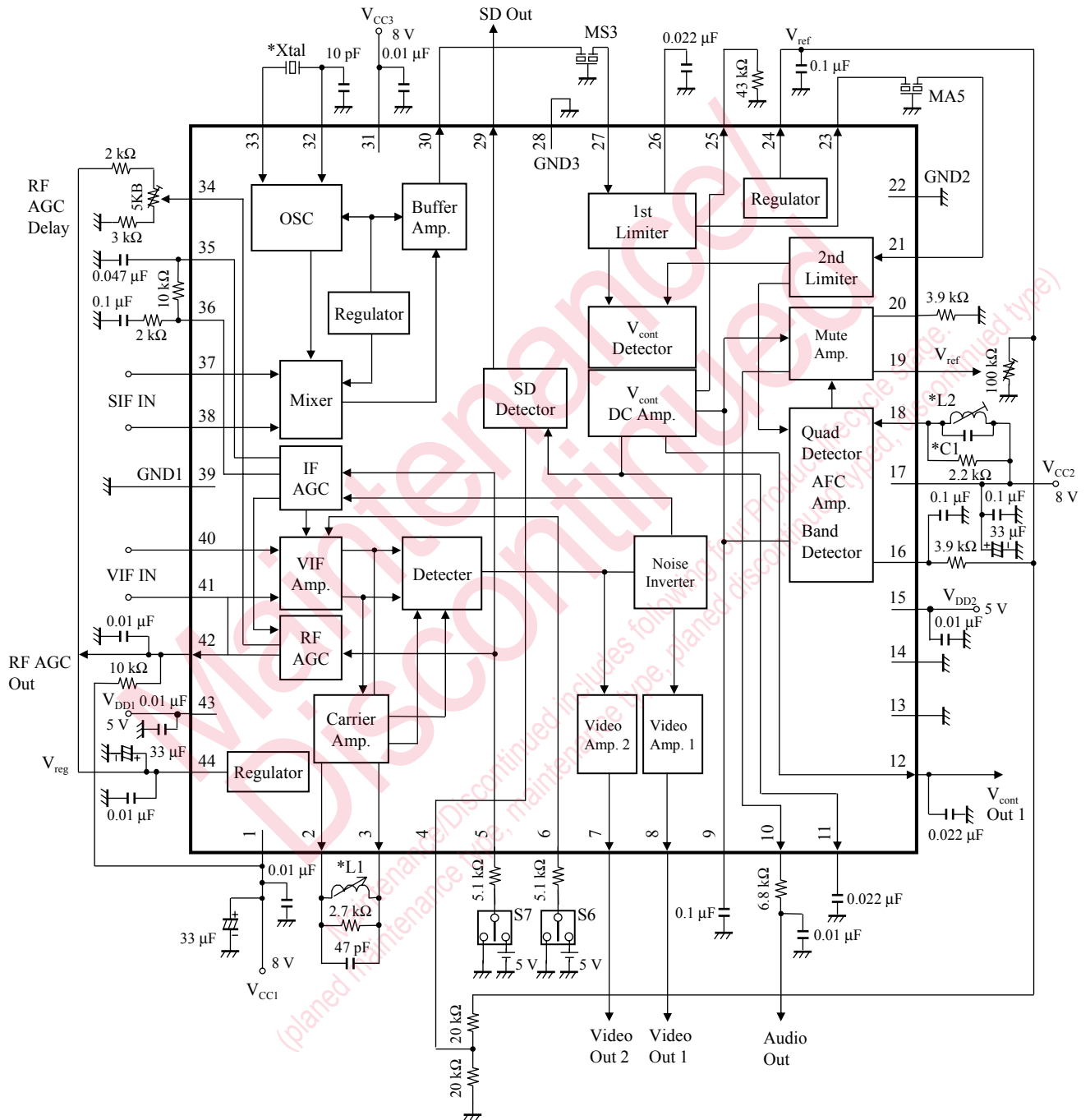



## ■ Pin Descriptions

Pin No.	Pin name	Type	Description
1	V <sub>CC1</sub>	Power supply	V <sub>CC1</sub>
2	LC1	Out	VIF detection coil 1
3	LC2	Out	VIF detection coil 2
4	SSC	Out	SD detection adjustment
5	AGCSW	In	AGC switch
6	VIFSW	In	VIF switch
7	VIDEOOUT2	Out	Video output 2
8	VIDEOOUT1	Out	Video output 1
9	SMTC	Out	Muting voltage
10	AUDIOOUT	Out	Audio output
11	VASC	Out	ASC S-meter voltage
12	VCONOUT	Out	S-meter voltage
13	DMON	In	Test pin
14	RMON	In	Test pin
15	V <sub>DD2</sub>	Power supply	V <sub>DD2</sub>
16	AFCOUT	Out	AFC output
17	V <sub>CC2</sub>	Power supply	V <sub>CC2</sub>
18	QUADIN	In	SIF detection coil
19	SMA1	Out	Soft muting start point adjustment
20	SMA2	Out	Soft muting slope adjustment
21	2NDIFIN	In	Second limiter input
22	GND2	Ground	Ground 2
23	SIFLIMOUT	Out	First limiter output
24	VREF	Out	SIF reference voltage
25	VCONADJ	Out	S-meter voltage adjustment
26	IFAB	Out	First limiter bypass
27	IFIN	In	First limiter input
28	GND3	Ground	Ground 3
29	SDOUT	Out	SD output
30	MIXOUT	Out	Mixer output
31	V <sub>CC3</sub>	Power supply	V <sub>CC3</sub>
32	OSC1	In	OSC 1
33	OSC2	In	OSC 2
34	AGCDLY	Out	RF AGC delay adjustment
35	IFAGC1	Out	IF AGC output

## ■ Pin Descriptions (continued)

Pin No.	Pin name	Type	Description
36	IFAGC2	In	IF AGC input
37	SIFIN1	In	SIF input 1
38	SIFIN2	In	SIF input 2
39	GND1	Ground	Ground 1
40	VIFIN1	In	VIF input 1
41	VIFIN2	In	VIF input 2
42	RFAGCOUT	Out	RF AGC output
43	V <sub>DD1</sub>	Power supply	V <sub>DD1</sub>
44	VREG	Out	VIF reference voltage

Maintenance/Discontinued

Maintenance/Discontinued includes following four Product lifecycle stage.  
(planned maintenance type, maintenance type, planned discontinued type, discontinued type)

### ■ Absolute Maximum Ratings

A No.	Parameter	Symbol	Rating	Unit	Notes
1	Supply voltage	$V_{CC1}$	9.0	V	*1
		$V_{CC2}$	9.0		
		$V_{CC3}$	9.0		
		$V_{DD1}$	6.2		
		$V_{DD2}$	6.2		
2	Supply current	$I_{CC}$	—	A	—
3	Power dissipation	$P_D$	229	mW	*2
4	Operating ambient temperature	$T_{opr}$	-30 to +85	°C	*3
5	Storage temperature	$T_{stg}$	-55 to +150	°C	*3

Notes) \*1 : The values under the condition not exceeding the above absolute maximum ratings and the power dissipation.

\*2 : The power dissipation shown is the value at  $T_a = 85^\circ\text{C}$  for the independent (unmounted) IC package with out a heat sink.

\*3 : Except for the power dissipation, operating ambient temperature, and storage temperature, all ratings are for  $T_a = 25^\circ\text{C}$ .

### ■ Operating supply voltage range

Parameter	Symbol	Rangs	Unit	Notes
Supply voltage range	$V_{CC1}$	7.2 to 8.8	V	*
	$V_{CC2}$	7.2 to 8.8		
	$V_{CC3}$	7.2 to 8.8		
	$V_{DD1}$	4.6 to 5.5		
	$V_{DD2}$	4.6 to 5.5		

Note) \* : The values under the condition not exceeding the above absolute maximum ratings and the power dissipation.

## Request for your special attention and precautions in using the technical information and semiconductors described in this book

- (1) If any of the products or technical information described in this book is to be exported or provided to non-residents, the laws and regulations of the exporting country, especially, those with regard to security export control, must be observed.
- (2) The technical information described in this book is intended only to show the main characteristics and application circuit examples of the products, and no license is granted under any intellectual property right or other right owned by our company or any other company. Therefore, no responsibility is assumed by our company as to the infringement upon any such right owned by any other company which may arise as a result of the use of technical information described in this book.
- (3) The products described in this book are intended to be used for standard applications or general electronic equipment (such as office equipment, communications equipment, measuring instruments and household appliances).  
Consult our sales staff in advance for information on the following applications:
  - Special applications (such as for airplanes, aerospace, automobiles, traffic control equipment, combustion equipment, life support systems and safety devices) in which exceptional quality and reliability are required, or if the failure or malfunction of the products may directly jeopardize life or harm the human body.
  - Any applications other than the standard applications intended.
- (4) The products and product specifications described in this book are subject to change without notice for modification and/or improvement. At the final stage of your design, purchasing, or use of the products, therefore, ask for the most up-to-date Product Standards in advance to make sure that the latest specifications satisfy your requirements.
- (5) When designing your equipment, comply with the range of absolute maximum rating and the guaranteed operating conditions (operating power supply voltage and operating environment etc.). Especially, please be careful not to exceed the range of absolute maximum rating on the transient state, such as power-on, power-off and mode-switching. Otherwise, we will not be liable for any defect which may arise later in your equipment.
  - Even when the products are used within the guaranteed values, take into the consideration of incidence of break down and failure mode, possible to occur to semiconductor products. Measures on the systems such as redundant design, arresting the spread of fire or preventing glitch are recommended in order to prevent physical injury, fire, social damages, for example, by using the products.
- (6) Comply with the instructions for use in order to prevent breakdown and characteristics change due to external factors (ESD, EOS, thermal stress and mechanical stress) at the time of handling, mounting or at customer's process. When using products for which damp-proof packing is required, satisfy the conditions, such as shelf life and the elapsed time since first opening the packages.
- (7) This book may be not reprinted or reproduced whether wholly or partially, without the prior written permission of Matsushita Electric Industrial Co., Ltd.