



M82720 GRAPHICS DISPLAY CONTROLLER

Military

- Displays Low-to-High Resolution Images
- Draws Characters, Points, Lines, Arcs, and Rectangles
- Supports Monochrome, Gray Scale, or Color Displays
- Zooms, Pans and Windows Through a 4 Mpixel Display Memory
- Extremely Flexible Programmable Screen Display, Blanking, and Sync Formats
- Compatible with Intel's Microprocessor Families
- High-Level Commands Off Load Host Processor from Bit Map Loading and Screen Refresh Tasks
- Supports Graphics, Character, and Mixed Display Modes
- Military Temperature Range: -55°C to +125°C (Tc)
- HMOS* III Processing Technology

The M82720 Graphics Display Controller (GDC) is an intelligent microprocessor peripheral designed to drive high-performance raster-scan computer graphics and character CRT displays. Positioned between the video display memory and Intel microprocessor bus, the GDC performs the tasks needed to generate the raster display and manage the display memory. Processor software overhead is minimized by the GDC's sophisticated instruction set, graphics figure drawing, and DMA transfer capabilities. The display memory directly supported by the GDC can be configured in any number of formats and sizes up to 256K 16-bit words. The display can be zoomed and partitioned screen areas can be independently scrolled and panned. With its light pen input and multiple controller capability, the GDC is ideal for most computer graphics applications. Systems implemented with the GDC can be designed to be compatible with standards such as VDI, NAPLPS, GKS, Core, or custom implementations.

This product has been end-of-lifed. Please refer to the M82786 for all new designs.

*HMOS is a patented process of Intel Corporation.

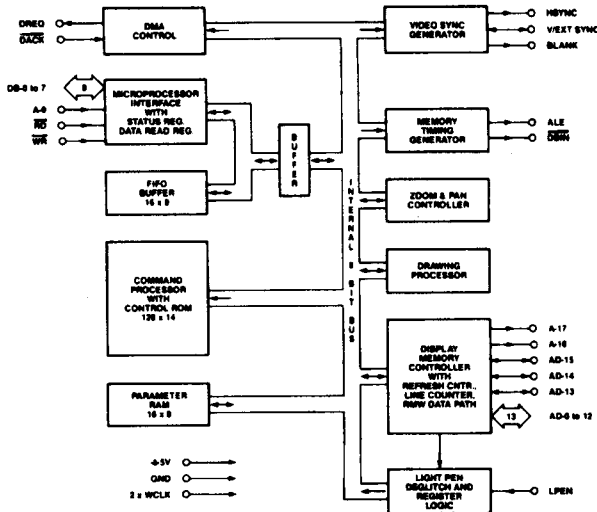
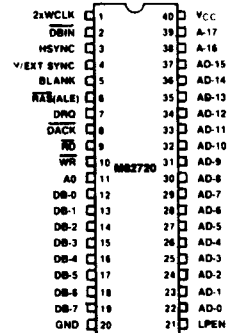

Figure 1. Block Diagram

271037-1



271037-2

Figure 2. Pin Configuration