

DESCRIPTION

The MSC-LX1790 offers a patent pending, low voltage, low power, and high efficiency amplifier for driving a hearing aid receiver. It comes with three programmable gain settings of 14dB, 20dB and 26dB.

The MSC-LX1790 also comes with three output switch resistance settings to accommodate different receivers. It is delivered in bare die form.

KEY FEATURES

- Low Operating Current: 100µA Typical
- Low Operating Voltage: 0.9V minimum
- 3 Gain Settings: 14, 20 & 26dB
- 3 Output Switch Resistance Settings: 48, 24 & 16 Ω
- Small Form Factor: 2.03mm² Bare die

APPLICATIONS

- Hearing Aid

IMPORTANT: For the most current data, consult MICROSEMI's website: <http://www.microsemi.com>

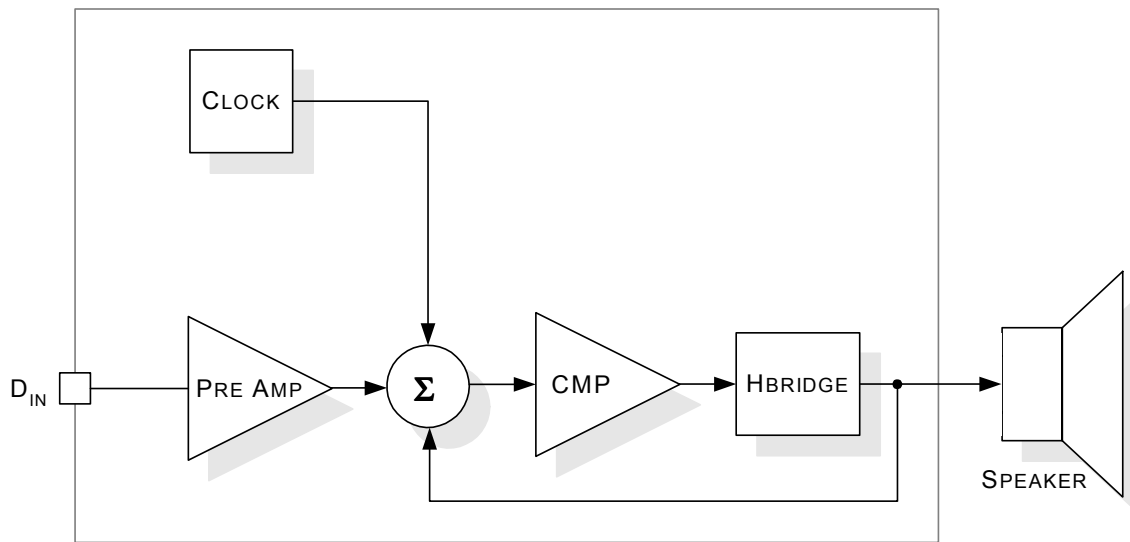
PRODUCT HIGHLIGHT

Simplified Block Diagram

PACKAGE ORDER INFO

T _J (°C)	J Ceramic Dip 14 -Pin	LM Plastic MLPM 8-Pin	BD Bare Die 7-Pin
10 to 55	LX1790CJ	LX1790LM (*)	LX1790BD

(*) Contact factory for availability

**Low Voltage, Low Power, AudioMite™
 Class-D Audio Amplifier**
DATASHEET
ABSOLUTE MAXIMUM RATINGS

Input Logic Supply Voltage (V_{DD}) -0.3V to +3.0V
 Operating Temperature Range..... 10°C to 55°C

Note: Exceeding these ratings could cause damage to the device. All voltages are with respect to Ground. Currents are positive into, negative out of specified terminal.

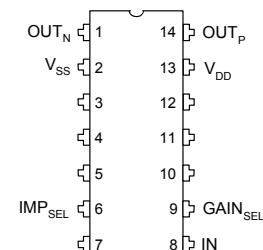
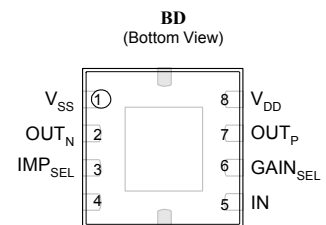
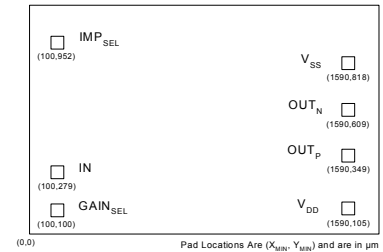
PACKAGE PIN OUT

FUNCTIONAL PIN DESCRIPTION

PIN NAME	PIN No 8 PIN LM	PIN No 14 PIN J	DESCRIPTION
V_{DD}	8	13	Supply Voltage
V_{SS}	1	2	Ground
IN	5	8	Analog Audio Input
OUT _P	7	14	Positive Output Voltage
OUT _N	2	1	Negative Output Voltage
GAIN _{SEL}	6	9	Gain Select. See Settings table below for selections.
IMP _{SEL}	3	6	Output Resistance Select. See Settings table below for selections.

SETTINGS

PIN	GAIN _{SEL} =VDD IMP _{SEL} =VSS	GAIN _{SEL} =VSS IMP _{SEL} =VDD	GAIN _{SEL} =Floating IMP _{SEL} =Floating
GAIN _{SEL}	14dB	20dB	26dB
IMP _{SEL}	16Ω	24Ω	48Ω

RECOMMENDED OPERATING CONDITIONS

Parameter	Symbol	Test Conditions	LX1790			Units
			Min	Typ	Max	
▶ OPERATING CONDITIONS						
Supply Voltage	V _{DD}		0.9		1.5	V
Ground	V _{SS}			0		V

ELECTRICAL CHARACTERISTICS

Unless otherwise specified, the following specifications apply over the operating ambient temperature T_A=25°C except where otherwise noted. Test conditions: V_{DD}=1.3V, V_{SS}=0V, R_{LOAD}=200Ω in Series with 60mH

Parameter	Symbol	Test Conditions	LX1790			Units
			Min	Typ	Max	
Switch Output Resistance @ Low Drive	R _{OUT-L}			48		Ω
Switch Output Resistance @ Med Drive	R _{OUT-M}			24		
Switch Output Resistance @ High Drive	R _{OUT-HI}			16	19	
Quiescent Current @ Low Drive	IDDQ _L			100		μA
Quiescent Current @ Med Drive	IDDQ _M			110		
Quiescent Current @ High Drive	IDDQ _H			120		
3dB Bandwidth – mid Frequency	F _{MIN}	All gain settings		40	100	Hz
3dB Bandwidth – max Frequency	F _{MAX}		20			KHz
Output Switching Frequency		F _{CLK}		200		KHz
Gain Setting 1	A ₁	V _{IN} = 100mV _{RMS} @ 1KHz	12	14	16	dB
Gain Setting 2	A ₂	V _{IN} = 50mV _{RMS} @ 1KHz	18	20	22	dB
Gain Setting 3	A ₃	V _{IN} = 25mV _{RMS} @ 1KHz	24	26	28	dB
Power Supply Rejection Ratio	PSRR	Input Reference		45		dB
Total Harmonic Distortion @ Gain = 14dB	THD ₁₄	V _{IN} = 50mV _{RMS} @ 1KHz		0.3		%
Total Harmonic Distortion @ Gain = 20dB	THD ₂₀	V _{IN} = 25mV _{RMS} @ 1KHz		0.3		%
Total Harmonic Distortion @ Gain = 26dB	THD ₂₆	V _{IN} =12mV _{RMS} @ 1KHz		0.3		%
Input Referred Noise	V _{N-14}	Gain = 14dB, 100Hz – 10Khz, A-Weighted		20		μV
Input Referred Noise	V _{N-20}	Gain = 20dB, 100Hz – 10Khz, A-weighted		10		μV
Input Referred Noise	V _{N-26}	Gain = 26dB, 100Hz – 10Khz, A-weighted		6		μV
Input Resistance	R _{IN-14}	Gain = 14dB		120		K Ω
Input Resistance	R _{IN-20}	Gain = 20dB		83		K Ω
Input Resistance	R _{IN-26}	Gain = 26dB		53		K Ω
Output clock frequency	F _{CLK}		140	200	300	KHz
DC Offset OutN-OutP	V _{OFF-NP}	No input signal	-5	0	5	mV

CHARTS

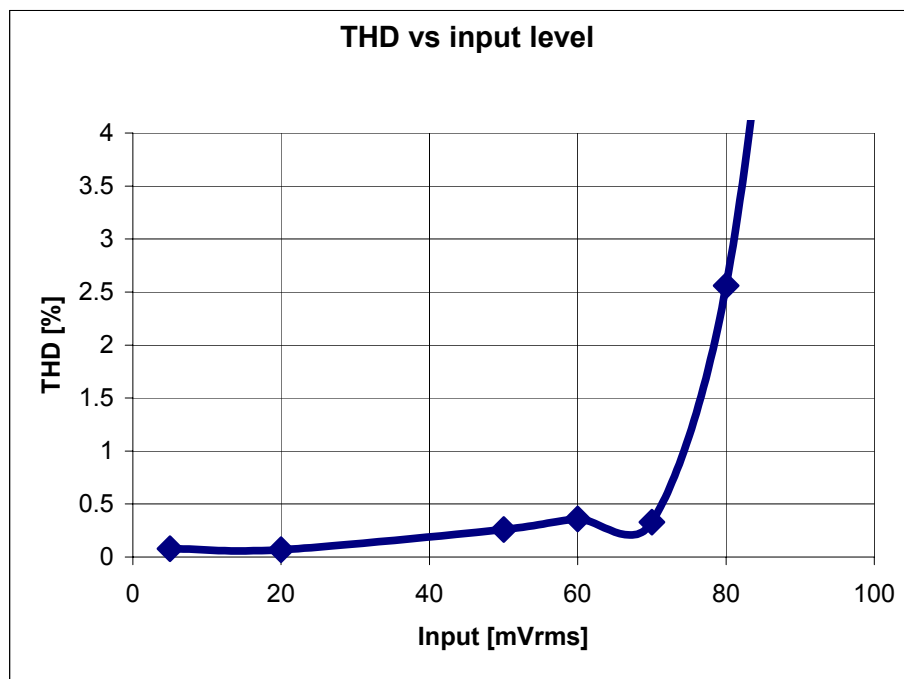

Figure 1 – THD vs. Input Level FIN = 1kHz, Gain = 20dB (Note: clip level at 90mVrms)

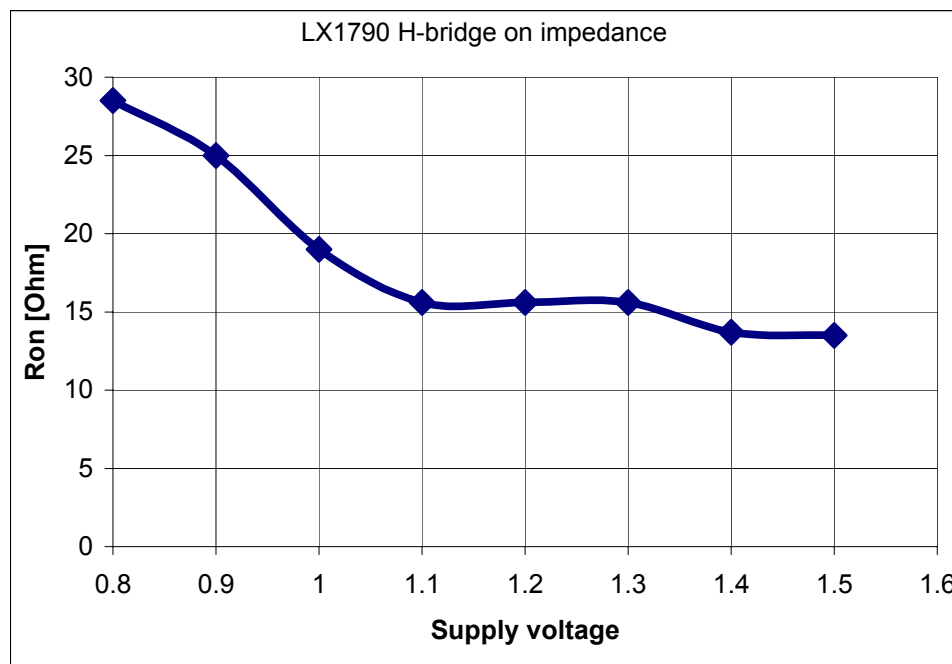
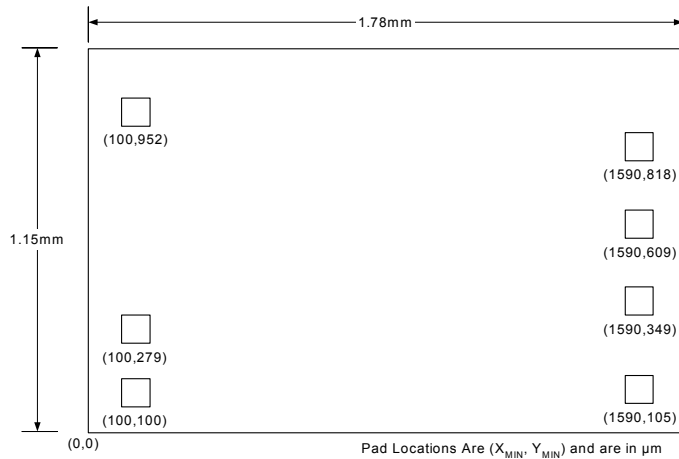
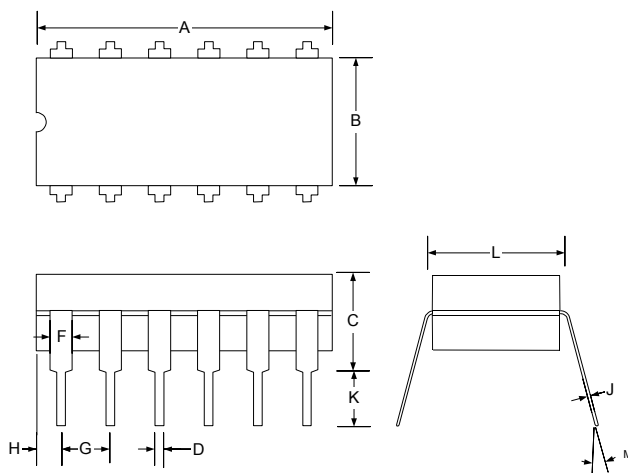

Figure 2 – H-Bridge Impedance vs. Supply Voltage (Lowest Impedance Setting)

MECHANICALS
BD 7-Pin Bare Die

Dim	MILLIMETERS		INCHES	
	MIN	MAX	MIN	MAX
X		1.15		0.045
Y		1.78		0.070
Z	0.190	0.216	0.0075	0.0085

J 14-Pin Ceramic Dip

Dim	MILLIMETERS		INCHES	
	MIN	MAX	MIN	MAX
A	19.30	19.94	0.760	0.785
B	5.59	7.11	0.220	0.280
C	-	5.08	-	0.200
D	0.38	0.51	0.015	0.020
F	1.02	1.77	0.040	0.070
G	2.54 BSC		0.100 BSC	
H	-	2.03	-	0.080
J	0.20	0.38	0.008	0.015
K	3.17	5.08	0.125	0.200
L	7.37	7.87	0.290	0.310
M	-	15°	-	15°

Note:

- Dimensions do not include mold flash or protrusions; these shall not exceed 0.155mm(.006") on any side. Lead dimension shall not include solder coverage.

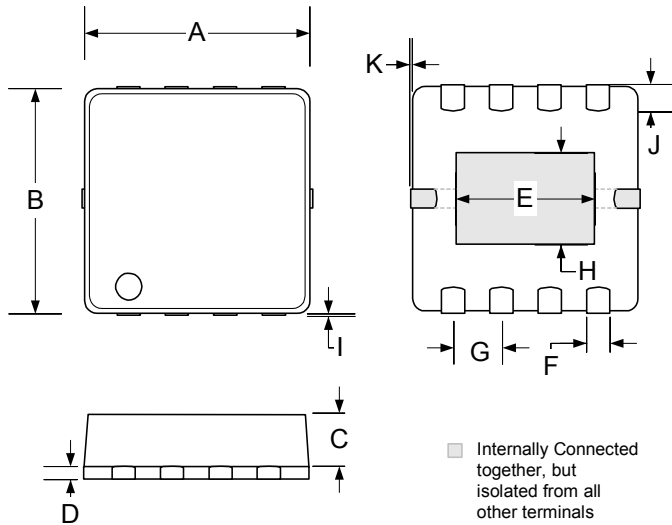
MECHANICALS
LM 8-Pin Plastic MLP-Micro Exposed Pad

Dim	MILLIMETERS		INCHES	
	MIN	MAX	MIN	MAX
A	2.90	3.10	0.114	0.122
B	2.90	3.10	0.114	0.122
C	0.65	0.75	0.025	0.029
D	0.15	0.25	0.005	0.009
E	1.841 BSC		0.075 BSC	
F	0.27	0.43	0.010	0.016
G	0.65 BSC		0.025 BSC	
H	1.22 BSC		0.048 BSC	
I	0	0.10	0	0.003
J	0.21	0.37	0.008	0.014
K	0	0.10	0	0.003

Note:

- Dimensions do not include mold flash or protrusions; these shall not exceed 0.155mm(.006") on any side. Lead dimension shall not include solder coverage.



NOTES