

Product name VG-4231CA 10.000000 MHz DRC-T  
 Product code / Ordering code Q3614CA001192xx

Please refer to the 8.Packing information about xx (last 2 digits)

Output waveform CMOS

Pb free / Complies with EU RoHS directive

Reference weight Typ.153mg

### 1.Absolute maximum ratings

Parameter	Symbol	Min.	Typ.	Max.	Unit	Conditions / Remarks
Maximum supply voltage	Vcc-GND	-0.3	-	+7	V	-
Storage temperature	T_stg	-55	-	+125	°C	Storage as single product after unpacking.
Input voltage	Vin	-0.3	-	Vcc+0.3	V	Vc traminial

### 2.Specifications(characteristics)

Parameter	Symbol	Min.	Typ.	Max.	Unit	Conditions / Remarks
Output frequency	f0		10.0000		MHz	
Supply voltage	Vcc	3	3.3	3.6	V	-
Control voltage	Vc	0.15	1.65	3.15	V	Vc=1.65V+/-1.5V
Operating temperature	T_use	-20	-	+70	°C	-
Frequency tolerance	f_tol	-35	-	+35	x10 <sup>-6</sup>	T_Use
Current consumption	Icc	-	-	10	mA	no load
Disable current	I_dis	-	-	7	mA	OE=GND
Frequency control range	f_cont	+/-130	-	-	x10 <sup>-6</sup>	-
Absolute pull range	APR	+/-80	-	-	x10 <sup>-6</sup>	-
Modulation characteristics	BW	-	20	-	kHz	+/-3dB
Input resistance	Rin	50	-	-	kΩ	-
Frequency change polarity	-					Positive Polarity
Symmetry	SYM	40	-	60	%	50% Vcc level
Output voltage	VOH	Vcc-0.4	-	-	V	50%Vcc Level
	VOL	-	-	0.4	V	-
Output load condition	L_CMOS	-	-	15	pF	-
Input voltage	VIH	70%Vcc	-	-	V	-
	VIL	-	-	30%Vcc	V	-
Rise time	tr	-	-	4	ns	20%Vcc to 80%Vcc level
Fall time	tf	-	-	4	ns	20%Vcc to 80%Vcc level
Start-up time	t_str	-	-	10	ms	t=0 at 90%Vcc
Jitter	t <sub>DJ</sub>	-	TBD	-	ps	Deterministic Jitter
	T <sub>RJ</sub>	-	TBD	-	ps	Random Jitter
	t <sub>RMS</sub>	-	TBD	-	ps	δ(RMS of total distribution)
	t <sub>p-p</sub>	-	TBD	-	ps	Peak to Peak
	t <sub>acc</sub>	-	TBD	-	ps	Accumulated Jitter(δ) n=2 to 50000 cycles
Phase jitter	tPJ	-	-	TBD	ps	Off set Frequency: 12kHz to 20MHz
Frequency aging	f_aging	-10	-	10	x10 <sup>-6</sup>	25°C,10years

### 3. Timing chart

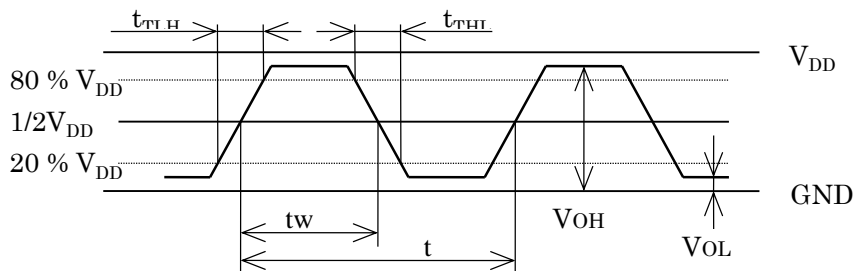

### 4. Test circuit

1) C-MOS load  $CL=15\text{ pF}$

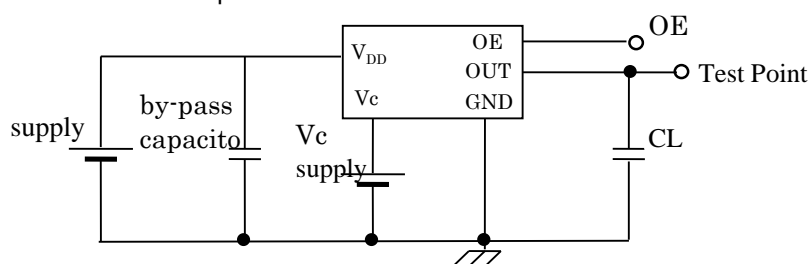

2) Current consumption

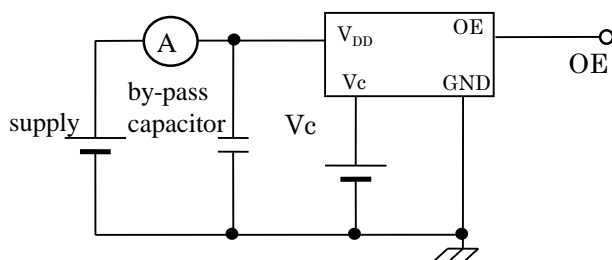

\*Current consumption under the disable function should be  $OE=GND$

3) Condition

- Oscilloscope : Impedance Min. 1 M $\Omega$   
Input capacitance Max. 15 pF  
Band width Min. 400 MHz  
Impossible to measure both frequency and wave form at the same time.  
(In case of using oscilloscope's amplifier output, possible to measure both at the same time.)
- CL includes probe capacitance.
- By-pass capacitor (0.01 mF to 0.1 mF) is placed closely between  $V_{DD}$  and GND.
- Use the current meter whose internal impedance value is small.
- Power Supply
  - Start up time (0 %  $V_{DD}$   $\rightarrow$  90 %  $V_{DD}$ ) of power source should be more than 150 ms.
  - Impedance of power supply should be as lowest as possible.
- One point earth of test circuit is required.

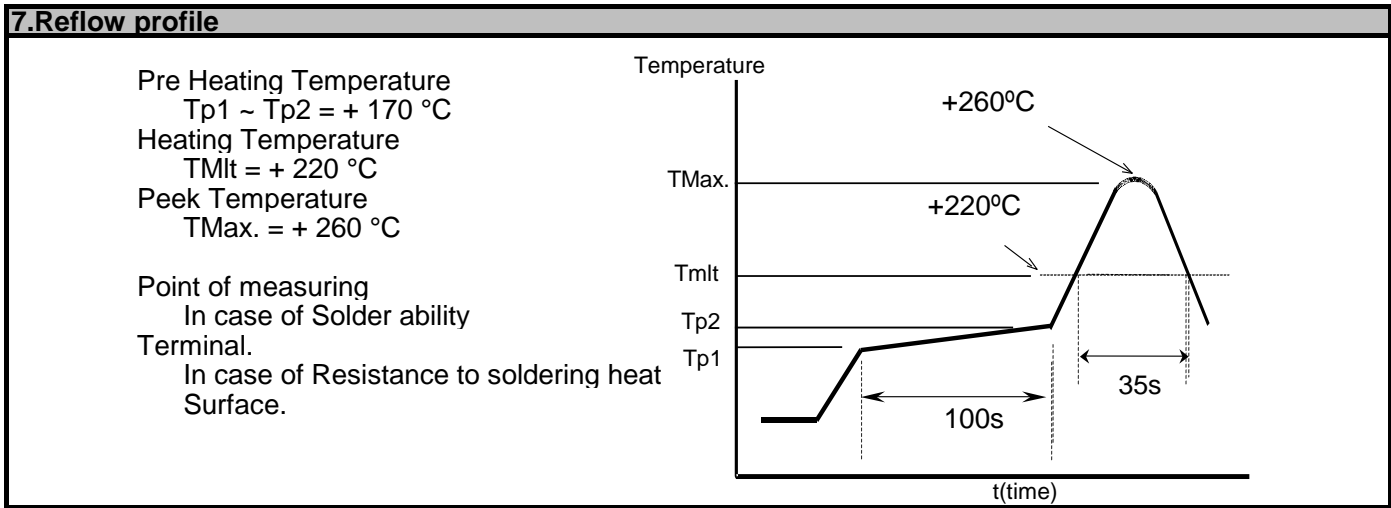
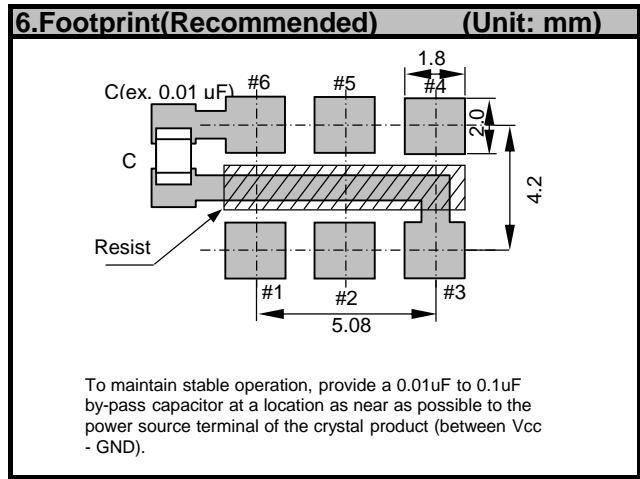
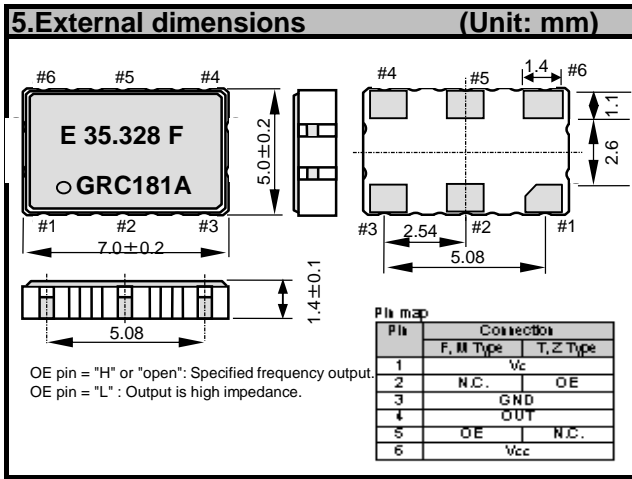

### 8.Packing information

[ 1 ] Product number last 2 digits code(xx) description      The recommended code is "00"

Q3614CA001192xx

Code	Condition	Code	Condition
00	1000pcs / Reel	11	Any Q'ty / Reel
01	Any Q'ty vinyl bag(Tape cut)	12	250pcs / Reel
02	Tube	13	500pcs / Reel

[ 2 ] Taping specification

Subject to EIA-481 & IEC-60286

(1) Tape dimensions

Material of the Carrier Tape : PS

Material of the Top Tape : PET+PE

Unit: mm

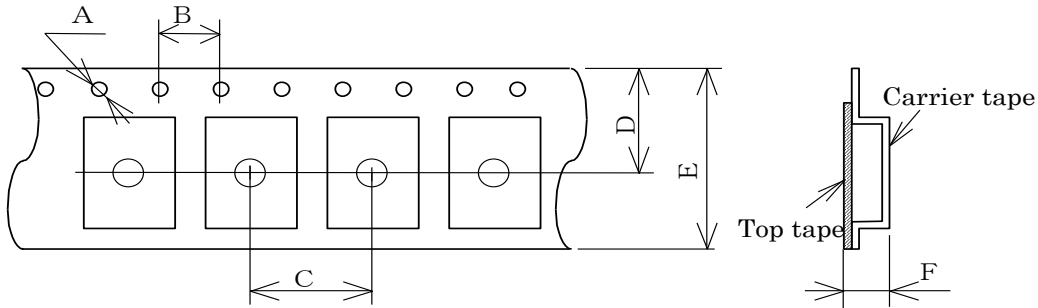

Symbol	A	B	C	D	E	F
Value	Φ1.5	4	8	9.25	16	2.3

(2) Reel dimensions

Center material : PS

Material of the Reel : PS

Unit: mm

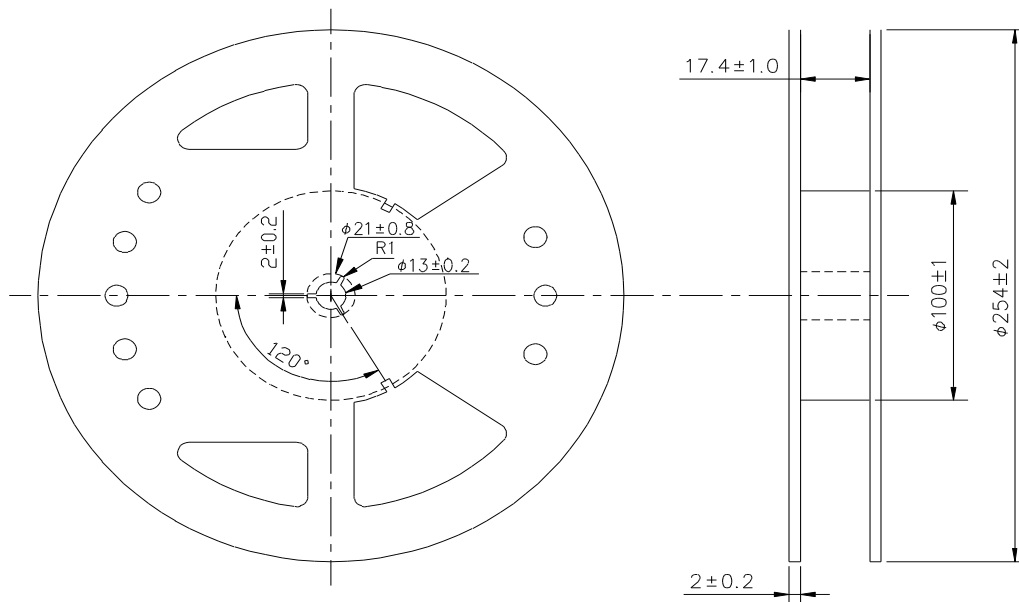

## 9. Notice

- This material is subject to change without notice.
- Any part of this material may not be reproduced or duplicated in any form or any means without the written permission of Seiko Epson.
- The information about applied circuitry, software, usage, etc. written in this material is intended for reference only. Seiko Epson does not assume any liability for the occurrence of infringing on any patent or copyright of a third party. This material does not authorize the licensing for any patent or intellectual copyrights.
- When exporting the products or technology described in this material, you should comply with the applicable export control laws and regulations and follow the procedures required by such laws and regulations.
- You are requested not to use the products (and any technical information furnished, if any) for the development and/or manufacture of weapon of mass destruction or for other military purposes. You are also requested that you would not make the products available to any third party who may use the products for such prohibited purposes.
- These products are intended for general use in electronic equipment. When using them in specific applications that require extremely high reliability, such as the applications stated below, you must obtain permission from Seiko Epson in advance.
  - / Space equipment (artificial satellites, rockets, etc.)
  - / Transportation vehicles and related (automobiles, aircraft, trains, vessels, etc.)
  - / Medical instruments to sustain life
  - / Submarine transmitters
  - / Power stations and related
  - / Fire work equipment and security equipment
  - / Traffic control equipment
  - / And others requiring equivalent reliability.
- All brands or product names mentioned herein are trademarks and/or registered trademarks of their respective.

## 10. Contact us

<http://www5.epsondevice.com/en/contact/>