

FEATURES

- Miniature 62-pin ceramic package
- 12-Bit resolution, 50kHz throughput
- Full-scale input range from 50mV to 10V
- Three-state outputs
- 16 S.E. or 8 differential input channels
- Auto-sequencing channel addressing
- MIL-STD-883 versions
- No missing codes



GENERAL DESCRIPTION

Using thin and thick-film hybrid technology, DATEL offers complete low-cost data acquisition systems with superior performance and reliability.

The HDAS-8 (with 8 differential input channels) and the HDAS-16 (with 16 single-ended input channels) are complete, high-performance, 12-bit data acquisition systems in 62-pin packages. Each HDAS may be expanded up to 32 single-ended or 16 differential channels by adding external multiplexers.

Internal channel address sequencing is automatic after each conversion, or the user may supply external channel addresses.

Internal HDAS circuitry includes:

- Analog input multiplexer (16 S.E. or 8 diff.)
- Resistor-programmable instrumentation amplifier
- Sample-and-hold circuit complete with MOS hold capacitor
- 10 Volt buffered reference
- 12-bit A/D converter with three-state outputs and control logic

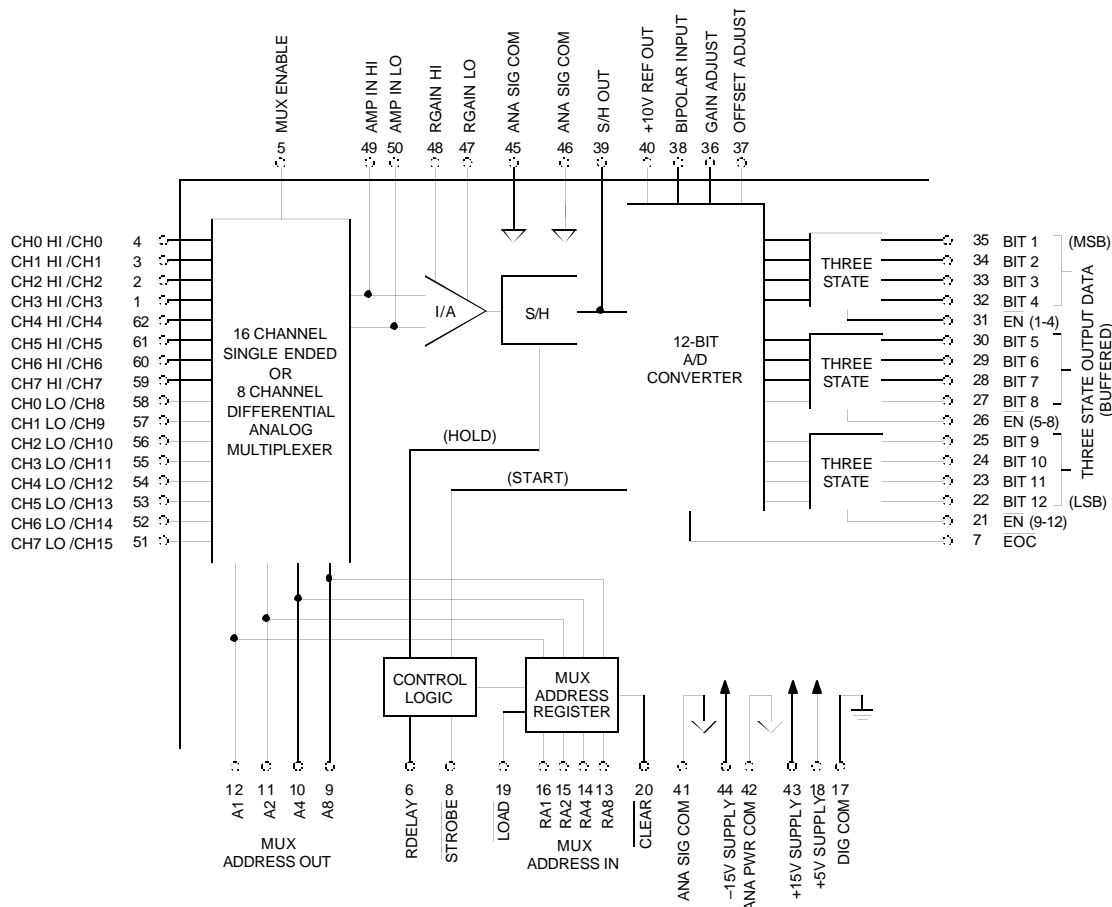

Figure 1. HDAS-16 and HDAS-8 Functional Block Diagram

ABSOLUTE MAXIMUM RATINGS

PARAMETERS	MIN.	TYP.	MAX.	UNITS
+15V Supply (pin 43)	-0.5	—	+18	Volts
-15V Supply (pin 44)	+0.5	—	-18	Volts
+5V Supply (pin 18)	-0.5	—	+7	Volts
Analog Inputs ①	-35	—	+35	Volts
Digital Inputs	-0.5	—	+7	Volts
Thermal Resistances:				
Junction-Case	—	—	15	°C/Watt
Case-Ambient	—	—	15	°C/Watt
Junction-Ambient	—	—	30	°C/Watt
Lead Temp. (10 seconds)	—	—	300	°C

FUNCTIONAL SPECIFICATIONS

(The following specifications apply over the operating temperature range and power supply range unless otherwise indicated.)

ANALOG INPUTS	MIN.	TYP.	MAX.	UNITS
Signal Range, Unipolar				
Gain = 1	0	—	+10	Volts
Gain = 200	—	—	+50	mV
Signal Range, Bipolar				
Gain = 1	-10	—	+10	Volts
Gain = 200	-50	—	+50	mV
Input Gain Equation ②	Gain = 1 + (20kΩ/RGAIN)			
Gain Equation Error	—	—	±0.1	%
Instrumentation Amplifier				
Input Impedance	10 ⁸	10 ¹²	—	Ohms
Input Bias Current:				
+25°C	—	—	±250	pA
-55 to +125°C	Doubles every 10°C			
Input Offset Current:				
+25°C	—	—	±1	nA
-55 to +125°C	Doubles every 10°C			
Multiplexer				
Channel ON Resistance	—	—	2	kΩ
Channel OFF Input Leakage	—	±30	—	pA
Channel OFF Output Leakage	—	±1	—	nA
Channel ON Leakage	—	±100	—	pA
Input Capacitance				
HDAS-16, Channel ON	—	100	—	pF
HDAS-8, Channel ON	—	50	—	pF
+25°C, Channel OFF	—	5	—	pF
Input Offset Voltage				
Gain = 1, +25°C	—	—	±2	mV
-55 to +125°C (max.)	(±3ppm/°C x Gain) ±20ppm/°C			
Gain = 200, +25°C	—	—	±100	mV
-55 to +125°C (max.)	(±3ppm/°C x Gain) ±20ppm/°C			
Common Mode Range	±10	—	—	Volts
CMRR, Gain = 1, at 60Hz	70	82	—	dB
Input Voltage Noise, Gain = 1 (Referred to input)	—	150	200	μVrms
Channel Crosstalk	—	—	-80	dB
PERFORMANCE				
Resolution	12	—	—	Bits
Integral Nonlinearity				
0 to +70°C	—	—	±1	LSB
-55 to +125°C	—	—	±1	LSB
Differential Nonlinearity				
0 to +70°C	—	—	±1	LSB
-55 to +125°C	—	—	±1	LSB
No Missing Codes	Over the operating temperature range			

PERFORMANCE (cont.)	MIN.	TYP.	MAX.	UNITS
Unipolar Zero Error				
+25°C ③	—	—	±0.1	%FSR
-55 to +125°C	—	—	±0.3	%FSR
Bipolar Zero Error				
+25°C ③	—	—	±0.1	%FSR
-55 to +125°C	—	—	±0.3	%FSR
Bipolar Offset Error				
+25°C ③	—	—	±0.1	%FSR
-55 to +125°C	—	—	±0.3	%FSR
Gain Error				
+25°C ③	—	—	±0.2	%
-55 to +125°C	—	—	±0.3	%

DYNAMIC CHARACTERISTICS

Acquisition Time, Gain = 1				
+25°C	—	9	10	μs
-55 to +125°C	—	—	15	μs
Aperture Delay Time	—	—	500	ns
Aperture Uncertainty	—	—	1	ns
S/H Droop Rate	—	—	±1	μV/μs
Feedthrough	—	—	±0.01	%
A/D Conversion Time				
+25°C	—	6	8	μs
-55 to +125°C	—	—	10	μs
Throughput Rate				
+25°C	50	66	—	kHz
-55 to +125°C	33	—	—	kHz

DIGITAL INPUTS

Logic Levels (Pins 8, 13-16, 19-21, 26, 31)				
Logic 1	+2.0	—	+5.5	Volts
Logic 0	0	—	+0.8	Volts
(Pin 5)				
Logic 1	+4.0	—	+5.5	Volts
Logic 0	0	—	+0.8	Volts
Logic Loading (Pins 5, 8, 13-16, 19-21, 26, 31)				
Logic 1	—	—	±10	μA
Logic 0	—	—	±10	μA
Multiplexer Address Set-up Time	20	—	—	ns
ENABLE to Data Valid Delay	—	20	30	ns
STROBE ④	40	—	—	ns

OUTPUTS

Logic Levels (Output Data)				
Logic 1	+2.4	—	—	Volts
Logic 1 (pin 7)	+2.5	—	—	Volts
Logic 0	—	—	+0.4	Volts
(Pins 9, 10, 11, and 12)				
Logic 1	+2.5	—	—	Volts
Logic 0	—	—	+0.4	Volts
Logic Loading				
Logic 1	—	—	-400	μA
Logic 0	—	—	+4	mA
Internal Reference:				
Voltage, +25°C	+9.99	+10.00	+10.01	Volts
Drift	—	—	±20	ppm/°C
External Current	—	—	1	mA
Output Data Coding	Straight binary (unipolar) or offset binary (bipolar)			

FUNCTIONAL SPECIFICATIONS (Continued)

POWER REQUIREMENTS	MIN.	TYP.	MAX.	UNITS
Power Supply Ranges				
+15V Supply	+14.5	+15.0	+15.5	Volts
-15V Supply	-14.5	-15.0	-15.5	Volts
+5V Supply	+4.75	+5.0	+5.25	Volts
Power Supply Currents				
+15V Supply	—	—	+33	mA
-15V Supply	—	—	-30	mA
+5V Supply	—	—	+15	mA
Power Dissipation	—	—	1.25	Watts
PHYSICAL/ENVIRONMENTAL				
Operating Temp. Range, Case				
MC Models	0	—	+70	°C
MM/883 Models	-55	—	+125	°C
Storage Temperature Range				
	-65	—	+150	°C
Weight	1.4 ounces (39.7 grams)			
Package Type	62-pin ceramic DIP			

Footnotes:

- ① Analog inputs will withstand $\pm 35V$ with power on. If the power is off, the maximum safe input (no damage) is $\pm 20V$.
- ② The gain equation error is guaranteed before external trimming and applies at gains less than 50. This error increases at gains over 50.
- ③ Adjustable to zero.
- ④ STROBE pulse width must be less than \overline{EOC} period to achieve maximum throughput rate.

TECHNICAL NOTES

1. Input channels are protected to 20 Volts beyond the power supplies. All digital output pins have one second short-circuit protection.
2. To retain high system throughput rates while digitizing low-level signals, apply external high-gain amplifiers for each channel. DATEL's AM-551 is suggested for such amplifier-per-channel applications.
3. The HDAS devices have self-starting circuits for free-running sequential operation. If, however, in a power-up condition the supply voltage slew rate is less than 3V per microsecond, the free running state might not be initialized. Apply a negative pulse to the STROBE, to eliminate this condition.
4. For unipolar operation, connect BIPOLAR INPUT (pin 38) to S/H OUT (pin 39). For bipolar operation, connect BIPOLAR INPUT (pin 38) to +10V REFERENCE OUT (pin 40).
5. RDELAY may be a standard value 5% carbon composition or film-type resistor.
6. RGAIN must be very accurate with low temperature coefficients. If necessary, fabricate the gain resistor from a precision metal-film type in series with a low value trim resistor or potentiometer. The total resistor temperature coefficient must be no greater than $\pm 10\text{ppm}/^\circ\text{C}$.
7. ANALOG SIGNAL COMMON, POWER COMMON and DIGITAL COMMON are connected internally. For optimal performance, tie all ground pins (17, 41, 42, 45, 46) directly to a large analog ground plane beneath the package.
8. For HDAS-16, tie pin 50 to a "signal source common" if possible. Otherwise tie pin 50 to pin 41 (ANA SIG COM).

INPUT/OUTPUT CONNECTIONS

PIN NO.	HDAS-16	HDAS-8
1	CH3 IN	CH3 HIGH IN
2	CH2 IN	CH2 HIGH IN
3	CH1 IN	CH1 HIGH IN
4	CH0 IN	CH0 HIGH IN
5	MUX ENABLE	*
6	RDELAY	*
7	\overline{EOC}	*
8	STROBE	*
9	A8	MULTIPLEXER
10	A4	ADDRESS
11	A2	OUT
12	A1	*
13	RA8	MULTIPLEXER
14	RA4	ADDRESS
15	RA2	IN
16	RA1	*
17	DIGITAL COMMON	*
18	+5V SUPPLY	*
19	\overline{LOAD}	*
20	\overline{CLEAR}	*
21	\overline{ENABLE} (Bits 9–12)	*
22	BIT 12 (LSB)	*
23	BIT 11	*
24	BIT 10	*
25	BIT 9	*
26	\overline{ENABLE} (Bits 5–8)	*
27	BIT 8	*
28	BIT 7	*
29	BIT 6	*
30	BIT 5	*
31	\overline{ENABLE} (Bits 1–4)	*
32	BIT 4	*
33	BIT 3	*
34	BIT 2	*
35	BIT 1 (MSB)	*
36	GAIN ADJUST	*
37	OFFSET ADJUST	*
38	BIPOLAR INPUT	*
39	SAMPLE/HOLD OUT	*
40	+10V REFERENCE OUT	*
41	ANALOG SIGNAL COMMON	*
42	ANALOG POWER COMMON	*
43	+15V SUPPLY	*
44	-15V SUPPLY	*
45	ANALOG SIGNAL COMMON	*
46	ANALOG SIGNAL COMMON	*
47	RGAIN LOW	*
48	RGAIN HIGH	*
49	AMP. IN HIGH ①	*
50	AMP. IN LOW ①	*
51	CH15 IN	CH7 LOW IN
52	CH14 IN	CH6 LOW IN
53	CH13 IN	CH5 LOW IN
54	CH12 IN	CH4 LOW IN
55	CH11 IN	CH3 LOW IN
56	CH10 IN	CH2 LOW IN
57	CH9 IN	CH1 LOW IN
58	CH8 IN	CH0 LOW IN
59	CH7 IN	CH7 HIGH IN
60	CH6 IN	CH6 HIGH IN
61	CH5 IN	CH5 HIGH IN
62	CH4 IN	CH4 HIGH IN

* Same as HDAS-16

① Caution: Pins 49 and 50 do not have overvoltage protection; therefore, protected multiplexers, such as DATEL's MX-1606 and MX-808 are recommended. See the General Operation description.

Table 1. Description of Pin Functions

FUNCTION	LOGIC STATE	DESCRIPTION
DIGITAL INPUTS		
STROBE	1 to 0	Initiates acquisition and conversion of analog signal
LOAD	0	Random address mode initiated on falling edge of STROBE
	1	Sequential address mode
CLEAR	0	Allows next STROBE pulse to reset MULTIPLEXER ADDRESS to CH0 overriding LOAD COMMAND
MUX ENABLE	0	Disables internal multiplexer
	1	Enables internal multiplexer
MUX ADDRESS IN		Selects channel for random address mode 8, 4, 2, 1 natural binary coding
DIGITAL OUTPUTS		
EOC (STATUS)	0	Conversion complete
	1	Conversion in process
ENABLE (1-4)	0	Enables three-state outputs bits 1-4
	1	Disables three-state outputs bits 1-4
ENABLE (5-8)	0	Enables three-state outputs bits 5-8
	1	Disables three-state outputs bits 5-8
ENABLE (9-12)	0	Enables three-state outputs bits 9-12
	1	Disables three-state outputs bits 9-12
MUX ADDRESS OUT		Output of multiplexer address register 8, 4, 2, 1 natural binary coding
ANALOG INPUTS		DESCRIPTION
CHANNEL INPUTS		Limit voltage to $\pm 20V$ beyond power supplies
BIPOLAR INPUT		For unipolar operation, connect to pin 39 (S/H OUT). For bipolar operation, connect to in 40 (+10V OUT)
AMP. IN LOW AMP. IN HIGH		These pins are direct inputs to the instrumentation amplifier for external channel expansion beyond 16SE or 8D channels.
ANALOG OUTPUTS		
S/H OUT		Sample/hold output
+10V REFERENCE OUT		Buffered +10V reference output
ADJUSTMENT PINS		
ANALOG SIGNAL COMMON		Low level analog signal return
GAIN ADJUSTMENT		External gain adjustment. See calibration instructions.
OFFSET ADJUSTMENT		External offset adjustment. See calibration instructions.
RGAIN		Optional gain selection point. Factory adjusted for $G = 1$ when left open.
RDELAY		Optional acquisition time adjustment when connected to +5V. Factory adjusted for $9\mu s$. Must be connected to +5V either directly or through a resistor.

Table 2. Calibration Table

UNIPOLAR RANGE	ADJUST	INPUT VOLTAGE
0 to +5V	ZERO GAIN	+0.6mV +4.9982V
0 to +10V	ZERO GAIN	+1.2mV +9.9963V
BIPOLAR RANGE		
$\pm 2.5V$	OFFSET GAIN	-2.4994V +2.4982V
$\pm 5V$	OFFSET GAIN	-4.9988V +4.9963V
$\pm 10V$	OFFSET GAIN	-9.9976V +9.9927V

CALIBRATION PROCEDURES

1. Offset and gain adjustments are made by connecting two 20k trim potentiometers as shown in Figure 2.
2. Connect a precision voltage source to pin 4 (CH0 IN). If the HDAS-8 is used, connect pin 58 (CH0 LOW IN) to analog ground. Ground pin 20 (CLEAR) and momentarily short pin 8 (STROBE). Trigger the A/D by connecting pin 7 (EOC) to pin 8 (STROBE). Select proper value for RGAIN and RDELAY by referring to Table 3.
3. Adjust the precision voltage source to the value shown in Table 2 for the unipolar zero adjustment (ZERO + 1/2LSB) or the bipolar offset adjustment (-FS + 1/2LSB). Adjust the offset trim potentiometer so that the output code flickers equally between 0000 0000 0000 and 0000 0000 0001.
4. Change the output of the precision voltage source to the value shown in Table 2 for the unipolar or bipolar gain adjustment (+FS - 1 1/2LSB). Adjust the gain trim potentiometer so that the output flickers equally between 1111 1111 1110 and 1111 1111 1111.

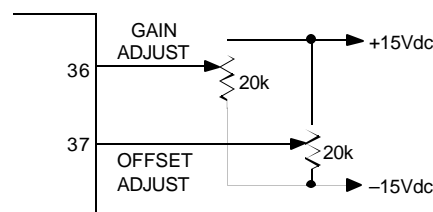

Figure 2. External Adjustment

GENERAL OPERATION

The HDAS devices accept either 16 single-ended or 8 differential input signals. For single-ended circuits, the AMP IN LOW (pin 50) input to the instrumentation amplifier must terminate at ANALOG SIGNAL COMMON (pin 41). For differential circuits, both the HIGH and LOW signal inputs must terminate externally for each channel. Tie unused channels to the ANALOG SIGNAL COMMON (pin 41). To obtain additional channels, connect external multiplexers to the AMP IN HIGH (pin 49) and AMP IN LOW (pin 50). Using this scheme, the HDAS-16 can provide 32 single-ended expansion channels while the HDAS-8 can provide up to 16 differential expansion channels. DATEL's MX Series multiplexers are recommended.

The acquisition time is the amount of time the multiplexer, instrumentation amplifier, and sample/hold require to settle within a specified range of accuracy after STROBE (pin 8) goes low. The acquisition time period can be observed by measuring how long EOC is low after the falling edge of STROBE (see Figure 4). For higher gains, increase the acquisition time. Do this by connecting a resistor from RDELAY (pin 6) to +5V (pin 18). An external resistor, RGAIN, can be added to increase the gain value. The gain is equal to 1 without an RGAIN resistor. Table 3 refers to the appropriate RDELAY and RGAIN resistors required for various gains.

The HDAS devices enter the hold mode and are ready for conversion as soon as the one-shot (controlling acquisition time) times out. An internal clock is gated ON, and a start-convert pulse is sent to the 12-bit A/D converter, driving the EOC output high.

The HDAS devices can be configured for either bipolar or unipolar operation (see Table 2). The conversion is complete within a maximum of 10 microseconds. The EOC now returns low, the data is valid and sent to the three-state output buffers. The sample/hold amplifier is now ready to acquire new data. The next falling edge of the STROBE pulse repeats the process for the next conversion.

MULTIPLEXER ADDRESSING

The HDAS devices can be configured in either random or sequential addressing modes. Refer to Table 5 and the subsequent descriptions. The number of channels sequentially addressed can be truncated using the MUX ADDRESS OUT (pins 9, 10, 11 and 12) and appropriate decoding circuitry for the highest channel desired. The decoding circuit can drive the CLEAR (pin 20) function low to reset the addressing to channel 0.

Table 3. Input Range Parameters (Typical)

INPUT RANGE ①②	GAIN	RGAIN (Ω)	RDELAY (Ω) ③	THROUGHPUT ④	SYSTEM ACCURACY (% OF FSR)
±10V	1	OPEN	0 (SHORT)	66.6kHz	±0.009
±5V	2	20.0k	0 (SHORT)	66.6kHz	±0.009
±2.5V	4	6.667k	0 (SHORT)	66.6kHz	±0.009
±1V	10	2.222k	0 (SHORT)	66.6kHz	±0.009
±200mV	50	408.2	7k	40.0kHz	±0.010
±100mV	100	202.0	21k	25.6kHz	±0.011
±50mV	200	100.5	51k	14.5kHz	±0.016

Notes

$$RGAIN (\Omega) = \frac{20,000}{(GAIN - 1)}$$

$$RDELAY (\Omega) = [Total\ Acquisition\ Delay (\mu s) \times 1000] - 9000$$

- ① The analog input range to the A/D converter is 0 to +10V for unipolar signals and ±10V for bipolar signals.
- ② Full scale can be accommodated for analog signal ranges of ±50mV to ±10V.
- ③ For gains between 1 and 10, RDELAY (pin 6) must be shorted to +5V (pin 18).
- ④ Throughput period equals acquisition and settling delay, plus A/D conversion period (10 microseconds maximum).

Table 4. Output Coding

INPUT	UNIPOLAR		STRAIGHT BINARY		
	0 to +10V	0 to +5V	MSB	LSB	
+FS – 1LSB	+9.9976	+4.9988	1111	1111	1111
+1/2FS	+5.0000	+2.5000	1000	0000	0000
+1LSB	+0.0024	+0.0012	0000	0000	0001
ZERO	0.0000	0.0000	0000	0000	0000

INPUT	BIPOLAR		OFFSET BINARY*		
	±10V	±5V	MSB	LSB	
+FS – 1LSB	+9.9951	+4.9976	1111	1111	1111
+1/2FS	+5.0000	+2.5000	1100	0000	0000
+1LSB	+0.0049	+0.0024	1000	0000	0001
ZERO	0.0000	0.0000	1000	0000	0000
–FS + 1LSB	–9.9951	–4.9976	0000	0000	0001
–FS	–10.000	–5.0000	0000	0000	0000

* For 2's complement coding, add an inverter to the MSB line.

Table 5. Mux Channel Addressing

MUX ENABLE	PIN MUX ADDRESS				ON CHANNEL		
	5	13	14	15			16
	RA8	RA4	RA2	RA1			
0	X	X	X	X	NONE		
1	0	0	0	0	0		
1	0	0	0	1	1		
1	0	0	1	0	2		
1	0	0	1	1	3		
1	0	1	0	0	4		
1	0	1	0	1	5		
1	0	1	1	0	6		
1	0	1	1	1	7		
1	1	0	0	0	8		
1	1	0	0	1	9		
1	1	0	1	0	10		
1	1	0	1	1	11		
1	1	1	0	0	12		
1	1	1	0	1	13		
1	1	1	1	0	14		
1	1	1	1	1	15		

HDAS-8
(3-BIT ADDRESS)

HDAS-16
(4-BIT ADDRESS)

RANDOM ADDRESSING

Set pin 19 (\overline{LOAD}) to logic 0. The next falling edge of \overline{STROBE} will load the MUX CHANNEL ADDRESS present on pin 13 to pin 16. Digital address inputs must be stable 20ns before and after falling edge of the \overline{STROBE} pulse.

FREE RUNNING SEQUENTIAL ADDRESSING

Set pin 19 (\overline{LOAD}) and pin 20 (\overline{CLEAR}) to logic 1 or leave open. Connect pin 7 (\overline{EOC}) to pin 8 (\overline{STROBE}). The falling edge of \overline{EOC} will increment channel address. This means that when the \overline{EOC} is low, the digital output data is valid for the previous channel ($CH_n - 1$) rather than the channel indicated on MUX ADDRESS OUTPUT. The HDAS will continually scan all channels.

Example:

CH_4 has been addressed and a conversion takes place. The \overline{EOC} goes low. That channel's (CH_4 's) data becomes valid, but MUX ADDRESS OUTPUT is now CH_5 .

TRIGGERED SEQUENTIAL ADDRESSING

Set pin 19 (\overline{LOAD}) and pin 20 (\overline{CLEAR}) to logic 1 or leave open. Apply a falling edge trigger pulse to pin 8 (\overline{STROBE}). This negative transition causes the contents of the address counter to be incremented by one, followed by an A/D conversion in 9 microseconds.

INPUT VOLTAGE PROTECTION

As shown in Figure 3, the multiplexer has reversed biased diodes which protect the input channels from being damaged by overvoltage signals. The HDAS input channels are protected up to 20V beyond the supplies and can be increased by adding series resistors (R_i) to each channel. The input resistor must limit the current flowing through the protection diodes to 10mA.

The value of R_i for a specific voltage protection range (V_p) can be calculated by the following formula:

$$V_p = (R_{signal} + R_i + R_{ON})(10mA)$$

where $R_{ON} = 2k$

NOTE: Increased input series resistance will increase multiplexer settling time significantly.

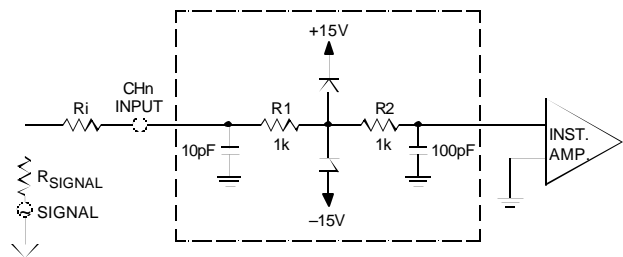

Figure 3. Multiplexer Equivalent Circuit

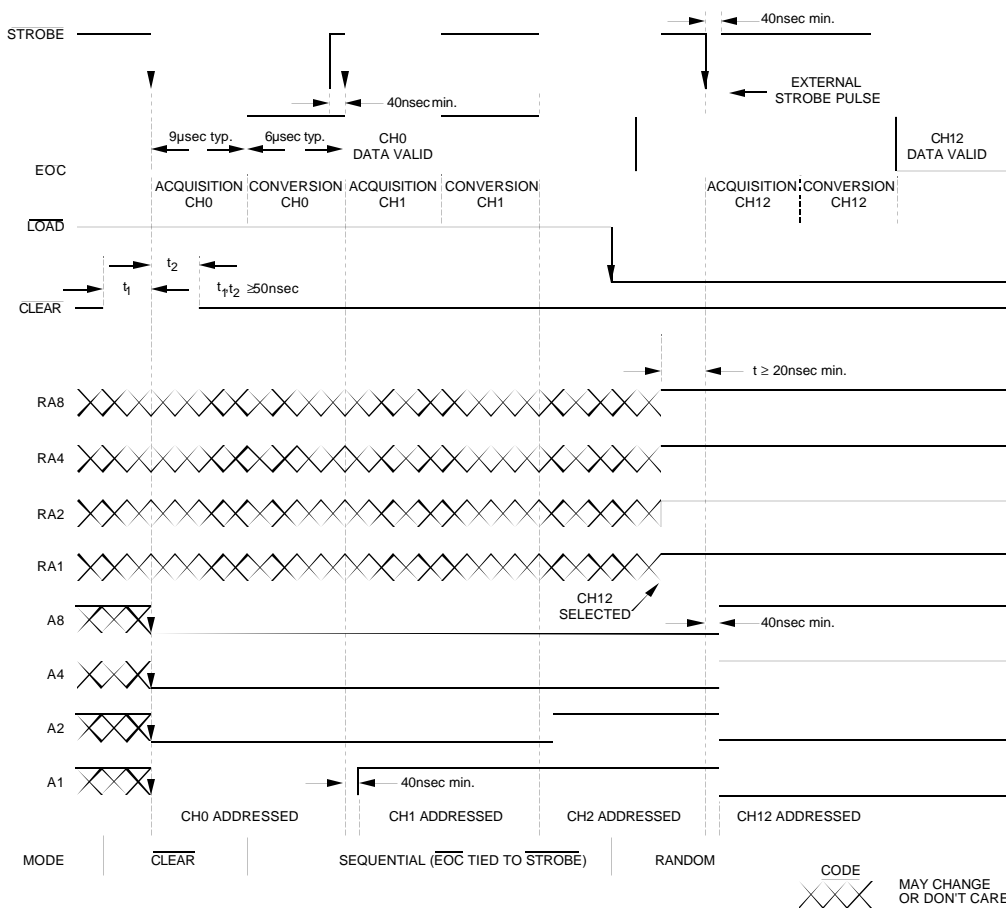
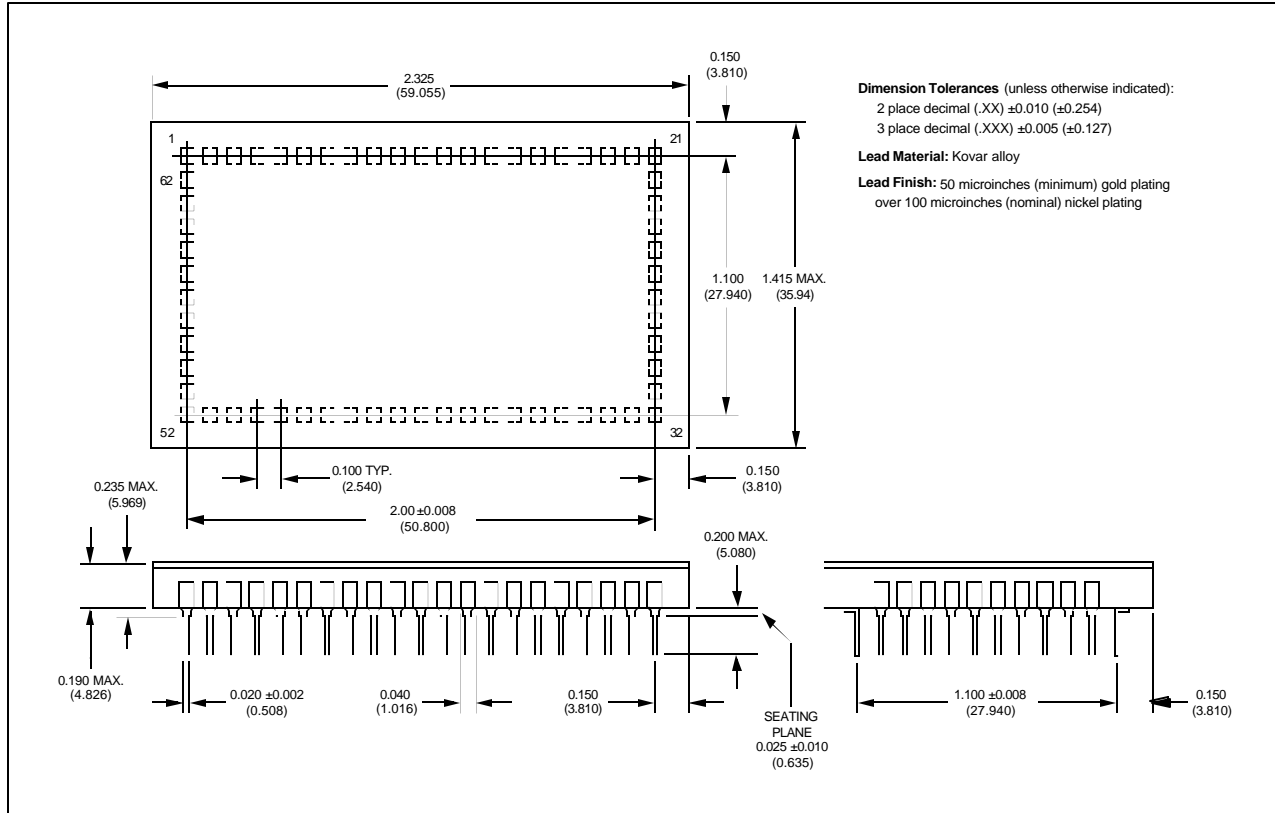

Figure 4. HDAS Timing Diagram

MECHANICAL DIMENSIONS INCHES (mm)



ORDERING INFORMATION

MODEL NO.	OPERATING TEMP. RANGE
HDAS-16MC	0 to +70°C
HDAS-16MM	-55 to +125°C
HDAS-16/883	-55 to +125°C
HDAS-8MC	0 to +70°C
HDAS-8MM	-55 to +125°C
HDAS-8/883	-55 to +125°C

Receptacles for PC board mounting can be ordered through AMP Inc., Part #3-331272-4 (Component Lead Spring Socket), 62 required.

Contact DATEL, Inc. for MIL-STD-883 product specifications.