

CT2542 / CT2543

Dual Redundant Remote Terminal for MIL-STD-1553B

www.aeroflex.com/Avionics

September 16, 2005



FEATURES

- ❑ CT2542 Replaces DDC BUS-65142 and BUS-65144
- ❑ CT2543 Replaces DDC BUS-65143 and BUS-65145
- ❑ Functions as a Complete Remote Terminal Unit
- ❑ Supports 13 Mode Codes, Illegalization of Codes Allowed
- ❑ Transfers Data with DMA Type Handshaking
- ❑ Latched Outputs for Command Word and Word Count
- ❑ 14 Bit Built-In-Test Word Register
- ❑ 4 Error Flag Outputs
- ❑ Advanced Low Power VLSI Technology
- ❑ Designed for commercial, industrial and aerospace applications
- ❑ MIL-PRF-38534 compliant devices available
- ❑ Aeroflex-Plainview is a Class H & K MIL-PRF-38534 manufacturer
- ❑ Packaging – Hermetic Metal
 - 68 Pin, 2.1" x 1.87" x .25" Plug-In Type Package
 - 82 Leads, 2.20" x 1.61" x .18" Flat Type Package
- ❑ DESC SMD# 5962-89798

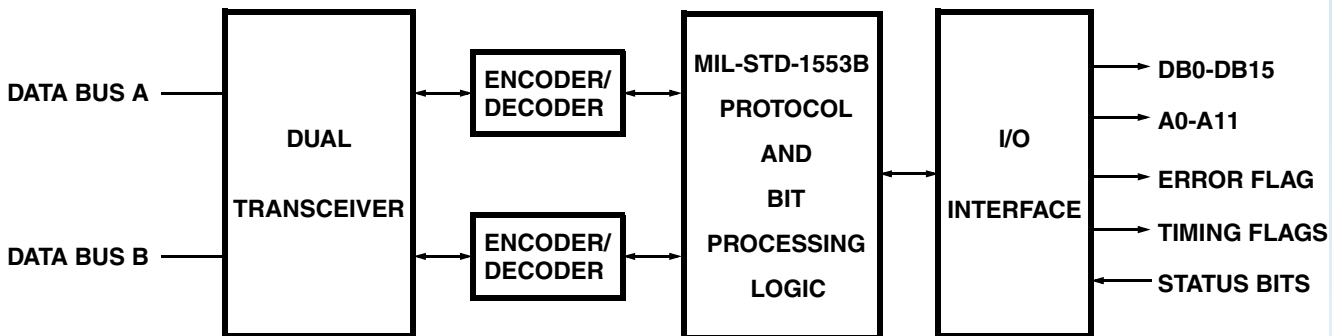

FIGURE 1 – FUNCTIONAL BLOCK DIAGRAM

DESCRIPTION

The Aeroflex-Plainview CT2542 contains 2 Transceivers, 2 Encoder/Decoders, Bit Processors and complete Remote Terminal (RT) logic. The device is constructed using Aeroflex advanced VLSI custom chip and hybrid technology. It functions as a complete dual redundant MIL-STD-1553B RT Unit supporting all 13 mode codes for dual redundant operation. The CT2542 is a pin-for-pin functional equivalent of the DDC BUS-65142/144 and performs parallel data transfers with a DMA type handshake. Multiple error flag outputs and host access to many of the RT Status Word bits are just some of the features that make this part ideal for many RT applications. The unit has an operating range of -55°C to +125°C. See "Ordering Information" (last sheet) for CT2543.

ABSOLUTE MAXIMUM RATINGS

Parameter	Limits	Units
Power Supply Voltage (V _{EE})	+0.3 to -18.0	Volts
Power Supply Voltage (V _{CCL})	-0.3 to +7.0	Volts
Receiver Differential Input	±20 (40V _{p-p})	Volts
Receiver Input Voltage	±15	Volts
Driver Output Current	+200	mA
Transmission Duty Cycle at T _C = 125°C	100	%
Operating Case Temperature Range (T _C)	-55 to +125	°C

POWER AND THERMAL DATA (SINGLE TRANSCEIVER AND LOGIC SECTION)

Parameter/Conditions	Symbol	Min	Typ	Max	Units
Power Supply Voltage	V _{EE} V _{CCL}	-14.25 4.5	-15 5	-15.75 5.5	V V
Thermal Resistance, most critical device	θ _{JC}	-	60	-	°C/W
Power dissipation of most critical (hottest) device during continuous transmission (100% duty cycle) ^{1/}	P _C	-	350	-	mW
Total supply current standby mode, or transmitting at less than 1% duty cycle (e.g. 20us of transmission every 2ms or longer interval)	I _{EE} I _{CCL} ^{2/}	- -	50 -	70 50	mA mA
Total supply current transmitting at 1Mhz into a 35-ohm load at Point A in Figure 2 ^{3/}	I _{EE} @ 50% I _{EE} @ 100%	- -	- -	175 270	mA mA

Notes

^{1/} Decreases linearly to zero at zero duty cycle.

^{2/} I_{ccl} limit does not change with mode of operation or duty cycle.

^{3/} Decreases linearly to applicable "standby" values at zero duty cycle.

ELECTRICAL CHARACTERISTICS (RECEIVER SECTION)

Parameter/Conditions	Symbol	Min	Max	Units
Differential input impedance DC to 1MHz, Point B, Figure 2	Z _{IN}	2K	-	Ω
Differential voltage range	V _{DIR}	±20V	-	V _{PK}
Input common mode voltage range	V _{ICR}	±10V	-	V _{PK}
Common mode rejection ratio (from Point A, Figure 1)	CMMR	40	-	dB
Threshold characteristics (Sine wave at 1MHz) Note: Threshold voltages refer to Point A, Figure 2.	V _{TH}	0.86	1.2	V _{PK-PK}

ELECTRICAL CHARACTERISTICS (TRANSMITTER SECTION)

Parameter/Conditions	Symbol	Min	Typ	Max	Units
Differential output level at Point B, Figure 2 (145-ohm load)	V_O	24	-	35	VPK-PK
Rise and Fall times (10% to 90% of p-p output)	t_R & t_F	100	-	300	nS
Output offset at Point A in Figure 2 (35-ohm load) 2.5us after mid-bit crossing of parity bit of last word of a 660us message	V_{OS}	-	± 20	± 90	mV _{PK}
Differential output noise	V_{NOI}	-	-	10	mV _{PK-PK}

LOGIC CHARACTERISTICS

Symbol	Parameter	Min	Max	Units	Conditions
V_{IH}	Input "1"	2.4	-	VDC	
V_{IL}	Input "0"	-	0.7	VDC	
I_{IL}	Input 1	-80	-400	μA	Note 1A
I_{IH}	Input 1	-40	-200	μA	Note 1B
I_{IL}	Input 1	-20	+20	μA	Note 2A
I_{IH}	Input 1	-20	+20	μA	Note 1B
I_{IL}	Input 1	-20	-200	μA	Note 5
I_{IH}	Input 1	-40	-400	μA	
V_{OH}	Output "1"	2.7	-	VDC	Note 3A/4A
V_{OL}	Output "0"	-	0.4	VDC	Note 3B/4B

Note 1: For INPUT pins 12,13,14,15, 53, 54, 55 (DDIP).
 $V_{CC} = 5.5V$
 A. @ $V_{IL} = 0.4V$
 B. @ $V_{IH} = 2.4V$

Note 2: All remaining INPUTS other than in Note 1.
 $V_{CC} = 5.5V$
 A. @ $V_{IL} = 0.4V$
 B. @ $V_{IH} = 2.4V$

Note 3: For OUTPUT pins 4 through 11 and 43 through 50 (DDIP).
 A. @ $V_{CC} = 4.5V$ and $I_{OH} = 2mA$
 B. @ $V_{CC} = 2.4V$ and $I_{OL} = 4mA$

Note 4: All remaining OUTPUTS other than in Note 3.
 A. @ $V_{CC} = 4.5V$ and $I_{OH} = 1mA$
 B. @ $V_{CC} = 5.5V$ and $I_{OL} = 2mA$

Note 5: For INPUT pins 4-11, 43-50 (DDIP).
 $V_{CC} = 5.5V$
 A. @ $V_{IL} = 0.4V$
 B. @ $V_{IH} = 2.4V$

TERMINAL CONNECTIONS AND PIN FUNCTIONS

Plug-In Pkg	Flat Pkg	Function	Description
1	2	A9	Latched output of the most significant bit (MSB) in the subaddress field of the command word.
2	4	A7	Latched output of the third most significant bit in the subaddress field of the command word.
3	6	A5	Latched output of the least significant bit (LSB) in the subaddress field of the command word.
4	8	DB1	Bidirectional parallel data bus bit 1.
5	10	DB3	Bidirectional parallel data bus bit 3.
6	12	DB5	Bidirectional parallel data bus bit 5.
7	14	DB7	Bidirectional parallel data bus bit 7.
8	16	DB9	Bidirectional parallel data bus bit 9.
9	18	DB11	Bidirectional parallel data bus bit 11.
10	20	DB13	Bidirectional parallel data bus bit 13.
11	22	DB15	Bidirectional parallel data bus bit 15 (MSB).
12	24	BRO ENA	Broadcast enable - When HIGH, this input allows recognition of an RT address of all ones in the command word as a broadcast message. When LOW, it prevents response to RT address 31 unless it was the assigned terminal address.
13	26	ADDRE	Input of the MSB of the assigned terminal address.
14	28	ADDRC	Input of the 3rd MSB of the assigned terminal address.
15	30	ADDRA	Input of the 3rd MSB of the assigned terminal address.
16	32	$\overline{\text{RTADDERR}}$	Output signal used to inform subsystem of an address parity error. If LOW, indicates parity error and the RT will not respond to any command address to a single terminal. It will still receive broadcast commands if BRO ENA is HIGH.
17	34	$\overline{\text{TXDATAOUT B}}$	LOW output to the primary side of the coupling transformer that connects to the B channel of the 1553 bus.
18	36	N/C	No connection.
19	38	GND B	Power supply return connection for the B channel transceiver.
20	40	RXDATAIN B	Input from the HIGH side of the primary side of the coupling transformer that connects to the B channel of the 1553 bus.
21	81	A3	Multiplexed address line output. When INCMD is LOW, or A5 through A9 are all zeroes or all ones (mode command), it represents the latched output of the 2nd MSB in the word count field of the command word. When INCMD is HIGH and A5 through A9 are not all zeroes or all ones, it represents the 2nd MSB of the current word counter. (See note 1).
22	79	A1	Multiplexed address line output. When INCMD is LOW, or A5 through A9 are all zeroes or all ones (mode command), it represents the latched output of the 2nd LSB in the word count field of the command word. When INCMD is HIGH and A5 through A9 are not all zeroes or all ones, it represents the 2nd LSB of the current word counter. (See note 1).
23	77	$\overline{\text{DTGRT}}$	Data transfer grant - Active LOW input signal from the subsystem that informs the RT, when $\overline{\text{DTREQ}}$ is asserted, to start the transfer. Once the transfer is started, $\overline{\text{DTGRT}}$ can be removed.
24	75	INCMD	In command - HIGH level output signal used to inform the subsystem that the RT is presently servicing a command. When low, A0-A4 (see note 1) represent the word count of the present command. When high, A0-A4 represent the current word counter of non-mode commands.

TERMINAL CONNECTIONS AND PIN FUNCTIONS (con't)

Plug-In Pkg	Flat Pkg	Function	Description
25	73	$\overline{\text{HS FAIL}}$	Handshake fail - Output signal that goes LOW and stays LOW whenever the subsystem fails to supply DTGRT in time to do a successful transfer. Cleared by the next NBGT.
26	71	$\overline{\text{DTSTR}}$	DATA strobe - A LOW level output pulse (125 ns) present in the middle of every data word transfer over the parallel data bus. Used to latch or strobe the data into memory, FIFOs, registers, etc. Recommend using the rising edge to clock data in. (See note 2).
27	69	$\overline{\text{DAT/CMD}}$	Address line output that is LOW whenever the command word is being transferred to the subsystem over the parallel data bus, and is HIGH whenever data words are being transferred.
28	67	$\overline{\text{RT FAIL}}$	Remote terminal failure - Latched active LOW output signal to the subsystem to flag detection of a remote terminal continuous self-test failure. Also set if the watchdog timeout circuit is activated. Cleared by the start of the next message transmission (status word) and set if problem is again detected.
29	65	$\overline{\text{DTREQ}}$	Data transfer request - Active LOW output signal to the subsystem indicating that the RT has data for or needs data from the subsystem and requests a data transfer over the parallel data bus. Will stay LOW until transfer is completed or transfer until transfer is completed or transfer timeout has occurred.
30	63	$\overline{\text{ADBC}}$	Accept dynamic bus control - Active LOW input signal from subsystem used to set the dynamic bus control acceptance bit in the status register if the command word was a valid, legal mode command for dynamic bus control.
31	61	TEST 2	Factory test point - DO NOT USE. (See note 3).
32	59	A10	Latched output of the T/R bit in the command word.
33	57	$\overline{\text{ILL CMD}}$	Illegal command - Active LOW input signal from the subsystem, strobed in on the rising edge of INCMD. Used to define the command word as illegal and to set the message error bit in the status register.
34	55	$\overline{\text{SS REQ}}$	Subsystem service request - Input from the subsystem used to control the service request bit in the status register. If LOW when the status word is updated, the service request bit will be set; if HIGH, it will be cleared.
35	53	$\overline{\text{BITEN}}$	Built-in-test word enable - LOW level output pulse (500 ns), present when the built-in-test word is enabled on the parallel data bus. (See note 4).
36	51	$\overline{\text{RXDATAIN A}}$	Input from the LOW side of the primary side of the coupling transformer that connects to the A channel of the 1553 bus.
37	49	VLA	+5 Volt input power supply connection for the A channel transceiver.
38	47	V _{EEA}	-15 / -12 Volt input power supply connection for the A channel transceiver. (See note 7).
39	45	$\overline{\text{TXDATAOUT A}}$	HIGH output to the primary side of the coupling transformer that connects to the A channel of the 1553 bus.
40	43	$\overline{\text{NBGT}}$	New bus grant - LOW level output pulse (125 ns) used to indicate the start of a new protocol sequence in response to the command word just received. (See note 2).
41	3	A8	Latched output of the 2nd MSB in the subaddress field of the command word.
42	5	A6	Latched output of the 2nd LSB in the subaddress field of the command word.
43	7	DB0	Bidirectional parallel data bus bit 0 (LSB).
44	9	DB2	Bidirectional parallel data bus bit 2.
45	11	DB4	Bidirectional parallel data bus bit 4.
46	13	DB6	Bidirectional parallel data bus bit 6.
47	15	DB8	Bidirectional parallel data bus bit 8.

TERMINAL CONNECTIONS AND PIN FUNCTIONS (con't)

Plug-In Pkg	Flat Pkg	Function	Description
48	17	DB10	Bidirectional parallel data bus bit 10.
49	19	DB12	Bidirectional parallel data bus bit 12.
50	21	DB14	Bidirectional parallel data bus bit 14.
51	23	V _L	+5 Volt input power supply connection for RTU digital logic section.
52	25	GND	Power supply return for RTU digital logic section.
53	27	ADDRD	Input of the 2nd MSB of the assigned terminal address.
54	29	ADDRB	Input of the 2nd LSB of the assigned terminal address.
55	31	ADDRP	Input of address parity bit. The combination of assigned terminal address and ADDR _P must be odd parity for the RT to work.
56	33	TXDATAOUT B	HIGH, output to the primary side of the coupling transformer that connects to the B channel of the 1553 bus.
57	35	V _{EEB}	-15 / -12 Volt input power supply connection for the B channel transceiver. (See note 7).
58	37	V _{LB}	+5 Volt input power supply connection for the B channel transceiver.
59	39	R _X DATAIN B	Input from the LOW side of primary side of the coupling transformer that connects to the B channel of the 1553 bus.
60	80	A2	Multiplexed address line output. When INCMD is LOW, or A5 through A9 are all zeroes or all ones (mode command), it represents the latched output of the 3rd MSB in the word count field of the command word. When INCMD is HIGH and A5 through A9 are not all zeroes or all ones, it represents the 3rd MSB of the current word counter. (See note 1).
61	78	A0	Multiplexed address line output. When INCMD is LOW, or A5 through A9 are all zeroes or all ones (mode command), it represents the latched output of the LSB in the word count field of the command. When INCMD is HIGH and A5 through A9 are not all zeroes or all ones, it represents the LSB of the current word counter. (See note 1).
62	76	D _T TACK	Data transfer acknowledge - Active LOW output signal during data transfers to or from the subsystem indicating the RTU has received the DTGRT in response to DTREQ and is presently doing the transfer. Can be connected directly pins 67 on Plug-In Pkg or pin 66 on Flat Pkg (BUF ENA) for control of 3-state data buffers; and to 3-state address buffer control lines, if they are used.
63	74	A4	Multiplexed address line output. When INCMD is LOW or A5 through A9 are all zeroes or all ones (mode command), it represents the latched output of the MSB in the word count field of the command word. When INCMD is HIGH and A5 through A9 are not all zeroes or all ones, it represents the MSB of the current word counter. (See note 1).
64	72	R/W	Read/Write - Output signal that controls the direction of the internal data bus buffers. Normally, the signal is LOW and the buffers drive the data bus. When data is needed from the subsystem, it goes HIGH to turn the buffers around and the RT now appears as an input. The signal is HIGH only when DTREQ is active (LOW).
65	70	G _B R	Good block received - LOW level output pulse (500 ns) used to flag the subsystem that a valid, legal, non-mode receive command with the correct number of data words has been received without a message error and successfully transferred to the subsystem. (See note 4).
66	68	16 MHz	16 MHz clock input - Input for the master clock used to run RTU circuits.
67	66	B _U F ENA	Buffer enable - Input used to enable or 3-state the internal data bus buffers when they are driving the bus. When LOW, the data bus buffers are enabled. Could be connected to DTACK, (pin 62, Plug-In Pkg), (pin 76, Flat Pkg) if RT is sharing the same data bus as the subsystem. (See note 5).
68	64	R _E SET	Input resets entire RT when LOW.

TERMINAL CONNECTIONS AND PIN FUNCTIONS (con't)

Plug-In Pkg	Flat Pkg	Function	Description
69	62	$\overline{\text{RT FLAG}}$	Remote terminal flag - Input signal used to control the terminal flag bit in the status register. If LOW when the status word is updated, the terminal flag bit would be set; if HIGH, it would be cleared. Normally connected to $\overline{\text{RTFAIL}}$; (pin 28, Plug-In Pkg); (pin 67, Flat Pkg).
70	60	TEST 1	Factory test point - DO NOT USE. (See note 6).
71	58	$\overline{\text{BUSY}}$	Subsystem busy - Input from the subsystem used to control the busy bit in the status register. If LOW when the status word is updated, the busy bit will be set; if HIGH, it will be cleared. If the busy bit is set in the status register, no data will be requested from the subsystem in response to a transmit command. On receive commands, data will still be transferred to subsystem.
72	56	$\overline{\text{SS FLAG}}$	Subsystem flag - Input from the subsystem used to control the subsystem flag bit in the status register. If LOW when the status word is updated, the subsystem flag will be set; if HIGH, it will be cleared.
73	54	$\overline{\text{MESS ERR}}$	Message error - Output signal that goes LOW and stays low whenever there is a format or word error with the received message over the 1553 data bus. Cleared by the next $\overline{\text{NBGT}}$.
74	52	RXDATAIN A	Input from the HIGH side of the primary side of the coupling transformer that contacts to the A channel of the 1553 bus.
75	50	GND A	Power supply return connection for the A channel transceiver.
76	48	N/C	No connection. (See note 7).
77	46	$\overline{\text{TXDATAOUT A}}$	LOW output to the primary side of the coupling transformer that connects to the A channel of the 1553 bus.
78	44	$\overline{\text{STATEN}}$	Status word enable - LOW level active output signal present when the status word is enabled on the parallel data bus.

NOTES:

- When INCMD is LOW during the $\overline{\text{DTSTR}}$ immediately following $\overline{\text{NBGT}}$, A0 through A4 are valid and equal to WC0 through WC4 of the received command word. The remaining time while INCMD is LOW and A5 through A9 are not all zeros or ones (i.e. MODE), A0 through A4 are equal to the last current word count plus one. When INCMD is HIGH and A5 through A9 are not MODE, A0 through A4 represent the current word counter. If A5 through A9 are equal to MODE, A0 through A4 are equal to WC0 through WC4 of the received command word, independent of the state of INCMD.
- Pulse width is typically 125 ns.
- Pin 31 for Plug-In Pkg, and pin 61 for Flat Pkg - (TEST 2) factory test point output: This pin provides the output of the device BIT comparison output. It indicates the loop test results for every word transmitted by the device. A test can be performed by actuating the RTU to transmit while the test fixture opens the receiver lines to force an error condition. A logic 1 (high) indicates the loop test passed. Normally this pin is left open. For Plug-In Pkg and Flat Pkg TEST 2 is not implemented and should be left open.
- Pulse width is typically 375 ns.
- Pin 67 for Plug-In Pkg, and pin 66 for Flat Pkg - $\overline{\text{BUF ENA}}$: This pin is typically tied to $\overline{\text{DTACK}}$, causing the device to drive the shared data bus only while $\overline{\text{DTACK}}$ is active. If desired $\overline{\text{BUF ENA}}$ can be grounded. The data will remain latched on the data bus pins for 19 μs from $\overline{\text{DTSRB}}$ and 4 μs for the last word of a message as the devices status word or BIT word is transferred to the BC ($\overline{\text{STATEN}}$ or $\overline{\text{BITEN}}$ low). Once the STATUS or BIT word transfer is complete, the data bus will automatically again contain the last data word. The device will automatically switch the direction of the internal buffers during a transmit operation.
- Pin 70 for Plug-In Pkg, and pin 60 for Flat Pkg - (TEST 1) factory test point: This test allows the user to force the active channel to transmit indefinitely, in order to test the built-in watchdog timer feature of the device. When this pin is grounded and the active channel is stimulated with a valid transmit command, the device will respond with a status word and contiguous data (last data word loaded or STATUS WORD if none is loaded) until the built-in timeout occurs. Normally this pin is left open or an optional pull-up can be used. For Plug-In Pkg and Flat Pkg (TEST 1) is not implemented and should be left open.
- For Flat Pkg, pins 1, 41, 42, and 82 are no connections.

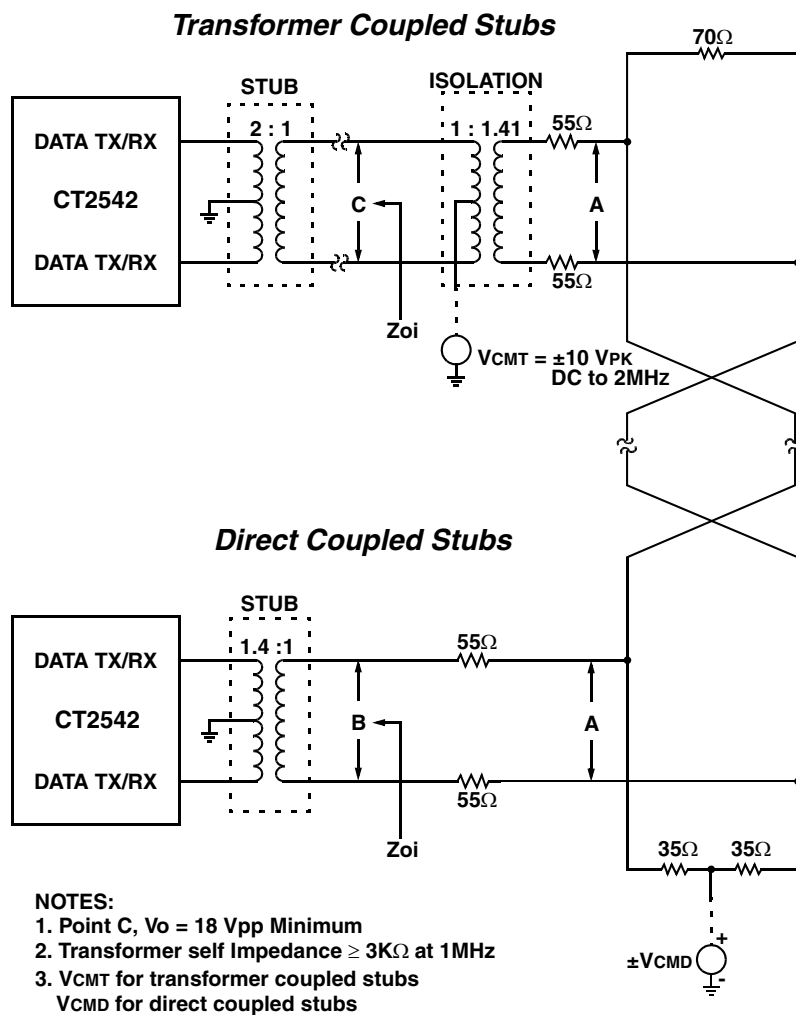

FIGURE 2 – TYPICAL BUS COUPLED CONFIGURATIONS

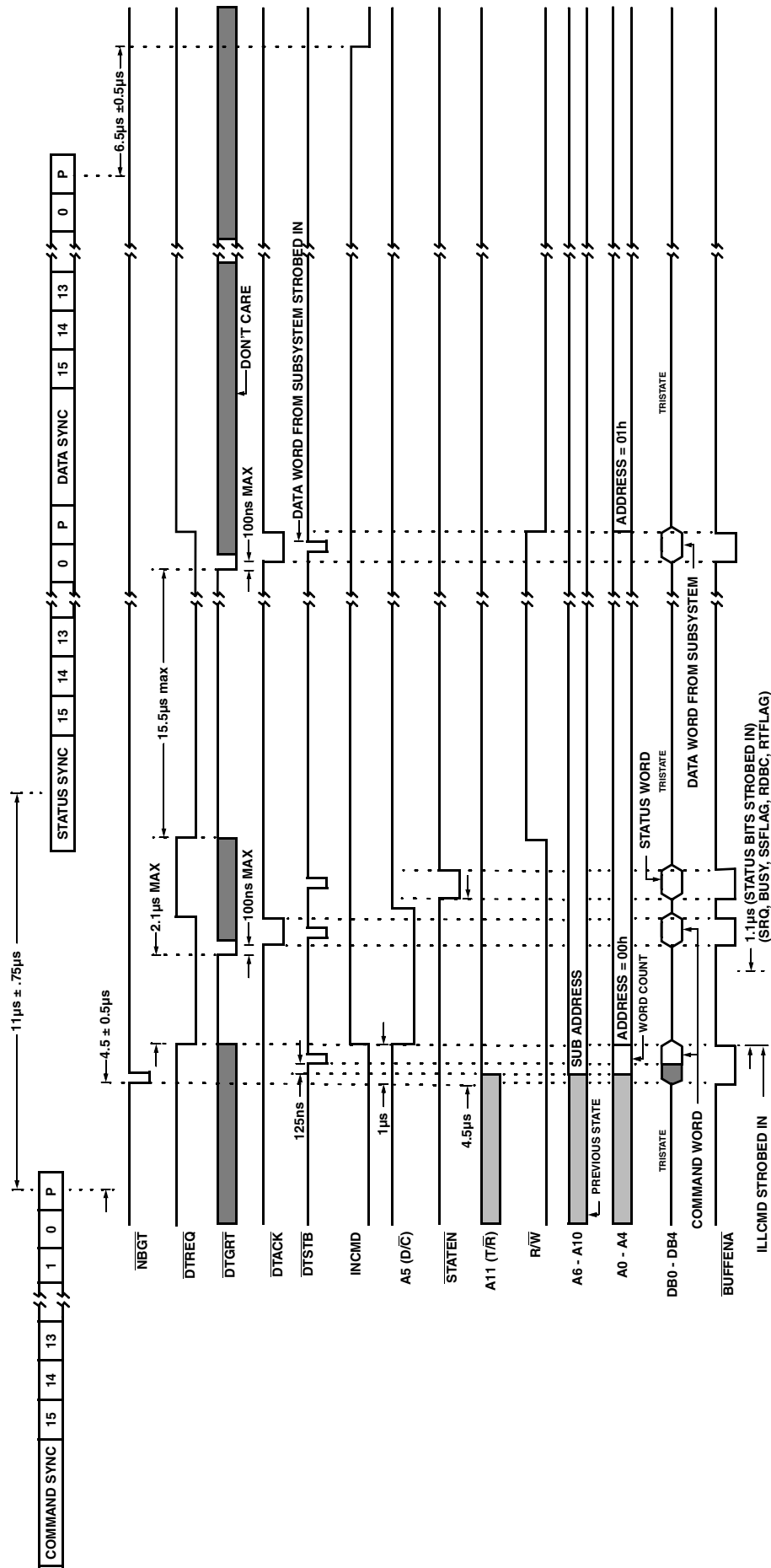

FIGURE 3 – TIMING DIAGRAM, TRANSMIT ONE WORD

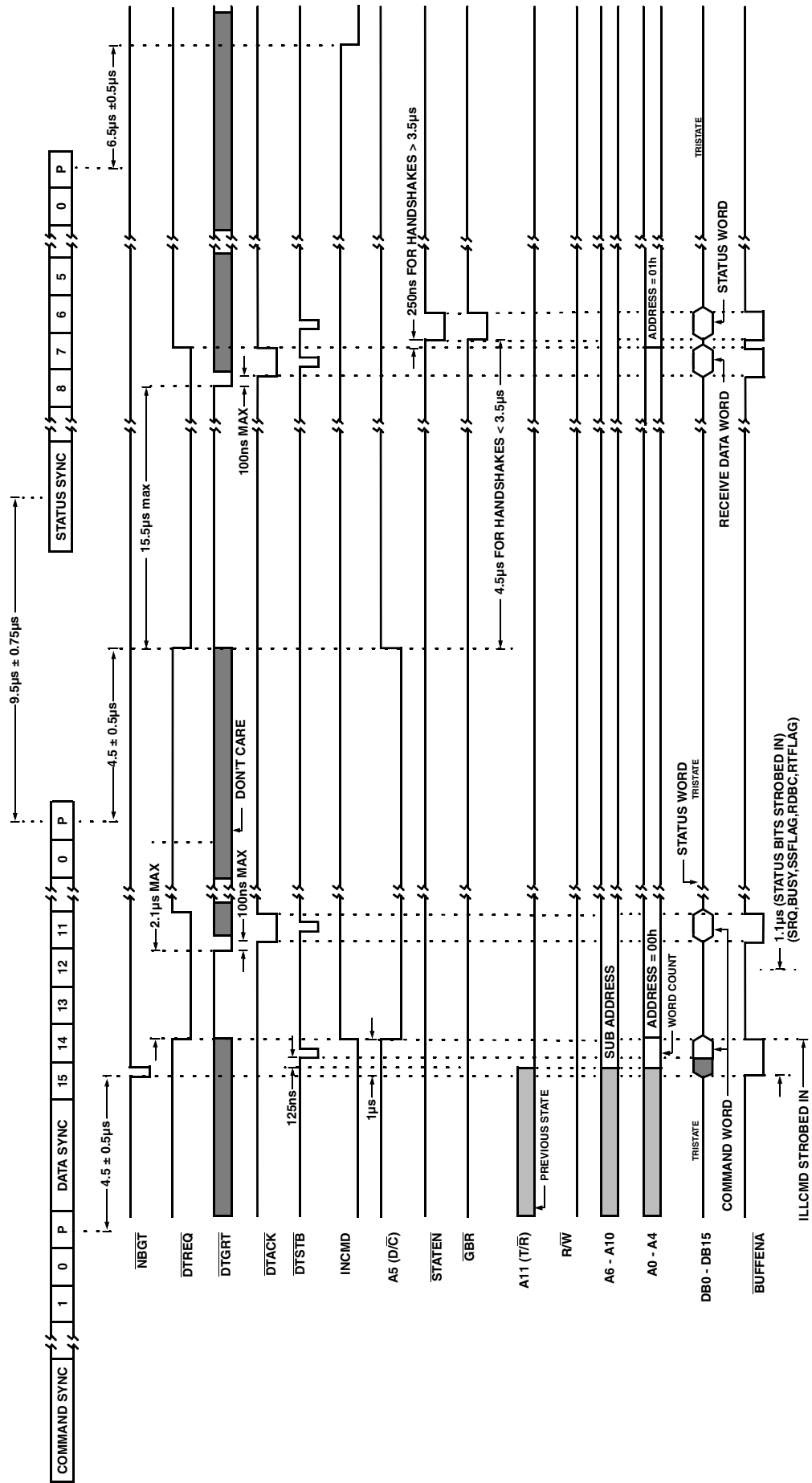

FIGURE 4 – TIMING DIAGRAM, RECEIVE ONE WORD

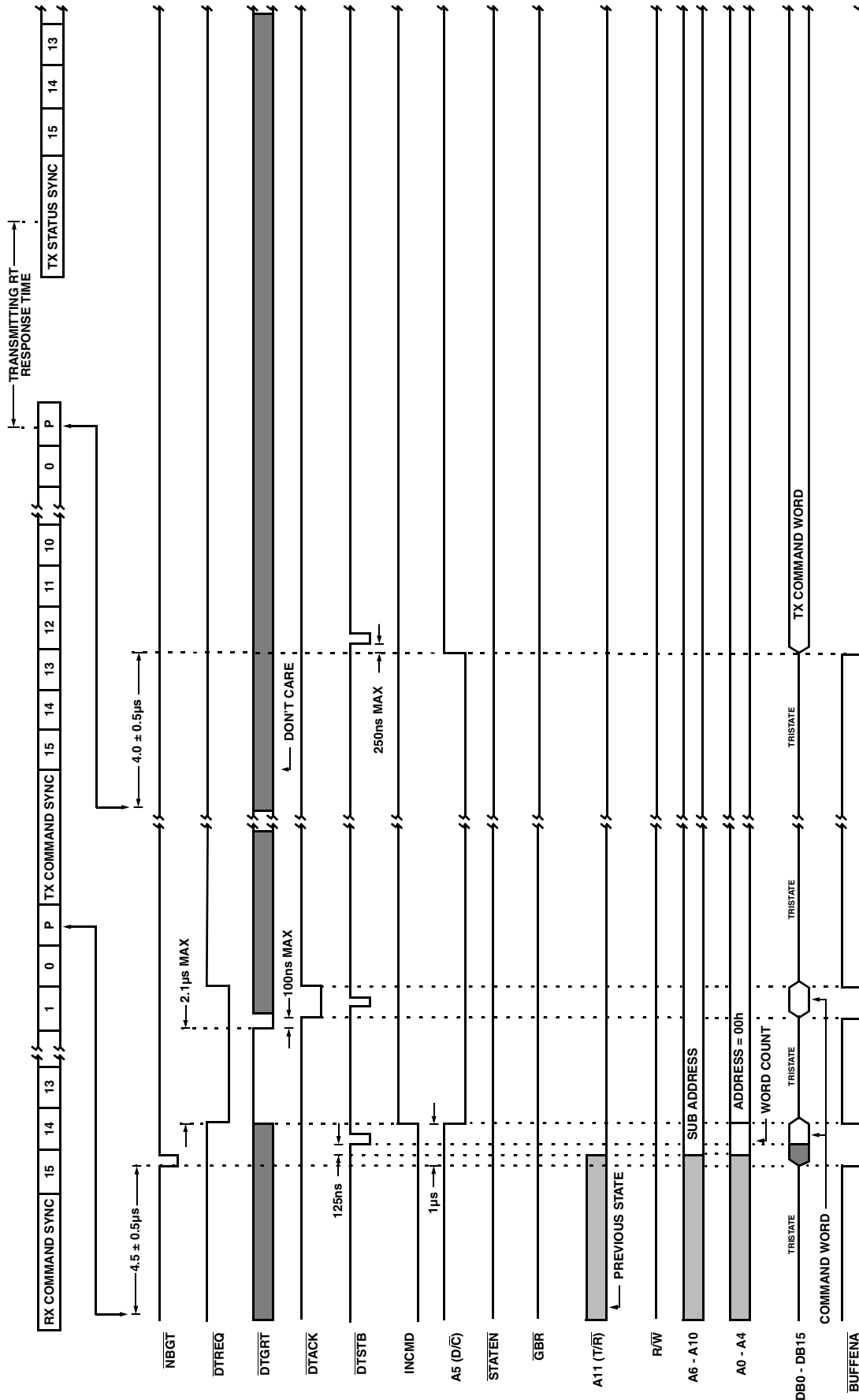

FIGURE 5A – TIMING DIAGRAM, RT TO RT RECEIVE ONE WORD (PART A)

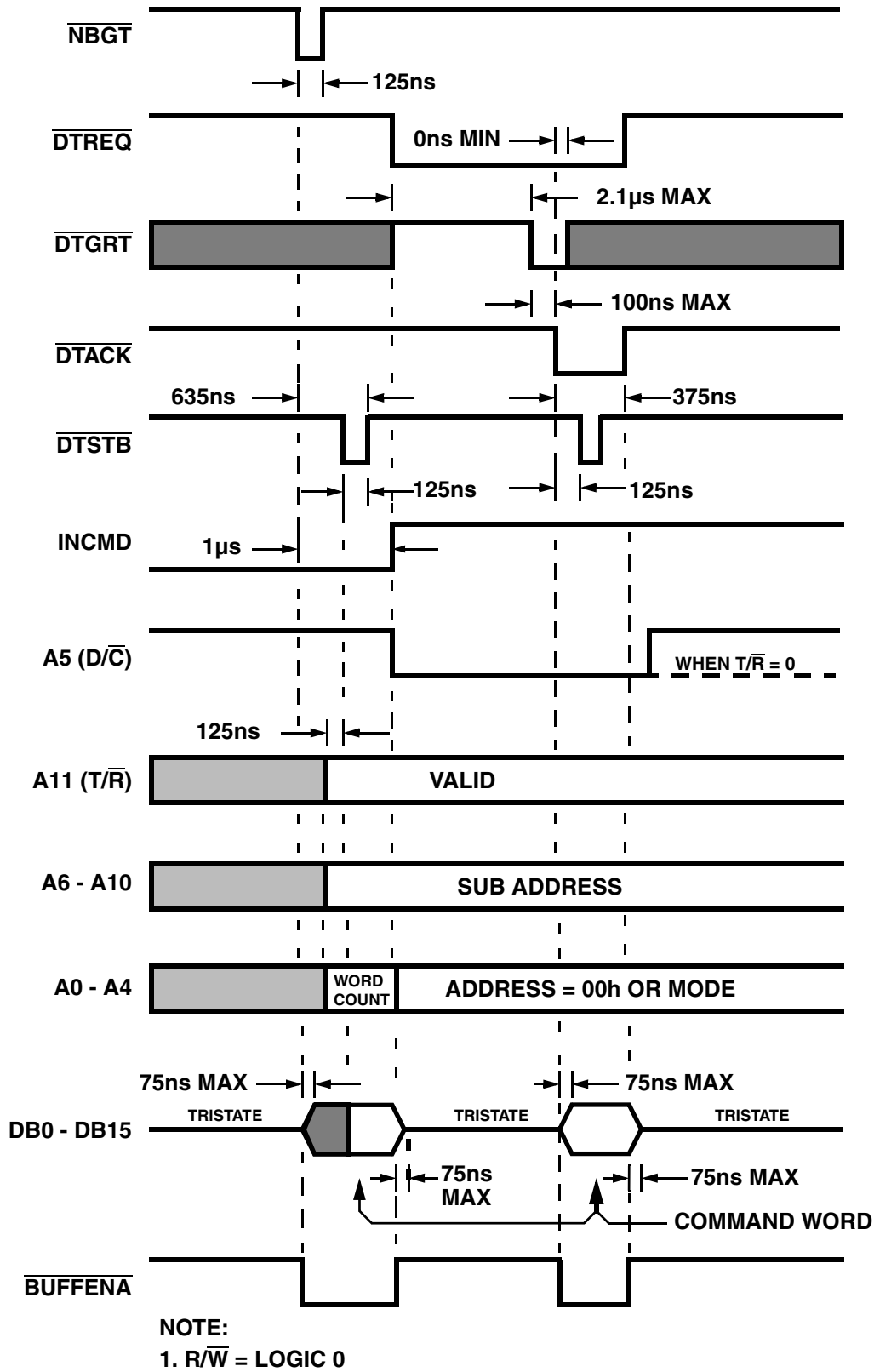
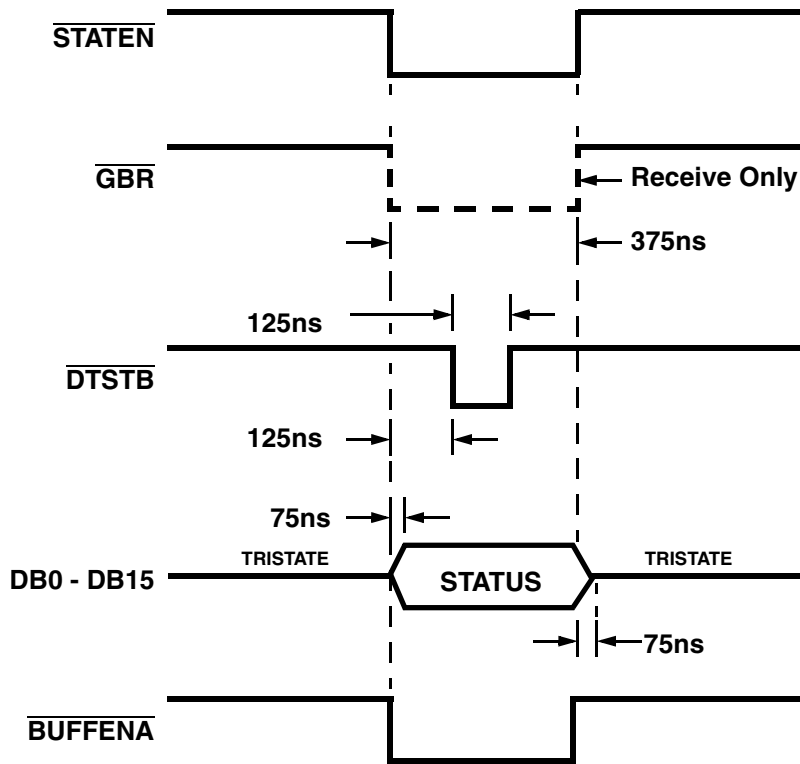
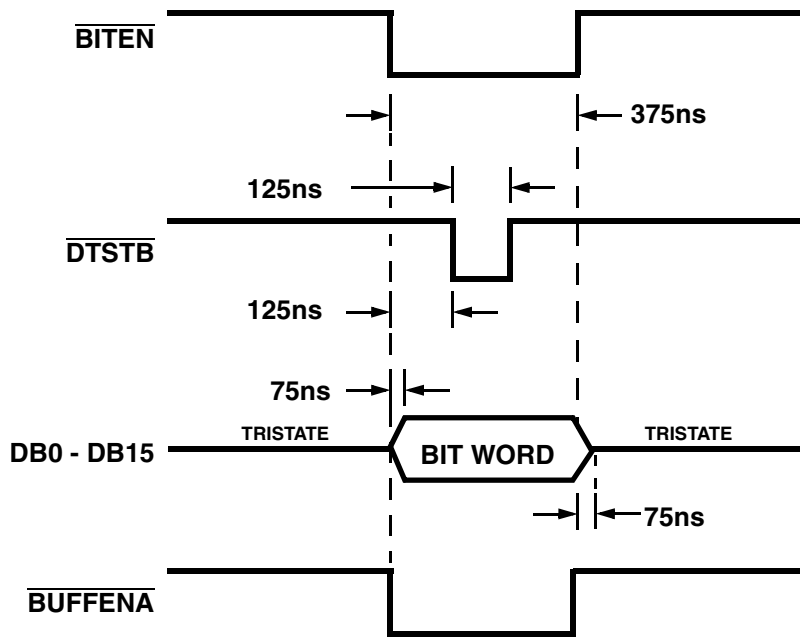

FIGURE 6 – TIMING DIAGRAM, COMMAND WORD TRANSFER



NOTE:
1. $R/\overline{W} = 0$

FIGURE 7 – TIMING DIAGRAM, STATUS WORD TRANSFER



NOTE:
1. $R/\overline{W} = 0$

FIGURE 8 – TIMING DIAGRAM, BIT WORD TRANSFER

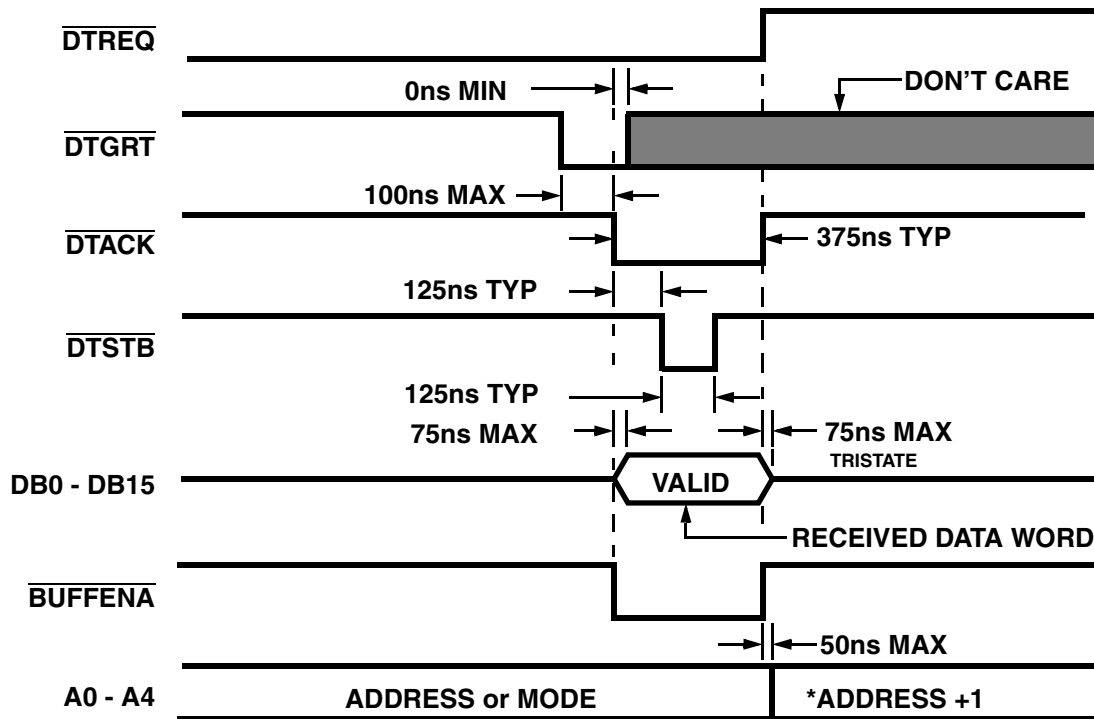

1. R/\overline{W} = Logic 0
2. (*) = Non-Mode Only
3. $\overline{BUFFENA}$ = \overline{DTACK}

FIGURE 9 – TIMING DIAGRAM, DATA TO SUBSYSTEM

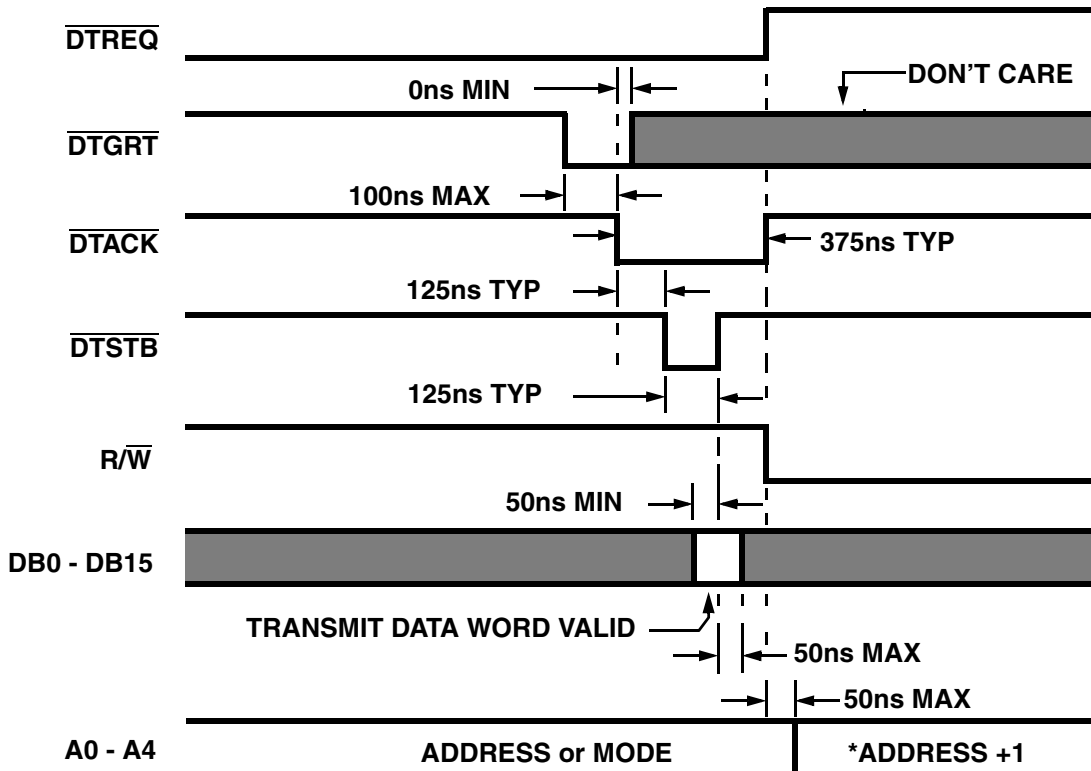

1. (*) = Non-Mode Only
2. Word Count for Mode Code
3. $\overline{BUFFENA}$ = Don't Care

FIGURE 10 – TIMING DIAGRAM, DATA FROM SUBSYSTEM

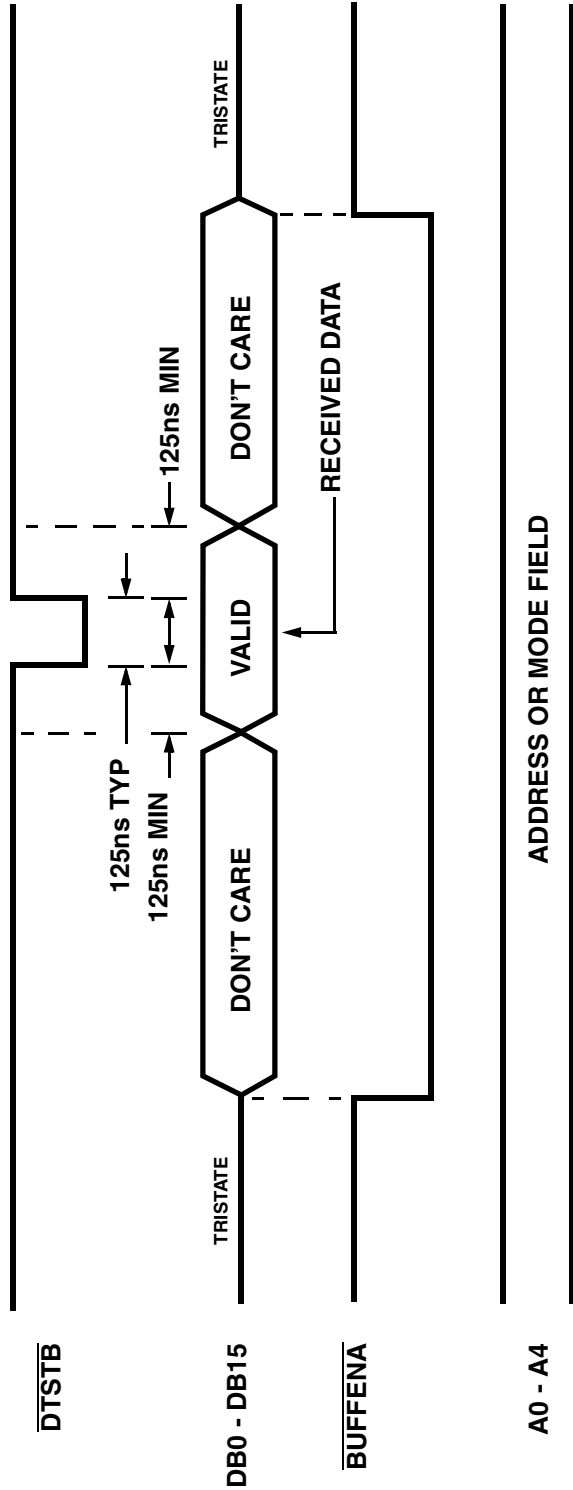

NOTES:

1. R/\overline{W} = LOGIC 0
2. \overline{DTGRT} = \overline{DTREQ} = LOGIC 1
3. \overline{INCMD} = $\overline{DAT/CMD}$ ARE LOGIC 1

FIGURE 11 – TIMING DIAGRAM, DATA TRANSFERS TO SUBSYSTEM (NO HANDSHAKE)

CT2542 PIN OUT DESCRIPTION (DDIP)

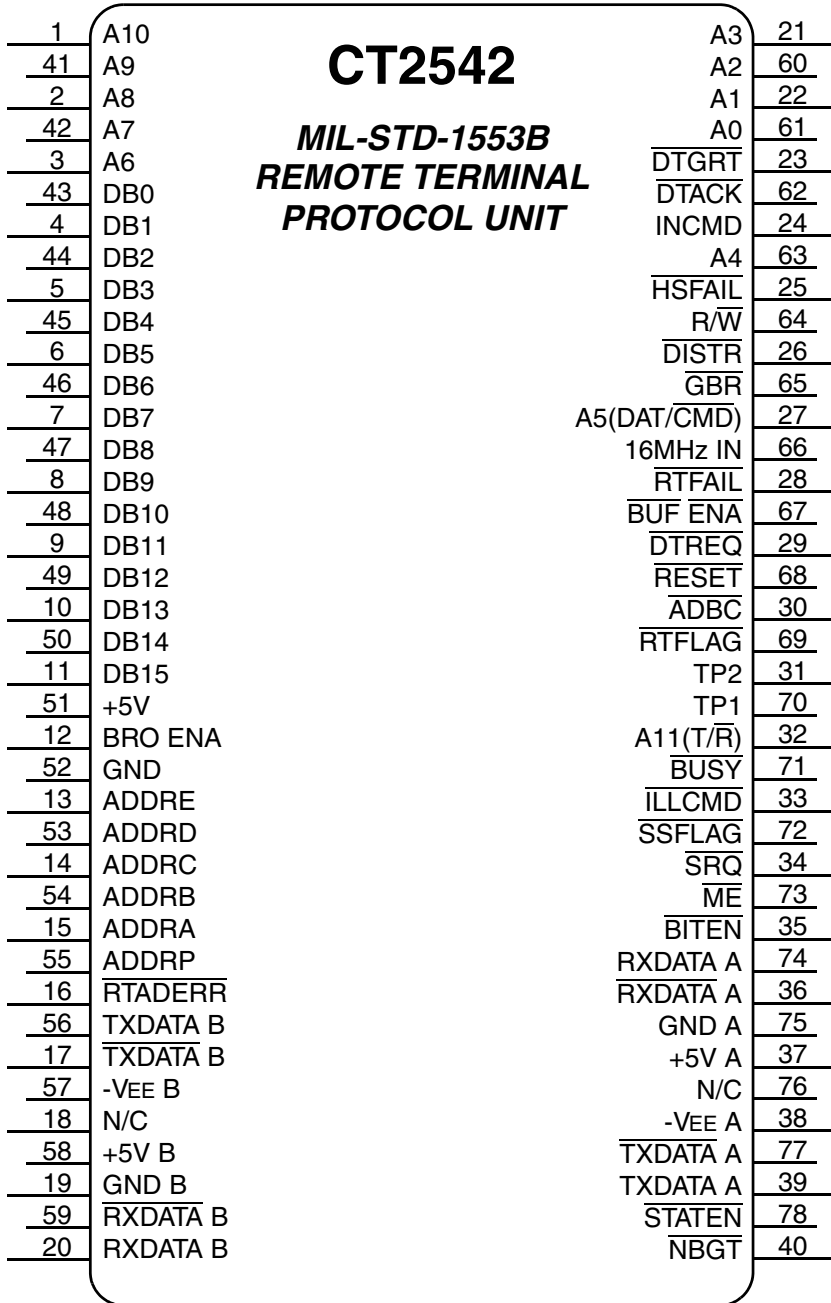

Pin #	Function	Pin #	Function
1	A10	40	NBGT
2	A8	41	A9
3	A6	42	A7
4	DB1	43	DB0
5	DB3	44	DB2
6	DB5	45	DB4
7	DB7	46	DB6
8	DB9	47	DB8
9	DB11	48	DB10
10	DB13	49	DB12
11	DB15	50	DB14
12	BRO ENA	51	+5V
13	ADDRE	52	GND
14	ADDRC	53	ADDRD
15	ADDRA	54	ADDRB
16	RTADERR	55	ADDRP
17	TXDATA B	56	TXDATA B
18	N/C	57	-VEE B
19	GND B	58	+5V B
20	RXDATA B	59	RXDATA B
21	A3	60	A2
22	A1	61	A0
23	DTGRT	62	DTACK
24	INCMD	63	A4
25	HSFAIL	64	R/W
26	DTSTR	65	GBR
27	A5 (DAT/CMD)	66	16MHz IN
28	RTFAIL	67	BUF ENA
29	DTREQ	68	RESET
30	ADBC	69	RTFLAG
31	TP2 (NC)	70	TP1 (NC)
32	A11 (T/R)	71	BUSY
33	ILLCMD	72	SSFLAG
34	SRQ	73	ME
35	BITEN	74	RXDATA A
36	RXDATA A	75	GND A
37	+5V A	76	N/C
38	-VEE A	77	TXDATA A
39	TXDATA A	78	STATEN

FIGURE 12 – DDIP PIN CONNECTION DIAGRAM, CT2542 AND PINOUT TABLE

CT2512 PIN OUT DESCRIPTION (FP)

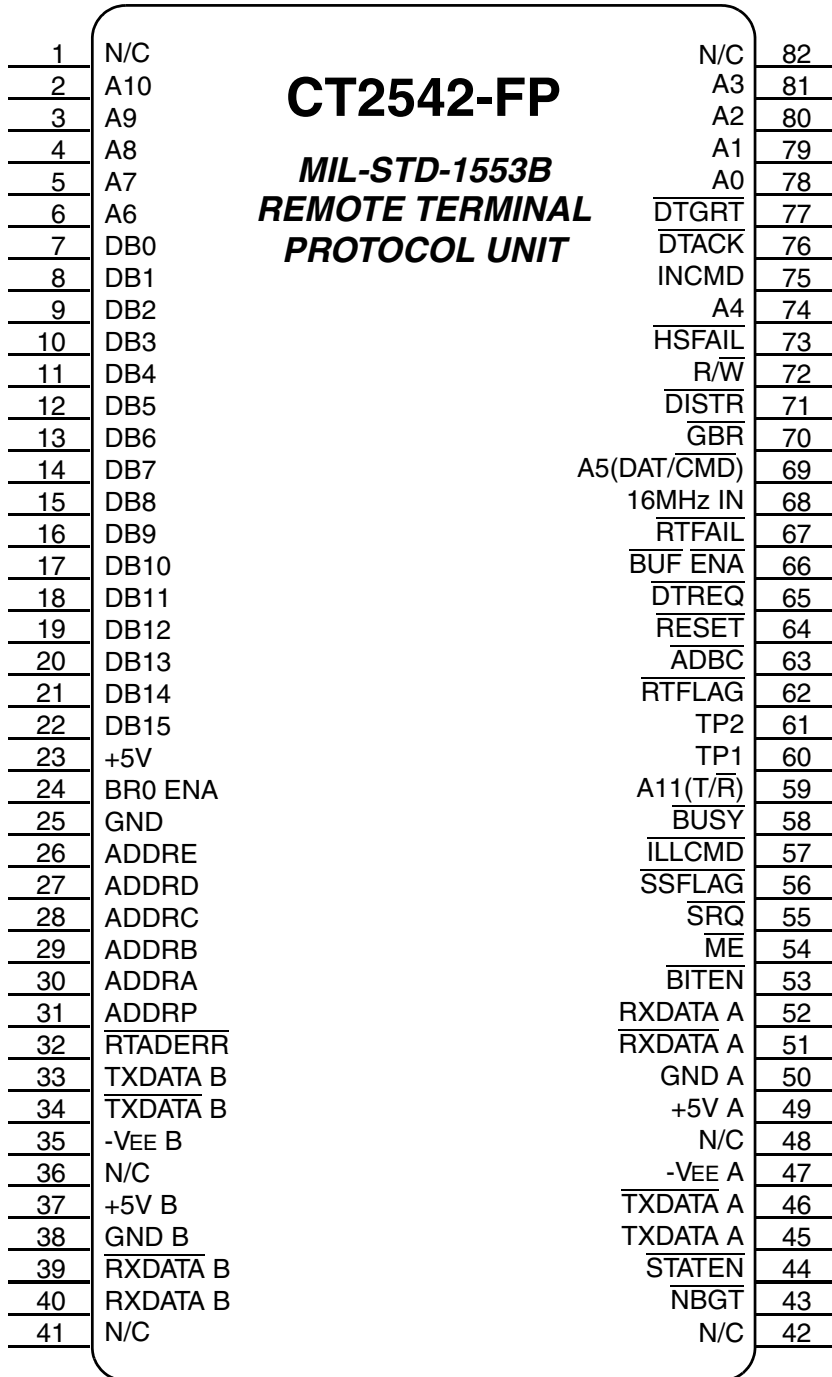

Pin #	Function	Pin #	Function
1	NC	42	NC
2	A10	43	NBGT
3	A9	44	STATEN
4	A8	45	TXDATA A
5	A7	46	TXDATA A
6	A6	47	VEE A
7	DB0	48	N/C
8	DB1	49	+5V A
9	DB2	50	GND A
10	DB3	51	RXDATA A
11	DB4	52	RXDATA A
12	DB5	53	BITEN
13	DB6	54	ME
14	DB7	55	SRQ
15	DB8	56	SSFLAG
16	DB9	57	ILLCMD
17	DB10	58	BUSY
18	DB11	59	A11 (T/R)
19	DB12	60	TP1
20	DB13	61	TP2
21	DB14	62	RTFLAG
22	DB15	63	ADBC
23	+5V	64	RESET
24	BRO ENA	65	DTREQ
25	GND	66	BUF ENA
26	ADDRE	67	RTFAIL
27	ADDRD	68	16MHz IN
28	ADDRC	69	A5 (DAT/CMD)
29	ADDRB	70	GBR
30	ADDRA	71	DTSTR
31	ADDRP	72	R/W
32	RTADERR	73	HSFAIL
33	TXDATA B	74	A4
34	TXDATA B	75	INCMD
35	-VEE B	76	DTACK
36	N/C	77	DTGRT
37	+5V B	78	A0
38	GND B	79	A1
39	RXDATA B	80	A2
40	RXDATA B	81	A3
41	NC	82	NC

FIGURE 13 – FLAT PACKAGE PIN CONNECTION DIAGRAM, CT2542 AND PINOUT TABLE

PLUG IN PACKAGE OUTLINE

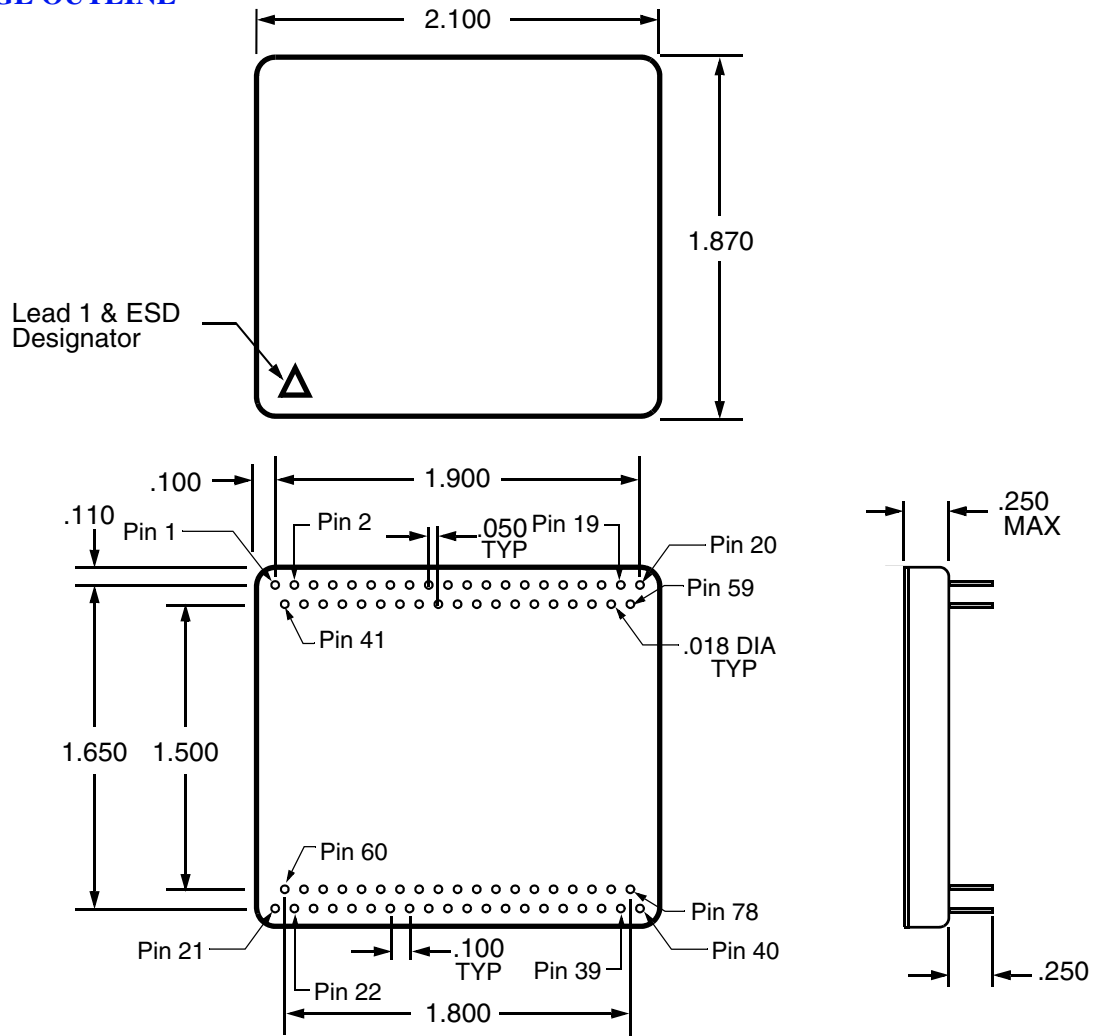

FLAT PACKAGE OUTLINE

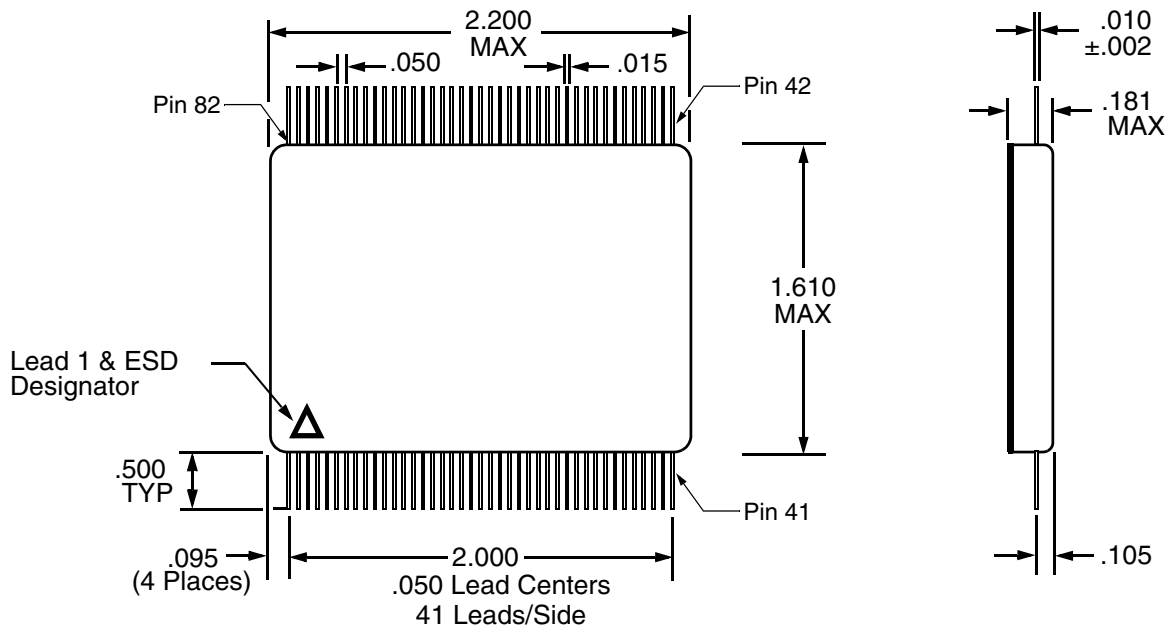

ORDERING INFORMATION

Model Number	Screening	Power Supplies	DESC SMD #	Package
CT2542	Military Temperature, -55°C to +125°C, Screened to the individual test methods of MIL-STD-883	+5V & -15V	-	Plug in
CT2542-FP				Flat Package
CT2542-701	Industrial Temperature, -40°C to +85°C, No Burn-in			Plug in
CT2542-FP-701				Flat Package
CT2542-001-2	-		5962-8979803XA	Plug in
CT2542-001-1			5962-8979803XC	
CT2542-201-2			5962-8979803YA	Flat Package
CT2542-201-1			5962-8979803YC	
CT2543	Military Temperature, -55°C to +125°C, Screened to the individual test methods of MIL-STD-883	+5V & -12V	-	Plug in
CT2543-FP				Flat Package
CT2543-701	Industrial Temperature, -40°C to +85°C, No Burn-in			Plug in
CT2543-FP-701				Flat Package
CT2543-001-2	-		5962-8979804XA	Plug in
CT2543-001-1			5962-8979804XC	
CT2543-201-2			5962-8979804YA	Flat Package
CT2543-201-1			5962-8979804YC	

PLAINVIEW, NEW YORK
Toll Free: 800-THE-1553
Fax: 516-694-6715

INTERNATIONAL
Tel: 805-778-9229
Fax: 805-778-1980

NORTHEAST
Tel: 603-888-3975
Fax: 603-888-4585

SE AND MID-ATLANTIC
Tel: 321-951-4164
Fax: 321-951-4254

WEST COAST
Tel: 949-362-2260
Fax: 949-362-2266

CENTRAL
Tel: 719-594-8017
Fax: 719-594-8468

www.aeroflex.com info-ams@aeroflex.com



Aeroflex Microelectronic Solutions reserves the right to change at any time without notice the specifications, design, function, or form of its products described herein. All parameters must be validated for each customer's application by engineering. No liability is assumed as a result of use of this product. No patent licenses are implied.



Our passion for performance is defined by three attributes represented by these three icons: solution-minded, performance-driven and customer-focused