

DN8643S

24-bit Shift Register Latch Driver IC

Overview

The DN8643S is an IC which incorporates a 24-bit shift register and a latch driver to meet high-speed operation, low power consumption and high-density printout of the thermal printers for the work processors, and so on. It employs the Bi-CMOS process in which the serial-in and serial-out/parallel-out functions are incorporated, the 24-step shift register block and latch block are composed of CMOS, and the 24-step parallel driver block is bipolar.

Features

- Serial-in and serial-out/parallel-out
- Cascade connection allowed
- Built-in output malfunctioning preventive circuit
- Low current at standby $I_{CC} \leq 100\mu A$
- High-breakdown, large current drive type output steps
Breakdown : 30V
Output current : 120mA
- Surface mountable USONF-36D package (pin pitch : 0.8mm)

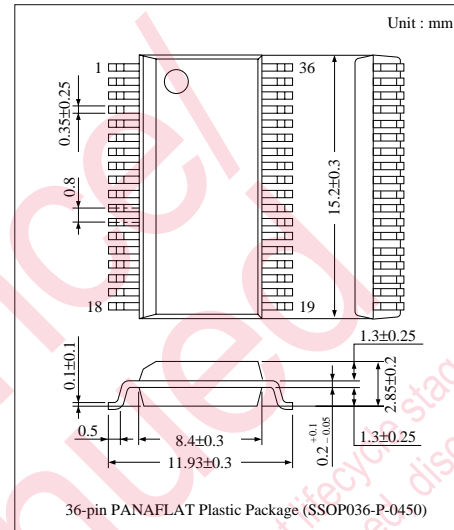

Block Diagram

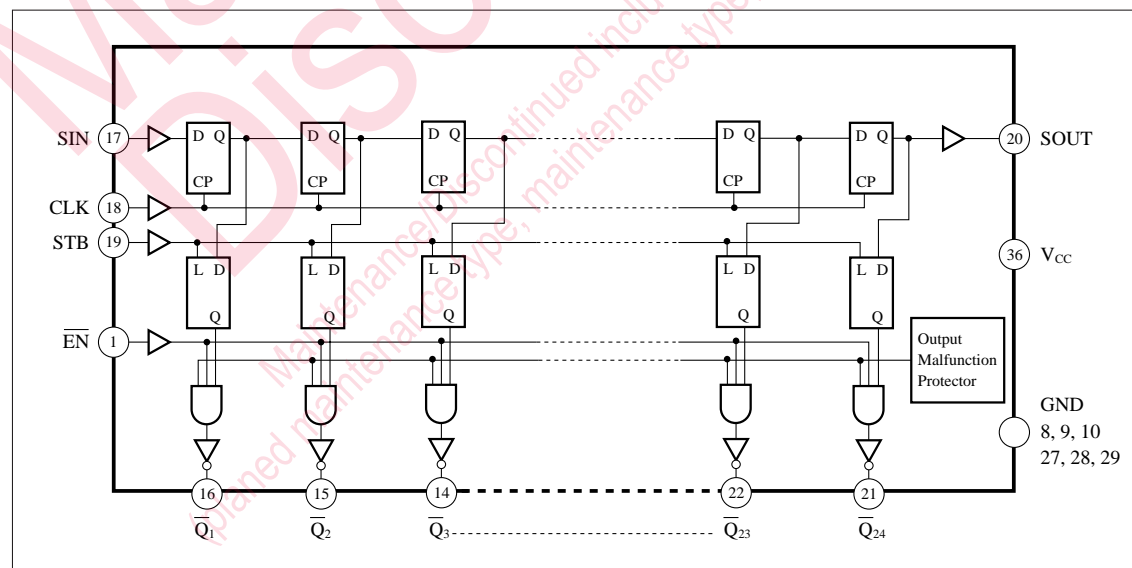

■ Absolute Maximum Ratings (Ta=25°C)

Parameter	Symbol	Rating	Unit
Supply voltage	V _{CC}	0 to 7	V
Output voltage	V _O	0 to 30	V
Output current	I _O	120	mA
Power dissipation	P _D	1.3 *	W
Operating ambient temperature	T _{opr}	-20 to + 75	°C
Storage temperature	T _{stg}	-55 to + 125	°C

* When mounting onto the PCB, power dissipation is reduced at a rate of 10.4mW/°C from Ta=25°C

■ Recommended Operating Range (Ta=25°C)

Parameter	Symbol	Condition	min	typ	max	Unit
Supply voltage	V _{CC}		4	5	6	V
Output voltage	V _O		—	—	30	V
Output current *	I _O		—	—	100	mA
Clock frequency	f _{CLK}	Input Duty 40 to 60%	—	—	10	MHz
Input pulse width	CLK	t _w	40	—	—	ns
	STB		40	—	—	ns
Setup time	SIN	t _{su}	30	—	—	ns
	STB		40	—	—	ns
Hold time	SIN	t _h	20	—	—	ns
	STB		0	—	—	ns
Clock pulse rise time	t _r		—	—	500	ns
Clock pulse fall time	t _f		—	—	500	ns

* An allowable value changes depends on the number of simultaneously turned-on circuits and the duty. Use with power dissipation taken into full account.

■ Electrical Characteristics (Ta=25°C)

Parameter	Symbol	Condition	min	typ	max	Unit
Input voltage	V _{IH}	V _{CC} =4 to 6V	0.7V _{CC}	—	V _{CC}	V
	V _{IL}		0	—	0.3V _{CC}	V
Input current	I _{IH}	V _{IH} =5V	—	—	25	μA
	I _{IL}	V _{IL} =0V	—	—	-25	μA
Output voltage	V _{OH}	I _O =-1μA	4.9	—	—	V
	V _{OL}	I _O =1μA	—	—	0.1	V
Output current	I _{OH}	V _{OH} =4.5V	-4	—	—	mA
	I _{OL}	V _{OL} =0.4V	4	—	—	mA
Output saturation voltage	V _{CE(sat)1}	I _{OL} =100mA	—	—	0.4	V
	V _{CE(sat)2}	I _{OL} =80mA	—	—	0.35	V
Output leakage current	I _{OLK1}	V _O =30V (output OFF)	—	—	50	μA
	I _{OLK2}	V _O =15V (output Off)	—	—	25	μA
Supply current	I _{CC1}	Total driver output OFF	—	—	100	μA
	I _{CC2}	Driver output 1 circuit ON	—	—	5	mA
Output malfunctioning preventive circuit operating voltage *	V _{CCT+}		2.9	—	3.9	V
	V _{CCT-}		2.6	—	3.6	V

* Output malfunctioning preventive circuit operating voltage timing chart

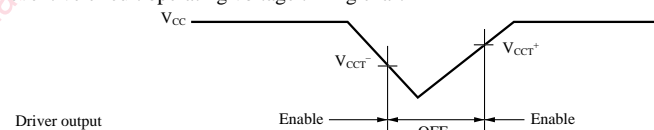

■ Switching Characteristics (Ta=25°C)

Parameter	Symbol	Input	Output	Condition	min	typ	max	Unit
Maximum clock frequency	f_{\max}	CLK			10	—	—	MHz
Propagation delay time	t_{PLH}	CLK	SOUT	$V_{CC}=5V$ $C_L=15pF$	—	—	100	ns
	t_{PHL}				—	—	100	ns
	t_{PLH}	CLK	$\bar{Q}n$	$V_{CC}=5V$ $R_L=100\Omega$	—	—	2	μs
	t_{PHL}				—	—	0.5	μs
	t_{PLH}	$\bar{E}N$	$\bar{Q}n$	$C_L=15pF$	—	—	2	μs
	t_{PHL}				—	—	0.5	μs

■ Timing Chart

1. Input Timing

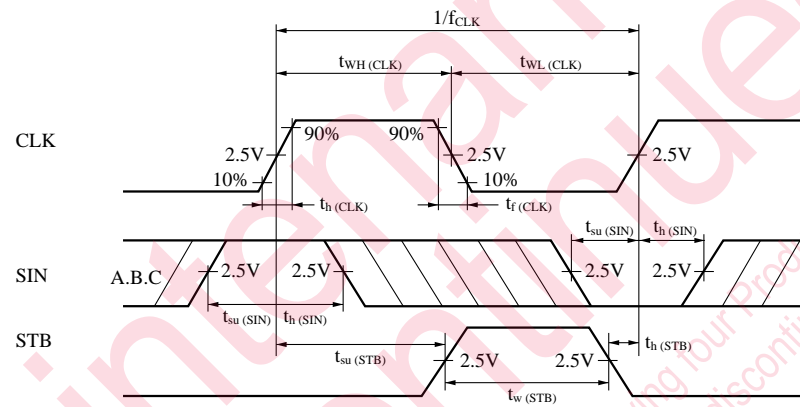

2. Propagation Delay Time

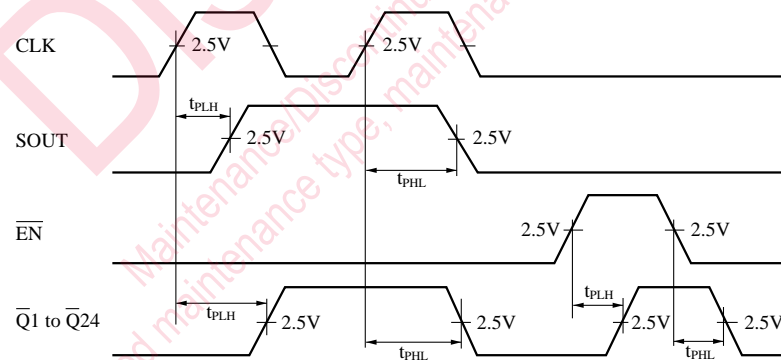

■ Pin Assignments

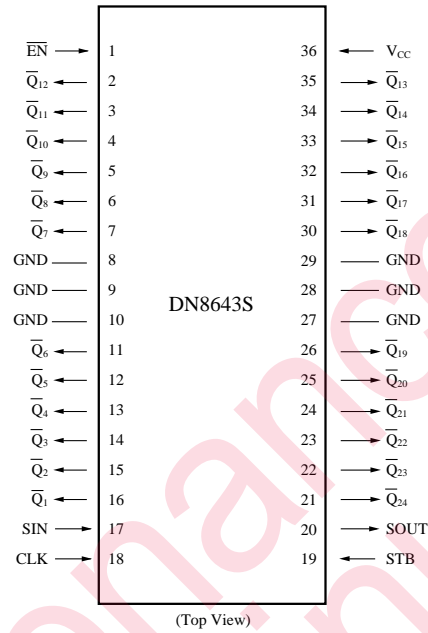

■ Functions Table

Input				Driver output		SOUT
CLK	\overline{EN}	STB	SIN	\overline{Q}_1	\overline{Q}_n	
↑	H	×	×	H	H	Q'_{23}
↓	H	×	×	H	H	nc
↑	L	L	×	nc	nc	Q'_{23}
↑	L	H	L	H	\overline{Q}_{n-1}	Q'_{23}
↑	L	H	H	L	\overline{Q}_{n-1}	Q'_{23}
↓	L	H	×	nc	nc	nc

Note) H=High level, L=Low level, × = Either "H" or "L" will do, ↑ = Transition from "H" or "L", ↓ = Transition from "H" to "L", nc=No change, Q'_{23} =Status of the 23rd shift register

Request for your special attention and precautions in using the technical information and semiconductors described in this book

- (1) If any of the products or technical information described in this book is to be exported or provided to non-residents, the laws and regulations of the exporting country, especially, those with regard to security export control, must be observed.
- (2) The technical information described in this book is intended only to show the main characteristics and application circuit examples of the products, and no license is granted under any intellectual property right or other right owned by our company or any other company. Therefore, no responsibility is assumed by our company as to the infringement upon any such right owned by any other company which may arise as a result of the use of technical information described in this book.
- (3) The products described in this book are intended to be used for standard applications or general electronic equipment (such as office equipment, communications equipment, measuring instruments and household appliances).
Consult our sales staff in advance for information on the following applications:
 - Special applications (such as for airplanes, aerospace, automobiles, traffic control equipment, combustion equipment, life support systems and safety devices) in which exceptional quality and reliability are required, or if the failure or malfunction of the products may directly jeopardize life or harm the human body.
 - Any applications other than the standard applications intended.
- (4) The products and product specifications described in this book are subject to change without notice for modification and/or improvement. At the final stage of your design, purchasing, or use of the products, therefore, ask for the most up-to-date Product Standards in advance to make sure that the latest specifications satisfy your requirements.
- (5) When designing your equipment, comply with the range of absolute maximum rating and the guaranteed operating conditions (operating power supply voltage and operating environment etc.). Especially, please be careful not to exceed the range of absolute maximum rating on the transient state, such as power-on, power-off and mode-switching. Otherwise, we will not be liable for any defect which may arise later in your equipment.
 - Even when the products are used within the guaranteed values, take into the consideration of incidence of break down and failure mode, possible to occur to semiconductor products. Measures on the systems such as redundant design, arresting the spread of fire or preventing glitch are recommended in order to prevent physical injury, fire, social damages, for example, by using the products.
- (6) Comply with the instructions for use in order to prevent breakdown and characteristics change due to external factors (ESD, EOS, thermal stress and mechanical stress) at the time of handling, mounting or at customer's process. When using products for which damp-proof packing is required, satisfy the conditions, such as shelf life and the elapsed time since first opening the packages.
- (7) This book may be not reprinted or reproduced whether wholly or partially, without the prior written permission of Matsushita Electric Industrial Co., Ltd.