

5 AMP POSITIVE VOLTAGE REGULATOR

FEATURES

- Low Dropout Performance
- Fixed or Adjustable Voltages
- Fixed Output Voltages of 3.3V, 5V & 12V
- Adjustable Output Voltage Range From 1.2V
- Line Regulation 0.015% / V Typical.
- Load Regulation 0.01% Typical.
- Available in Hermetically Sealed TO-3, SMD1 and TO-257 (isolated & non-isolated) Packages.
- Military Temperature Range (-55 to +150°C)

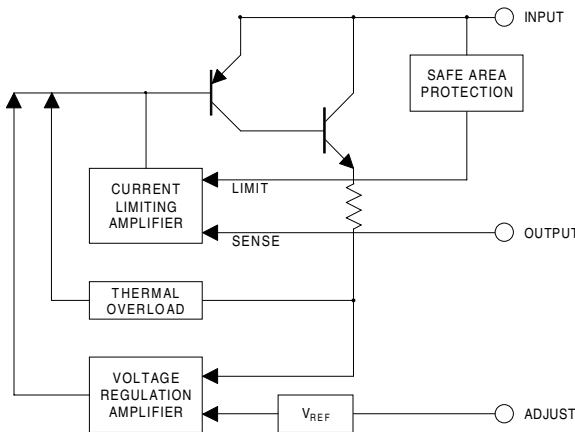

DESCRIPTION

The LT1084 voltage regulators are monolithic integrated circuits designed for use in applications requiring a well regulated positive output voltage with low input-output differential voltage.

Features include full power usage of up to 5A load current, internal current limiting and thermal shutdown. Safe area protection on the die is also included, providing protection of the series pass Darlington transistor under most conditions.

The hermetically sealed TO-3 packages are utilised for high reliability and low thermal resistance, whilst the SMD1 package is designed for surface mount applications.

ABSOLUTE MAXIMUM RATINGS (T_{case} = 25°C unless otherwise stated)

V _{IN}	Input – Output Voltage Differential			35V
P _D	Power Dissipation			Internally limited *
R _{θJC}	Thermal Resistance Junction To Case	TO-3	Control	0.76°C / W
		TO-3	Power	2.3°C / W
R _{θJC}	Thermal Resistance Junction To Case	SMD1	Control	0.79°C / W
		SMD1	Power	4.0°C / W
R _{θJC}	Thermal Resistance Junction To Case	TO-257	Control	0.79°C / W
		TO-257	Power	4.0°C / W
T _J	Operating Junction Temperature Range		Control	-55 to 150°C
			Power	-55 to 200°C
T _{STG}	Storage Temperature Range			-65 to 150°C
T _{LEAD}	Lead Temperature (for 10 sec.)			300°C

* These ratings are only applicable for power dissipations of 30 Watts over a limited range of V_{IN} – V_{OUT}.

Semelab Plc reserves the right to change test conditions, parameter limits and package dimensions without notice. Information furnished by Semelab is believed to be both accurate and reliable at the time of going to press. However Semelab assumes no responsibility for any errors or omissions discovered in its use. Semelab encourages customers to verify that datasheets are current before placing orders.

Semelab plc. Telephone +44(0)1455 556565. Fax +44(0)1455 552612.

E-mail: sales@semelab.co.uk Website: <http://www.semelab.co.uk>

Document Number 6386

Issue 1

ELECTRICAL CHARACTERISTICS ($T_J = 25^\circ\text{C}$ Unless otherwise stated) **LT1084MK & LT1084MSM**

Parameter	Output Voltage	Test Conditions ^{1,2}		Min.	Typ.	Max.	Unit
V_O ⁴ Output Voltage	3.3	$V_{IN} - V_{OUT} = 6.3\text{V}$	$I_O = 10\text{mA}$	3.267	3.3	3.333	V
		$I_O = 10\text{mA to } 5\text{A}$	$T_J = \text{Over Temp } ^3$	3.234	3.3	3.366	
	5	$V_{IN} - V_{OUT} = 8\text{V}$	$I_O = 10\text{mA}$	4.95	5	5.05	
		$I_O = 10\text{mA to } 5\text{A}$	$T_J = \text{Over Temp } ^3$	4.90	5	5.10	
	12	$V_{IN} - V_{OUT} = 15\text{V}$	$I_O = 10\text{mA}$	11.88	12	12.12	
		$I_O = 10\text{mA to } 5\text{A}$	$T_J = \text{Over Temp } ^3$	11.76	12	12.24	
V_{REF} ⁴ Reference Voltage	ADJ.	$V_{IN} - V_{OUT} = V_O + 3\text{V}$	$I_O = 10\text{mA}$	1.238	1.25	1.262	V
		$I_O = 10\text{mA to } 5\text{A}$	$T_J = \text{Over Temp } ^3$	1.225	1.25	1.270	
$REG_{(LINE)}$ ⁴ Line Regulation		$V_{IN} - V_{OUT} = 1.5 \text{ to } 15\text{V}$ $I_O = 10\text{mA}$	$T_J = 25^\circ\text{C}$		0.015	0.2	%
			$T_J = \text{Over Temp } ^3$		0.035		
		$V_{IN} - V_{OUT} = 1.5 \text{ to } 35\text{V}$ $T_J = \text{Over Temp } ^3$	$I_O = 10\text{mA}$		0.05	0.5	%
$REG_{(LOAD)}$ ⁴ Load Regulation		$V_{IN} - V_{OUT} = 3\text{V}$	$T_J = 25^\circ\text{C}$		0.1	0.3	%
		$V_{IN} - V_{OUT} = 3\text{V}$	$T_J = \text{Over Temp } ^3$		0.2	0.4	
V_D Dropout Voltage		$\Delta V_{OUT}, \Delta V_{REF} = 1\%$	$T_J = \text{Over Temp } ^3$		1.3	1.5	V
I_{CL} Current Limit		$V_{IN} - V_{OUT} = 5\text{V}$	$T_J = \text{Over Temp } ^3$	5.5	6.5		A
		$V_{IN} - V_{OUT} = 25\text{V}$	$T_J = \text{Over Temp } ^3$	0.3		0.6	
I_Q Quiescent Current		$V_{IN} - V_{OUT} = 35\text{V}$	$T_J = \text{Over Temp } ^3$			10	mA
$REG_{(THERM)}$ Thermal Regulation		$t_p = 30\text{ms}$	$T_J = 25^\circ\text{C}$		0.002	0.01	% / W
I_{PIN} Adjust Pin Current		$T_J = 25^\circ\text{C}$			55		μA
		$T_J = \text{Over Temp } ^3$				120	
ΔI_{PIN} Adjust Pin Current Change		$T_J = \text{Over Temp } ^3$			0.2	5	μA
T_S Temperature Stability		$V_{IN} - V_{OUT} = 5\text{V}$	$I_O = 0.5\text{A}$		0.5		%
		$T_J = \text{Over Temp } ^3$					
I_O Minimum Load Current		$V_{IN} - V_{OUT} = 25\text{V}$	$I_O = 0.5\text{A}$		5	10	mA
		$T_J = \text{Over Temp } ^3$					
V_N RMS Output Noise ⁵		$T_J = 25^\circ\text{C}$			0.003		% V_O
R_A Ripple Rejection Ratio ⁶		$V_{IN} - V_{OUT} = 3\text{V}$	$I_O = 3\text{A}$	60	75		dB
		$T_J = \text{Over Temp } ^3$					

1. Test Conditions unless otherwise stated: $V_{IN} = 1.5 \text{ to } 35\text{V}$, or Maximum Input, whichever is less.
 $I_O = 10\text{mA to } 5\text{A}$.
2. These specifications are only applicable for power dissipations of 45 Watts over a limited range of $V_{IN} - V_{OUT}$.
3. Over Temp. = Over specified Junction Temperature Range (See Absolute Maximum Ratings).
4. Low duty cycle pulse test with Kelvin connections required. Changes in output voltage are covered under the specification for thermal regulation.
5. Bandwidth of 10Hz to 10kHz.
6. 120Hz input ripple, 15V = 64dB min. $C_{OUT} (C_{ADJ}) = 25\mu\text{F}$.

Semelab Plc reserves the right to change test conditions, parameter limits and package dimensions without notice. Information furnished by Semelab is believed to be both accurate and reliable at the time of going to press. However Semelab assumes no responsibility for any errors or omissions discovered in its use. Semelab encourages customers to verify that datasheets are current before placing orders.

Semelab plc. Telephone +44(0)1455 556565. Fax +44(0)1455 552612.

E-mail: sales@semelab.co.uk Website: <http://www.semelab.co.uk>

Document Number 6386

Issue 1

ELECTRICAL CHARACTERISTICS ($T_J = 25^\circ\text{C}$ Unless otherwise stated) **LT1084MG**

Parameter	Output Voltage	Test Conditions ^{1,2}	Min.	Typ.	Max.	Unit
V_O ⁴ Output Voltage	3.3	$V_{IN} - V_{OUT} = 6.3\text{V}$ $I_O = 10\text{mA}$	3.267	3.3	3.333	V
		$I_O = 10\text{mA to } 5\text{A}$ $T_J = \text{Over Temp}^3$	3.234	3.3	3.366	
	5	$V_{IN} - V_{OUT} = 8\text{V}$ $I_O = 10\text{mA}$	4.95	5	5.05	
		$I_O = 10\text{mA to } 5\text{A}$ $T_J = \text{Over Temp}^3$	4.90	5	5.10	
	12	$V_{IN} - V_{OUT} = 15\text{V}$ $I_O = 10\text{mA}$	11.88	12	12.12	
		$I_O = 10\text{mA to } 5\text{A}$ $T_J = \text{Over Temp}^3$	11.76	12	12.24	
V_{REF} ⁴ Reference Voltage	ADJ.	$V_{IN} - V_{OUT} = V_O + 3\text{V}$ $I_O = 10\text{mA}$	1.238	1.25	1.262	V
		$I_O = 10\text{mA to } 5\text{A}$ $T_J = \text{Over Temp}^3$	1.225	1.25	1.270	
$REG_{(LINE)}$ ⁴ Line Regulation		$V_{IN} - V_{OUT} = 1.5 \text{ to } 15\text{V}$ $I_O = 10\text{mA}$	$T_J = 25^\circ\text{C}$	0.015	0.2	%
			$T_J = \text{Over Temp}^3$	0.035		
		$V_{IN} - V_{OUT} = 1.5 \text{ to } 35\text{V}$ $T_J = \text{Over Temp}^3$	$I_O = 10\text{mA}$	0.05	0.5	%
$REG_{(LOAD)}$ ⁴ Load Regulation		$V_{IN} - V_{OUT} = 3\text{V}$ $T_J = 25^\circ\text{C}$		0.4	0.5	%
		$V_{IN} - V_{OUT} = 3\text{V}$ $T_J = \text{Over Temp}^3$		0.7	0.6	
V_D Dropout Voltage		$\Delta V_{OUT}, \Delta V_{REF} = 1\%$ $T_J = \text{Over Temp}^3$		1.3	1.5	V
I_{CL} Current Limit		$V_{IN} - V_{OUT} = 5\text{V}$ $T_J = \text{Over Temp}^3$	5.5	6.5		A
		$V_{IN} - V_{OUT} = 25\text{V}$ $T_J = \text{Over Temp}^3$	0.3		0.6	
I_Q Quiescent Current		$V_{IN} - V_{OUT} = 35\text{V}$ $T_J = \text{Over Temp}^3$			10	mA
$REG_{(THERM)}$ Thermal Regulation		$t_p = 30\text{ms}$ $T_J = 25^\circ\text{C}$		0.002	0.01	% / W
I_{PIN} Adjust Pin Current		$T_J = 25^\circ\text{C}$		55		μA
		$T_J = \text{Over Temp}^3$			120	
ΔI_{PIN} Adjust Pin Current Change		$T_J = \text{Over Temp}^3$		0.2	5	μA
T_S Temperature Stability		$V_{IN} - V_{OUT} = 5\text{V}$ $I_O = 0.5\text{A}$ $T_J = \text{Over Temp}^3$		0.5		%
I_O Minimum Load Current		$V_{IN} - V_{OUT} = 25\text{V}$ $I_O = 0.5\text{A}$ $T_J = \text{Over Temp}^3$		5	10	mA
V_N RMS Output Noise ⁵		$T_J = 25^\circ\text{C}$		0.003		% V_O
R_A Ripple Rejection Ratio ⁶		$V_{IN} - V_{OUT} = 3\text{V}$ $I_O = 3\text{A}$ $T_J = \text{Over Temp}^3$	60	75		dB

1. Test Conditions unless otherwise stated: $V_{IN} = 1.5 \text{ to } 35\text{V}$, or Maximum Input, whichever is less.
 $I_O = 10\text{mA to } 5\text{A}$.
2. These specifications are only applicable for power dissipations of 45 Watts over a limited range of $V_{IN} - V_{OUT}$.
3. Over Temp. = Over specified Junction Temperature Range (See Absolute Maximum Ratings).
4. Low duty cycle pulse test with Kelvin connections required. Changes in output voltage are covered under the specification for thermal regulation.
5. Bandwidth of 10Hz to 10kHz.
6. 120Hz input ripple, 15V = 64dB min. $C_{OUT} (C_{ADJ}) = 25\mu\text{F}$.

Semelab Plc reserves the right to change test conditions, parameter limits and package dimensions without notice. Information furnished by Semelab is believed to be both accurate and reliable at the time of going to press. However Semelab assumes no responsibility for any errors or omissions discovered in its use. Semelab encourages customers to verify that datasheets are current before placing orders.

ELECTRICAL CHARACTERISTICS ($T_J = 25^\circ\text{C}$ Unless otherwise stated) **LT1084MIG**

Parameter	Output Voltage	Test Conditions ^{1,2}	Min.	Typ.	Max.	Unit
V_O ⁴ Output Voltage	3.3	$V_{IN} - V_{OUT} = 6.3\text{V}$ $I_O = 10\text{mA}$	3.267	3.3	3.333	V
		$I_O = 10\text{mA to } 5\text{A}$ $T_J = \text{Over Temp}^3$	3.234	3.3	3.366	
	5	$V_{IN} - V_{OUT} = 8\text{V}$ $I_O = 10\text{mA}$	4.95	5	5.05	
		$I_O = 10\text{mA to } 5\text{A}$ $T_J = \text{Over Temp}^3$	4.90	5	5.10	
	12	$V_{IN} - V_{OUT} = 15\text{V}$ $I_O = 10\text{mA}$	11.88	12	12.12	
		$I_O = 10\text{mA to } 5\text{A}$ $T_J = \text{Over Temp}^3$	11.76	12	12.24	
V_{REF} ⁴ Reference Voltage	ADJ.	$V_{IN} - V_{OUT} = V_O + 3\text{V}$ $I_O = 10\text{mA}$	1.231	1.25	1.268	V
		$I_O = 10\text{mA to } 5\text{A}$ $T_J = \text{Over Temp}^3$	1.219	1.25	1.281	
$REG_{(LINE)}$ ⁴ Line Regulation		$V_{IN} - V_{OUT} = 1.5 \text{ to } 15\text{V}$ $I_O = 10\text{mA}$	$T_J = 25^\circ\text{C}$	0.015	0.2	%
			$T_J = \text{Over Temp}^3$	0.035		
		$V_{IN} - V_{OUT} = 1.5 \text{ to } 35\text{V}$ $T_J = \text{Over Temp}^3$	$I_O = 10\text{mA}$	0.05	0.5	%
$REG_{(LOAD)}$ ⁴ Load Regulation		$V_{IN} - V_{OUT} = 3\text{V}$ $T_J = 25^\circ\text{C}$		0.7	1.25	%
		$V_{IN} - V_{OUT} = 3\text{V}$ $T_J = \text{Over Temp}^3$		0.8	1.65	
V_D Dropout Voltage		$\Delta V_{OUT}, \Delta V_{REF} = 1\%$ $T_J = \text{Over Temp}^3$		1.3	1.5	V
I_{CL} Current Limit		$V_{IN} - V_{OUT} = 5\text{V}$ $T_J = \text{Over Temp}^3$	5.5	6.5		A
		$V_{IN} - V_{OUT} = 25\text{V}$ $T_J = \text{Over Temp}^3$	0.3		0.6	
I_Q Quiescent Current		$V_{IN} - V_{OUT} = 35\text{V}$ $T_J = \text{Over Temp}^3$			10	mA
$REG_{(THERM)}$ Thermal Regulation		$t_p = 30\text{ms}$ $T_J = 25^\circ\text{C}$		0.002	0.01	% / W
I_{PIN} Adjust Pin Current		$T_J = 25^\circ\text{C}$		55		μA
		$T_J = \text{Over Temp}^3$			120	
ΔI_{PIN} Adjust Pin Current Change		$T_J = \text{Over Temp}^3$		0.2	5	μA
T_S Temperature Stability		$V_{IN} - V_{OUT} = 5\text{V}$ $I_O = 0.5\text{A}$ $T_J = \text{Over Temp}^3$		0.5		%
I_O Minimum Load Current		$V_{IN} - V_{OUT} = 25\text{V}$ $I_O = 0.5\text{A}$ $T_J = \text{Over Temp}^3$		5	10	mA
V_N RMS Output Noise ⁵		$T_J = 25^\circ\text{C}$		0.003		% V_O
R_A Ripple Rejection Ratio ⁶		$V_{IN} - V_{OUT} = 3\text{V}$ $I_O = 3\text{A}$ $T_J = \text{Over Temp}^3$	60	75		dB

1. Test Conditions unless otherwise stated: $V_{IN} = 1.5 \text{ to } 35\text{V}$, or Maximum Input, whichever is less.
 $I_O = 10\text{mA to } 5\text{A}$.
2. These specifications are only applicable for power dissipations of 45 Watts over a limited range of $V_{IN} - V_{OUT}$.
3. Over Temp. = Over specified Junction Temperature Range (See Absolute Maximum Ratings).
4. Low duty cycle pulse test with Kelvin connections required. Changes in output voltage are covered under the specification for thermal regulation.
5. Bandwidth of 10Hz to 10kHz.
6. 120Hz input ripple, 15V = 64dB min. $C_{OUT} (C_{ADJ}) = 25\mu\text{F}$.

Semelab Plc reserves the right to change test conditions, parameter limits and package dimensions without notice. Information furnished by Semelab is believed to be both accurate and reliable at the time of going to press. However Semelab assumes no responsibility for any errors or omissions discovered in its use. Semelab encourages customers to verify that datasheets are current before placing orders.

Semelab plc. Telephone +44(0)1455 556565. Fax +44(0)1455 552612.

E-mail: sales@semelab.co.uk Website: <http://www.semelab.co.uk>

Document Number 6386

Issue 1

K Package (TO-3)

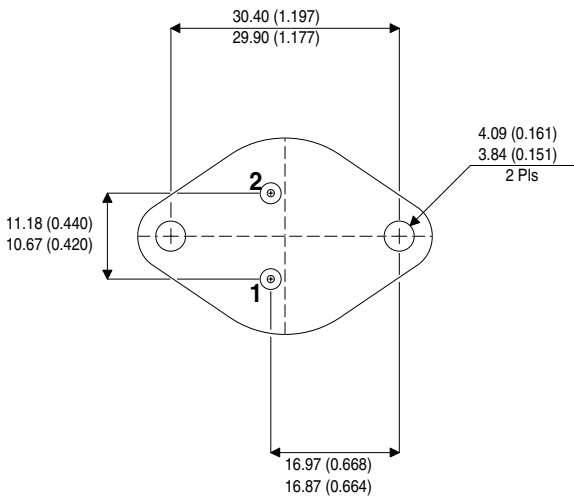
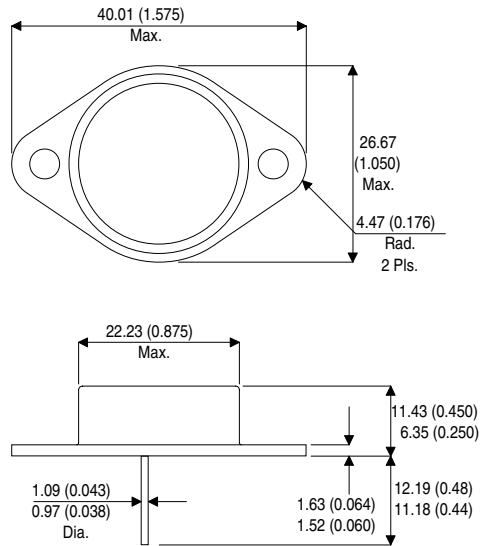

G & IG Packages (TO-257)

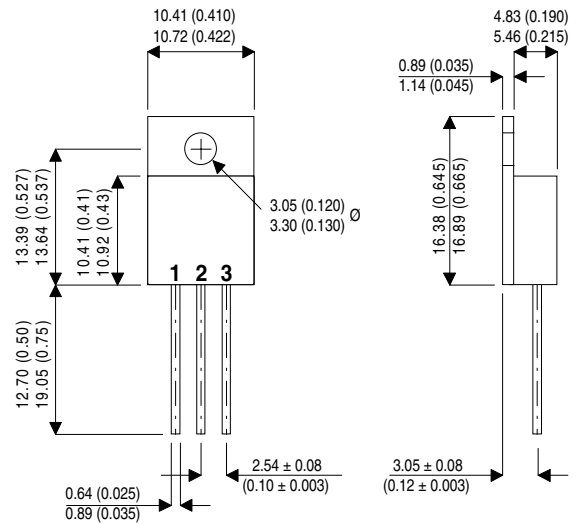

SMD1 Package

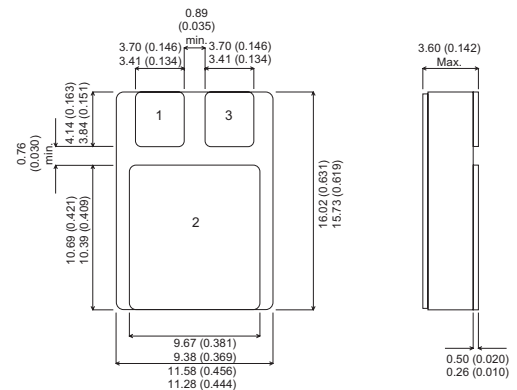

LT1084MK

Pin	Fixed	Adjustable
1	COMMON	ADJUST
2	INPUT	INPUT
Case is OUTPUT		

LT1084MSM

Pin	Fixed	Adjustable
1	COMMON	ADJUST
2	OUTPUT	OUTPUT
3	INPUT	INPUT

LT1084MG

Pin	Fixed	Adjustable
1	COMMON	ADJUST
2	OUTPUT	OUTPUT
3	INPUT	INPUT
Case is OUTPUT		

LT1084MIG

Pin	Fixed	Adjustable
1	COMMON	ADJUST
2	OUTPUT	OUTPUT
3	INPUT	INPUT
Case is ISOLATED		

Semelab Plc reserves the right to change test conditions, parameter limits and package dimensions without notice. Information furnished by Semelab is believed to be both accurate and reliable at the time of going to press. However Semelab assumes no responsibility for any errors or omissions discovered in its use. Semelab encourages customers to verify that datasheets are current before placing orders.

Semelab plc. Telephone +44(0)1455 556565. Fax +44(0)1455 552612.

E-mail: sales@semelab.co.uk Website: <http://www.semelab.co.uk>