

MODULATOR

NIR-MPX and NIR-MPZ Series

1000 nm band Phase Modulators

The ixblue NIR-MP series are phase modulators especially designed to operate in the 1000 nm wavelength band. They are available with various modulation bandwidths, from low frequency to 30 GHz and beyond.

Like all ixblue Near InfraRed (NIR) modulators, the NIR-MP series use a proton exchanged based waveguide process that confers them an unparalleled stability even when operating at high optical power and large range of temperature. The NIR-MP phase modulators come with high PER and Low Insertion Loss options.



FEATURES

- High optical power up to 28 dBm
- High bandwidth version > 30 GHz
- High stability vs optical power
- High stability vs temperature
- Low V_{π}
- Low insertion loss

APPLICATIONS

- Interferometric based sensors
- Spectral broadening
- Frequency shifting
- Laser combining
- Pound-Drever-Hall locking (PDH)
- Optical comb

OPTIONS

- High PER
- Lower Insertion Loss
- Low Residual Amplitude Modulation
- Space grade version (TRL9)

RELATED EQUIPMENTS

- Matched RF amplifiers
- NIR-MX intensity modulators
- Spectral Broadening ModBox-SB
- Coherent Beam Combining ModBox-

NIR-MPX-LN-01 Performance Highlights

Parameter	Min	Typ	Max	Unit
Operating wavelength	950	-	1150	nm
Usable EO bandwidth	-	300	-	MHz
V_{π} RF @50 kHz	-	1.5	2	V

NIR-MPX-LN-02 Performance Highlights

Parameter	Min	Typ	Max	Unit
Operating wavelength	950	-	1150	nm
Usable EO bandwidth	-	5	-	GHz
V_{π} RF @50 kHz	-	1.5	2	V

NIR-MPX-LN-05 Performance Highlights

Parameter	Min	Typ	Max	Unit
Operating wavelength	950	-	1150	nm
Usable EO bandwidth	-	10	-	GHz
V_{π} RF @50 kHz	-	4	-	V

NIR-MPX-LN-10 Performance Highlights

Parameter	Min	Typ	Max	Unit
Operating wavelength	950	-	1150	nm
Usable EO bandwidth	-	16	-	GHz
V_{π} RF @50 kHz	-	5	-	V

NIR-MPZ-LN-20 Performance Highlights

Parameter	Min	Typ	Max	Unit
Operating wavelength	950	-	1150	nm
Usable EO bandwidth	-	30	-	GHz
V_{π} RF @50 kHz	-	5	-	V

MODULATOR | **NIR-MPX-LN SERIES** | 2/7**NIR-MPX-LN-0.1**

300 MHz Phase Modulator

Electrical Characteristics

Parameter	Symbol	Condition	Min	Typ	Max	Unit
Electro-Optical (EO) bandwidth	S_{z1}	-	150	-	-	MHz
Usable EO bandwidth	S_{z1}	-	-	300	-	MHz
V_{π} RF @50 kHz	$V_{\pi_{RF50\text{ kHz}}}$	RF electrodes	-	1.5	2	V
RF input impedance	Z_{in-RF}	-	-	10 000	-	Ω

Optical Characteristics

Parameter	Symbol	Condition	Min	Typ	Max	Unit
Crystal	-	-	Lithium Niobate X-Cut Y-Prop			
Waveguide process	-	-	Proton exchange			
Operating wavelength	λ	-	950	1060	1150	nm
Insertion loss	IL	Without connectors	-	3	4	dB
Low insertion loss option	LIL	Without connectors	-	-	3	dB
Polarization Extinction ratio	PER	Standard, without connectors	20	-	-	dB
		Optional, w/ or w/o connectors	25	30	-	dB
Optical return loss	ORL	-	-40	-45	-	dB

All specifications given at 25 °C, 1060 nm, unless differently specified.

Absolute Maximum Ratings

Stresses in excess of the absolute maximum ratings can cause permanent damage to the device. These are absolute stress ratings only. Functional operation of the device is not implied at these or any other conditions in excess of those given in the operational sections of the data sheet. Exposure to absolute maximum ratings for extended periods can adversely affect device reliability.

Parameter	Symbol	Min	Max	Unit
Modulation voltage range	EV_{in}	-20	+20	V
Optical input power (CW mode)	OP_{in}	-	+25	dBm
Operating temperature	OT	0	+70	°C
Storage temperature	ST	-40	+85	°C

MODULATOR | **NIR-MPX-LN SERIES** | 3/7**NIR-MPX-LN-02**

5 GHz Phase Modulator

Electrical Characteristics

Parameter	Symbol	Condition	Min	Typ	Max	Unit
Electro-optical (EO) bandwidth	S_{21}	-	2	-	-	GHz
Usable EO bandwidth	S_{21}	-	-	5	-	GHz
Ripple S_{21}	ΔS_{21}	-	-	0.5	1	dB
Electrical return loss	S_{11}	-	-	-10	-8	dB
V_{π} RF @50 kHz	$V_{\pi_{RF50\text{ kHz}}}$	-	-	1.5	2	V
RF input impedance	Z_{in-RF}	-	-	50	-	Ω

Optical Characteristics

Parameter	Symbol	Condition	Min	Typ	Max	Unit
Crystal	-	-	Lithium Niobate X-Cut Y-Prop			
Waveguide process	-	-	Proton exchange			
Operating wavelength	λ	-	950	1060	1150	nm
Insertion loss	IL	Without connectors	-	3	4	dB
Low insertion loss option	LIL	Without connectors	-	-	3	dB
Polarization Extinction ratio	PER	Standard, without connectors	20	-	-	dB
		Optional, w/ or w/o connectors	25	30	-	dB
Optical return loss	ORL	-	-40	-45	-	dB

All specifications given at 25 °C, 1060 nm, unless differently

Absolute Maximum Ratings

Stresses in excess of the absolute maximum ratings can cause permanent damage to the device. These are absolute stress ratings only. Functional operation of the device is not implied at these or any other conditions in excess of those given in the operational sections of the data sheet. Exposure to absolute maximum ratings for extended periods can adversely affect device reliability.

Parameter	Symbol	Min	Max	Unit
RF input power (CW mode)	EP_{in}	-	+33	dBm
Optical input power (CW mode)	OP_{in}	-	+25	dBm
Operating temperature	OT	0	+70	°C
Storage temperature	ST	-40	+85	°C

MODULATOR | **NIR-MPX-LN SERIES** | 4/7**NIR-MPX-LN-05**

10 GHz Phase Modulator

Electrical Characteristics

Parameter	Symbol	Condition	Min	Typ	Max	Unit
Electro-optical (EO) bandwidth	S_{21}	-	5	-	-	GHz
Usable EO bandwidth	S_{21}	-	-	10	-	GHz
Ripple S_{21}	ΔS_{21}	-	-	0.5	1	dB
Electrical return loss	S_{11}	-	-	-12	-10	dB
V_{π} RF @50 kHz	$V_{\pi_{RF50\text{ kHz}}}$	-	-	4	5	V
RF input impedance	Z_{in-RF}	-	-	50	-	Ω

Optical Characteristics

Parameter	Symbol	Condition	Min	Typ	Max	Unit
Crystal	-	-	Lithium Niobate X-Cut Y-Prop			
Waveguide process	-	-	Proton exchange			
Operating wavelength	λ	-	950	1060	1150	nm
Insertion loss	IL	Without connectors	-	3	4	dB
Low insertion loss option	LIL	Without connectors	-	-	3	dB
Polarization Extinction ratio	PER	Standard, without connectors	20	-	-	dB
		Optional, w/ or w/o connectors	25	30	-	dB
Optical return loss	ORL	-	-40	-45	-	dB

All specifications given at 25 °C, 1060 nm, unless differently

Absolute Maximum Ratings

Stresses in excess of the absolute maximum ratings can cause permanent damage to the device. These are absolute stress ratings only. Functional operation of the device is not implied at these or any other conditions in excess of those given in the operational sections of the data sheet. Exposure to absolute maximum ratings for extended periods can adversely affect device reliability.

Parameter	Symbol	Min	Max	Unit
RF input power (CW mode)	EP_{in}	-	+33	dBm
Optical input power (CW mode)	OP_{in}	-	+25	dBm
Operating temperature	OT	0	+70	°C
Storage temperature	ST	-40	+85	°C

MODULATOR | **NIR-MPX-LN SERIES** | 5/7**NIR-MPX-LN-10**

18 GHz Phase Modulator

Electrical Characteristics

Parameter	Symbol	Condition	Min	Typ	Max	Unit
Electro-optical (EO) bandwidth	S_{21}	-	10	12	-	GHz
Usable EO bandwidth	S_{21}	-	16	18	-	GHz
Ripple S_{21}	ΔS_{21}	-	-	0.5	1	dB
Electrical return loss	S_{11}	-	-	-12	-10	dB
V_{π} RF @50 kHz	$V_{\pi \text{ RF50 kHz}}$	-	-	5	6	V
RF input impedance	Z_{in-RF}	-	-	50	-	Ω

Optical Characteristics

Parameter	Symbol	Condition	Min	Typ	Max	Unit
Crystal	-	-	Lithium Niobate X-Cut Y-Prop			
Waveguide process	-	-	Proton exchange			
Operating wavelength	λ	-	950	1060	1150	nm
Insertion loss	IL	Without connectors	-	3	4	dB
Low insertion loss option	LIL	Without connectors	-	-	3	dB
Polarization Extinction ratio	PER	Standard, without connectors	20	-	-	dB
		Optional, w/ or w/o connectors	25	30	-	dB
Optical return loss	ORL	-	-40	-45	-	dB

All specifications given at 25 °C, 1060 nm, unless differently

Absolute Maximum Ratings

Stresses in excess of the absolute maximum ratings can cause permanent damage to the device. These are absolute stress ratings only. Functional operation of the device is not implied at these or any other conditions in excess of those given in the operational sections of the data sheet. Exposure to absolute maximum ratings for extended periods can adversely affect device reliability.

Parameter	Symbol	Min	Max	Unit
RF input power (CW mode)	EP_{in}	-	+33	dBm
Optical input power (CW mode)	OP_{in}	-	+25	dBm
Operating temperature	OT	0	+70	°C
Storage temperature	ST	-40	+85	°C

MODULATOR | **NIR-MPX-LN SERIES** | 6/7**NIR-MPZ-LN-20**

30 GHz Phase Modulator

Electrical Characteristics

Parameter	Symbol	Condition	Min	Typ	Max	Unit
Electro-optical (EO) bandwidth	S_{21}	-	-	16	-	GHz
Usable EO bandwidth	S_{21}	-	-	30	-	GHz
Ripple S_{21}	ΔS_{21}	-	-	0.5	1	dB
Electrical return loss	S_{11}	-	-	-13	-	dB
V_{π} RF @50 kHz	$V_{\pi_{RF50\text{ kHz}}}$	-	-	3.5	-	V
V_{π} RF @20 GHz	$V_{\pi_{RF20\text{ GHz}}}$	-	-	6	-	V
RF input impedance	Z_{in-RF}	-	-	50	-	Ω

Optical Characteristics

Parameter	Symbol	Condition	Min	Typ	Max	Unit
Crystal	-	-	Lithium Niobate Z-Cut Y-Prop			
Waveguide process	-	-	Proton exchange			
Operating wavelength	λ	-	950	1060	1150	nm
Insertion loss	IL	Without connectors	-	3	4	dB
Polarization Extinction ratio	PER	Standard, without connectors	20	-	-	dB
Optical return loss	ORL	-	-40	-45	-	dB

All specifications given at 25 °C, 1060 nm, unless differently

Absolute Maximum Ratings

Stresses in excess of the absolute maximum ratings can cause permanent damage to the device. These are absolute stress ratings only. Functional operation of the device is not implied at these or any other conditions in excess of those given in the operational sections of the data sheet. Exposure to absolute maximum ratings for extended periods can adversely affect device reliability.

Parameter	Symbol	Min	Max	Unit
RF input power (CW mode)	EP_{in}	-	+33	dBm
Optical input power (CW mode)	OP_{in}	-	+28	dBm
Operating temperature	OT	0	+70	°C
Storage temperature	ST	-40	+85	°C

MODULATOR | NIR-MPX-LN SERIES | 7/7

Mechanical Diagram and Pinout

All measurements in mm

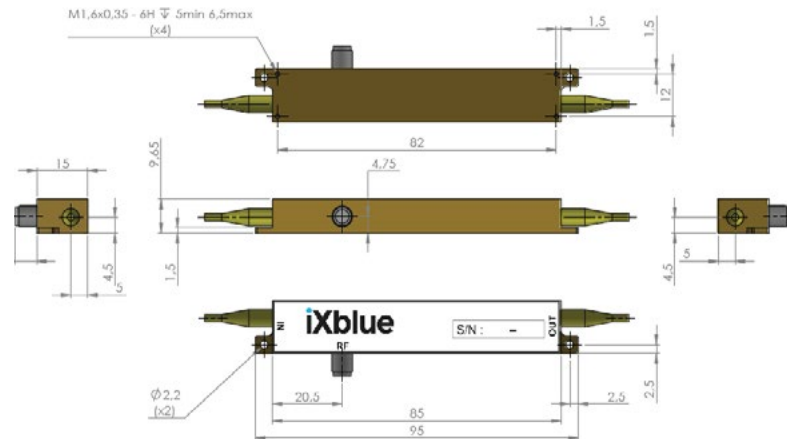

Port	Function	Note
IN	Optical input port	Polarization maintaining fiber Corning PM 98-U25D Length: 1.5 meter, buffer diameter: 900 μm
OUT	Optical output port	Polarization maintaining fiber Corning PM 98-U25D Length: 1.5 meter, buffer diameter: 900 μm
RF	RF input port	Female K

Ordering information

Bandwidth : **X-cut: 01** (150 MHz), **02** (2 GHz),
05 (5 GHz), **10** (10 GHz)
Z-cut: 20 (20 GHz)

Input fiber: P Polarization maintaining

Output fiber: P Polarization maintaining

Input connector: **00** (bare fiber), **FA** (FC/APC)

Output connector: **00** (bare fiber), **FA** (FC/APC)

PER: High Polarization Extinction Ratio option
LL: Low Insertion Loss option

NIR-MPX/MPZ-LN-□-00-□-□-□-□-□

About us

iXblue Photonics produces specialty optical fibers and Bragg gratings based fiber optics components and provides optical modulation solutions based on the company lithium niobate (LiNbO₃) modulators and RF electronic modules. iXblue Photonics serves a wide range of industries: sensing and instruments, defense, telecommunications, space and fiber lasers as well as research laboratories all over the world.

iXblue reserves the right to change, at any time and without notice, the specifications, design, function or form of its products described herein. All statements, specification, technical information related to the products herein are given in good faith and based upon information believed to be reliable and accurate at the moment of printing. However the accuracy and completeness thereof is not guaranteed. No liability is assumed for any inaccuracies and as a result of use of the products. The user must validate all parameters for each application before use and he assumes all risks in connection with

04_2022_ED9 / SP-0005-PR-07 / SP-0058-PR-06 / SP-0003-PR-06 / SP-0004-PR-06 / SP-0101-PR-02 / SP-0242-PR-01