

**DIN 1.0-2.3 RIGHT ANGLE RECEPTACLE**

**R219.660.062**

**4 VOIES**

Series : C1.0-2.3 75

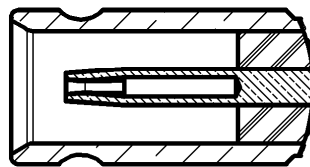
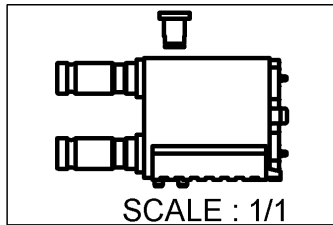
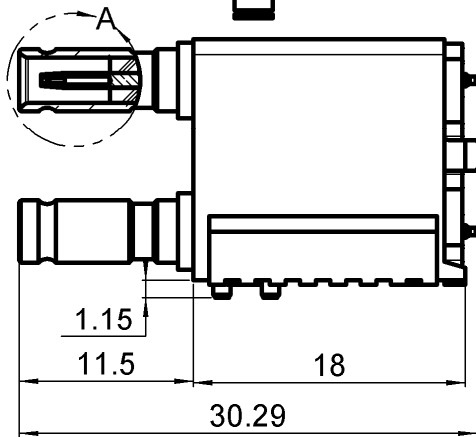
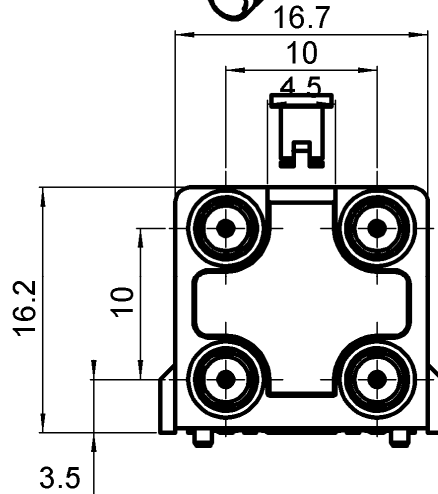
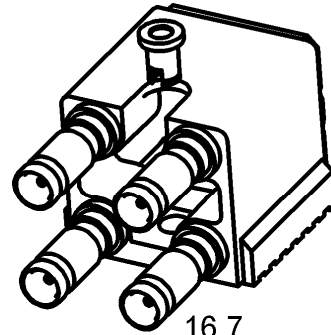
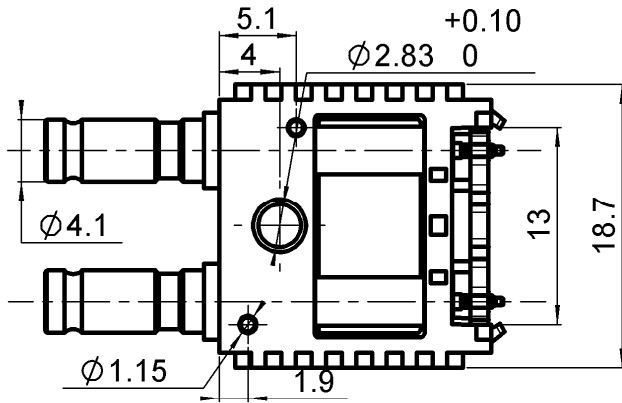

PATENT PENDING

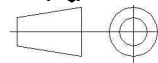
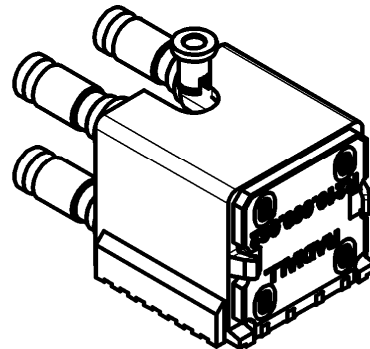

All dimensions are in mm.

COMPONENTS	MATERIALS	PLATING (µm)
BODY	ZAMAK	TIN 3 OVER NICKEL 2 OVER COPPER 8
CENTER CONTACT	BERYLLIUM COPPER	GOLD 1.3 OVER NICKEL2
OUTER CONTACT	BRASS	GOLD 1.3 OVER NICKEL2
INSULATOR	PTFE	
GASKET	-	
OTHERS PARTS	-	
-	-	
-	-	

Issue : 0944 A

In the effort to improve our products, we reserve the right to make changes judged to be necessary.



**DIN 1.0-2.3 RIGHT ANGLE RECEPTACLE**

**R219.660.062**

**4 VOIES**

Series : **C1.0-2.3 75**

**PACKAGING**

**SPECIFICATION**

Standard	Unit	Other
<b>100</b>	<b>'W' option</b>	<b>Contact us</b>

**ELECTRICAL CHARACTERISTICS**

**ENVIRONMENTAL**

Impedance **75**  $\Omega$   
 Frequency **0-0.5** GHz  
 VSWR **1.22 + 0,0000** x F(GHz) Maxi  
 Insertion loss **NA**  $\sqrt{F(GHz)}$  dB Maxi  
 RF leakage - ( **NA** - F(GHz)) dB Maxi  
 Voltage rating **200** Veff Maxi  
 Dielectric withstanding voltage **750** Veff mini  
 Insulation resistance **1000** M $\Omega$  mini

Operating temperature **-40/+85** ° C  
 Hermetic seal **NA** Atm.cm3/s  
 Panel leakage **NA**

**OTHER CHARACTERISTICS**

Assembly instruction

Others :  
 Outer contact/body axial retention: >150

**MECHANICAL CHARACTERISTICS**

Center contact retention  
 Axial force – Mating end **20** N mini  
 Axial force – Opposite end **20** N mini  
 Torque **NA** N.cm mini

Recommended torque  
 Mating **NA** N.cm  
 Panel nut **NA** N.cm

Mating life **250** Cycles mini  
 Weight **17,8630** g

Issue : 0944 A

In the effort to improve our products, we reserve the right to make changes judged to be necessary.



**DIN 1.0-2.3 RIGHT ANGLE RECEPTACLE**

**R219.660.062**

**4 VOIES**

Series : C1.0-2.3 75

**SOLDER PROCEDURE**

1. Deposition of solder paste 'Sn Ag4 Cu0.5' on mounting zone by screen printing application. We recommend a low residue flux.  
We advise a thickness of 200 microns ( 7.800 microinch ). Verify that the edges of the zone are clean.
2. Placement of the receptacle on the mounting zone with an automatic machine of 'pick and place' type.  
Video camera is recommended for the positioning of the component. Adhesive agents must not be used on the receptacle.
3. Soldering by infra-red reflow.  
Below, please find the typical profile to use.
4. Cleaning of printed circuit boards.
5. Checking of solder joints and position of the component by visual inspection.

**TEMPERATURE PROFILE**

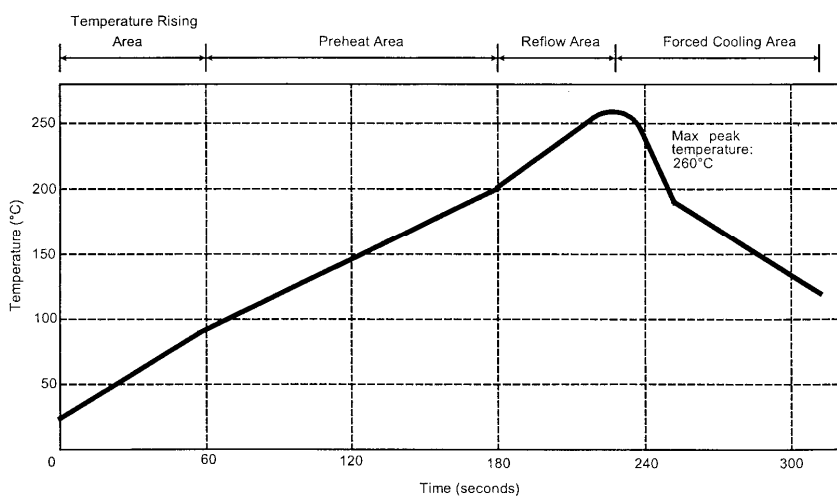

Parameter	Value	Unit
Temperature rising Area	1 - 4	°C/sec
Max Peak Temperature	260	°C
Max dwell time @260°C	10	sec
Min dwell time @235°C	20	sec
Max dwell time @235°C	60	sec
Temperature drop in cooling Area	-1 to -4	°C/sec
Max dwell time above 100°C	420	sec

Issue : 0944 A

In the effort to improve our products, we reserve the right to make changes judged to be necessary.



**DIN 1.0-2.3 RIGHT ANGLE RECEPTACLE**

**R219.660.062**

**4 VOIES**

Series : C1.0-2.3 75

**COPLANAR LINE**

``Pattern and signal are on the same side. Thickness of PCB : .062 (1.6 mm)

The PCB material: Fibber glass (ER = 4.8)

The solder resist should be printed except for the land pattern on the PCB

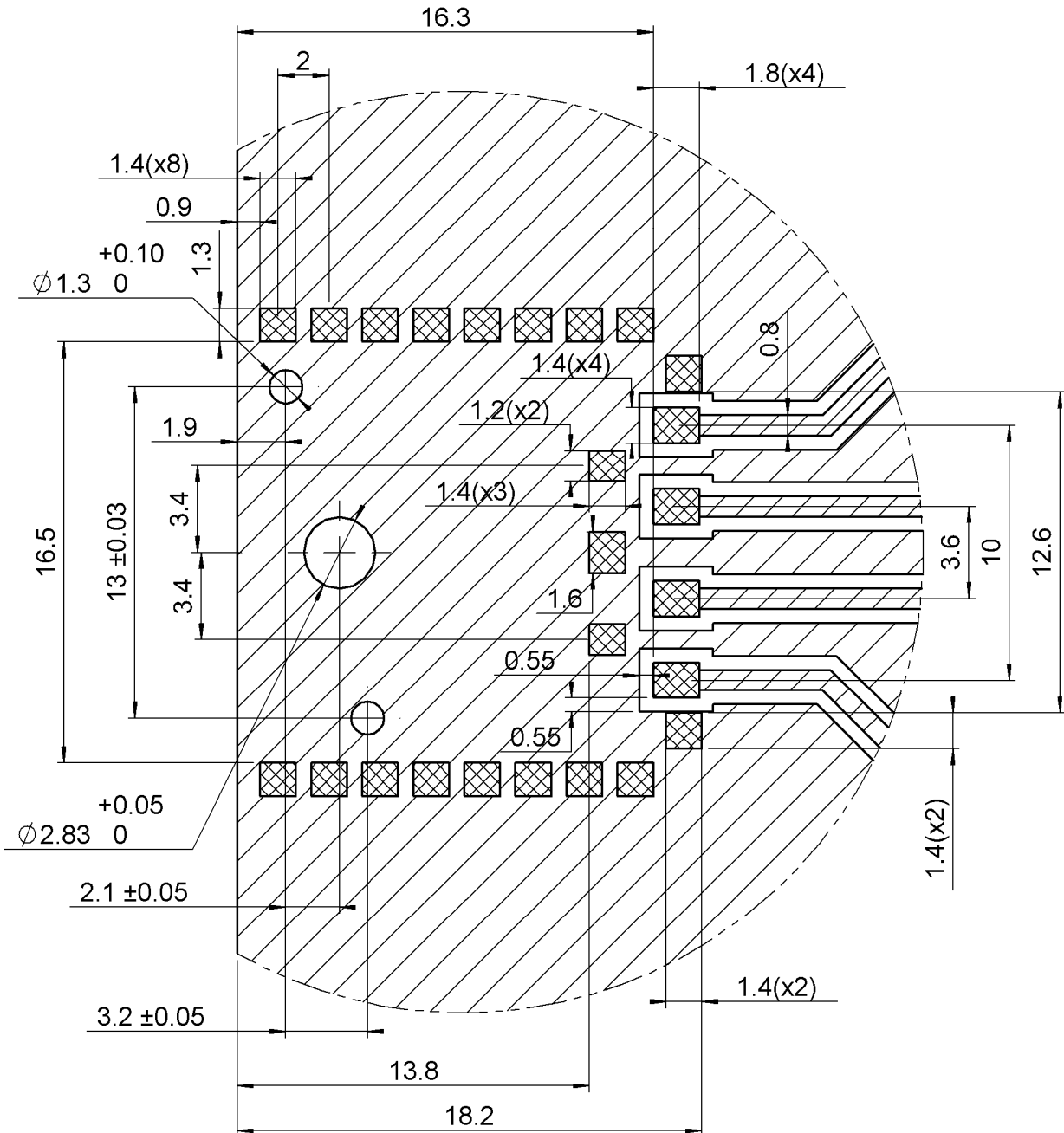

**Pattern**



**Land for solder**

Issue : 0944 A

In the effort to improve our products, we reserve the right to make changes judged to be necessary.



**DIN 1.0-2.3 RIGHT ANGLE RECEPTACLE**

**R219.660.062**

**4 VOIES**

Series : C1.0-2.3 75

**SHADOW OF RECEPTACLE FOR VIDEO CAMERA**

**ASPIRATION NOZZLE :Use L TYPE Nozzle Rubber pad system**

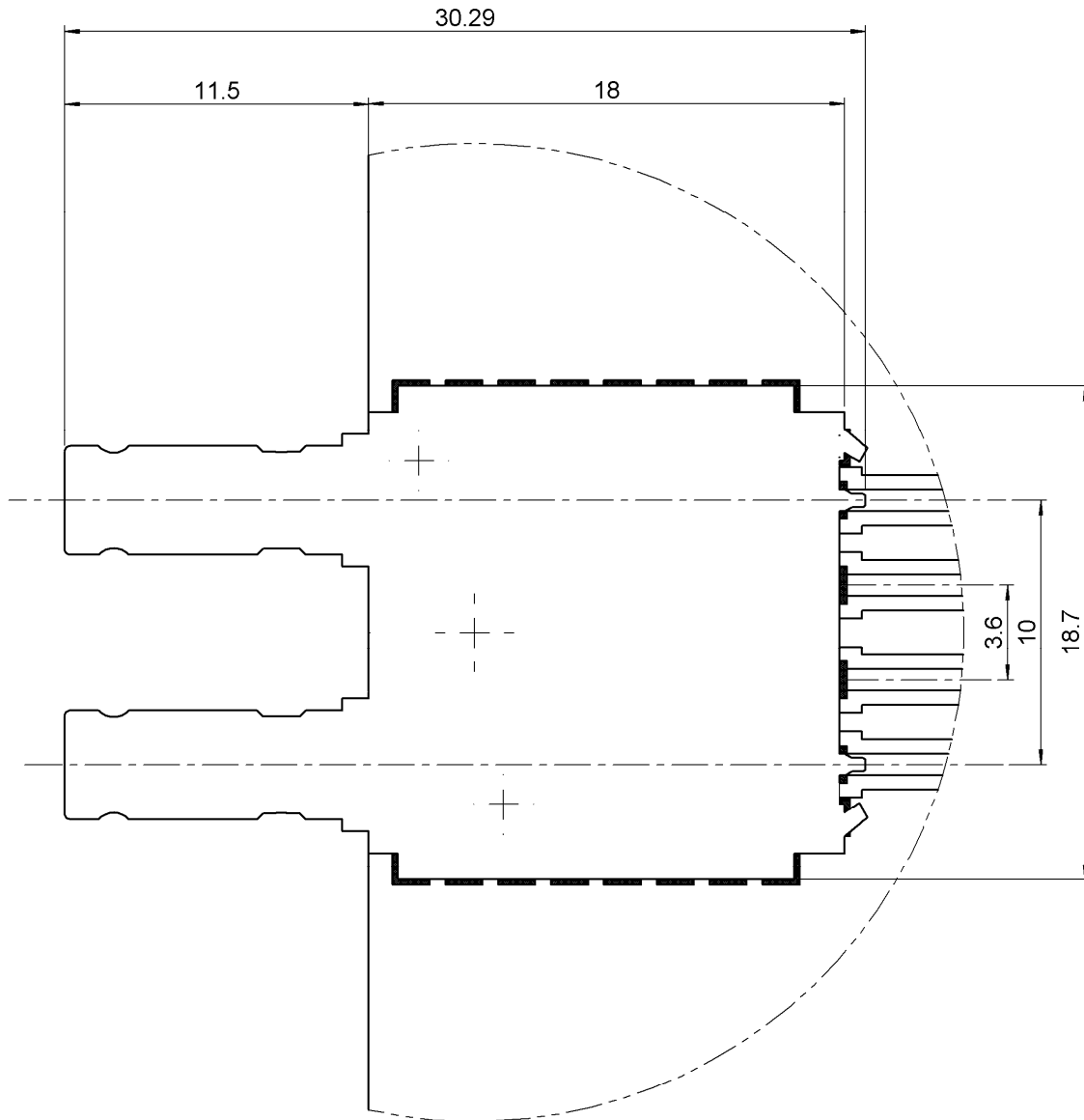

Issue : 0944 A

In the effort to improve our products, we reserve the right to make changes judged to be necessary.



**DIN 1.0-2.3 RIGHT ANGLE RECEPTACLE**

**R219.660.062**

**4 VOIES**

Series : C1.0-2.3 75

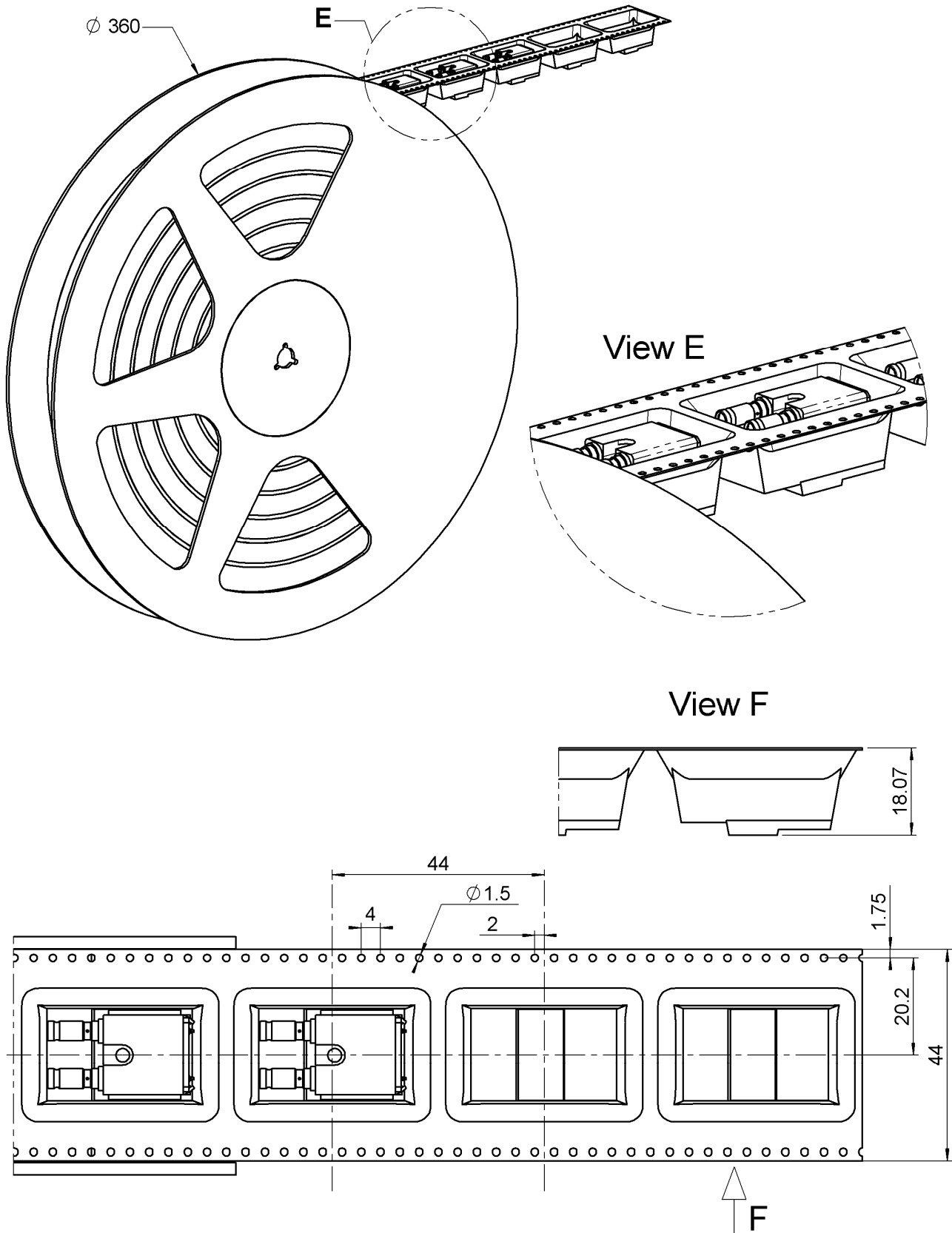

Issue : 0944 A

In the effort to improve our products, we reserve the right to make changes judged to be necessary.



**DIN 1.0-2.3 RIGHT ANGLE RECEPTACLE**

**R219.660.062**

**4 VOIES**

Series : C1.0-2.3 75

**BOARD LOCK MECHANISM**

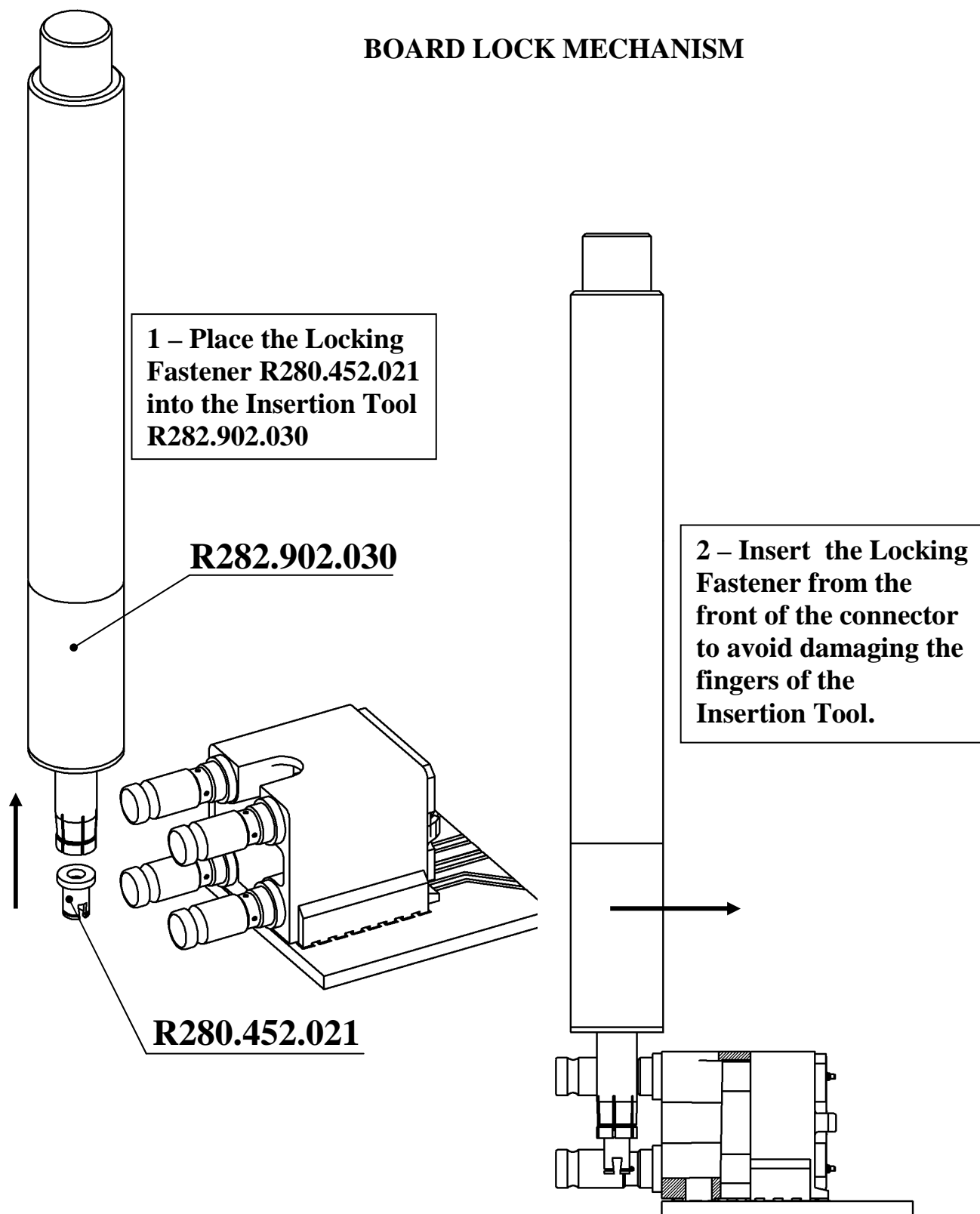

Issue : 0944 A

In the effort to improve our products, we reserve the right to make changes judged to be necessary.



**DIN 1.0-2.3 RIGHT ANGLE RECEPTACLE**

**R219.660.062**

**4 VOIES**

Series : C1.0-2.3 75

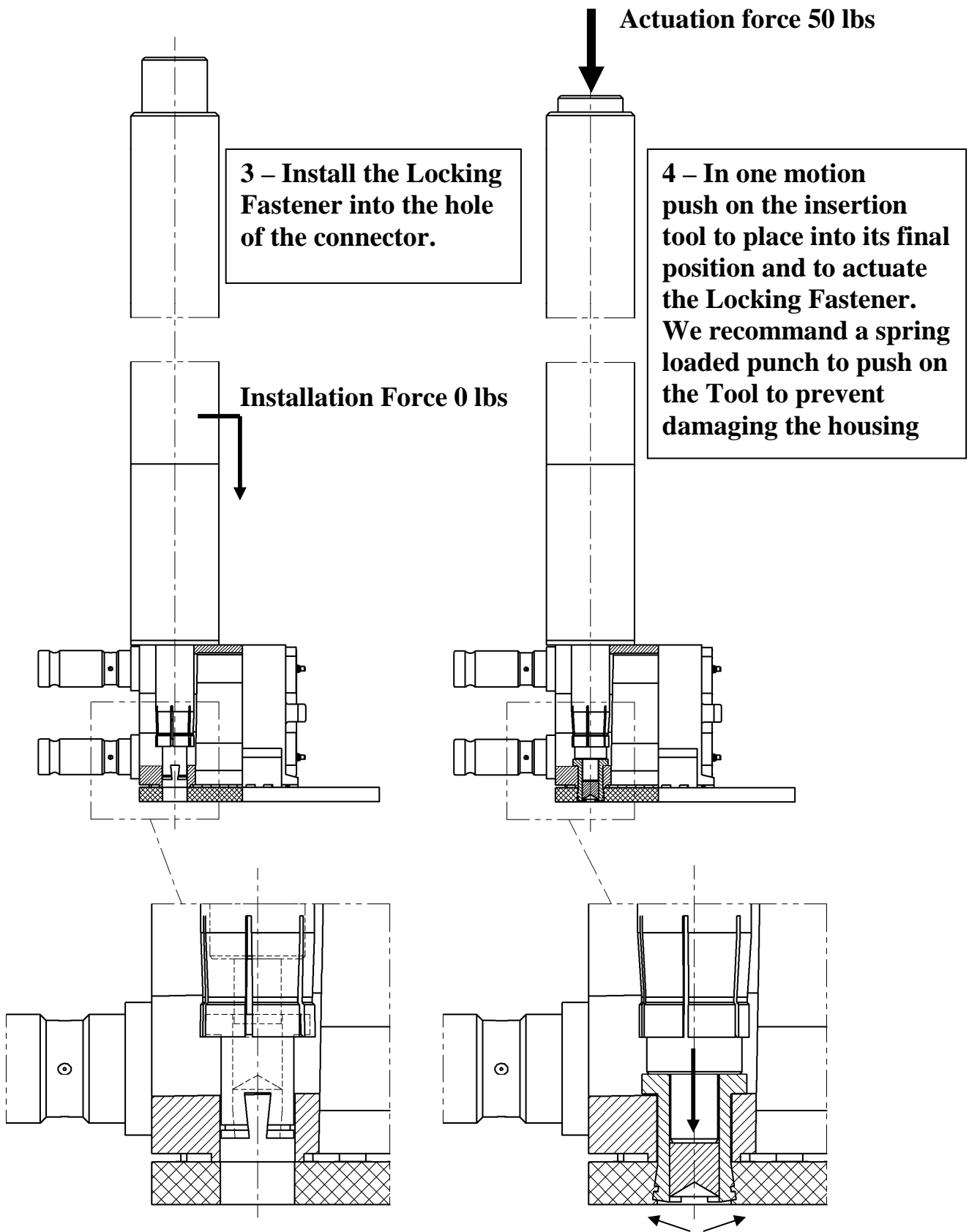

Issue : 0944 A

In the effort to improve our products, we reserve the right to make changes judged to be necessary.

