

Supersedes January 1997 version, DS4681 - 4.0

DS4681 - 4.1 March 1998

### APPLICATIONS

- UPS.
- Induction Heating.
- A.C. Motor Drives.
- Switch Mode Power Supplies.
- Choppers.

### KEY PARAMETERS

$V_{DRM}$	<b>1400V</b>
$I_{T(RMS)}$	<b>400A</b>
$I_{TSM}$	<b>4000A</b>
$dV/dt$	<b>1000V/μs</b>
$dI/dt$	<b>1000A/μs</b>
$t_q$	<b>10.0μs</b>

### FEATURES

- Low Loss Asymmetrical Diffusion Structure.
- Fully Characterised For Operation up to 20kHz..
- High  $dI/dt$  and  $dV/dt$  ratings

### VOLTAGE RATINGS

Type Number	Repetitive Peak Off-state Voltage $V_{DRM}$ V	Repetitive Peak Reverse Voltage $V_{RRM}$ V
TA449 14 W	1400	10
TA449 12 W	1200	10
TA449 10 W	1000	10

Lower voltage grades available.

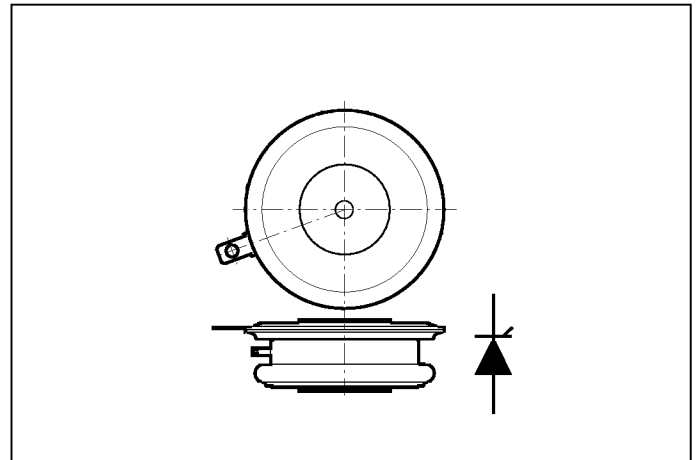

Outline type code: MU86. See package outlines for further information.

### CURRENT AND SURGE RATINGS

Symbol	Parameter	Conditions	Max.	Units
<b>Double Side Cooled</b>				
$I_{T(AV)}$	Mean on-state current	Half sine wave, duty cycle 50%, $T_{case} = 80^{\circ}C, T_j = 125^{\circ}C.$	255	A
$I_{T(RMS)}$	RMS value		400	A
$I_{TSM}$	Surge (non-repetitive) on-state current	$T_j = 125^{\circ}C, t_p = 1ms, V_R = 0$	4000	A
$I^2t$	$I^2t$ for fusing	$t_p \geq 10ms$	$80 \times 10^3$	A <sup>2</sup> s

## THERMAL AND MECHANICAL DATA

Symbol	Parameter	Conditions		Min.	Max.	Units
$R_{th(j-c)}$	Thermal resistance - junction to case	Double side cooled	dc	-	0.07	°C/W
		Single side cooled	Anode dc	-	0.133	°C/W
			Cathode dc	-	0.154	°C/W
$R_{th(c-h)}$	Thermal resistance - case to heatsink	Clamping force 5.0kN with mounting compound	Double side	-	0.02	°C/W
			Single side	-	0.04	°C/W
$T_{vj}$	Virtual junction temperature	On-state (conducting)		-	135	°C
		Reverse (blocking)		-	125	°C
$T_{stg}$	Storage temperature range			-40	150	°C
-	Clamping force			4.5	5.5	kN

## DYNAMIC CHARACTERISTICS

Symbol	Parameter	Conditions		Typ.	Max.	Units
$V_{TM}$	Maximum on-state voltage	At 600A peak, $T_{case} = 125^{\circ}C$		-	2.9	V
$I_{RRM}$	Peak reverse current	At $V_{RRM}$ , $T_{case} = 125^{\circ}C$		-	40	mA
$I_{DRM}$	Off-state current	At $V_{DRM}$ , $T_{case} = 125^{\circ}C$		-	1	mA
dV/dt	Maximum linear rate of rise of off-state voltage	To 60% $V_{DRM}$ , $T_j = 125^{\circ}C$ , Gate open circuit		-	1000	V/ $\mu$ s
dI/dt	Rate of rise of on-state current	Gate source 20V, 20 $\Omega$ $t_r \leq 5\mu$ s.	Non-repetitive	-	1000	A/ $\mu$ s
			Repetitive	-	500	A/ $\mu$ s
$I_H$	Holding current	$T_j = 25^{\circ}C$ , $I_{TM} = 1A$ , $V_D = 12V$		-	80	mA
$I_L$	Latching current	$T_j = 25^{\circ}C$ , $I_G = 0.5A$ , $V_D = 12V$		-	300	mA
$t_q$	Max. turn-off time	VR = DF451 voltage drop, $T_j = 125^{\circ}C$ , $I_{TM} = 200A$ , dV/dt = 400V/ $\mu$ s (linear to 60% $V_{DRM}$ ), tdI <sub>R</sub> /dt = 30A/ $\mu$ s Gate open.		-	10	$\mu$ s
$t_{gt}$	Typ. turn-on time (total)	$T_j = 25^{\circ}C$ , $I_T = 50A$ , $V_D = 300V$ , $I_G = 1A$ , dI/dt = 50A/ $\mu$ s, dI <sub>G</sub> /dt = 1A/ $\mu$ s		3	-	$\mu$ s
$t_{gd}$	Typ. delay time			1.5	-	$\mu$ s

## GATE TRIGGER CHARACTERISTICS AND RATINGS

Symbol	Parameter	Conditions	Min.	Max.	Units
$V_{GT}$	Gate trigger voltage	$V_{DWM} = 12V, R_L = 3\Omega, T_{case} = 25^\circ C$	-	5	V
$I_{GT}$	Gate trigger current	$V_{DWM} = 12V, R_L = 3\Omega, T_{case} = 25^\circ C$	-	400	mA
$V_{GD}$	Min. non trigger voltage	-	0.2	-	V
$V_{RGM}$	Peak reverse gate voltage	-	-	5	V
$I_{FGM}$	Peak forward gate current	-	-	4	A
$P_{GM}$	Peak gate power	-	-	16	W
$P_{G(AV)}$	Average gate power	Average time 10ms max	-	3	W

CURVES

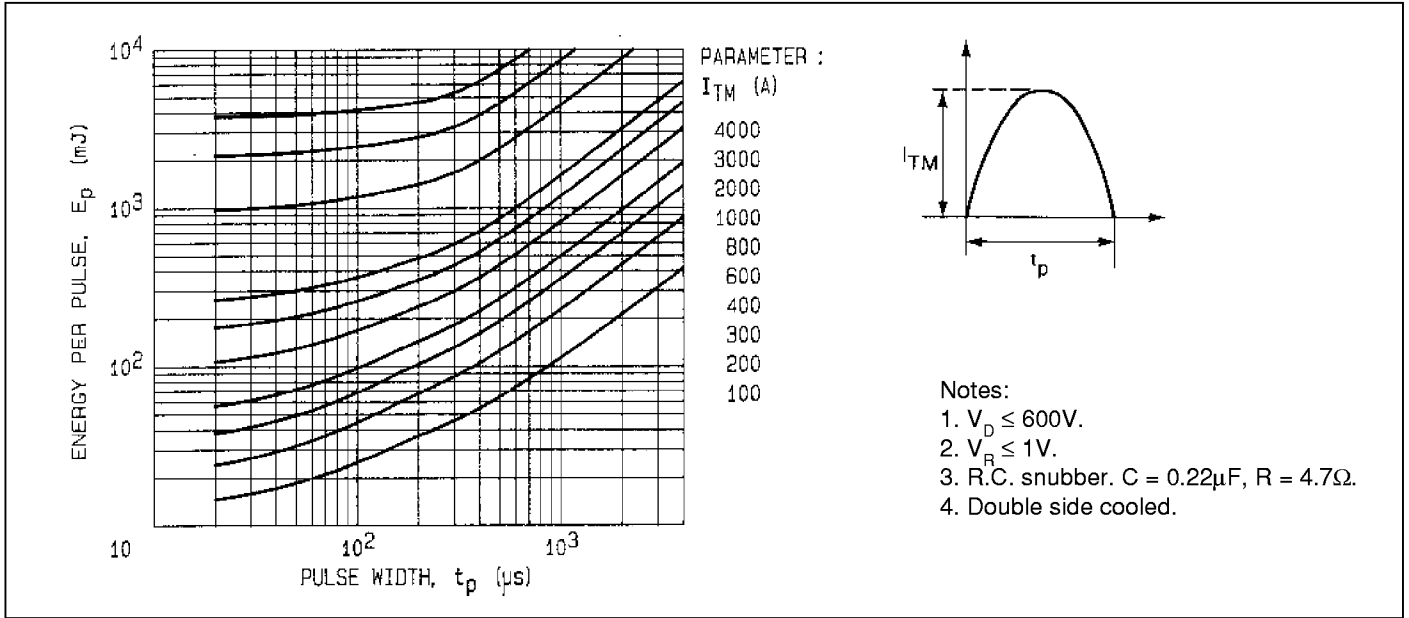

Fig.1 Energy per pulse for sinusoidal pulses.

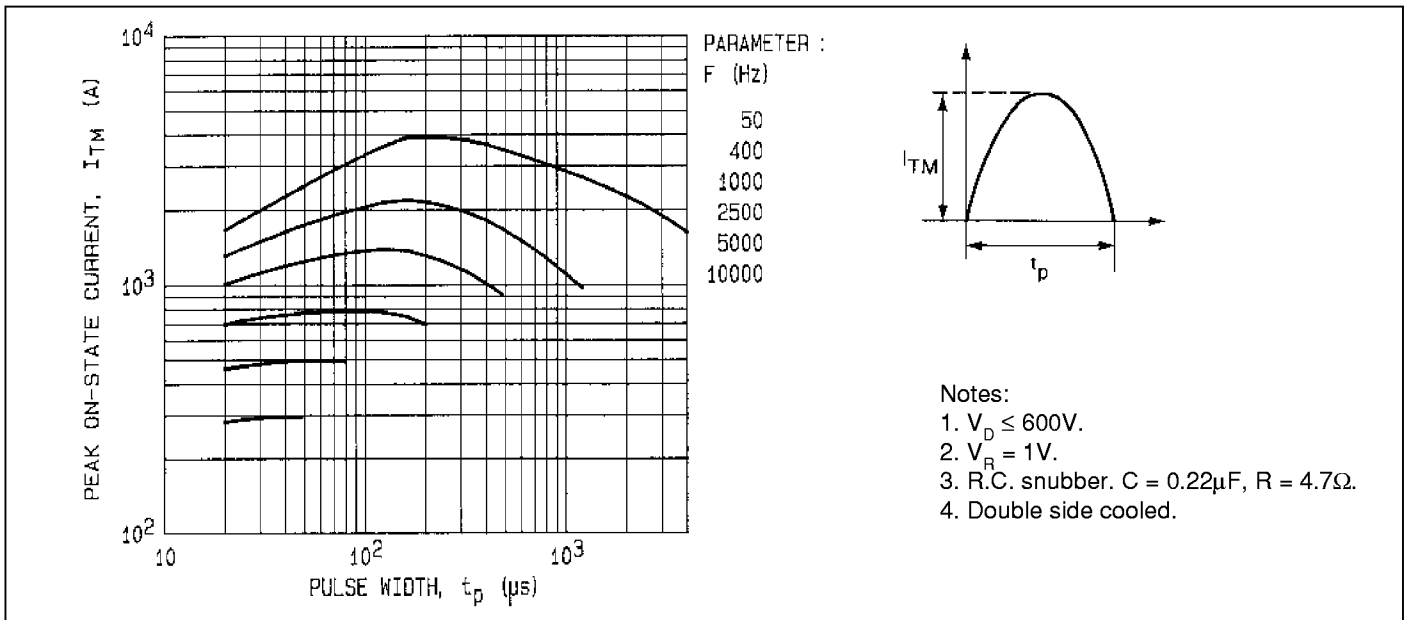

Fig.2 Maximum allowable peak on-state current vs pulse width for  $T_{case} = 65^\circ C$ .

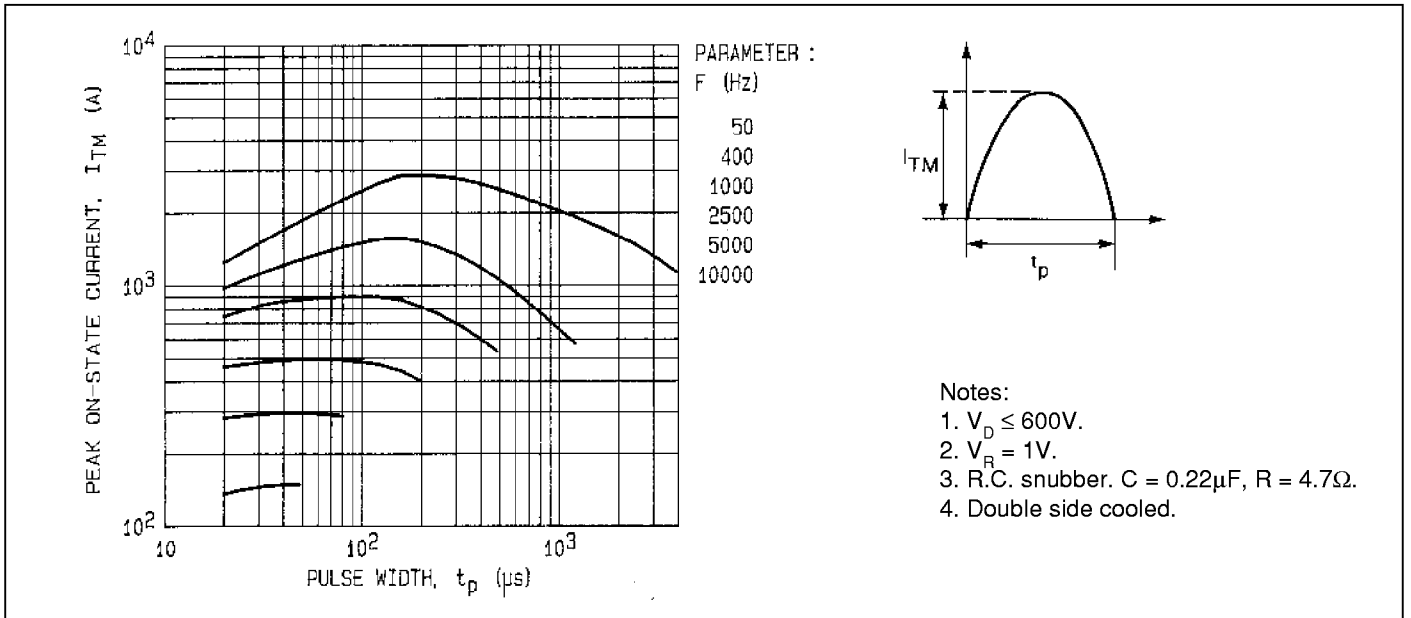

Fig.3 Maximum allowable peak on-state current vs pulse width for  $T_{case} = 90^\circ C$ .

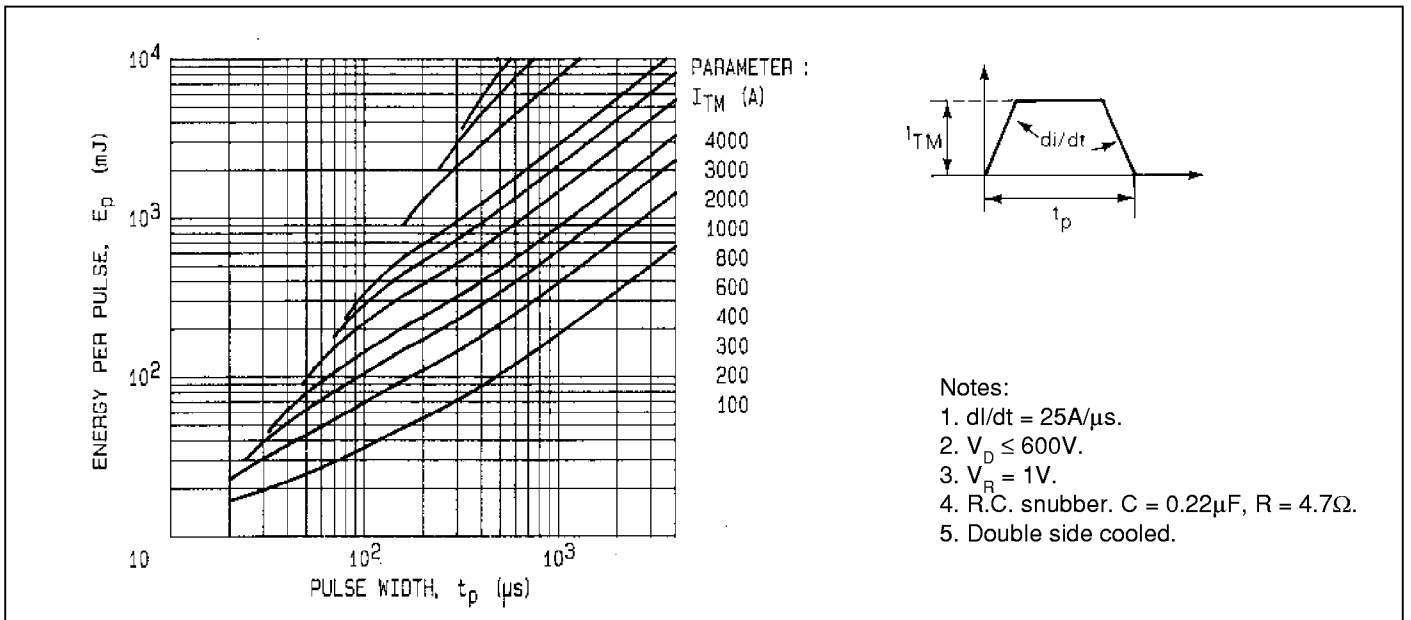

Fig.4 Energy per pulse for trapezoidal pulses

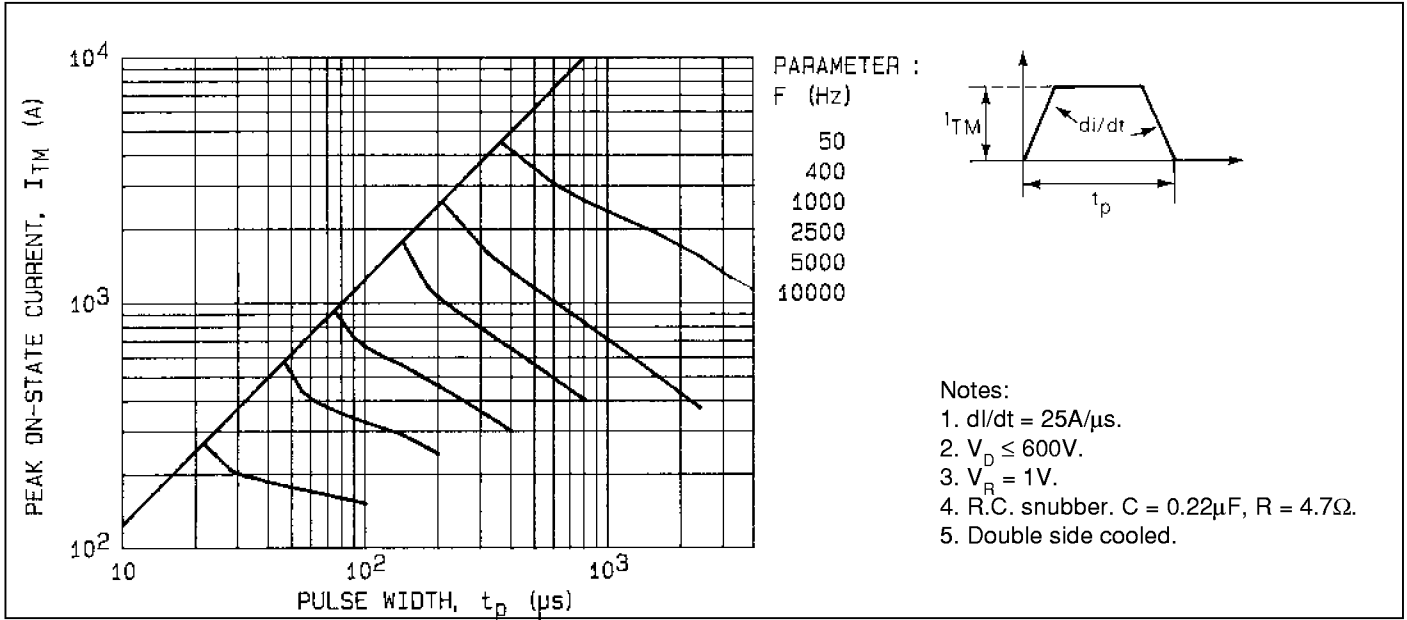

Fig.5 Maximum allowable peak on-state current vs pulse width for  $T_{case} = 65^\circ C$ .

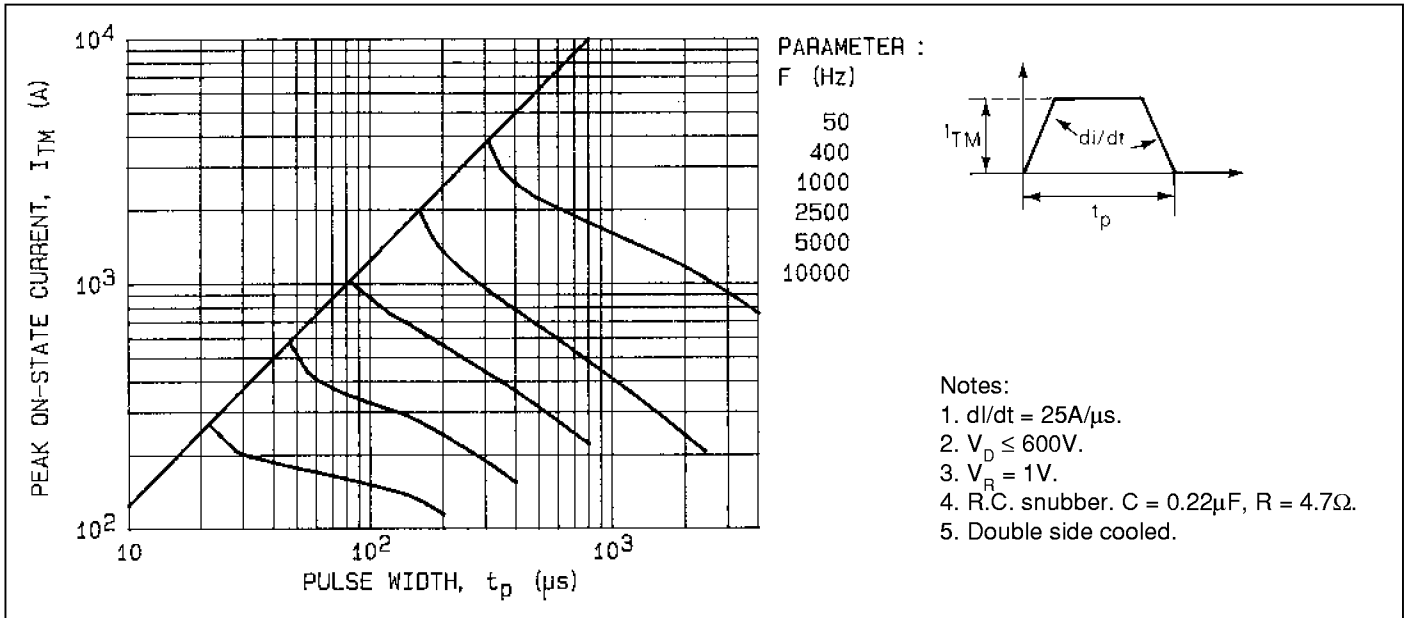

Fig.6 Maximum allowable peak on-state current vs pulse width for  $T_{case} = 90^\circ C$ .

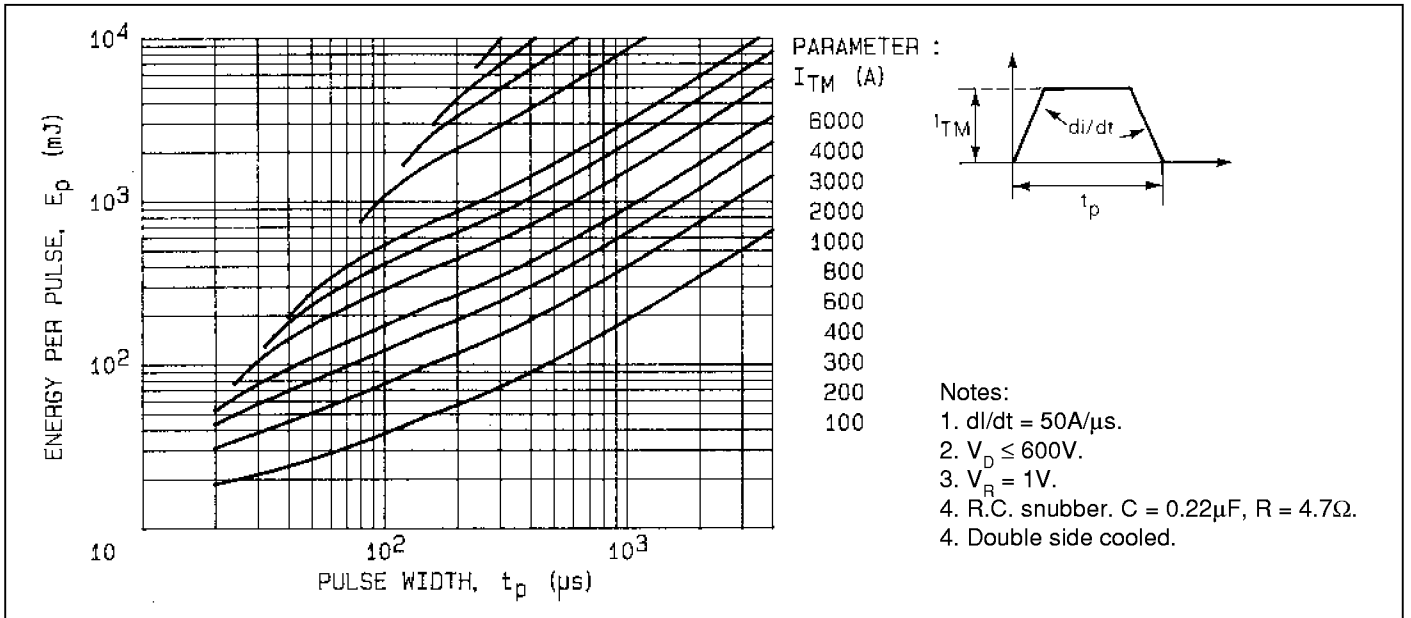

Fig.7 Energy per pulse for trapezoidal pulses.

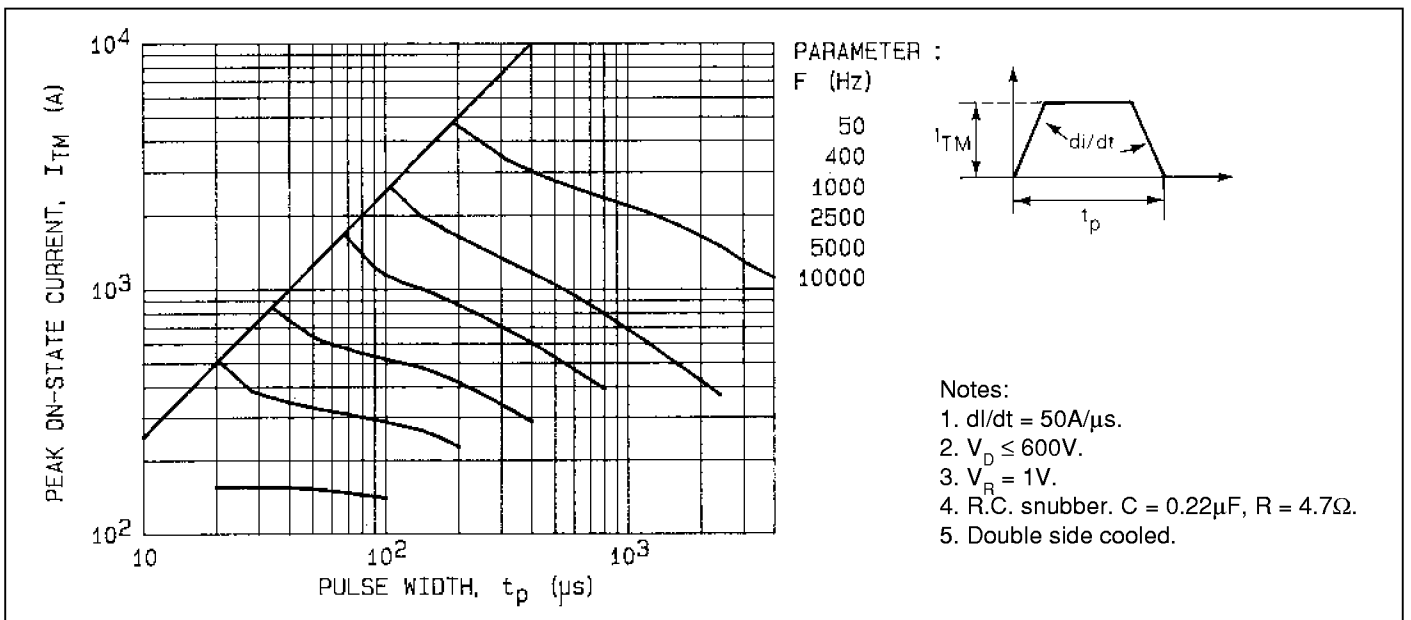

Fig.6 Maximum allowable peak on-state current vs pulse width for  $T_{case} = 90^\circ C$ .

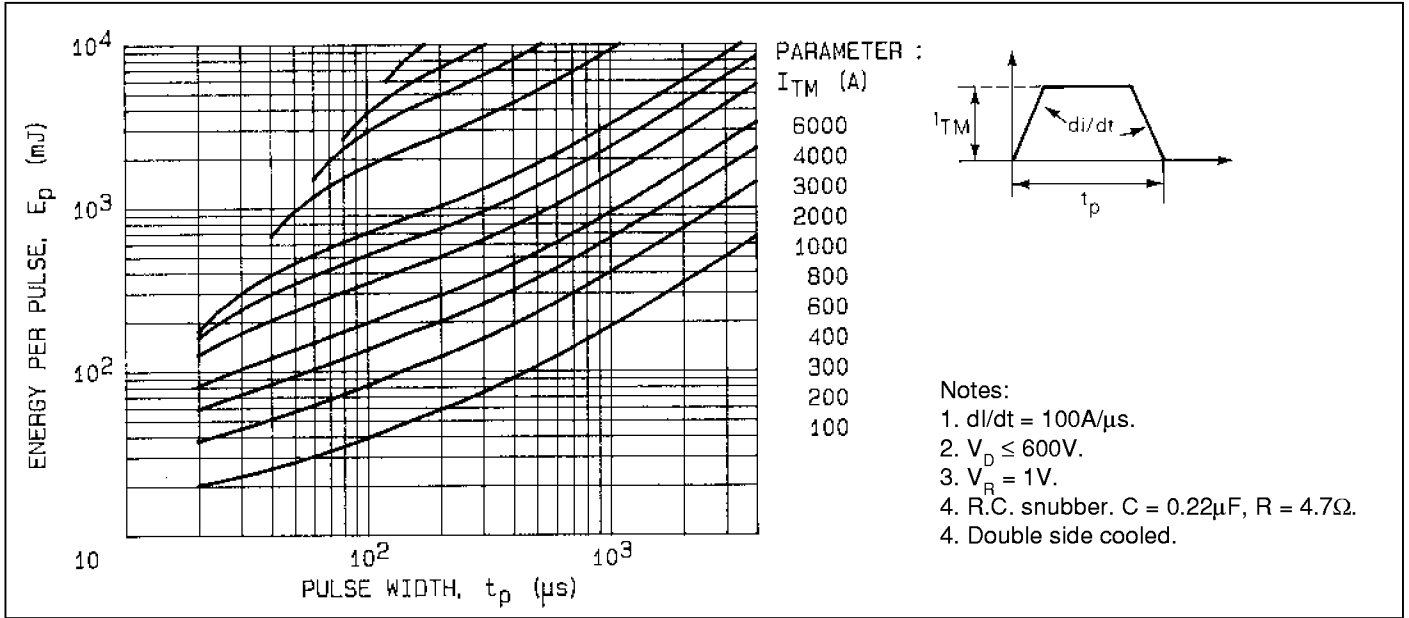

Fig.10 Energy per pulse for trapezoidal pulses.

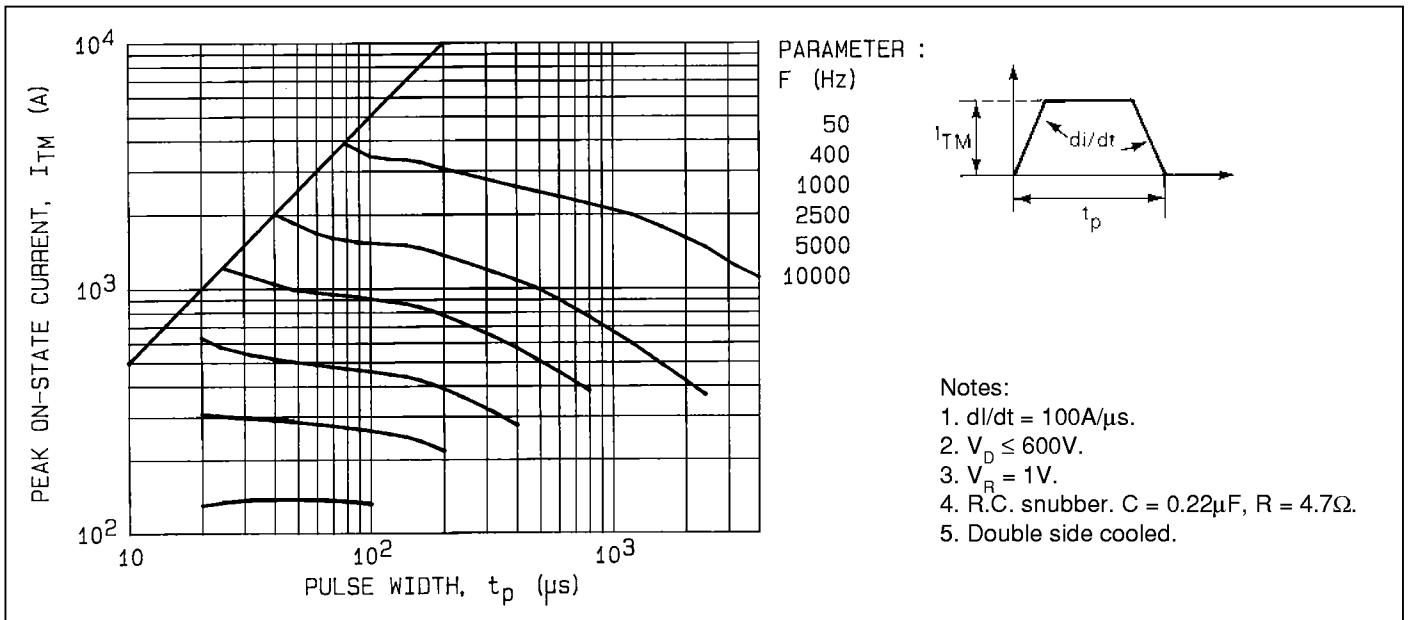

Fig.11 Maximum allowable peak on-state current vs pulse width for  $T_{case} = 65^\circ C$ .

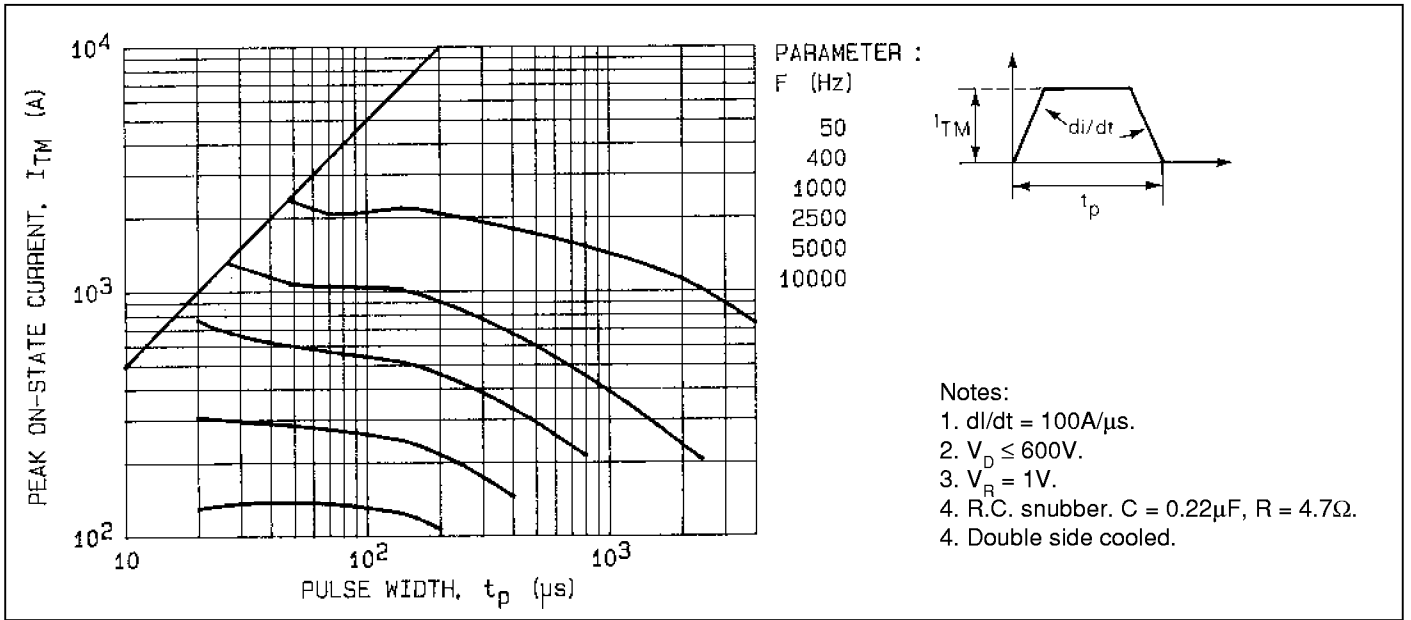

Fig.12 Maximum allowable peak on-state current vs pulse width for  $T_{case} = 90^\circ C$ .

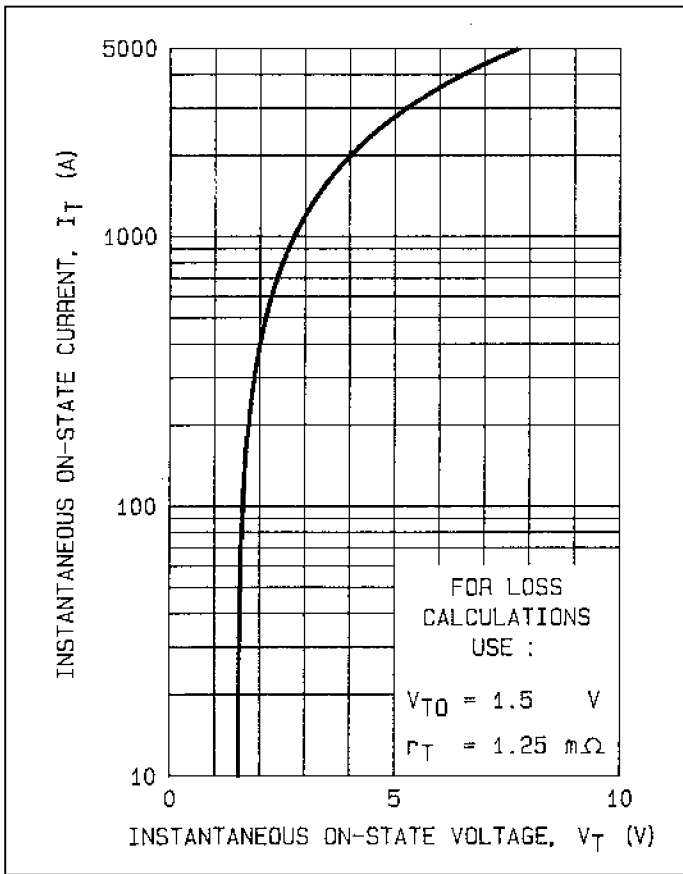

Fig.13 Maximum on-state conduction characteristic ( $T_j = 125^\circ C$ )

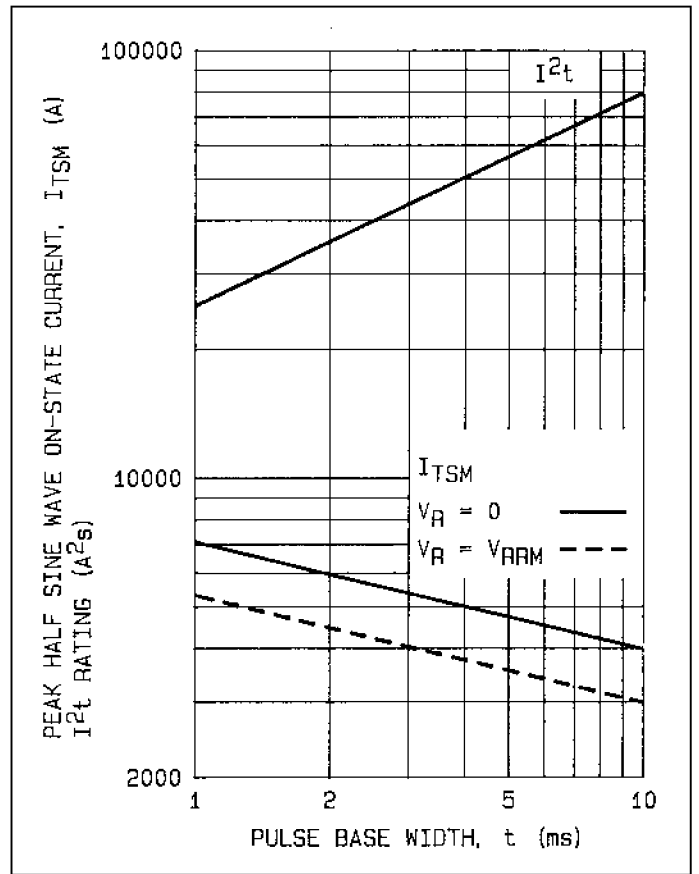

Fig.14 Non-repetitive sub-cycle surge on-state current and  $I^2t$  rating. (Initial  $T_j = 125^\circ C$ )

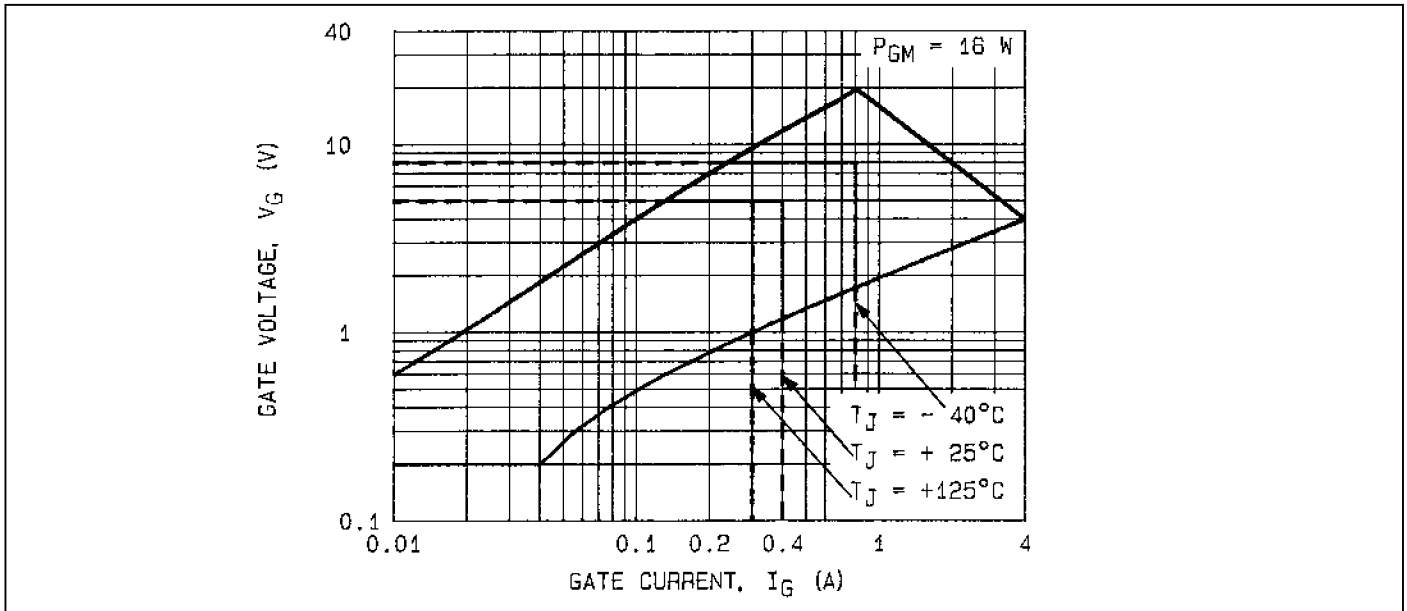

Fig.15 Gate trigger characteristics

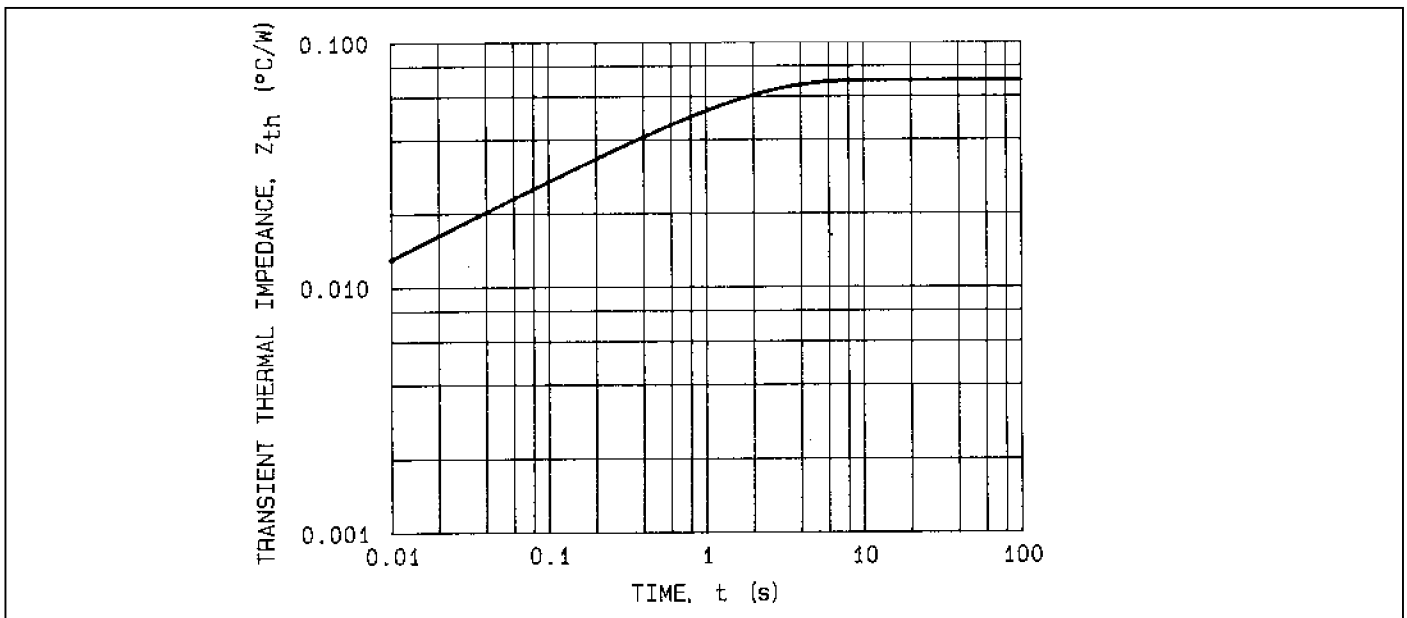
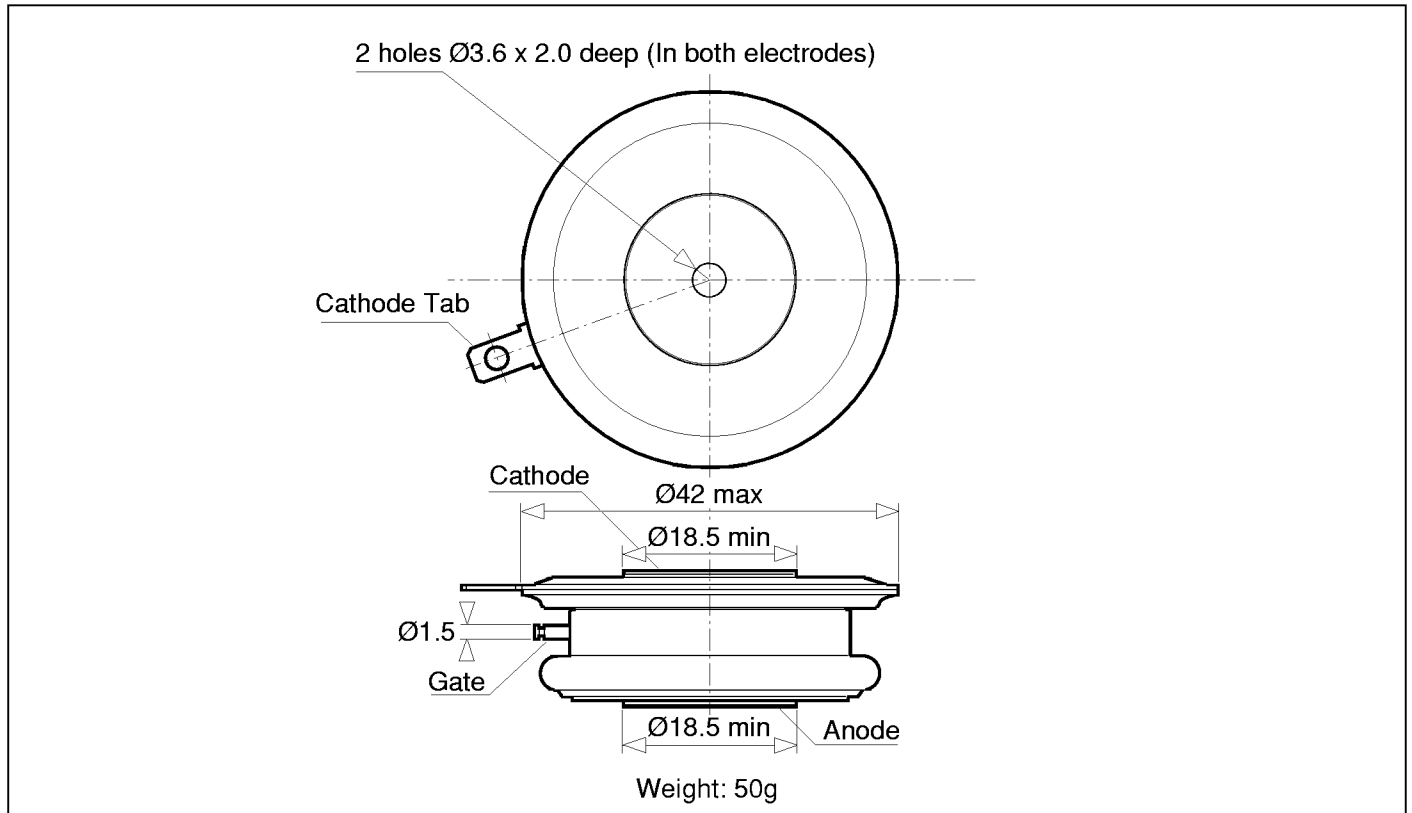

Fig.16 Transient thermal impedance - junction to case (double side cooled)

**PACKAGE DETAILS - MU86**

For further package information, please contact your local Customer Service Centre. All dimensions in mm, unless stated otherwise. DO NOT SCALE.



HEADQUARTERS OPERATIONS  
**MITEL SEMICONDUCTOR**  
 Cheney Manor, Swindon,  
 Wiltshire SN2 2QW, United Kingdom.  
 Tel: (01793) 518000  
 Fax: (01793) 518411

**MITEL SEMICONDUCTOR**  
 1500 Green Hills Road,  
 Scotts Valley, California 95066-4922  
 United States of America.  
 Tel (408) 438 2900  
 Fax: (408) 438 5576/6231

Internet: <http://www.gpsemi.com>

POWER PRODUCT CUSTOMER SERVICE CENTRES

- **FRANCE, BENELUX & SPAIN** Les Ulis Cedex Tel: (1) 69 18 90 00 Fax : (1) 64 46 54 50
- **GERMANY** Munich Tel: (089) 419508-20 Fax : (089) 419508-55
- **NORTH AMERICA** Dedham, USA Tel: (781) 251 0126 Fax: (781) 251 0106
- **UK** Lincoln Tel: (01522) 500500 Fax : (01522) 510550

These are supported by Agents and Distributors in major countries world-wide.

© Mitel Corporation 1998 Publication No. DS4681-4 Issue No. 4.1 March 1998

TECHNICAL DOCUMENTATION – NOT FOR RESALE. PRINTED IN UNITED KINGDOM

This publication is issued to provide information only which (unless agreed by the Company in writing) may not be used, applied or reproduced for any purpose nor form part of any order or contract nor to be regarded as a representation relating to the products or services concerned. No warranty or guarantee express or implied is made regarding the capability, performance or suitability of any product or service. The Company reserves the right to alter without prior notice the specification, design or price of any product or service. Information concerning possible methods of use is provided as a guide only and does not constitute any guarantee that such methods of use will be satisfactory in a specific piece of equipment. It is the user's responsibility to fully determine the performance and suitability of any equipment using such information and to ensure that any publication or data used is up to date and has not been superseded. These products are not suitable for use in any medical products whose failure to perform may result in significant injury or death to the user. All products and materials are sold and services provided subject to the Company's conditions of sale, which are available on request.

All brand names and product names used in this publication are trademarks, registered trademarks or trade names of their respective owners.