



ZT307xE
Low Power 3V 250Kbps/500Kbps/16Mbps RS485 Transceivers
Datasheet

Revision 2.10
June 22th, 2020



IMPORTANT NOTICE

Copyright © 2012-2020 ASIX Electronics Corporation. All rights reserved.

DISCLAIMER

No part of this document may be reproduced or transmitted in any form or by any means, electronic or mechanical, including photocopying and recording, for any purpose, without the express written permission of ASIX. ASIX may make changes to the product specifications and descriptions in this document at any time, without notice.

ASIX provides this document “as is” without warranty of any kind, either expressed or implied, including without limitation warranties of merchantability, fitness for a particular purpose, and non-infringement.

Designers must not rely on the absence or characteristics of any features or registers marked “reserved”, “undefined” or “NC”. ASIX reserves these for future definition and shall have no responsibility whatsoever for conflicts or incompatibilities arising from future changes to them. Always contact ASIX to get the latest document before starting a design of ASIX products.

TRADEMARKS

ASIX, the ASIX logo are registered trademarks of ASIX Electronics Corporation. All other trademarks are the property of their respective owners.

Features

- Meets or exceeds the requirements of ANSI Standard TIA/EIA-485-A and ISO 8482:1987(E) specifications for V_{CC} at $+3.3V \pm 10\%$
- Low quiescent current – 0.5mA typ., 1.5mA max.
- Low shutdown current (where applicable) - 0.05 μ A typical, 10 μ A max.
- Guaranteed standard data rate 250Kbps, 500Kbps, or 16Mbps
- True Fail-Safe (Open and Short) Receiver
- -7V to +12V common-mode input voltage range
- Half-Duplex or Full-Duplex configuration
- Allows up to 1/8 unit load (256 devices) on the same common bus
- Controlled driver output slew rate and receiver input filtering
- Active-high driver enable and active-low receiver enable
- ESD Protection on bus terminals
 $\pm 15KV$ Human Body Model (HBM)
- Drop-in Replacements for MAX3070E, MAX3071E, MAX3072E, MAX3073E, MAX3074E, MAX3075E, MAX3076E, MAX3077E, MAX3078E

General Description

The ZT307xE series devices are 3V differential data line transceivers for RS485/RS422 communication that consist of one driver and one receiver with high level of ESD protection. They are designed for balanced transmission lines interface that meet ANSI standard TIA/EIA-485-A and ISO 8482:1987(E) specifications.

The ZT307xE series devices span out with half or full duplex, data rate guaranteed at 250Kbps, 500Kbps or 16Mbps, and allow 1/8 unit load that fan out 256 devices sharing a common bus. The I/Os are enhanced-electrostatic discharge (ESD) protected, exceeding $\pm 15KV$ Human Body Model (HBM).

Applications

- RS422/RS485 communications
- Utility meters
- Industrial process control
- Building automation
- Level translators
- Transceivers for EMI-sensitive applications
- Routers and HUBs
- Industrial-controlled Local Area Networks
- Industrial PCs, embedded PCs and peripherals
- Industrial, security CATV and camera applications

ZT3072E

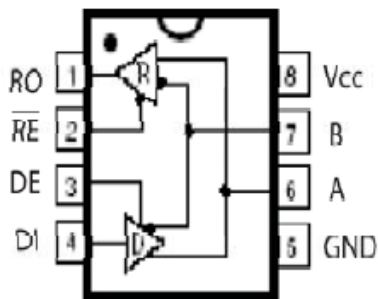

8-Pin PDIP/nSOIC/
MSOP

Product Selection Guide and Cross Reference

Part Number	Duplex	# of Tx/Rx	Data Rate (Mbps)	# of Tx/Rx on Bus	Slew Rate Limit	Low-Power Shutdown	Tx/Rx Enable	ESD on Tx/Rx	Package Types	Pin-to-Pin Cross Reference
ZT3070E	Full	1/1	0.250	256	Yes	Yes	Yes	± 15KV	14-PDIP 14-nSOIC	MAX3070E
ZT3071E	Full	1/1	0.250	256	Yes	No	No	± 15KV	8-PDIP 8-nSOIC 8-MSOP	MAX3071E
ZT3072E	Half	1/1	0.250	256	Yes	Yes	Yes	± 15KV	8-PDIP 8-nSOIC 8-MSOP	MAX3072E
ZT3073E	Full	1/1	0.5	256	Yes	Yes	Yes	± 15KV	14-PDIP 14-nSOIC	MAX3073E
ZT3074E	Full	1/1	0.5	256	Yes	No	No	± 15KV	8-PDIP 8-nSOIC 8-MSOP	MAX3074E
ZT3075E	Half	1/1	0.5	256	Yes	Yes	Yes	± 15KV	8-PDIP 8-nSOIC 8-MSOP	MAX3075E
ZT3076E	Full	1/1	16	256	No	Yes	Yes	± 15KV	14-PDIP 14-nSOIC	MAX3076E
ZT3077E	Full	1/1	16	256	No	No	No	± 15KV	8-PDIP 8-nSOIC 8-MSOP	MAX3077E
ZT3078E	Half	1/1	16	256	No	Yes	Yes	± 15KV	8-PDIP 8-nSOIC 8-MSOP	MAX3078E

Absolute Maximum Ratings

These are stress ratings only and functional operation of the device at these ratings or any other above those indicated in the operation sections of the specifications is not implied. Exposure to absolute maximum rating conditions for extended periods of time may affect reliability.

Power Supply, (Vcc) - 0.3V to +7.0V

Input Voltages

DI, DE, \overline{RE} - 0.3V to (Vcc +0.3V)

Differential Input Voltage, (VID) - 12V to +12V

A, B (VI) - 9V to +13V

Output Voltages

RO - 0.3V to +6.0V

Y, Z (A & B on Half Duplex) - 9V to +13.0V

Operating Temperature - 40°C to +85°C

Storage Temperature - 65°C to +150°C

Power Dissipation Per Package

8-pin PDIP (derate 9.09mW/°C above +70°C)722mW

8-pin nSOIC (derate 6.14mW/°C above +70°C)500mW

8-pin MSOP (derate 4.85mW/°C above +70°C)400mW

14-pin PDIP (derate 10.00mW/°C above +70°C)800mW

14-pin nSOIC (derate 8.33mW/°C above +70°C)667mW

Storage Considerations

Storage in a low humidity environment is preferred. Large high density plastic packages are moisture sensitive and should be stored in Dry Vapor Barrier Bags. Prior to usage, the parts should remain bagged and stored below 40°C and 60%RH. If the parts are removed from the bag, they should be used within 168 hours or stored in an environment at or below 20%RH. If the above conditions cannot be followed, the parts should be baked for 12 hours at 125°C in order to remove moisture prior to soldering. ASIX ships product in Dry Vapor Barrier Bags with a humidity indicator card and desiccant pack. The humidity indicator should be below 30%RH. The MSL of this product is 3.

The information furnished by ASIX has been carefully reviewed for accuracy and reliability. Its application or use, however, is solely the responsibility of the user. No responsibility of the use of this information become part of the terms and conditions of any subsequent sales agreement with ASIX. Specifications are subject to change without the responsibility for any infringement of patents or other rights of third parties which may result from its use. No license or proprietary rights are granted by implication or otherwise under any patent or patent rights of ASIX Electronics Corporation.

1 DC Electrical Characteristics

Unless otherwise stated, $V_{CC} = +3.3V$, $T_A = T_{min}$ to T_{max} , typical values apply at $V_{CC} = +3.3V$ and $T_A = 25^\circ C$.

Parameter	Condition	Min	Typ	Max	Units
Operating Voltage & Temperature					
Temperature	Industrial Grade	-40	25	85	$^\circ C$
Vcc Voltage Range		3.0	3.3	3.6	V
Supply Current					
Icc, Tx and Rx active	DI= Vcc /GND, DE= Vcc, \overline{RE} =GND, RS485 I/O=Open		0.5	1.5	mA
Icc, Tx active	DI= Vcc /GND, DE= Vcc, \overline{RE} = Vcc, RS485 I/O=Open		0.5	1.5	mA
Icc, Rx active	DI= Vcc /GND, DE=GND, \overline{RE} =GND, RS485 I/O=Open		0.5	1.5	mA
I _{SD} , Shutdown Current (except ZT3071E, ZT3074E, and ZT3077E)	DI= Vcc /GND, DE = GND, \overline{RE} = Vcc, RS485 I/O=Open		0.05	10	μA
TTL LOGIC Input, Driver					
Input Threshold Low, V_{IL}	$V_{CC} = +3.3V$, DE, DI, and \overline{RE}		1.4	0.8	V
Input Threshold High, V_{IH}	$V_{CC} = +3.3V$, DE, DI, and \overline{RE}	2	1.4		V
TTL LOGIC Output, Receiver					
Output Voltage Low, V_{OL}	$I_{OUT} = +4mA$, Input Differential Voltage = 200mV			0.4	V
Output Voltage High, V_{OH}	$I_{OUT} = -4mA$, Input Differential Voltage = 200mV	$V_{CC} - 0.3$			V
Output Leakage Current	Receiver Outputs Disabled, $V_{OUT} = 0.4V$ to $2.4V$		± 0.05	± 1	μA
Short Circuit Current	$V_{OUT} = 0V$ to V_{CC}			± 95	mA
Receiver Input					
Input Current	DE = 0V, $V_{CC} = 0V$ to $3.6V$, $V_{IN} = +12V$			125	μA
	DE = 0V, $V_{CC} = 0V$ to $3.6V$, $V_{IN} = -7V$			-75	μA
Differential Threshold Voltage, V_{TH}	$V_{CM} = 0V$, $V_{CC} = +3.3V$, $T_A = 25^\circ C$	-0.2		0.2	V
Input Hysteresis	$V_{CM} = 0V$		20		mV
Input Resistance, R_{IN}	$V_{CM} = -7V$ to $+12V$	96			K Ω
Transmitter Output					
Differential Output Voltage, V_{OD1}	No Load			V_{CC}	V
Differential Output Voltage, V_{OD2}	With $R_L = 50\Omega$, Refer to Figure 1. (RS422)	2		V_{CC}	V
	With $R_L = 27\Omega$, Refer to Figure 1. (RS485)	1.5		V_{CC}	V
Driver Common Mode Output, V_{OC}	With $R_L = 27\Omega$ or 50Ω . $C_L = 50pF$. Refer to Figure 3.			3	V
Change in Voltage Magnitude for Differential States, ΔV_{OD}	Differential Output Voltage, with $R_L = 27\Omega$ or 50Ω , Refer to Figure 1			0.2	V
Change in Voltage Magnitude for Common Mode States, ΔV_{OC}	Common-Mode Output Voltage, with $R_L = 27\Omega$ or 50Ω . Refer to Figure 2.			0.2	V
Transmitter Short-Circuit Current	$V_{OUT} = -7V$ to $+12V$. Refer to Figure 7.	-250		250	mA
Output Leakage Current, Full Duplex	$V_{IN} = +12V$, DE=GND, $V_{CC}=0V$ or $3.6V$			125	μA
	$V_{IN} = -7V$, DE=GND, $V_{CC}=0V$ or $3.6V$	-100			μA

2 AC Electrical Characteristics

2-1. AC Electrical Characteristics (ZT3076E/ZT3077E/ZT3078E)

Unless otherwise stated, $V_{CC} = +3.3V$, $T_A = T_{min}$ to T_{max} , typical values apply at $V_{CC} = +3.3V$ and $T_A = 25^\circ C$.

Parameter	Condition	Min	Typ	Max	Units
Transmitter Timing					
Transmitter Propagation t_{PLH}	$R_{DIFF} = 54\Omega$, $C_L = 50pF$. Refer to Figure 4.		35	75	ns
Transmitter Propagation t_{PHL}	$R_{DIFF} = 54\Omega$, $C_L = 50pF$. Refer to Figure 4.		35	75	ns
Transmitter Output Skew t_{SK}	$ t_{PLH} - t_{PHL} $		3	15	ns
Transmitter Rise/Fall Time	t_r , t_f , $R_{DIFF} = 54\Omega$, $C_L = 50pF$. Refer to Figure 4.		15	25	ns
Transmitter Output Enable	To Output HIGH, $C_L = 50pF$, $R_L = 110\Omega$. Refer to Figure 5.		200		ns
	To Output LOW, $C_L = 50pF$, $R_L = 110\Omega$. Refer to Figure 6.		200		ns
Transmitter Output Disable	From Output HIGH, $C_L = 50pF$, $R_L = 110\Omega$. Refer to Figure 5.		200		ns
	From Output LOW, $C_L = 50pF$, $R_L = 110\Omega$. Refer to Figure 6.		200		ns
Receiver Timing					
Receiver Propagation t_{PLH}	$C_L = 15pF$, Refer to Figure 9.		50	100	ns
Receiver Propagation t_{PHL}	$C_L = 15pF$, Refer to Figure 9.		50	100	ns
Differential Receiver Skew t_{SK}	$ t_{PLH} - t_{PHL} $		30		ns
Receiver Output Enable	To Output HIGH, $C_L = 15pF$. Refer to Figure 10.		50		ns
	To Output LOW, $C_L = 15pF$. Refer to Figure 11.		50		ns
Receiver Output Disable	From Output HIGH, $C_L = 15pF$. Refer to Figure 10.		50		ns
	From Output LOW, $C_L = 15pF$. Refer to Figure 11.		50		ns
Shutdown Timing (ZT3076E and ZT3078E ONLY)					
Time to Shutdown, t_{SHDN}			50	600	ns
Transmitter Enable from SHUTDOWN to Output HIGH	$C_L = 50pF$, $R_L = 110\Omega$. Refer to Figure 5.		200		ns
Transmitter Enable from SHUTDOWN to Output LOW	$C_L = 50pF$, $R_L = 110\Omega$. Refer to Figure 6.		200		ns
Receiver Enable from SHUTDOWN to Output HIGH	$C_L = 15pF$, $R_L = 1K\Omega$. Refer to Figure 11.		200		ns
Receiver Enable from SHUTDOWN to Output LOW	$C_L = 15pF$, $R_L = 1K\Omega$. Refer to Figure 11.		200		ns
Transceiver Throughput					
Maximum Data Rate	$R_L = 54\Omega$, $C_L = 50pF$, $T_A = 25^\circ C$	16			Mbps
ESD Tolerance					
ESD HBM	RS485 Inputs and Outputs		± 15		KV
ESD HBM ⁽¹⁾	All Pins		± 4		KV

(1) Tested in accordance with JEDEC Standard 22, Test Method A114-A and IEC 60749-26

2-2. AC Electrical Characteristics (ZT3073E/ZT3074E/ZT3075E)

Unless otherwise stated, VCC = +3.3V, TA = Tmin to Tmax, typical values apply at VCC = +3.3V and TA = 25°C.

Parameter	Condition	Min	Typ	Max	Units
Transmitter Timing					
Transmitter Propagation t _{PLH}	R _{DIFF} = 54Ω, C _L = 50pF. Refer to Figure 4.	180		800	ns
Transmitter Propagation t _{PHL}	R _{DIFF} = 54Ω, C _L = 50pF. Refer to Figure 4.	180		800	ns
Transmitter Output Skew t _{SK}	t _{PLH} - t _{PHL}			100	ns
Transmitter Rise/Fall Time	t _r , t _f , R _{DIFF} = 54Ω, C _L = 50pF. Refer to Figure 4.	200		800	ns
Transmitter Output Enable	To Output HIGH, C _L = 50pF, R _L = 110Ω. Refer to Figure 5.		200		ns
	To Output LOW, C _L = 50pF, R _L = 110Ω. Refer to Figure 6.		200		ns
Transmitter Output Disable	From Output HIGH, C _L = 50pF, R _L = 110Ω. Refer to Figure 5.		200		ns
	From Output LOW, C _L = 50pF, R _L = 110Ω. Refer to Figure 6.		200		ns
Receiver Timing					
Receiver Propagation t _{PLH}	C _L = 15pF, Refer to Figure 9.			200	ns
Receiver Propagation t _{PHL}	C _L = 15pF, Refer to Figure 9.			200	ns
Differential Receiver Skew t _{SK}	t _{PLH} - t _{PHL}		30		ns
Receiver Output Enable	To Output HIGH, C _L = 15pF. Refer to Figure 10.		50		ns
	To Output LOW, C _L = 15pF. Refer to Figure 11.		50		ns
Receiver Output Disable	From Output HIGH, C _L = 15pF. Refer to Figure 10.		50		ns
	From Output LOW, C _L = 15pF. Refer to Figure 11.		50		ns
Shutdown Timing (ZT3073E and ZT3075E ONLY)					
Time to Shutdown, t _{SHDN}			50	600	ns
Transmitter Enable from SHUTDOWN to Output HIGH	C _L = 50pF, R _L = 110Ω. Refer to Figure 5.		200		ns
Transmitter Enable from SHUTDOWN to Output LOW	C _L = 50pF, R _L = 110Ω. Refer to Figure 6.		200		ns
Receiver Enable from SHUTDOWN to Output HIGH	C _L = 15pF, R _L = 1KΩ. Refer to Figure 11.		200		ns
Receiver Enable from SHUTDOWN to Output LOW	C _L = 15pF, R _L = 1KΩ. Refer to Figure 11.		200		ns
Transceiver Throughput					
Maximum Data Rate	R _L = 54Ω, C _L = 50pF, TA = 25°C	0.5			Mbps
ESD Tolerance					
ESD HBM	RS485 Inputs and Outputs		±15		KV
ESD HBM ⁽¹⁾	All Pins		±4		KV

(1) Tested in accordance with JEDEC Standard 22, Test Method A114-A and IEC 60749-26

2-3. AC Electrical Characteristics (ZT3070E/ZT3071E/ZT3072E)

Unless otherwise stated, VCC = +3.3V, TA = Tmin to Tmax, typical values apply at VCC = +3.3V and TA = 25°C.

Parameter	Condition	Min	Typ	Max	Units
Transmitter Timing					
Transmitter Propagation t _{PLH}	R _{DIFF} = 54Ω, C _L = 50pF. Refer to Figure 4.	250	800	1500	ns
Transmitter Propagation t _{PHL}	R _{DIFF} = 54Ω, C _L = 50pF. Refer to Figure 4.	250	800	1500	ns
Transmitter Output Skew t _{SK}	t _{PLH} - t _{PHL}			200	ns
Transmitter Rise/Fall Time	t _r , t _f , R _{DIFF} = 54Ω, C _L = 50pF. Refer to Figure 4.	350		1600	ns
Transmitter Output Enable	To Output HIGH, C _L = 50pF, R _L = 110Ω. Refer to Figure 5.		200		ns
	To Output LOW, C _L = 50pF, R _L = 110Ω. Refer to Figure 6.		200		ns
Transmitter Output Disable	From Output HIGH, C _L = 50pF, R _L = 110Ω. Refer to Figure 5.		200		ns
	From Output LOW, C _L = 50pF, R _L = 110Ω. Refer to Figure 6.		200		ns
Receiver Timing					
Receiver Propagation t _{PLH}	C _L = 15pF, Refer to Figure 9.			200	ns
Receiver Propagation t _{PHL}	C _L = 15pF, Refer to Figure 9.			200	ns
Differential Receiver Skew t _{SK}	t _{PLH} - t _{PHL}		30		ns
Receiver Output Enable	To Output HIGH, C _L = 15pF. Refer to Figure 10.		50		ns
	To Output LOW, C _L = 15pF. Refer to Figure 11.		50		ns
Receiver Output Disable	From Output HIGH, C _L = 15pF. Refer to Figure 10.		50		ns
	From Output LOW, C _L = 15pF. Refer to Figure 11.		50		ns
Shutdown Timing (ZT3070E and ZT3072E ONLY)					
Time to Shutdown, t _{SHDN}			50	600	ns
Transmitter Enable from SHUTDOWN to Output HIGH	C _L = 50pF, R _L = 110Ω. Refer to Figure 5.		200		ns
Transmitter Enable from SHUTDOWN to Output LOW	C _L = 50pF, R _L = 110Ω. Refer to Figure 6.		200		ns
Receiver Enable from SHUTDOWN to Output HIGH	C _L = 15pF, R _L = 1KΩ. Refer to Figure 11.		200		ns
Receiver Enable from SHUTDOWN to Output LOW	C _L = 15pF, R _L = 1KΩ. Refer to Figure 11.		200		ns
Transceiver Throughput					
Maximum Data Rate	R _L = 54Ω, C _L = 50pF, TA = 25°C	0.25			Mbps
ESD Tolerance					
ESD HBM	RS485 Inputs and Outputs		±15		KV
ESD HBM ⁽¹⁾	All Pins		±4		KV

(1) Tested in accordance with JEDEC Standard 22, Test Method A114-A and IEC 60749-26

3 Pin Description

Pin Numbers			Pin Name	Pin Description
Half Duplex	Full Duplex			
ZT3072E	ZT3071E	ZT3070E		
ZT3075E	ZT3074E	ZT3073E		
ZT3078E	ZT3077E	ZT3076E		
1	2	2	RO	Receiver Output. If A>B by 200mV, then RO = HIGH; If A<B by 200mV, then RO = LOW
2	n/a	3	\overline{RE}	Receiver Output Enable Low active input. RO is high-Z when \overline{RE} = HIGH
3	n/a	4	DE	Driver Output Enable. The transmitter outputs, Y and Z, are enabled when DE = HIGH. The outputs are high-Z when DE = LOW.
4	3	5	DI	Driver Input. A low on DI forces output Y low and output Z high. A high on DI will bring output Y high and output Z low
5	4	6,7	GND	Analog Ground
n/a	5	9	Y	Non-inverting transmitter output
n/a	6	10	Z	Inverting transmitter output
6	n/a	n/a	A	Non-inverting transmitter output and non-inverting receiver input.
n/a	8	12	A	Non-inverting receiver input.
7	n/a	n/a	B	Inverting transmitter output and inverting receiver input.
n/a	7	11	B	Inverting receiver input
8	1	14	VCC	Power Supply Input, 5V \pm 10%
n/a	n/a	1,8,13	NC	No Connect, Not internally connected.

4 Circuit Description

The ZT307xE family are low-power transceivers for RS-485 and RS-422 communications. The RS-485 standard is ideal for multi-drop applications and for long-distance interfaces. The TIA/EIA-485 specification allows up to 256 drivers and 256 receivers to be connected to a data bus, making it an ideal choice for multi-drop applications. RS-485 transceivers are equipped with a wide (-7V to +12V) common mode range to accommodate ground potential differences since the cabling can be as long as 4,000 feet. As RS-485 is a differential interface, data is virtually immune to noise in the transmission line.

The ZT3070E, ZT3071E, ZT3072E, ZT3073E, ZT3074E, and ZT3075E are slew-rate limited, minimizing EMI and reducing reflections caused by improperly terminated cables.

RS-485 Transmitters

Each device in the ZT307xE family contains a differential output line transmitter that can drive voltage into multiple loads on a terminated two-wire pair, and a receiver that accepts a differential voltage down to 200mV. The transmitter's differential output can comply with RS-485 and also RS-422 standards. The typical voltage output swing with no load is 0V to Vcc. With worst case loading of 54 ohms across the differential outputs, the drivers can maintain greater than 1.5V voltage levels, which is more than adequate for a differential receiver to acknowledge a logic state. The 54 ohms is the equivalent of two 120 ohm termination resistors placed on each side of the transmission line and the input impedance of 256 receivers on the line.

The ZT3072E, ZT3075E, and ZT3078E transmitter have an enable control line which is active HIGH. A logic HIGH on DE (pin 3) will enable the differential outputs. A logic LOW on DE (pin 3) will disable the transmitter outputs. While disabled, the transmitter outputs are in high impedance.

RS-485 Receivers

Each transceiver contains one differential receiver that has an input sensitivity of 200mV. The input impedance of the receivers is typically 96K ohms. A wide common mode range of -7V to +12V allows for large ground potential differences between systems.

The ZT3072E, ZT3075E, and ZT3078E receivers have an enable control input. A logic LOW on \overline{RE} will enable the receiver, a logic HIGH on \overline{RE} will disable the receiver. The receivers are equipped with the fail-safe feature, which guarantees that the receiver output will be in a HIGH state when the input is left unconnected. This applies for both cases where the receiver inputs are either shorted or open.

The ZT3076E, ZT3077E, and ZT3078E can transmit and receive at data rates up to 16Mbps. The ZT3070E, ZT3071E, and ZT3072E are specified for data rates up to 250Kbps and the ZT3073E, ZT3074E, and ZT3075E are specified for data rates up to 500Kbps.

Bus Configuration

The ZT3070E, ZT3071E, ZT3073, ZT3074E, ZT3076E, and ZT3077E are full-duplex transceivers, while the ZT3072E, ZT3075E, and ZT3078E are half-duplex.

For full duplex, the devices are used as a four-wire bus transceiver with a configuration that the transmitters and receivers are moving data independent of each other. Transmit can occur on a dedicated two-wire pair and receive can occur on an adjacent two-wire pair, with each pair transferring data at up to 16Mbps.

Half duplex is a configuration where the transmitter outputs are connected to its receiver inputs. This application is common for two-wire interfaces where either the transmitter is active or the receiver is active. It is common to connect the enable inputs for the transmitter and receiver together so that a logic HIGH will enable the transmitter and disable the receiver. Conversely, a logic LOW will disable the transmitter and enable the receiver. Half-duplex configurations and these devices are designed for bidirectional data transmission on multipoint twisted-pair cables for applications, such as digital motor controllers, remote sensors and terminals, industrial process control, security stations and environmental control systems.

ESD Immunity

Electro-Static Discharge (ESD) is an important factor when implementing a serial port into a system, especially in harsh environmental conditions. These industrial strength devices provide extra protection against ESD and are intended for harsh environments where high-speed data communication is important.

All of the ZT307xE family of transceivers incorporate internal protection structures on all pins to protect against ESD charges encountered during handling and assembly. The driver outputs and receiver inputs have extra protection against static electricity as they are directly interfacing to the outside environment. As such, these pins protect against ESD of $\pm 15\text{KV}$ without damage in all states of the transceiver's operation from normal to powered down. After multiple ESD events, ASIX' s ZT307xE family of transceivers keep working without latchup. These devices eliminate the need for external transient suppressor diodes and the associated high capacitance loading, allowing reliable high-speed data communications.

The Human Body Model has been the generally accepted ESD testing method for semiconductors. This test is intended to simulate the human body' s potential to store electrostatic energy and discharge it to an integrated circuit upon close proximity or contact. This method will test the IC' s capability to withstand an ESD transient during normal handling such as in manufacturing areas where the ICs tend to be handled frequently.

5 Function Table

ZT3072E/ZT3075E/ZT3078E

DRIVER				RECEIVER		
Input DI	Enable DE	Outputs		Differential Inputs $V_{ID} = V_A - V_B$	Enable \overline{RE}	Output RO
		A	B			
H	H	H	L	$V_{ID} \leq -0.2V$	L	L
L	H	L	H	$-0.2V < V_{ID} < +0.2V$	L	U
X	L	Z	Z	$+0.2V \leq V_{ID}$	L	H
Open	H	H	L	X	H	Z
X	Open	Z	Z	X	Open	Z

ZT3071E/ZT3074E/ZT3077E

DRIVER				RECEIVER		
Input DI	Outputs		Differential Inputs $V_{ID} = V_A - V_B$	Output RO		
	Y	Z				
H	H	L	$V_{ID} \leq -0.2V$	L		
L	L	H	$-0.2V < V_{ID} < +0.2V$	U		
X	Z	Z	$+0.2V \leq V_{ID}$	H		
Open	H	L	X	Z		
X	Z	Z	X	Z		

ZT3070E/ZT3073E/ZT3076E

DRIVER				RECEIVER		
Input DI	Enable DE	Outputs		Differential Inputs $V_{ID} = V_A - V_B$	Enable \overline{RE}	Output RO
		Y	Z			
H	H	H	L	$V_{ID} \leq -0.2V$	L	L
L	H	L	H	$-0.2V < V_{ID} < +0.2V$	L	U
X	L	Z	Z	$+0.2V \leq V_{ID}$	L	H
Open	H	H	L	X	H	Z
X	Open	Z	Z	X	Open	Z

Note:

H = High Level; L = Low Level; Z = High Impedance; X = Irrelevant; U = Undetermined State.

6 Pin Configuration

ZT3072E/ZT3075E/ZT3078E

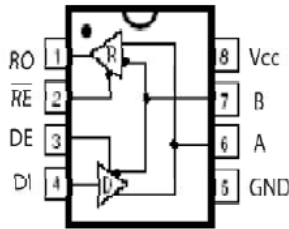

8-Pin PDIP/nSOIC/
MSOP

ZT3071E/ZT3074E/ZT3077E

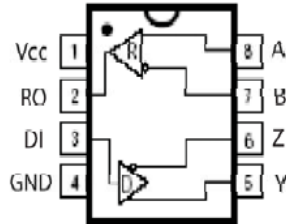

8-Pin PDIP/nSOIC/
MSOP

ZT3070E/ZT3073E/ZT3076E

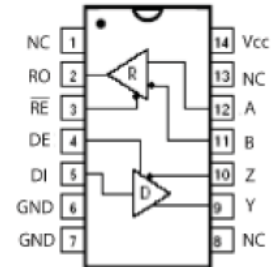

14-Pin PDIP/nSOIC

7 Typical Application Circuits

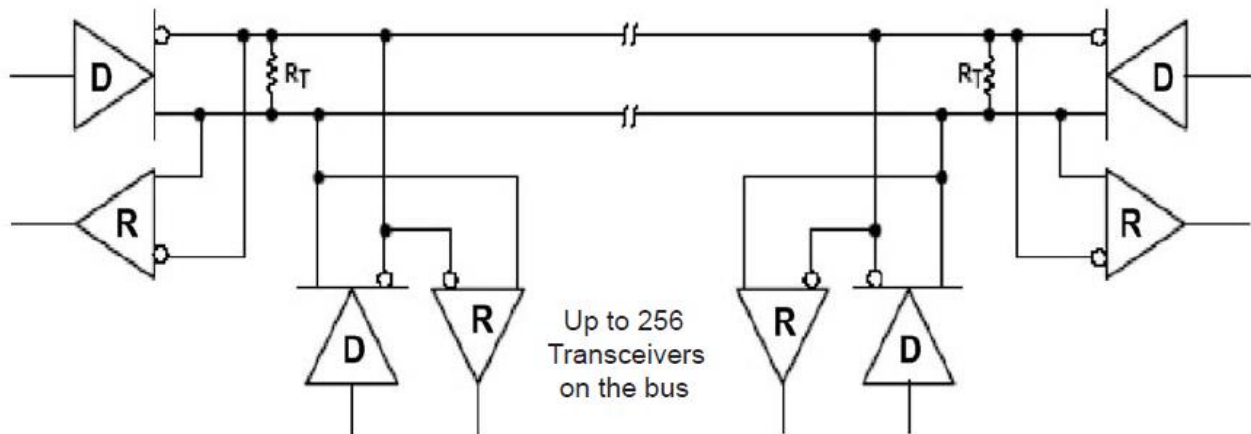

Notes:

- A. The bus should be terminated at both ends in its characteristic impedance of $R_T = Z_0$.
- B. Stub lengths off the main bus should be kept as short as possible.
- C. Can connect up to 256 devices on the same common bus.

8 Typical Test Circuits

Notes:

- A. The test load capacitance includes probe and test jig capacitance, unless otherwise specified.
- B. The signal generator had the following characteristics:
 Pulse rate = 1000 KHz, 50% duty cycle, $Z_0 = 50\ \Omega$, t_r & $t_f < 6\text{ns}$, unless otherwise specified.

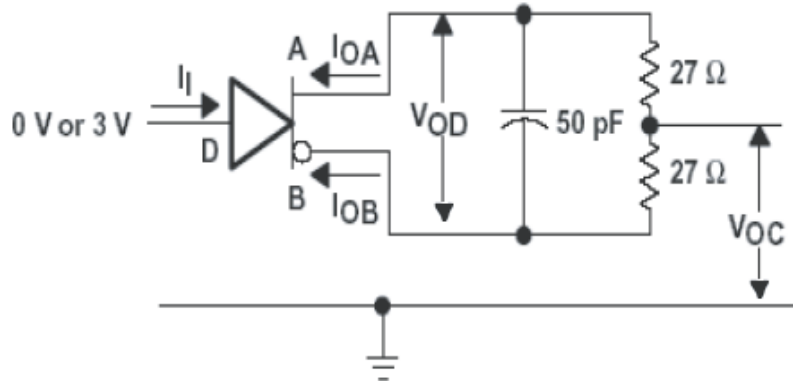

Figure 1. Driver Test Circuit, VOD and VOC Without Common-Mode Loading

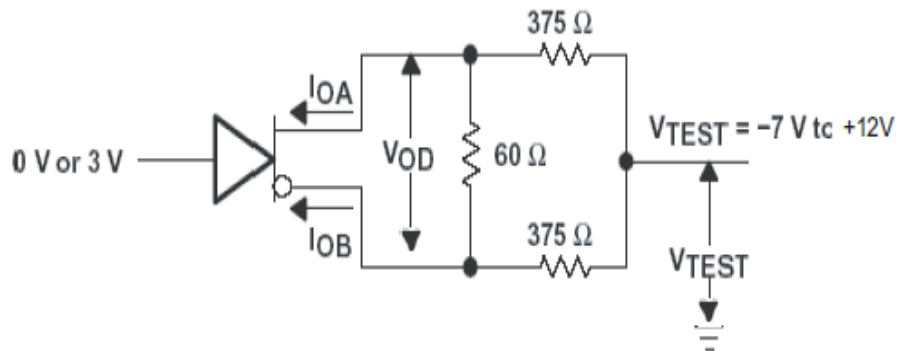

Figure 2. Driver Test Circuit, VOD With Common-Mode Loading

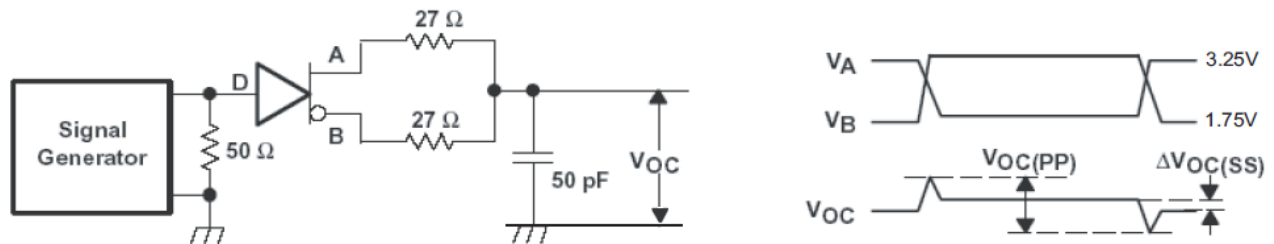

Figure 3. Driver Common-Mode Output Voltage (VOC) Test Circuit and Waveforms

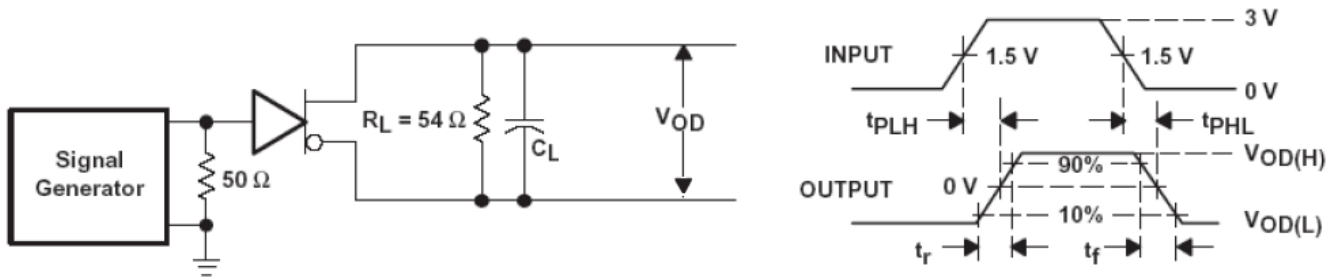

Figure 4. Driver Differential Output Voltage (V_{OD}) Switching Test Circuit and Waveforms

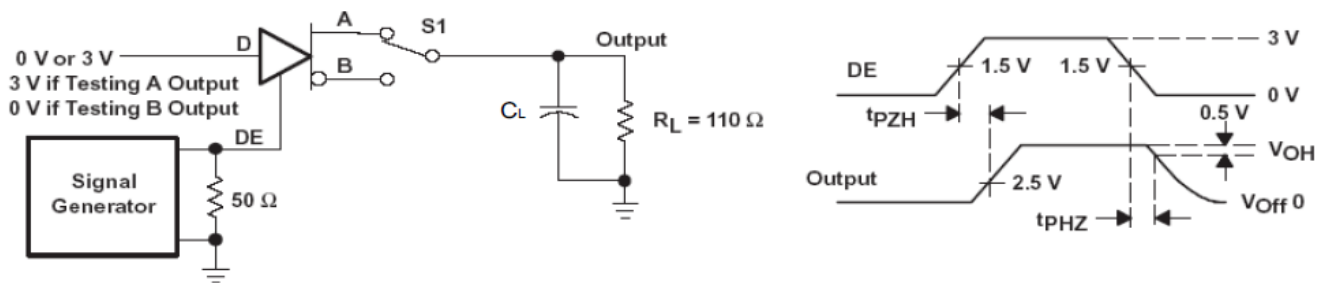

Figure 5. Driver Enable/Disable Test Circuit and Waveforms, High Output

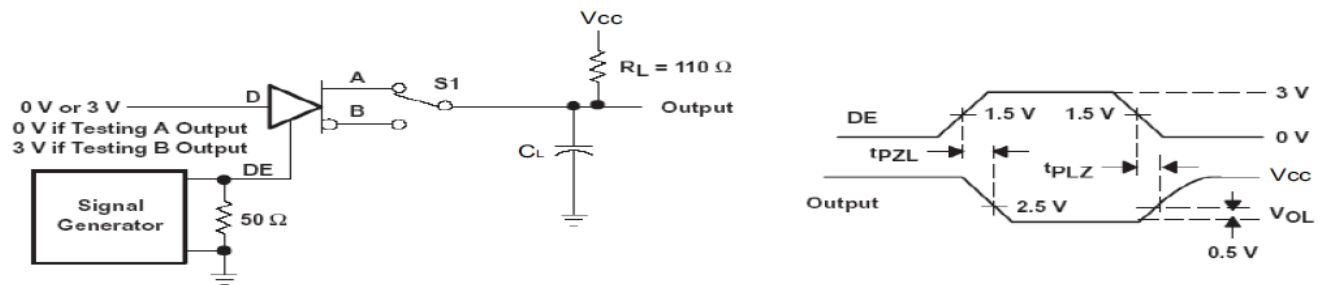

Figure 6. Driver Enable/Disable Test Circuit and Waveforms, Low Output

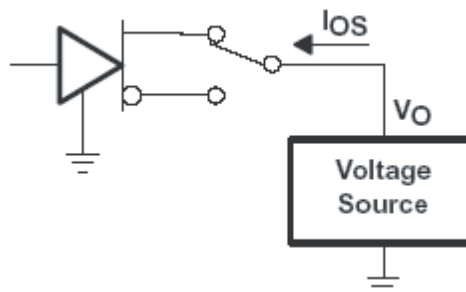

Figure 7. Driver Short-Circuit Test Configuration

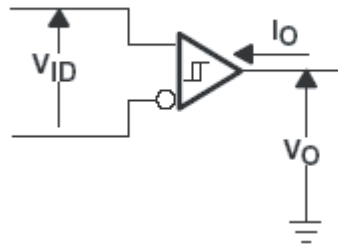

Figure 8. Receiver Parameter Definitions

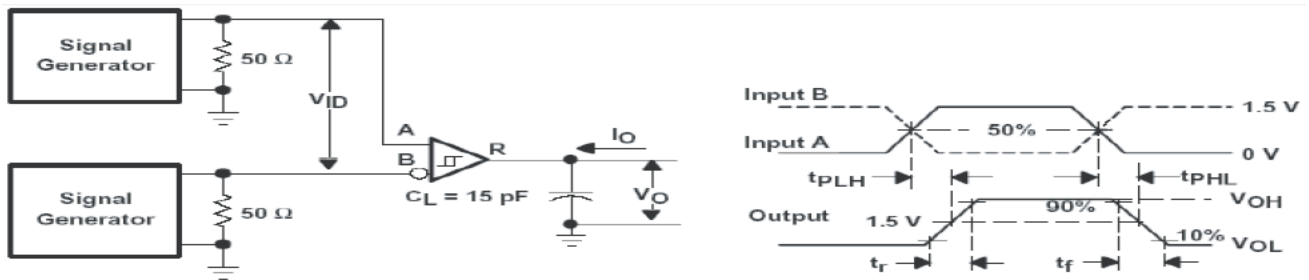

Figure 9. Receiver Propagation (t_{PLH} and t_{PHL}) Test Circuit and Waveforms

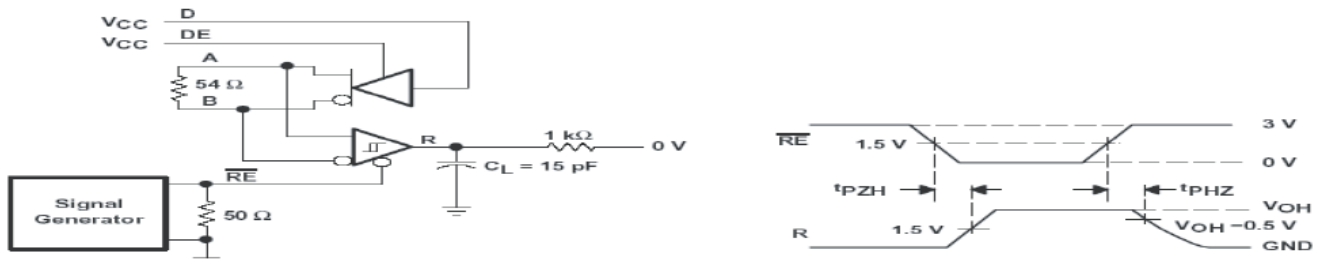

Figure 10. Receiver Output Enable/Disable Test Circuit and Waveforms, Data Output High

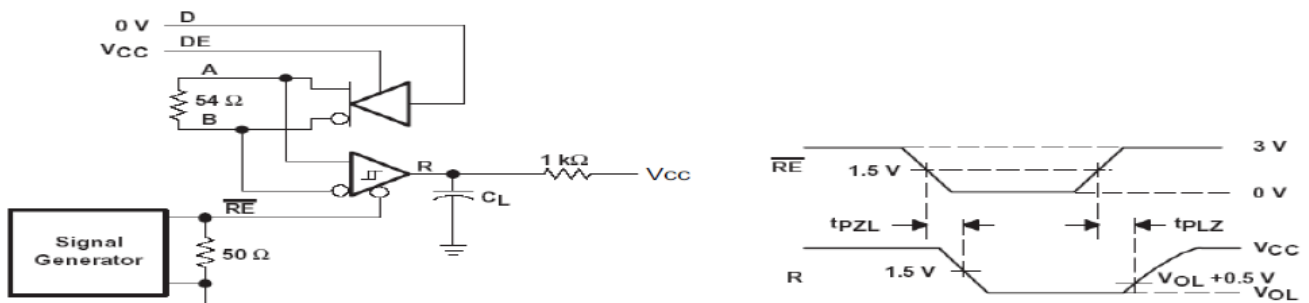
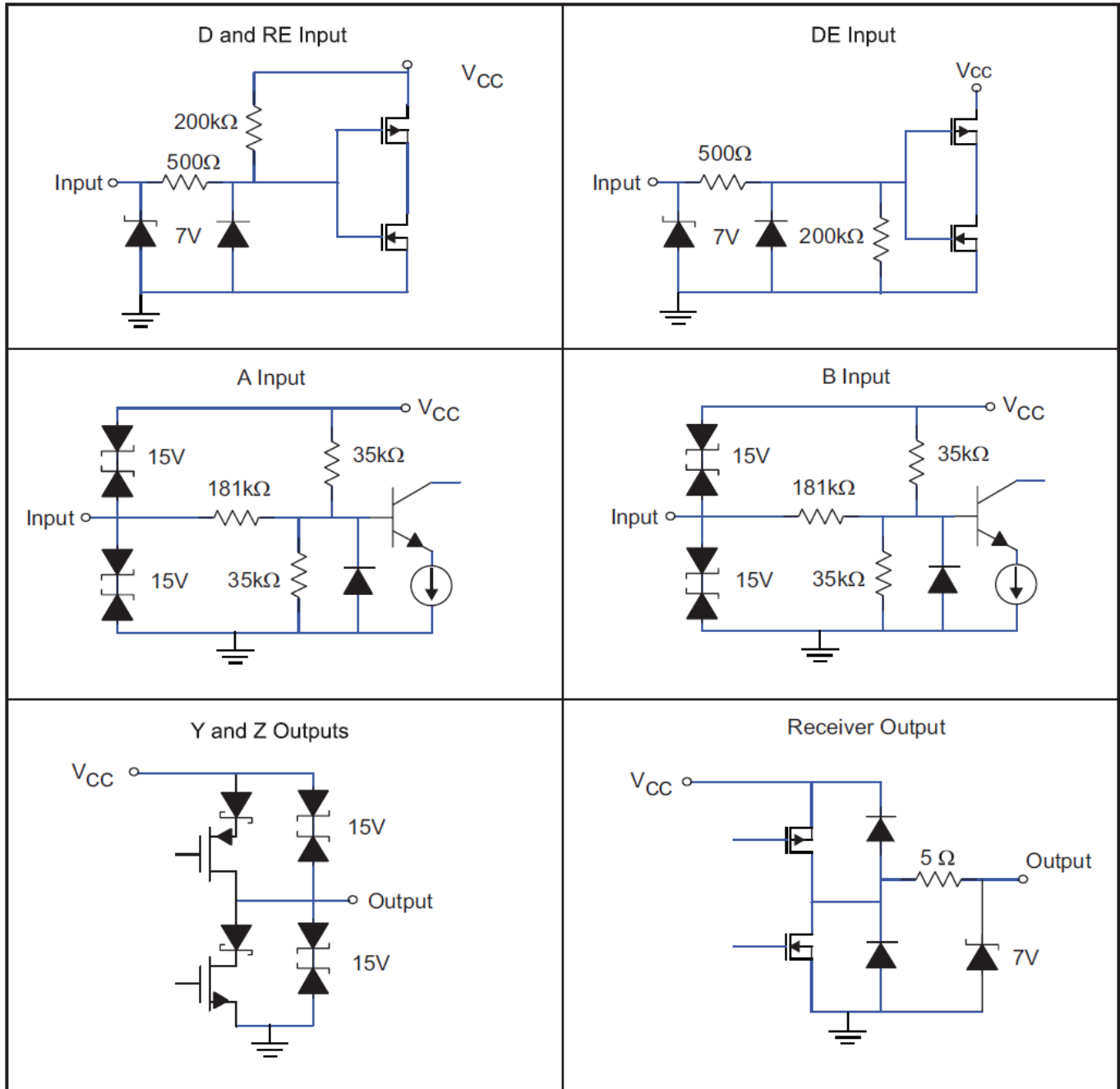
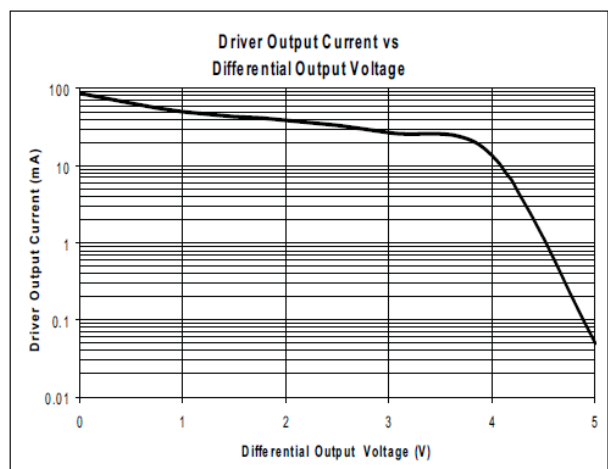
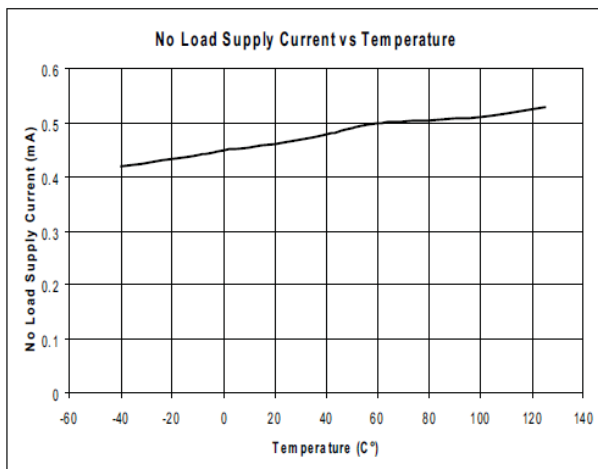
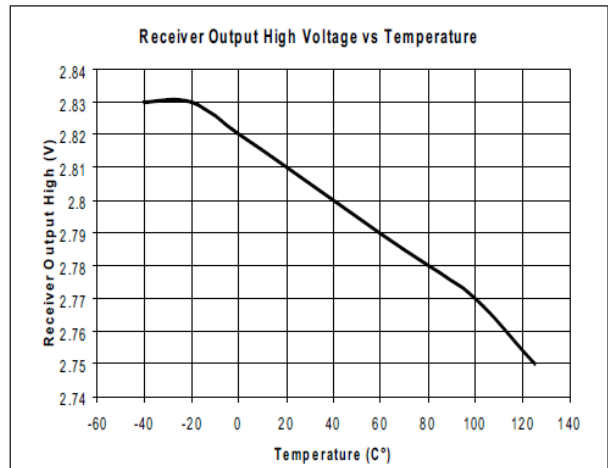
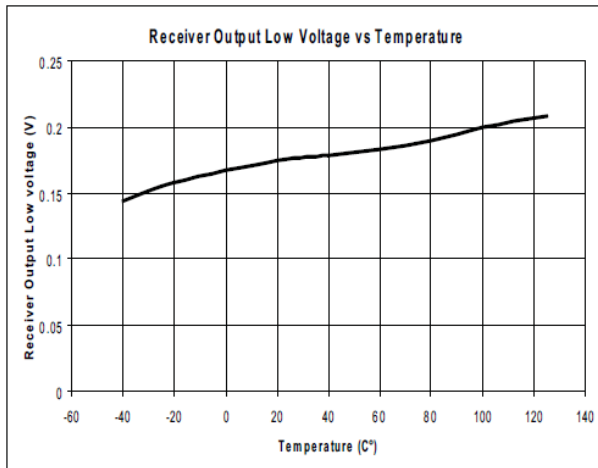
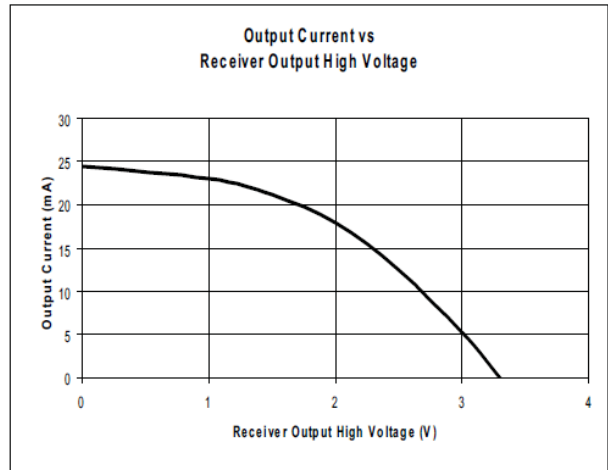
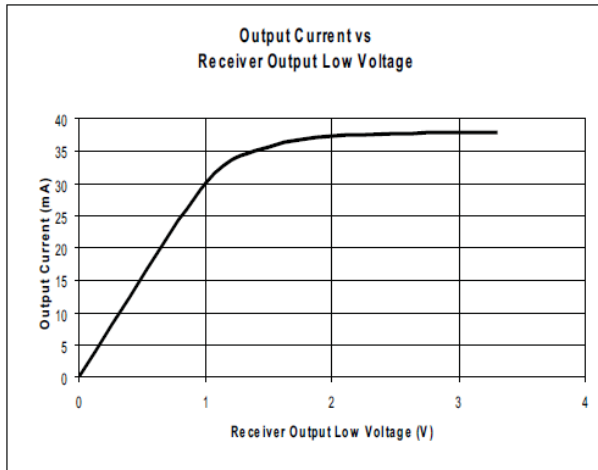

Figure 11. Receiver Output Enable/Disable Test Circuit and Waveforms, Data Output Low

9 Equivalent Input and Output Schematic Diagrams



10 Typical Performance Characteristics



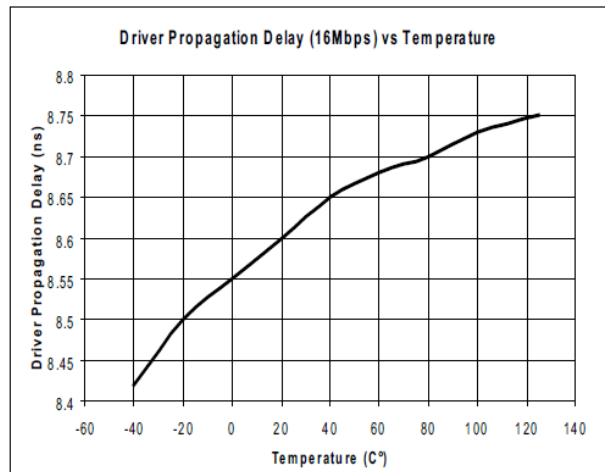
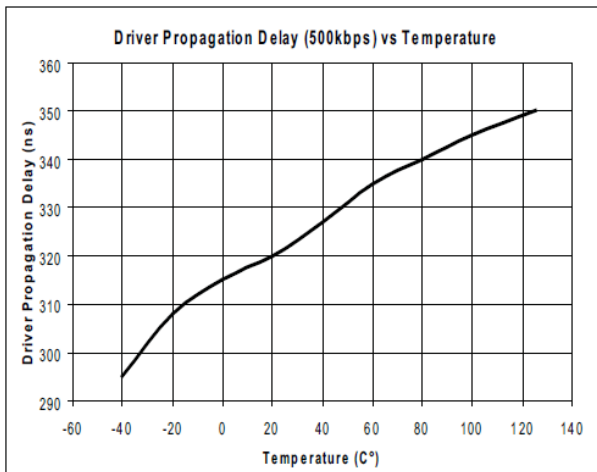
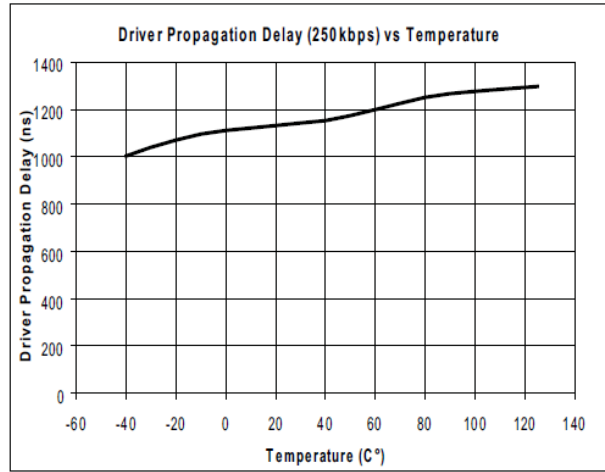
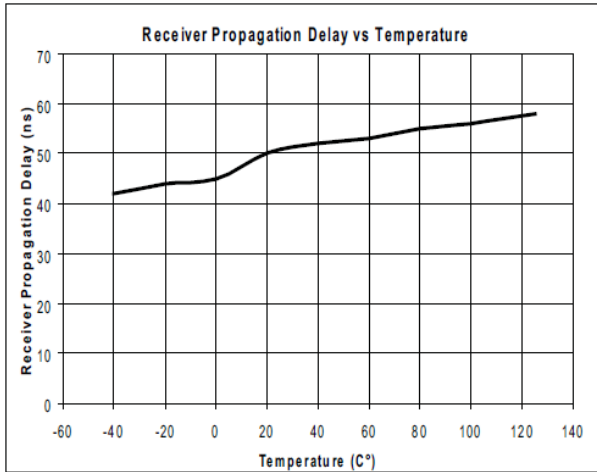

11 Package Information

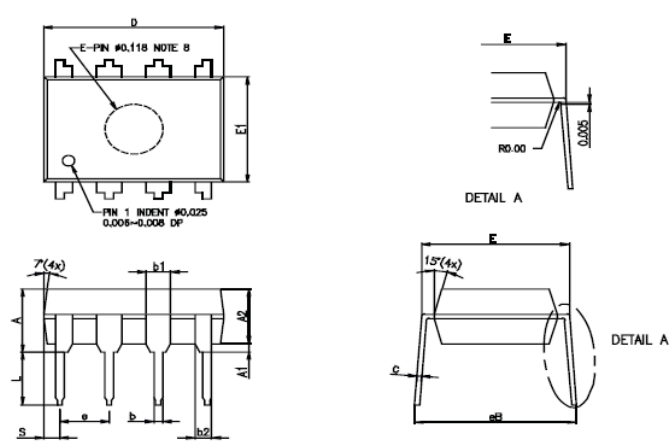

NOTE :

- CONTROLLING DIMENSION : INCH
- LEAD FRAME MATERIAL : C194
- DIMENSION D AND E1 DO NOT INCLUDE MOLD FLASH OR PROTRUSIONS. MOLD FLASH OR PROTRUSIONS SHALL NOT EXCEED 0.010" [0.25mm]
- DIMENSION "b1" DO NOT INCLUDE DAMBAR PROTRUSION. DAMBAR PROTRUSIONS SHALL NOT EXCEED 0.010" [0.25mm]. DISTANCE BETWEEN LEADS INCLUDING DAMBAR PROTRUSIONS TO BE 0.006" [0.13mm] MINIMUM.
- TOLERANCE : ±0.010" [0.25mm] UNLESS OTHERWISE SPECIFIED.
- OTHERWISE DIMENSION FOLLOW ACCEPTABLE SPEC.
- REFERENCE DOCUMENT : JEDEC SPEC MS-001-BA
- BOTTOM E-PIN INDENT ARE MARKED AS BELOW:

SYMBOLS	DIMENSIONS IN MILLIMETERS			DIMENSIONS IN INCHES		
	MIN	NOM	MAX	MIN	NOM	MAX
A	3.6	3.9	4.2	0.142	0.164	0.165
A1	0.38	—	—	0.015	—	—
A2	3.25	3.30	3.45	0.128	0.130	0.136
b	0.38	0.48	0.56	0.015	0.019	0.022
b1	1.48	1.58	1.88	0.058	0.062	0.074
b2	0.813	0.99	1.14	0.032	0.039	0.046
c	0.20	0.25	0.30	0.008	0.010	0.012
D	9.12	9.30	9.53	0.359	0.368	0.375
E	7.62	7.87	8.26	0.300	0.310	0.325
E1	6.20	6.35	6.60	0.244	0.250	0.260
e	—	2.54	—	—	0.100	—
eB	8.38	—	9.40	0.330	—	0.370
L	3.18	—	—	0.125	—	—
S	0.71	0.84	0.97	0.028	0.033	0.038

X : A ~ T
Y : 0 ~ 9

8-pin PDIP

CUSTOMER : ZYWYN CORPORATION

APPROVED BY: [Signature] DATE: 01/26/00

DRAW BY: [Signature] DATE: 01/26/00

CHECK BY: [Signature] DATE: 01/29/00

APPROVAL: [Signature] DATE: 01/29/00

APPROVAL: [Signature] DATE: 1/27/00

TITLE : 8L P-DIP PACKAGE OUTLINE DRAWING FOR MITSUMI

DWG. NO. PO-DIP-019 REV. 0

UNIT : INCH SCALE : 8/1 SHEET 1 OF 1

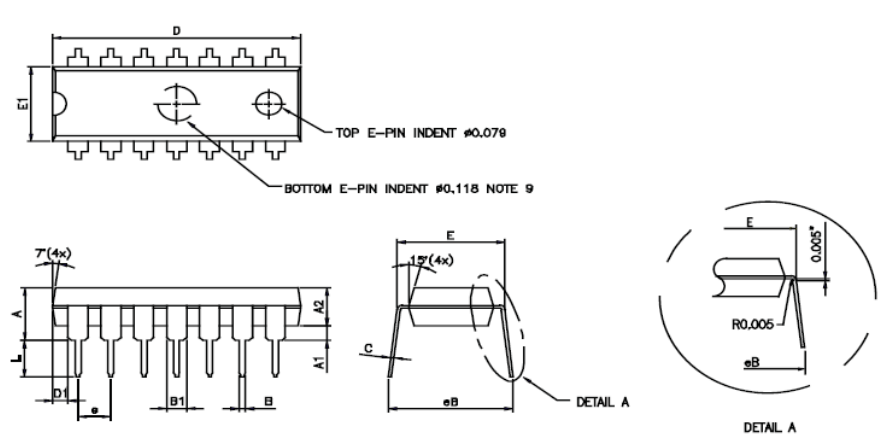

NOTES :

- CONTROLLING DIMENSION : INCH
- LEAD FRAME MATERIAL : C194
- PACKAGE DIMENSION EXCLUDE MOLDING FLASH
- AFTER SOLDER PLATING LEAD THICKNESS WILL BE 0.013" MAX
- AFTER SOLDER DIPPING LEAD THICKNESS WILL BE 0.020" MAX
- THE MAX. ALLOWABLE MOLDING FLASH IS 0.010"
- TOLERANCE : 0.002" UNLESS OTHERWISE SPECIFIED
- OTHERWISE DIMENSION FOLLOW ACCEPTABLE SPES
- THE BOTTOM E-PIN INDENT IS MARKED AS BELOW :

SYMBOLS	DIMENSIONS IN MILLIMETERS			DIMENSIONS IN INCHES		
	MIN	NOM	MAX	MIN	NOM	MAX
A	—	—	4.57	—	—	0.180
A1	0.38	—	—	0.015	—	—
A2	3.25	3.30	3.45	0.128	0.130	0.136
B	0.26	0.46	0.56	0.014	0.018	0.022
B1	1.14	1.27	1.52	0.045	0.050	0.060
C	0.20	0.25	0.33	0.008	0.010	0.013
D	18.19	18.15	19.30	0.744	0.754	0.760
D1	0.81	1.19	1.47	0.032	0.047	0.058
E	7.82	—	8.26	0.300	—	0.325
E1	6.35	6.50	6.65	0.250	0.256	0.262
e	—	2.54	—	—	0.100	—
L	3.18	—	—	0.125	—	—
eB	8.63	—	9.65	0.340	—	0.380

X : A-1
Y : 0-9

14L P-DIP

CUSTOMER : ZYWYN CORPORATION

APPROVED BY: [Signature] DATE: 05/12/00

DRAW BY: [Signature] DATE: 05/12/00

CHECK BY: [Signature] DATE: 05/12/00

APPROVAL: [Signature] DATE: 05/12/00

APPROVAL: [Signature] DATE: 05/12/00

TITLE : 14L P-DIP PACKAGE OUTLINE DRAWING

DWG. NO. PO-DIP-002 REV. 0

UNIT : INCH SCALE : 4/1 SHEET 1 OF 1

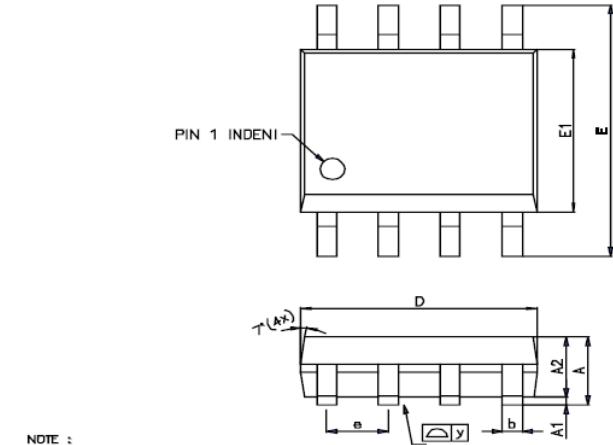

PIN 1 INDENT

GAGE PLANE

0.010

DETAIL A

0.015x45°

7(4x)

DETAIL A

8-pin nSOIC

NOTE :

1. CONTROLLING DIMENSION : INCH
2. LEAD FRAME MATERIAL : COPPER 194
3. DIMENSION "D" DOES NOT INCLUDE MOLD FLASH, TIE BAR BURRS AND GATE BURRS. MOLD FLASH, TIE BAR BURRS AND GATE BURRS SHALL NOT EXCEED 0.006[0.15mm] PER END. DIMENSION "E1" DOES NOT INCLUDE INTERLEAD FLASH. INTERLEAD FLASH SHALL NOT EXCEED 0.010[0.25mm] PER SIDE.
4. DIMENSION "b" DOES NOT INCLUDE DAMBAR PROTRUSION. ALLOWABLE DAMBAR PROTRUSION SHALL BE 0.003[0.08mm] TOTAL IN EXCESS OF THE "b" DIMENSION AT MAXIMUM MATERIAL CONDITION. DAMBAR CANNOT BE LOCATED ON THE LOWER RADII OR THE FOOT. MINIMUM SPACE BETWEEN PROTRUSION AND AN ADJACENT LEAD TO BE 0.0028[0.07mm]
5. TOLERANCE : ±0.010[0.25mm] UNLESS OTHERWISE SPECIFIED.
6. OTHERWISE DIMENSION FOLLOW ACCEPTABLE SPEC.
7. REFERENCE DOCUMENT : JEDEC SPEC MS-012

SYMBOLS	DIMENSIONS IN MILLIMETERS			DIMENSIONS IN INCHES		
	MIN	NOM	MAX	MIN	NOM	MAX
A	1.47	1.60	1.73	0.058	0.063	0.068
A1	0.10	—	0.25	0.004	—	0.010
A2	—	1.45	—	—	0.057	—
b	0.33	0.41	0.51	0.013	0.016	0.020
c	0.19	0.20	0.25	0.0075	0.008	0.0098
D	4.80	4.85	4.95	0.189	0.191	0.195
E	5.80	6.00	6.20	0.228	0.236	0.244
E1	3.80	3.90	4.00	0.150	0.154	0.157
e	—	1.27	—	—	0.050	—
L	0.40	0.71	1.27	0.016	0.028	0.060
y	—	—	0.076	—	—	0.003
ø	0"	—	8"	0"	—	8"

CUSTOMER :		ZYWYN CORPORATION	
APPROVED BY	DATE	TITLE	
DRAWN BY:	2/20/05	BL NARROW BODY SMALL	
CHECK BY:	2/20/05	OUTLINE PACKAGE DRAWING	
APPROVAL:		DWG. NO. PO-SOP-001	REV. 2
APPROVAL:		UNIT : INCH	SCALE : 16/1
APPROVAL:		SECRET 1 OF 1	

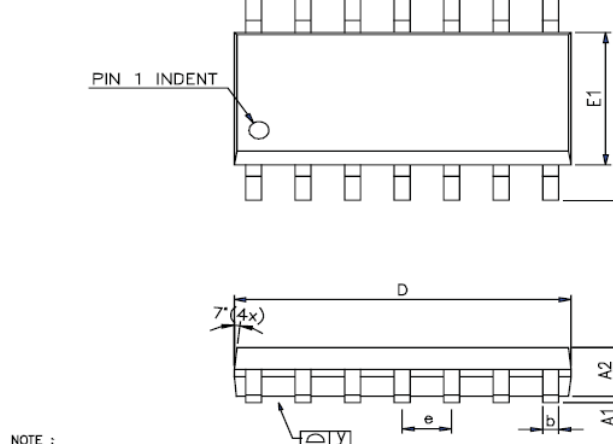

PIN 1 INDENT

GAGE PLANE

0.010

DETAIL A

0.015x45°

7(4x)

DETAIL A

14-pin nSOIC

NOTE :







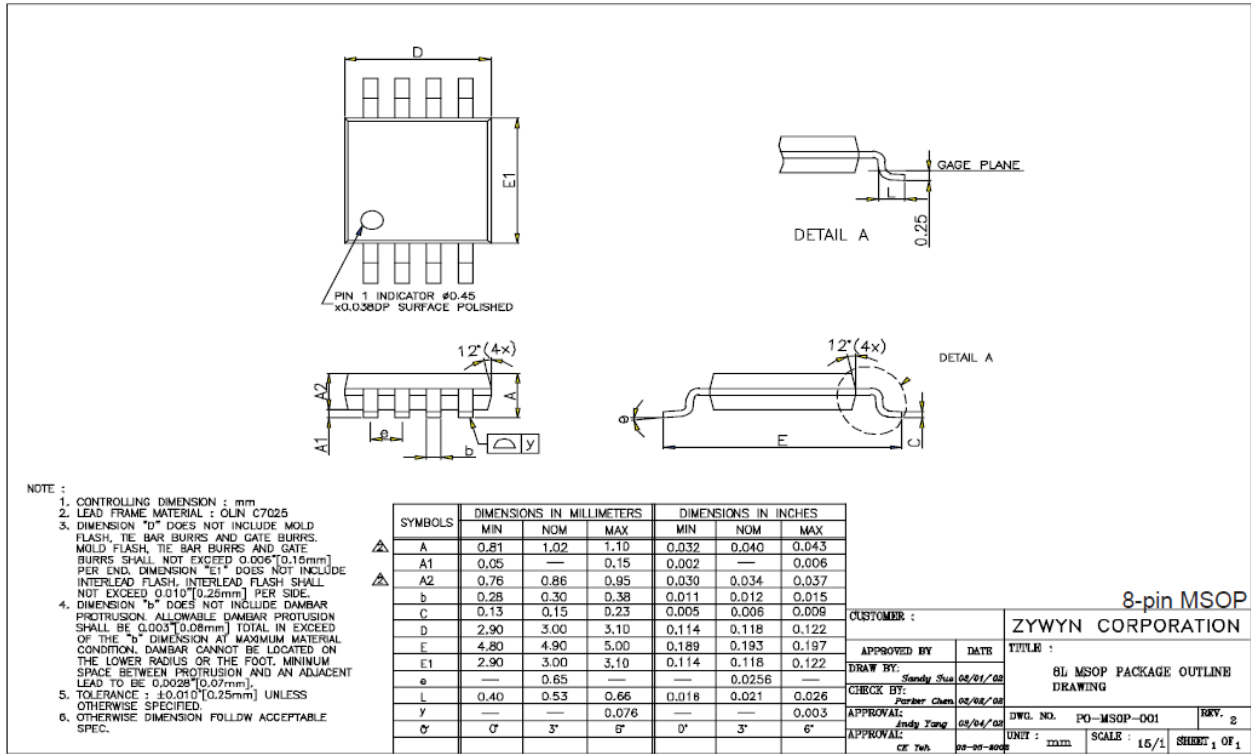

















1. CONTROLLING DIMENSION : INCH
2. LEAD FRAME MATERIAL : COPPER 194
3. DIMENSION "D" DOES NOT INCLUDE MOLD FLASH, TIE BAR BURRS AND GATE BURRS. MOLD FLASH, TIE BAR BURRS AND GATE BURRS SHALL NOT EXCEED 0.006[0.15mm] PER END. DIMENSION "E1" DOES NOT INCLUDE INTERLEAD FLASH. INTERLEAD FLASH SHALL NOT EXCEED 0.010[0.25mm] PER SIDE.
4. DIMENSION "b" DOES NOT INCLUDE DAMBAR PROTRUSION. ALLOWABLE DAMBAR PROTRUSION SHALL BE 0.003[0.08mm] TOTAL IN EXCESS OF THE "b" DIMENSION AT MAXIMUM MATERIAL CONDITION. DAMBAR CANNOT BE LOCATED ON THE LOWER RADII OR THE FOOT. MINIMUM SPACE BETWEEN PROTRUSION AND AN ADJACENT LEAD TO BE 0.0028[0.07mm]
5. TOLERANCE : ±0.010[0.25mm] UNLESS OTHERWISE SPECIFIED.
6. OTHERWISE DIMENSION FOLLOW ACCEPTABLE SPEC.
7. REFERENCE DOCUMENT : JEDEC SPEC MS-012

SYMBOLS	DIMENSIONS IN MILLIMETERS			DIMENSIONS IN INCHES		
	MIN	NOM	MAX	MIN	NOM	MAX
A	1.47	1.60	1.73	0.058	0.063	0.068
A1	0.10	—	0.25	0.004	—	0.010
A2	—	1.45	—	—	0.057	—
b	0.33	0.41	0.51	0.013	0.016	0.020
c	0.19	0.20	0.25	0.0075	0.008	0.0098
D	8.53	8.64	8.74	0.336	0.340	0.344
E	5.79	5.99	6.20	0.228	0.236	0.244
E1	3.81	3.91	3.98	0.150	0.154	0.157
e	—	1.27	—	—	0.050	—
L	0.40	0.71	1.27	0.016	0.028	0.060
y	—	—	0.076	—	—	0.003
ø	0"	—	8"	0"	—	8"

CUSTOMER :		ZYWYN CORPORATION	
APPROVED BY	DATE	TITLE	
DRAWN BY:	2/20/05	14L NARROW BODY SMALL	
CHECK BY:	2/20/05	OUTLINE PACKAGE DRAWING	
APPROVAL:		DWG. NO. PO-SOP-002	REV. 1
APPROVAL:		UNIT : INCH	SCALE : 12/1
APPROVAL:		SECRET 1 OF 1	



12 Ordering Information

Part Number	Temperature Range	Package Type	Green Package (Pb-Free & RoHS)	MOQ /Tube	MOQ /T&R
ZT3070LEEN	-40°C to +85 °C	14-pin nSOIC		100	2500
ZT3070LEEP	-40°C to +85 °C	14-pin PDIP		60	N/A
ZT3071LEEN	-40°C to +85 °C	8-pin nSOIC		100	2500
ZT3071LEEP	-40°C to +85 °C	8-pin PDIP		60	N/A
ZT3071LEEU	-40°C to +85 °C	8-pin MSOP		50	2500
ZT3072LEEN	-40°C to +85 °C	8-pin nSOIC		100	2500
ZT3072LEEP	-40°C to +85 °C	8-pin PDIP		60	N/A
ZT3072LEEU	-40°C to +85 °C	8-pin MSOP		50	2500
ZT3073LEEN	-40°C to +85 °C	14-pin nSOIC		100	2500
ZT3073LEEP	-40°C to +85 °C	14-pin PDIP		60	N/A
ZT3074LEEN	-40°C to +85 °C	8-pin nSOIC		100	2500
ZT3074LEEP	-40°C to +85 °C	8-pin PDIP		60	N/A
ZT3074LEEU	-40°C to +85 °C	8-pin MSOP		50	2500
ZT3075LEEN	-40°C to +85 °C	8-pin nSOIC		100	2500
ZT3075LEEP	-40°C to +85 °C	8-pin PDIP		60	N/A
ZT3075LEEU	-40°C to +85 °C	8-pin MSOP		50	2500
ZT3076LEEN	-40°C to +85 °C	14-pin nSOIC		100	2500
ZT3076LEEP	-40°C to +85 °C	14-pin PDIP		60	N/A
ZT3077LEEN	-40°C to +85 °C	8-pin nSOIC		100	2500
ZT3077LEEP	-40°C to +85 °C	8-pin PDIP		60	N/A
ZT3077LEEU	-40°C to +85 °C	8-pin MSOP		50	2500
ZT3078LEEN	-40°C to +85 °C	8-pin nSOIC		100	2500
ZT3078LEEP	-40°C to +85 °C	8-pin PDIP		60	N/A
ZT3078LEEU	-40°C to +85 °C	8-pin MSOP		50	2500

Please contact the factory for pricing, availability on Tape-and-Reel and Die Sales options.

13 Part Marking Information

TOPSIDE MARK INSTRUCTIONS:

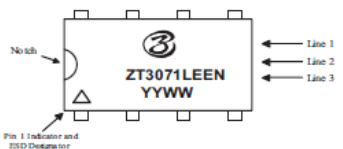

Line 1: Zywyn (logo)
 Line 2: Zywyn Part Number "ZT3071LEEN"
 Line 3: Date Code: (Last 2 digits of Prod. Year & Prod. Work Week)
 Note: Pin # 1 "△" Indicator Required

BOTTOMSIDE MARK INSTRUCTIONS:

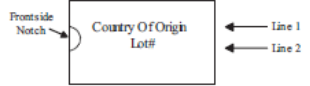

Line 1: Country of Origin (optional if Country of Origin is in Ejector Pin)
 Line 2: Lot Number

8/14-pin PDIP or 8/14-pin nSOIC

TOPSIDE MARK INSTRUCTIONS:

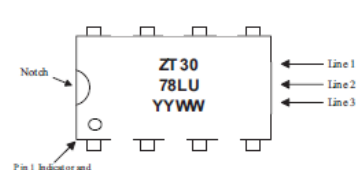

Line 1: Zywyn Part Name "ZT30"
 Line 2: Zywyn Part Number "78LU"
 Line 3: Date Code: (Last 2 digits of Prod. Year & Prod. Work Week)
 Note: Pin # 1 "○" Indicator Required if no mold dimple

BOTTOMSIDE MARK INSTRUCTIONS:

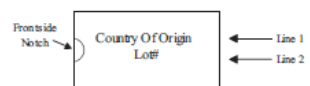

Line 1: Country of Origin (optional if Country of Origin is in Ejector Pin)
 Line 2: Lot Number

8-pin MSOP

Revision History

Revision	Date	Comment
V1.5	2012/06/01	Initial release to customers
V2.00	2015/05/05	1. Changed to ASIX Electronics Corp. logo, strings and contact information. 2. Added ASIX copyright legal header information. 3. Modified the Revision History table format.
V2.10	2020/06/22	Corrected Section 1. Information.



4F, No. 8, Hsin Ann Rd., HsinChu Science Park,
HsinChu, Taiwan, R.O.C.

TEL: 886-3-5799500

FAX: 886-3-5799558

Sales Email: sales@asix.com.tw

Support Email: support@asix.com.tw

Web: <http://www.asix.com.tw>