

64Mb B-die SLC NOR Specification

INFORMATION IN THIS DOCUMENT IS PROVIDED IN RELATION TO SAMSUNG PRODUCTS, AND IS SUBJECT TO CHANGE WITHOUT NOTICE.

NOTHING IN THIS DOCUMENT SHALL BE CONSTRUED AS GRANTING ANY LICENSE, EXPRESS OR IMPLIED, BY ESTOPPEL OR OTHERWISE,

TO ANY INTELLECTUAL PROPERTY RIGHTS IN SAMSUNG PRODUCTS OR TECHNOLOGY. ALL INFORMATION IN THIS DOCUMENT IS PROVIDED

ON AS "AS IS" BASIS WITHOUT GUARANTEE OR WARRANTY OF ANY KIND.

1. For updates or additional information about Samsung products, contact your nearest Samsung office.
2. Samsung products are not intended for use in life support, critical care, medical, safety equipment, or similar applications where Product failure could result in loss of life or personal or physical harm, or any military or defense application, or any governmental procurement to which special terms or provisions may apply.

* Samsung Electronics reserves the right to change products or specification without notice.

Document Title***64M Bit (4M x16) Sync Burst , Multi Bank NOR Flash Memory*****Revision History**

<u>Revision No.</u>	<u>History</u>	<u>Draft Date</u>	<u>Remark</u>
0.0	Initial Issue	November 9, 2005	Advance
0.5	Change Device ID from 2272H(Top Boot Block), 2273H(Bottom Boot Block) to 2252H(Top Boot Block), 2253H(Bottom Boot Block)	December 15, 2005	Preliminary
0.6	Bottom boot table is added	January 20, 2006	Preliminary
0.7	tAVDH is changed to 2ns at all frequency	February 07,2006	Preliminary
1.0	Specification is finalized	August 28, 2006	
1.1	"Asynchronous mode may not support read following four sequential invalid read condition within 200ns." is added	September 08, 2006	

64M Bit (4M x16) Sync Burst , Multi Bank NOR Flash Memory

FEATURES

- Single Voltage, 1.7V to 1.95V for Read and Write operations
- Organization
 - 4,194,304 x 16 bit (Word Mode Only)
- Read While Program/Erase Operation
- Multiple Bank Architecture
 - 16 Banks (4Mb Partition)
- OTP Block : Extra 256Byte block
- Read Access Time (@ CL=30pF)
 - Asynchronous Random Access Time : 90ns (54MHz) / 80ns (66MHz)
 - Synchronous Random Access Time : 88.5ns (54MHz) / 70ns (66MHz)
 - Burst Access Time : 14.5ns (54MHz) / 11ns (66MHz)
- Burst Length :
 - Continuous Linear Burst
 - Linear Burst : 8-word & 16-word with No-wrap & Wrap
- Block Architecture
 - Eight 4Kword blocks and one hundreds twenty seven 32Kword blocks
 - Bank 0 contains eight 4 Kword blocks and seven 32Kword blocks
 - Bank 1 ~ Bank 15 contain one hundred twenty 32Kword blocks
- Reduce program time using the VPP
- Support Single & Quad word accelerate program
- Power Consumption (Typical value, CL=30pF)
 - Burst Access Current : 30mA
 - Program/Erase Current : 15mA
 - Read While Program/Erase Current : 40mA
 - Standby Mode/Auto Sleep Mode : 15uA
- Block Protection/Unprotection
 - Using the software command sequence
 - Last two boot blocks are protected by WP=VIL
 - All blocks are protected by VPP=VIL
- Handshaking Feature
 - Provides host system with minimum latency by monitoring RDY
- Erase Suspend/Resume
- Program Suspend/Resume
- Unlock Bypass Program/Erase
- Hardware Reset ($\overline{\text{RESET}}$)
- Data Polling and Toggle Bits
 - Provides a software method of detecting the status of program or erase completion
- Endurance
 - 100K Program/Erase Cycles Minimum
- Data Retention : 10 years
- Extended Temperature : -25°C ~ 85°C
- Support Common Flash Memory Interface
- Low Vcc Write Inhibit
- Package : TBD

GENERAL DESCRIPTION

The K8A6415E featuring single 1.8V power supply is a 64Mbit Muxed Burst Multi Bank Flash Memory organized as 4Mb x 16. The memory architecture of the device is designed to divide its memory arrays into 135 blocks with independent hardware protection. This block architecture provides highly flexible erase and program capability. The K8A6415E NOR Flash consists of sixteen banks. This device is capable of reading data from one bank while programming or erasing in the other bank. Regarding read access time, the K8A6415E provides an 14.5ns burst access time and an 80ns initial access time at 54MHz. At 66MHz, the K8A6415E provides an 11ns burst access time and 70ns initial access time. The device performs a program operation in units of Single 16 bits (word) and an erase operation in units of a block. Single or multiple blocks can be erased. The block erase operation is completed within typically 0.7 sec. The device requires 15mA as program/erase current in the extended temperature ranges. The K8A6415E NOR Flash Memory is created by using Samsung's advanced CMOS process technology.

PIN DESCRIPTION

Pin Name	Pin Function
A0 - A21	Address Inputs
DQ0 - DQ15	Data input/output
$\overline{\text{CE}}$	Chip Enable
$\overline{\text{OE}}$	Output Enable
$\overline{\text{RESET}}$	Hardware Reset Pin
VPP	Accelerates Programming
$\overline{\text{WE}}$	Write Enable
$\overline{\text{WP}}$	Hardware Write Protection Input
CLK	Clock
RDY	Ready Output
$\overline{\text{AVD}}$	Address Valid Input
Vcc	Power Supply
Vss	Ground

SAMSUNG ELECTRONICS CO., LTD. reserves the right to change products and specifications without notice.

Package Diagram

TBD

FUNCTIONAL BLOCK DIAGRAM

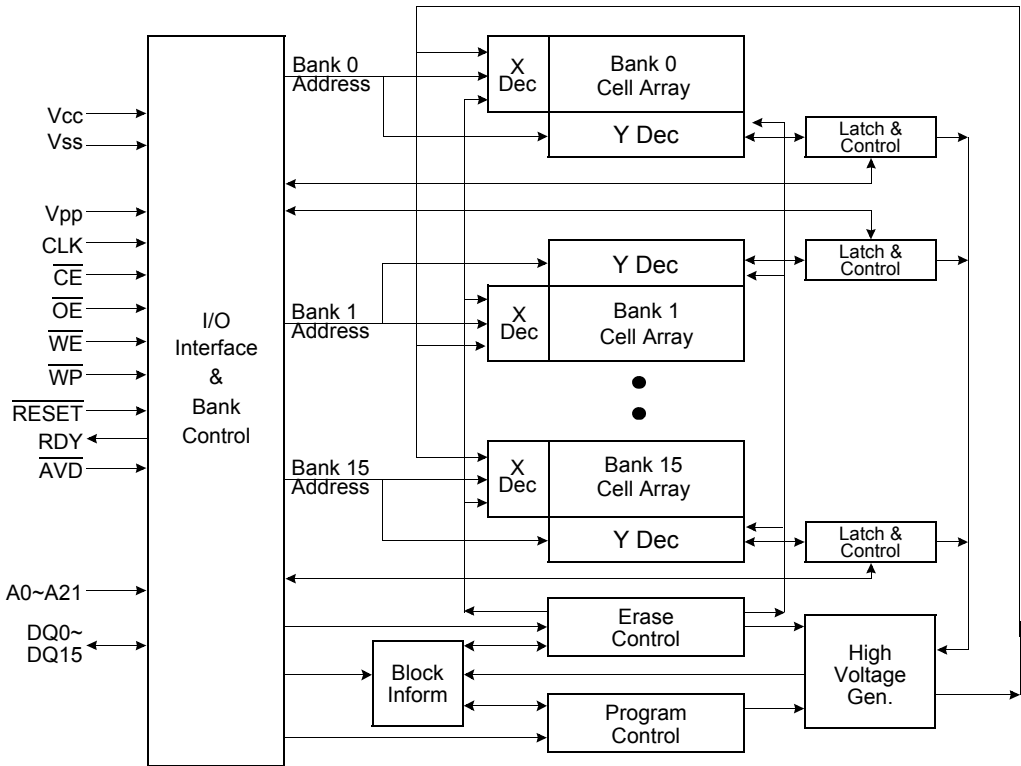

ORDERING INFORMATION

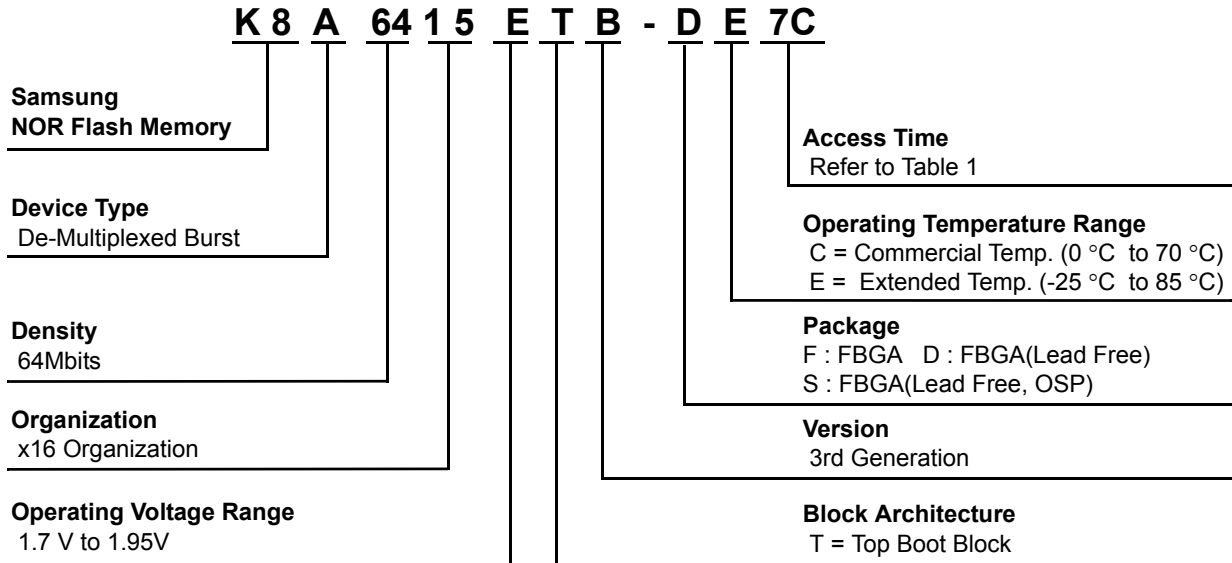

Table 1. PRODUCT LINE-UP

	K8A6415E					
	Synchronous/Burst			Asynchronous		
	Speed Option	7B (54MHz)	7C (66MHz)	Speed Option	7B (54MHz)	7C (66MHz)
V _{CC} =1.7V-1.95V	Max. Initial Access Time (t _I AA, ns)	88.5	70	Max Access Time (t _{AA} , ns)	90	80
	Max. Burst Access Time (t _B A, ns)	14.5	11	Max $\overline{\text{CE}}$ Access Time (t _{CE} , ns)	90	80
	Max. $\overline{\text{OE}}$ Access Time (t _{OE} , ns)	20	20	Max $\overline{\text{OE}}$ Access Time (t _{OE} , ns)	20	20

Table 2. K8A6415E DEVICE BANK DIVISIONS

Bank 0		Bank 1 ~ Bank 15	
Mbit	Block Sizes	Mbit	Block Sizes
4 Mbit	Eight 4Kwords, Seven 32Kwords	60 Mbit	One hundred twenty 32Kwords

Table 3-1. Top boot block Address Table(K8A6415ETB)

Bank	Block	Block Size	(x16) Address Range
Bank0	BA134	4 Kwords	3FF000h-3FFFFFFh
	BA133	4 Kwords	3FE000h-3FEFFFFh
	BA132	4 Kwords	3FD000h-3FDFFFFh
	BA131	4 Kwords	3FC000h-3FCFFFFh
	BA130	4 Kwords	3FB000h-3FBFFFFh
	BA129	4 Kwords	3FA000h-3FAFFFFh
	BA128	4 Kwords	3F9000h-3F9FFFFh
	BA127	4 Kwords	3F8000h-3F8FFFFh
	BA126	32 Kwords	3F0000h-3F7FFFFh
	BA125	32 Kwords	3E8000h-3E7FFFFh
	BA124	32 Kwords	3E0000h-3E7FFFFh
	BA123	32 Kwords	3D8000h-3D7FFFFh
	BA122	32 Kwords	3D0000h-3D7FFFFh
	BA121	32 Kwords	3C8000h-3C7FFFFh
BA120	32 Kwords	3C0000h-3C7FFFFh	
Bank1	BA119	32 Kwords	3B8000h-3B7FFFFh
	BA118	32 Kwords	3B0000h-3B7FFFFh
	BA117	32 Kwords	3A8000h-3A7FFFFh
	BA116	32 Kwords	3A0000h-3A7FFFFh
	BA115	32 Kwords	398000h-397FFFFh
	BA114	32 Kwords	390000h-397FFFFh
	BA113	32 Kwords	388000h-387FFFFh
Bank2	BA112	32 Kwords	380000h-387FFFFh
	BA111	32 Kwords	378000h-377FFFFh
	BA110	32 Kwords	370000h-377FFFFh
	BA109	32 Kwords	368000h-367FFFFh
	BA108	32 Kwords	360000h-367FFFFh
	BA107	32 Kwords	358000h-357FFFFh
	BA106	32 Kwords	350000h-357FFFFh
Bank3	BA105	32 Kwords	348000h-347FFFFh
	BA104	32 Kwords	340000h-347FFFFh
	BA103	32 Kwords	338000h-337FFFFh
	BA102	32 Kwords	330000h-337FFFFh
	BA101	32 Kwords	328000h-327FFFFh
	BA100	32 Kwords	320000h-327FFFFh
	BA99	32 Kwords	318000h-317FFFFh
Bank4	BA98	32 Kwords	310000h-317FFFFh
	BA97	32 Kwords	308000h-307FFFFh
	BA96	32 Kwords	300000h-307FFFFh
	BA95	32 Kwords	2F8000h-2F7FFFFh
	BA94	32 Kwords	2F0000h-2F7FFFFh
	BA93	32 Kwords	2E8000h-2E7FFFFh
	BA92	32 Kwords	2E0000h-2E7FFFFh
	BA91	32 Kwords	2D8000h-2D7FFFFh
Bank4	BA90	32 Kwords	2D0000h-2D7FFFFh
	BA89	32 Kwords	2C8000h-2C7FFFFh
	BA88	32 Kwords	2C0000h-2C7FFFFh

Table 3-1. Top boot block Address Table(K8A6415ETB)

Bank	Block	Block Size	(x16) Address Range
Bank5	BA87	32 Kwords	2B8000h-2BFFFFh
	BA86	32 Kwords	2B0000h-2B7FFFh
	BA85	32 Kwords	2A8000h-2AFFFFh
	BA84	32 Kwords	2A0000h-2A7FFFh
	BA83	32 Kwords	298000h-29FFFFh
	BA82	32 Kwords	290000h-297FFFh
	BA81	32 Kwords	288000h-28FFFFh
Bank6	BA80	32 Kwords	280000h-287FFFh
	BA79	32 Kwords	278000h-27FFFFh
	BA78	32 Kwords	270000h-277FFFh
	BA77	32 Kwords	268000h-26FFFFh
	BA76	32 Kwords	260000h-267FFFh
	BA75	32 Kwords	258000h-25FFFFh
	BA74	32 Kwords	250000h-257FFFh
Bank7	BA73	32 Kwords	248000h-24FFFFh
	BA72	32 Kwords	240000h-247FFFh
	BA71	32 Kwords	238000h-23FFFFh
	BA70	32 Kwords	230000h-237FFFh
	BA69	32 Kwords	228000h-22FFFFh
	BA68	32 Kwords	220000h-227FFFh
	BA67	32 Kwords	218000h-21FFFFh
Bank8	BA66	32 Kwords	210000h-217FFFh
	BA65	32 Kwords	208000h-20FFFFh
	BA64	32 Kwords	200000h-207FFFh
	BA63	32 Kwords	1F8000h-1FFFFFh
	BA62	32 Kwords	1F0000h-1F7FFFh
	BA61	32 Kwords	1E8000h-1EFFFFh
	BA60	32 Kwords	1E0000h-1E7FFFh
Bank9	BA59	32 Kwords	1D8000h-1DFFFFh
	BA58	32 Kwords	1D0000h-1D7FFFh
	BA57	32 Kwords	1C8000h-1CFFFFh
	BA56	32 Kwords	1C0000h-1C7FFFh
	BA55	32 Kwords	1B8000h-1BFFFFh
	BA54	32 Kwords	1B0000h-1B7FFFh
	BA53	32 Kwords	1A8000h-1AFFFFh
Bank10	BA52	32 Kwords	1A0000h-1A7FFFh
	BA51	32 Kwords	198000h-19FFFFh
	BA50	32 Kwords	190000h-197FFFh
	BA49	32 Kwords	188000h-18FFFFh
	BA48	32 Kwords	180000h-187FFFh
	BA47	32 Kwords	178000h-17FFFFh
Bank10	BA46	32 Kwords	170000h-177FFFh
	BA45	32 Kwords	168000h-16FFFFh
	BA44	32 Kwords	160000h-167FFFh
	BA43	32 Kwords	158000h-15FFFFh
Bank10	BA42	32 Kwords	150000h-157FFFh

Table 3-1. Top boot block Address Table(K8A6415ETB)

Bank	Block	Block Size	(x16) Address Range
Bank10	BA41	32 Kwords	148000h-14FFFFh
	BA40	32 Kwords	140000h-147FFFh
Bank11	BA39	32 Kwords	138000h-13FFFFh
	BA38	32 Kwords	130000h-137FFFh
	BA37	32 Kwords	128000h-12FFFFh
	BA36	32 Kwords	120000h-127FFFh
	BA35	32 Kwords	118000h-11FFFFh
	BA34	32 Kwords	110000h-117FFFh
	BA33	32 Kwords	108000h-10FFFFh
	BA32	32 Kwords	100000h-107FFFh
Bank12	BA31	32 Kwords	0F8000h-0FFFFFh
	BA30	32 Kwords	0F0000h-0F7FFFh
	BA29	32 Kwords	0E8000h-0EFFFFh
	BA28	32 Kwords	0E0000h-0E7FFFh
	BA27	32 Kwords	0D8000h-0DFFFFh
	BA26	32 Kwords	0D0000h-0D7FFFh
	BA25	32 Kwords	0C8000h-0CFFFFh
	BA24	32 Kwords	0C0000h-0C7FFFh
Bank13	BA23	32 Kwords	0B8000h-0BFFFFh
	BA21	32 Kwords	0B0000h-0B7FFFh
	BA21	32 Kwords	0A8000h-0AFFFFh
	BA20	32 Kwords	0A0000h-0A7FFFh
	BA19	32 Kwords	098000h-09FFFFh
	BA18	32 Kwords	090000h-097FFFh
	BA17	32 Kwords	088000h-08FFFFh
Bank14	BA16	32 Kwords	080000h-087FFFh
	BA15	32 Kwords	078000h-07FFFFh
	BA14	32 Kwords	070000h-077FFFh
	BA13	32 Kwords	068000h-06FFFFh
	BA12	32 Kwords	060000h-067FFFh
	BA11	32 Kwords	058000h-05FFFFh
	BA10	32 Kwords	050000h-057FFFh
	BA9	32 Kwords	048000h-04FFFFh
Bank15	BA8	32 Kwords	040000h-047FFFh
	BA7	32 Kwords	038000h-03FFFFh
	BA6	32 Kwords	030000h-037FFFh
	BA5	32 Kwords	028000h-02FFFFh
	BA4	32 Kwords	020000h-027FFFh
	BA3	32 Kwords	018000h-01FFFFh
	BA2	32 Kwords	010000h-017FFFh
	BA1	32 Kwords	008000h-00FFFFh
	BA0	32 Kwords	000000h-007FFFh

Table 3-1-1. OTP Block Addresses

OTP	Block Address A21 ~ A8	Block Size	(x16) Address Range
	7FFFh	128words	3FFF80h-3FFFFFh

After entering OTP block, any issued addresses should be in the range of OTP block address

Table 3-2. Bottom Boot Block Address (K8A6415EBB)

Bank	Block	Block Size	(x16) Address Range
Bank 15	BA134	32 Kwords	3F8000h-3FFFFFFh
	BA133	32 Kwords	3F0000h-3F7FFFh
	BA132	32 Kwords	3E8000h-3EFFFFh
	BA131	32 Kwords	3E0000h-3E7FFFh
	BA130	32 Kwords	3D8000h-3DFFFFh
	BA129	32 Kwords	3D0000h-3D7FFFh
	BA128	32 Kwords	3C8000h-3CFFFFh
Bank 14	BA127	32 Kwords	3C0000h-3C7FFFh
	BA126	32 Kwords	3B8000h-3BFFFFh
	BA125	32 Kwords	3B0000h-3B7FFFh
	BA124	32 Kwords	3A8000h-3AFFFFh
	BA123	32 Kwords	3A0000h-3A7FFFh
	BA122	32 Kwords	398000h-39FFFFh
	BA121	32 Kwords	390000h-397FFFh
Bank 13	BA120	32 Kwords	388000h-38FFFFh
	BA119	32 Kwords	380000h-387FFFh
	BA118	32 Kwords	378000h-37FFFFh
	BA117	32 Kwords	370000h-377FFFh
	BA116	32 Kwords	368000h-36FFFFh
	BA115	32 Kwords	360000h-367FFFh
	BA114	32 Kwords	358000h-35FFFFh
Bank 12	BA113	32 Kwords	350000h-357FFFh
	BA112	32 Kwords	348000h-34FFFFh
	BA111	32 Kwords	340000h-347FFFh
	BA110	32 Kwords	338000h-33FFFFh
	BA109	32 Kwords	330000h-337FFFh
	BA108	32 Kwords	328000h-32FFFFh
	BA107	32 Kwords	320000h-327FFFh
Bank 11	BA106	32 Kwords	318000h-31FFFFh
	BA105	32 Kwords	310000h-317FFFh
	BA104	32 Kwords	308000h-30FFFFh
	BA103	32 Kwords	300000h-307FFFh
	BA102	32 Kwords	2F8000h-2FFFFFFh
	BA101	32 Kwords	2F0000h-2F7FFFh
	BA100	32 Kwords	2E8000h-2EFFFFh
Bank 10	BA99	32 Kwords	2E0000h-2E7FFFh
	BA98	32 Kwords	2D8000h-2DFFFFh
	BA97	32 Kwords	2D0000h-2D7FFFh
	BA96	32 Kwords	2C8000h-2CFFFFh
Bank 10	BA95	32 Kwords	2C0000h-2C7FFFh
	BA94	32 Kwords	2B8000h-2BFFFFh
	BA93	32 Kwords	2B0000h-2B7FFFh
Bank 10	BA92	32 Kwords	2A8000h-2AFFFFh

Table 3-2. Bottom Boot Block Address (K8A6415EBB)

Bank	Block	Block Size	(x16) Address Range
Bank 10	BA91	32 Kwords	2A0000h-2A7FFFh
	BA90	32 Kwords	298000h-29FFFFh
	BA89	32 Kwords	290000h-297FFFh
	BA88	32 Kwords	288000h-28FFFFh
	BA87	32 Kwords	280000h-287FFFh
Bank 9	BA86	32 Kwords	278000h-27FFFFh
	BA85	32 Kwords	270000h-277FFFh
	BA84	32 Kwords	268000h-26FFFFh
	BA83	32 Kwords	260000h-267FFFh
	BA82	32 Kwords	258000h-25FFFFh
	BA81	32 Kwords	250000h-257FFFh
	BA80	32 Kwords	248000h-24FFFFh
	BA79	32 Kwords	240000h-247FFFh
Bank 8	BA78	32 Kwords	238000h-23FFFFh
	BA77	32 Kwords	230000h-237FFFh
	BA76	32 Kwords	228000h-22FFFFh
	BA75	32 Kwords	220000h-227FFFh
	BA74	32 Kwords	218000h-21FFFFh
	BA73	32 Kwords	210000h-217FFFh
	BA72	32 Kwords	208000h-20FFFFh
	BA71	32 Kwords	200000h-207FFFh
Bank 7	BA70	32 Kwords	1F8000h-1FFFFFh
	BA69	32 Kwords	1F0000h-1F7FFFh
	BA68	32 Kwords	1E8000h-1EFFFFh
	BA67	32 Kwords	1E0000h-1E7FFFh
	BA66	32 Kwords	1D8000h-1DFFFFh
	BA65	32 Kwords	1D0000h-1D7FFFh
	BA64	32 Kwords	1C8000h-1CFFFFh
	BA63	32 Kwords	1C0000h-1C7FFFh
Bank 6	BA62	32 Kwords	1B8000h-1BFFFFh
	BA61	32 Kwords	1B0000h-1B7FFFh
	BA60	32 Kwords	1A8000h-1AFFFFh
	BA59	32 Kwords	1A0000h-1A7FFFh
	BA58	32 Kwords	198000h-19FFFFh
	BA57	32 Kwords	190000h-197FFFh
	BA56	32 Kwords	188000h-18FFFFh
	BA55	32 Kwords	180000h-187FFFh
Bank 5	BA54	32 Kwords	178000h-17FFFFh
	BA53	32 Kwords	170000h-177FFFh
	BA52	32 Kwords	168000h-16FFFFh
	BA51	32 Kwords	160000h-167FFFh
	BA50	32 Kwords	158000h-15FFFFh
	BA49	32 Kwords	150000h-157FFFh
	BA48	32 Kwords	148000h-14FFFFh
	BA47	32 Kwords	140000h-147FFFh

Table 3-2. Bottom Boot Block Address (K8A6415EBB)

Bank	Block	Block Size	(x16) Address Range
Bank 4	BA46	32 Kwords	138000h-13FFFFh
	BA45	32 Kwords	130000h-137FFFh
	BA44	32 Kwords	128000h-12FFFFh
	BA43	32 Kwords	120000h-127FFFh
	BA42	32 Kwords	118000h-11FFFFh
	BA41	32 Kwords	110000h-117FFFh
	BA40	32 Kwords	108000h-10FFFFh
	BA39	32 Kwords	100000h-107FFFh
Bank 3	BA38	32 Kwords	0F8000h-0FFFFFh
	BA37	32 Kwords	0F0000h-0F7FFFh
	BA36	32 Kwords	0E8000h-0EFFFFh
	BA35	32 Kwords	0E0000h-0E7FFFh
	BA34	32 Kwords	0D8000h-0DFFFFh
	BA33	32 Kwords	0D0000h-0D7FFFh
	BA32	32 Kwords	0C8000h-0CFFFFh
	BA31	32 Kwords	0C0000h-0C7FFFh
Bank 2	BA30	32 Kwords	0B8000h-0BFFFFh
	BA29	32 Kwords	0B0000h-0B7FFFh
	BA28	32 Kwords	0A8000h-0AFFFFh
	BA27	32 Kwords	0A0000h-0A7FFFh
	BA26	32 Kwords	098000h-09FFFFh
	BA25	32 Kwords	090000h-097FFFh
	BA24	32 Kwords	088000h-08FFFFh
	BA23	32 Kwords	080000h-087FFFh
Bank 1	BA22	32 Kwords	078000h-07FFFFh
	BA21	32 Kwords	070000h-077FFFh
	BA20	32 Kwords	068000h-06FFFFh
	BA19	32 Kwords	060000h-067FFFh
	BA18	32 Kwords	058000h-05FFFFh
	BA17	32 Kwords	050000h-057FFFh
	BA16	32 Kwords	048000h-04FFFFh
	BA15	32 Kwords	040000h-047FFFh
Bank 0	BA14	32 Kwords	038000h-03FFFFh
	BA13	32 Kwords	030000h-037FFFh
	BA12	32 Kwords	028000h-02FFFFh
	BA11	32 Kwords	020000h-027FFFh
	BA10	32 Kwords	018000h-01FFFFh
	BA9	32 Kwords	010000h-017FFFh
	BA8	32 Kwords	008000h-00FFFFh
	BA7	4 Kwords	007000h-007FFFh
	BA6	4 Kwords	006000h-006FFFh
	BA5	4 Kwords	005000h-005FFFh
	BA4	4 Kwords	004000h-004FFFh
	BA3	4 Kwords	003000h-003FFFh
BA2	4 Kwords	002000h-002FFFh	
BA1	4 Kwords	001000h-001FFFh	
BA0	4 Kwords	000000h-000FFFh	

Table 3-2-2. OTP Block Addresses

OTP	Block Address A21 ~ A8	Block Size	(x16) Address Range
	0000h	128words	000000h-00007Fh

After entering OTP block, any issued addresses should be in the range of OTP block address

PRODUCT INTRODUCTION

The K8A6415E is an 64Mbit (67,108,364 bits) NOR-type Burst Flash memory. The device features 1.8V single voltage power supply operating within the range of 1.7V to 1.95V. The device is programmed by using the Channel Hot Electron (CHE) injection mechanism which is used to program EPROMs. The device is erased electrically by using Fowler-Nordheim tunneling mechanism. To provide highly flexible erase and program capability, the device adapts a block memory architecture that divides its memory array into 135 blocks (32-Kword x 127, 4-Kword x 8,). Programming is done in units of 16 bits (Word). All bits of data in one or multiple blocks can be erased when the device executes the erase operation. To prevent the device from accidental erasing or over-writing the programmed data, 135 memory blocks can be hardware protected. Regarding read access time, at 54MHz, the K8A6415E provides a burst access of 14.5ns with initial access times of 90ns at 30pF. At 66MHz, the K8A6415E provides a burst access of 11ns with initial access times of 70ns at 30pF. The command set of K8A6415E is compatible with standard Flash devices. The device uses Chip Enable (\overline{CE}), Write Enable (\overline{WE}), Address Valid(\overline{AVD}) and Output Enable (\overline{OE}) to control asynchronous read and write operation. For burst operations, the device additionally requires Ready (RDY) and Clock (CLK). Device operations are executed by selective command codes. The command codes to be combined with addresses and data are sequentially written to the command registers using microprocessor write timing. The command codes serve as inputs to an internal state machine which controls the program/erase circuitry. Register contents also internally latch addresses and data necessary to execute the program and erase operations. The K8A6415E is implemented with Internal Program/Erase Routines to execute the program/erase operations. The Internal Program/Erase Routines are invoked by program/erase command sequences. The Internal Program Routine automatically programs and verifies data at specified address. The Internal Erase Routine automatically pre-programs the memory cell which is not programmed and then executes the erase operation. The K8A6415E has means to indicate the status of completion of program/erase operations. The status can be indicated via Data polling of DQ7, or the Toggle bit (DQ6). Once the operations have been completed, the device automatically resets itself to the read mode. The device requires only 25 mA as burst and asynchronous mode read current and 15mA for program/erase operations.

Table 4. Device Bus Operations

Operation	\overline{CE}	\overline{OE}	\overline{WE}	A0-21	DQ0-15	\overline{RESET}	CLK	\overline{AVD}
Asynchronous Read Operation	L	L	H	Add In	I/O	H	L	L
Write	L	H		Add In	I/O	H	L	X
Standby	H	X	X	X	High-Z	H	X	X
Hardware Reset	X	X	X	X	High-Z	L	X	X
Load Initial Burst Address	L	H	H	Add In	X	H		
Burst Read Operation	L	L	H	X	Burst DOUT	H		H
Terminate Burst Read Cycle via \overline{CE}	H	X	X	X	High-Z	H	X	X
Terminate Burst Read Cycle via \overline{RESET}	X	X	X	X	High-Z	L	X	X
Terminate Current Burst Read Cycle and Start New Burst Read Cycle	L	H	H	Add In	I/O	H		

Note : L=V_{IL} (Low), H=V_{IH} (High), X=Don't Care.

COMMAND DEFINITIONS

The K8A6415E operates by selecting and executing its operational modes. Each operational mode has its own command set. In order to select a certain mode, a proper command with specific address and data sequences must be written into the command register. Writing incorrect information which include address and data or writing an improper command will reset the device to the read mode. The defined valid register command sequences are stated in Table 5.

Table 5. Command Sequences

Command Definitions		Cycle	1st Cycle	2nd Cycle	3rd Cycle	4th Cycle	5th Cycle	6th Cycle
Asynchronous Read	Add	1	RA					
	Data		RD					
Reset(Note 5)	Add	1	XXXH					
	Data		F0H					
Autoselect Manufacturer ID(Note 6)	Add	4	555H	2AAH	(DA)555H	(DA)X00H		
	Data		AAH	55H	90H	ECH		
Autoselect Device ID(Note 6)	Add	4	555H	2AAH	(DA)555H	(DA)X01H		
	Data		AAH	55H	90H	Note6		
Autoselect Block Protection Verify(Note 7)	Add	4	555H	2AAH	(BA)555H	(BA)X02H		
	Data		AAH	55H	90H	00H/01H		
Autoselect Handshaking(Note 6, 8)	Add	4	555H	2AAH	(DA)555H	(DA)X03H		
	Data		AAH	55H	90H	0H/1H		
Program	Add	4	555H	2AAH	555H	PA		
	Data		AAH	55H	A0H	PD		
Unlock Bypass	Add	3	555H	2AAH	555H			
	Data		AAH	55H	20H			
Unlock Bypass Program(Note 9)	Add	2	XXX	PA				
	Data		A0H	PD				
Unlock Bypass Block Erase(Note 9)	Add	2	XXX	BA				
	Data		80H	30H				
Unlock Bypass Chip Erase(Note 9)	Add	2	XXXH	XXXH				
	Data		80H	10H				
Unlock Bypass Reset	Add	2	XXXH	XXXH				
	Data		90H	00H				
Chip Erase	Add	6	555H	2AAH	555H	555H	2AAH	555H
	Data		AAH	55H	80H	AAH	55H	10H
Block Erase	Add	6	555H	2AAH	555H	555H	2AAH	BA
	Data		AAH	55H	80H	AAH	55H	30H
Erase Suspend (Note 10)	Add	1	(DA)XXXH					
	Data		B0H					
Erase Resume (Note 11)	Add	1	(DA)XXXH					
	Data		30H					
Program Suspend (Note12)	Add	1	(DA)XXXH					
	Data		B0H					
Program Resume (Note11)	Add	1	(DA)XXXH					
	Data		30H					

Table 5. Command Sequences (Continued)

Command Definitions		Cycle	1st Cycle	2nd Cycle	3rd Cycle	4th Cycle	5th Cycle	6th Cycle
Block Protection/Unprotection (Note 13)	Add	3	XXX	XXX	ABP			
	Data		60H	60H	60H			
CFI Query (Note 14)	Add	1	(DA)X55H					
	Data		98H					
Set Burst Mode Configuration Register (Note 15)	Add	3	555H	2AAH	(CR)555H			
	Data		AAH	55H	C0H			
Enter OTP Block Region	Addr	3	555H	2AAH	555H			
	Data		AAH	55H	70H			
Exit OTP Block Region	Addr	4	555H	2AAH	555H	XXX		
	Data		AAH	55H	75H	00H		

Notes:

1. RA : Read Address , PA : Program Address, RD : Read Data, PD : Program Data , BA : Block Address (A21 ~ A12)
DA : Bank Address (A21 ~ A18) , ABP : Address of the block to be protected or unprotected, CR : Configuration Register Setting
2. The 4th cycle data of autoselect mode and RD are output data. The others are input data.
3. Data bits DQ15–DQ8 are don't care in command sequences, except for RD, PD and Device ID.
4. Unless otherwise noted, address bits A21–A11 are don't cares.
5. The reset command is required to return to read mode.
If a bank entered the autoselect mode during the erase suspend mode, writing the reset command returns that bank to the erase suspend mode.
If a bank entered the autoselect mode during the program suspend mode, writing the reset command returns that bank to the program suspend mode.
If DQ5 goes high during the program or erase operation, writing the reset command returns that bank to read mode or erase suspend mode if that bank was in erase suspend mode.
6. The 3rd and 4th cycle bank address of autoselect mode must be same.
Device ID Data : 2252H" for Top Boot Block Device, "2253H" for Bottom Boot Block Device
7. 00H for an unprotected block and 01H for a protected block.
8. 0H for handshaking, 1H for non-handshaking
9. The unlock bypass command sequence is required prior to this command sequence.
10. The system may read and program in non-erasing blocks when in the erase suspend mode.
The system may enter the autoselect mode when in the erase suspend mode.
The erase suspend command is valid only during a block erase operation, and requires the bank address.
11. The erase/program resume command is valid only during the erase/program suspend mode, and requires the bank address.
12. This mode is used only to enable Data Read by suspending the Program operation.
13. Set block address(BA) as either A6 = V_{IH}, A1 = V_{IH} and A0 = V_{IL} for unprotected or A6 = V_{IL}, A1 = V_{IH} and A0 = V_{IL} for protected.
14. Command is valid when the device is in Read mode or Autoselect mode.
15. See "Set Burst Mode Congiguration Register" for details.

DEVICE OPERATION

To write a command or command sequence (which includes programming data to the device and erasing blocks of memory), the system must drive CLK, \overline{WE} and \overline{CE} to V_{IL} and \overline{OE} to V_{IH} when providing address or data. The device provides the unlock bypass mode to save its program time for program operation. Unlike the standard program command sequence which is comprised of four bus cycles, only two program cycles are required to program a word in the unlock bypass mode. One block, multiple blocks, or the entire device can be erased. Table 3 indicates the address space that each block occupies. The device's address space is divided into sixteen banks: Bank 0 contains the boot/parameter blocks, and the other banks (from Bank 1 to 15) consist of uniform blocks. A "bank address" is the address bits required to uniquely select a bank. Similarly, a "block address" is the address bits required to uniquely select a block. I_{CC2} in the DC Characteristics table represents the active current specification for the write mode. The AC Characteristics section contains timing specification tables and timing diagrams for write operations.

Read Mode

The device automatically enters to asynchronous read mode after device power-up. No commands are required to retrieve data in asynchronous mode. After completing an Internal Program/Erase Routine, each bank is ready to read array data. The reset command is required to return a bank to the read (or erase-suspend-read) mode if DQ5 goes high during an active program/erase operation, or if the bank is in the autoselect mode.

The synchronous (burst) mode will *automatically* be enabled on the first rising edge on the CLK input while \overline{AVD} is held low. That means device enters burst read mode from asynchronous read mode to burst read mode using CLK and \overline{AVD} signal. When the burst read is finished (or terminated), the device returns to asynchronous read mode automatically.

Asynchronous Read Mode

For the asynchronous read mode a valid address should be asserted on A0-A21, while driving \overline{AVD} and \overline{CE} to V_{IL} . \overline{WE} should remain at V_{IH} . The data will appear on DQ0-DQ15. Since the memory array is divided into sixteen banks, each bank remains enabled for read access until the command register contents are altered.

Address access time (t_{AA}) is equal to the delay from valid addresses to valid output data. The chip enable access time (t_{CE}) is the delay from the falling edge of \overline{CE} to valid data at the outputs. The output enable access time (t_{OE}) is the delay from the falling edge of \overline{OE} to valid data at the output. To prevent the memory content from spurious altering during power transition, the initial state machine is set for reading array data upon device power-up, or after a hardware reset.

Synchronous (Burst) Read Mode

The device is capable of continuous linear burst operation and linear burst operation of a preset length. For the burst mode, the system should determine how many clock cycles are desired for the initial word (t_{iACC}) of each burst access and what mode of burst operation is desired using "Burst Mode Configuration Register" command sequences. See "Set Burst Mode Configuration" for further details. The status data also can be read during burst read mode by using \overline{AVD} signal with a bank address. To initiate the synchronous read again, a new address and \overline{AVD} pulse is needed after the host has completed status reads or the device has completed the program or erase operation.

Continuous Linear Burst Read

The synchronous (burst) mode will *automatically* be enabled on the first rising edge on the CLK input while \overline{AVD} is held low. Note that the device is enabled for asynchronous mode when it first powers up. The initial word is output t_{iAA} after the rising edge of the first CLK cycle. Subsequent words are output t_{BA} after the rising edge of each successive clock cycle, which automatically increments the internal address counter. Note that the device has internal address boundary that occurs every 16 words. When the device is crossing the first word boundary, additional clock cycles are needed before data appears for the next address. The number of additional clock cycle can vary from zero to three cycles, and the exact number of additional clock cycle depends on the starting address of burst read. (Refer to Figure 17) The RDY output indicates this condition to the system by pulsing low. The device will continue to output sequential burst data, wrapping around to address 000000h after it reaches the highest addressable memory location until the system asserts \overline{CE} high, \overline{RESET} low or \overline{AVD} low in conjunction with a new address. (See Table 4.) The reset command does not terminate the burst read operation. When it accessed the bank is programming or erasing, continuous burst read mode will output status data. And status data will be sustained until the system asserts \overline{CE} high or \overline{RESET} low or \overline{AVD} low in conjunction with a new address.

Note that at least 10ns is needed to start next burst read operation from terminating previous burst read operation in the case of asserting \overline{CE} high.

8-,16-Word Linear Burst Read

As well as the Continuous Linear Burst Mode, there are two(8 & 16 word) linear wrap & no-wrap mode, in which a fixed number of words are read from consecutive addresses. In these modes, the addresses for burst read are determined by the group within which the starting address falls. The groups are sized according to the number of words read in a single burst sequence for a given mode.(See Table. 6)

Table 6. Burst Address Groups(Wrap mode only)

Burst Mode	Group Size	Group Address Ranges
8 word	8 words	0-7h, 8-Fh, 10-17h,
16 word	16 words	0-Fh, 10-1Fh, 20-2Fh,

As an example:

In wrap mode case, if the starting address in the 8-word mode is 2h, the address range to be read would be 0-7h, and the wrap burst sequence would be 2-3-4-5-6-7-0-1h. The burst sequence begins with the starting address written to the device, but wraps back to the first address in the selected group. In a similar manner, 16-word wrap mode begin their burst sequence on the starting address written to the device, and then wrap back to the first address in the selected address group.

In no-wrap mode case, if the starting address in the 8-word mode is 2h, the no-wrap burst sequence would be 2-3-4-5-6-7-8-9h. The burst sequence begins with the starting address written to the device, and continue to the 8th address from starting address. In a similar manner, 16-word no-wrap mode begin their burst sequence on the starting address written to the device, and continue to the 16th address from starting address. Also, when the address cross the word boundary in no-wrap mode, same number of additional clock cycles as continuous linear mode is needed.

Programmable Wait State

The programmable wait state feature indicates to the device the number of additional clock cycles that must elapse after \overline{AVD} is driven active for burst read mode. Upon power up, the number of total initial access cycles defaults to seven.

Handshaking

The handshaking feature allows the host system to simply monitor the RDY signal from the device to determine when the initial word of burst data is ready to be read. To set the number of initial cycle for optimal burst mode, the host should use the programmable wait state configuration.(See "Set Burst Mode Configuration Register" for details.) The rising edge of RDY after \overline{OE} goes low indicates the initial word of valid burst data. Using the autoselect command sequence the handshaking feature may be verified in the device.

Set Burst Mode Configuration Register

The device uses a configuration register to set the various burst parameters : the number of initial cycles for burst and burst read mode. The burst mode configuration register must be set before the device enter burst mode.

The burst mode configuration register is loaded with a three-cycle command sequences. On the third cycle, the data should be C0h, address bits A11-A0 should be 555h, and address bits A18-A12 set the code to be latched. The device will power up or after a hardware reset with the default setting.

Table 7. Burst Mode Configuration Register Table

Address Bit	Function	Settings(Binary)
A18	RDY Active	1 = RDY active one clock cycle before data 0 = RDY active with data(default)
A17	Burst Read Mode	000 = Continuous(default) 001 = 8-word linear with wrap 010 = 16-word linear with wrap 011 = 8-word linear with no-wrap 100 = 16-word linear with no-wrap 101 ~ 111 = Reserve
A16		
A15		
A14	Programmable Wait State	000 = Data is valid on the 4th active CLK edge after AVD transition to V_{IH} 001 = Data is valid on the 5th active CLK edge after AVD transition to V_{IH} 010 = Data is valid on the 6th active CLK edge after AVD transition to V_{IH} 011 = Data is valid on the 7th active CLK edge after AVD transition to V_{IH} (default) 100 = Reserve 101 = Reserve 110 = Reserve 111 = Reserve
A13		
A12		

Programmable Wait State Configuration

This feature informs the device of the number of clock cycles that must elapse after AVD# is driven active before data will be available. This value is determined by the input frequency of the device. Address bits A14-A12 determine the setting. (See Burst Mode Configuration Register Table)

The Programmable wait state setting instructs the device to set a particular number of clock cycles for the initial access in burst mode. Note that hardware reset will set the wait state to the default setting, that is 7 initial cycles.

Burst Read Mode Setting

The device supports five different burst read modes : continuous linear mode, 8 and 16 word linear burst modes with wrap and 8 and 16 word linear burst modes with no-wrap.

RDY Configuration

By default, the RDY pin will be high whenever there is valid data on the output. The device can be set so that RDY goes active one data cycle before active data. Address bit A18 determine this setting. Note that RDY always go high with valid data in case of word boundary crossing.

Table 8. Burst Address Sequences

	Start Addr.	Burst Address Sequence(Decimal)		
		Continuous Burst	8-word Burst	16-word Burst
Wrap	0	0-1-2-3-4-5-6...	0-1-2-3-4-5-6-7	0-1-2-3 ... -D-E-F
	1	1-2-3-4-5-6-7...	1-2-3-4-5-6-7-0	1-2-3-4 ... -E-F-0
	2	2-3-4-5-6-7-8...	2-3-4-5-6-7-0-1	2-3-4-5 ... -F-0-1

No-wrap	0	0-1-2-3-4-5-6...	0-1-2-3-4-5-6-7	0-1-2-3 ... -D-E-F
	1	1-2-3-4-5-6-7...	1-2-3-4-5-6-7-8	1-2-3-4 ... -E-F-10
	2	2-3-4-5-6-7-8...	2-3-4-5-6-7-8-9	2-3-4-5 ... -F-10-11

Autoselect Mode

By writing the autoselect command sequences to the system, the device enters the autoselect mode. This mode can be read only by asynchronous read mode. The system can then read autoselect codes from the internal register(which is separate from the memory array). Standard asynchronous read cycle timings apply in this mode. The device offers the Autoselect mode to identify manufacturer and device type by reading a binary code. In addition, this mode allows the host system to verify the block protection or unprotection. Table 5 shows the address and data requirements. The autoselect command sequence may be written to an address within a bank that is in the read mode, erase-suspend-read mode or program-suspend-read mode. The autoselect command may not be written while the device is actively programming or erasing in the device. The autoselect command sequence is initiated by first writing two unlock cycles. This is followed by a third write cycle that contains the address and the autoselect command. Note that the block address is needed for the verification of block protection. The system may read at any address within the same bank any number of times without initiating another autoselect command sequence. And the burst read should be prohibited during Autoselect Mode. To terminate the autoselect operation, write Reset command(F0H) into the command register.

Table 9. Autoselect Mode Description

Description	Address	Read Data
Manufacturer ID	(DA) + 00H	ECH
Device ID	(DA) + 01H	2252H(Top Boot Block), 2253H(Bottom Boot Block)
Block Protection/Unprotection	(BA) + 02H	01H (protected), 00H (unprotected)
Handshaking	(DA) + 03H	0H : Handshaking, 1H : Non-Handshaking

Standby Mode

When the \overline{CE} and \overline{RESET} inputs are both held at $V_{cc} \pm 0.2V$ or the system is not reading or writing, the device enters Stand-by mode to minimize the power consumption. In this mode, the device outputs are placed in the high impedance state, independent of the \overline{OE} input. When the device is in either of these standby modes, the device requires standard access time (t_{CE}) for read access before it is ready to read data. If the device is deselected during erasure or programming, the device draws active current until the operation is completed. I_{CC5} in the DC Characteristics table represents the standby current specification.

Automatic Sleep Mode

The device features Automatic Sleep Mode to minimize the device power consumption during both asynchronous and burst mode. When addresses remain stable for $t_{AA}+60ns$, the device automatically enables this mode. The automatic sleep mode is independent of the \overline{CE} , \overline{WE} , and \overline{OE} control signals. In a sleep mode, output data is latched and always available to the system. When addresses are changed, the device provides new data without wait time. Automatic sleep mode current is equal to standby mode current.

Output Disable Mode

When the \overline{OE} input is at V_{IH} , output from the device is disabled. The outputs are placed in the high impedance state.

Block Protection & Unprotection

To protect the block from accidental writes, the block protection/unprotection command sequence is used. On power up, all blocks in the device are protected. To unprotect a block, the system must write the block protection/unprotection command sequence. The first two cycles are written: addresses are don't care and data is 60h. Using the third cycle, the block address (ABP) and command (60h) is written, while specifying with addresses A6, A1 and A0 whether that block should be protected (A6 = V_{IL} , A1 = V_{IH} , A0 = V_{IL}) or unprotected (A6 = V_{IH} , A1 = V_{IH} , A0 = V_{IL}). After the third cycle, the system can continue to protect or unprotect additional cycles, or exit the sequence by writing F0h (reset command).

The device offers three types of data protection at the block level:

- The block protection/unprotection command sequence disables or re-enables both program and erase operations in any block.
- When \overline{WP} is at V_{IL} , the two outermost blocks are protected.
- When V_{PP} is at V_{IL} , all blocks are protected.

Note that user never float the V_{pp} and \overline{WP} , that is, V_{pp} is always connected with V_{IH} , V_{IL} or V_{ID} and \overline{WP} is V_{IH} or V_{IL} .

Hardware Reset

The device features a hardware method of resetting the device by the \overline{RESET} input. When the \overline{RESET} pin is held low (V_{IL}) for at least a period of t_{RP} , the device immediately terminates any operation in progress, tristates all outputs, and ignores all read/write commands for the duration of the \overline{RESET} pulse. The device also resets the internal state machine to asynchronous read mode. To ensure data integrity, the interrupted operation should be reinitiated once the device is ready to accept another command sequence. As previously noted, when \overline{RESET} is held at $V_{SS} \pm 0.2V$, the device enters standby mode. The \overline{RESET} pin may be tied to the system reset pin. If a system reset occurs during the Internal Program or Erase Routine, the device will be automatically reset to the asynchronous read mode; this will enable the systems microprocessor to read the boot-up firmware from the Flash memory. If \overline{RESET} is asserted during a program or erase operation, the device requires a time of t_{READY} (during Internal Routines) before the device is ready to read data again. If \overline{RESET} is asserted when a program or erase operation is not executing, the reset operation is completed within a time of t_{READY} (not during Internal Routines). t_{RH} is needed to read data after \overline{RESET} returns to V_{IH} . Refer to the AC Characteristics tables for \overline{RESET} parameters and to Figure 6 for the timing diagram.

Software Reset

The reset command provides that the bank is reset to read mode, erase-suspend-read mode or program-suspend-read mode. The addresses are in Don't Care state. The reset command may be written between the sequence cycles in an erase command sequence before erasing begins, or in an program command sequence before programming begins. If the device begins erasure or programming, the reset command is ignored until the operation is completed. If the program command sequence is written to a bank that is in the Erase Suspend mode, writing the reset command returns that bank to the erase-suspend-read mode. The reset command valid between the sequence cycles in an autoselect command sequence. In an autoselect mode, the reset command must be written to return to the read mode. If a bank entered the autoselect mode while in the Erase Suspend mode, writing the reset command returns that bank to the erase-suspend-read mode. Also, if a bank entered the autoselect mode while in the Program Suspend mode, writing the reset command returns that bank to the program-suspend-read mode. If DQ5 goes high during a program or erase operation, writing the reset command returns the banks to the read mode. (or erase-suspend-read mode if the bank was in Erase Suspend)

Program

The K8A6415E can be programmed in units of a word. Programming is writing 0's into the memory array by executing the Internal Program Routine. In order to perform the Internal Program Routine, a four-cycle command sequence is necessary. The first two cycles are unlock cycles. The third cycle is assigned for the program setup command. In the last cycle, the address of the memory location and the data to be programmed at that location are written. The device automatically generates adequate program pulses and verifies the programmed cell margin by the Internal Program Routine. During the execution of the Routine, the system is not required to provide further controls or timings. During the Internal Program Routine, commands written to the device will be ignored. Note that a hardware reset during a program operation will cause data corruption at the corresponding location.

Accelerated Program Operation

The device provides Single/Quadruple word accelerated program operations through the V_{pp} input. Using this mode, faster manufacturing throughput at the factory is possible. When V_{ID} is asserted on the V_{pp} input, the device automatically enters the Unlock Bypass mode, temporarily unprotects any protected blocks, and uses the higher voltage on the input to reduce the time required for program operations. By removing V_{ID} returns the device to normal operation mode.

Note that Read while Accelerated Program and Program suspend mode are not guaranteed

Single word accelerated program operation

The system would use two-cycle program sequence (One-cycle (XXX - A0H) is for single word program command, and Next one-cycle (PA - PD) is for program address and data).

Quadruple word accelerated program operation

As well as Single word accelerated program, the system would use five-cycle program sequence (One-cycle (XXX - A5H) is for quadruple word program command, and four cycles are for program address and data).

- Only four words programming is possible
- Each program address must have the same A21~A2 address
- The device automatically generates adequate program pulses and ignores other command after program command
- Program/Erase cycling must be limited below 100cycles for optimum performance.

- Read while Write mode is not guaranteed

Requirements : Ambient temperature : TA=30°C±10°C

Unlock Bypass

The K8A6415E provides the unlock bypass mode to save its operation time. This mode is possible for program, block erase and chip erase operation. There are two methods to enter the unlock bypass mode. The mode is invoked by the unlock bypass command sequence or the assertion of VID on VPP pin. Unlike the standard program/erase command sequence that contains four bus cycles, the unlock bypass program/erase command sequence comprises only two bus cycles. The unlock bypass mode is engaged by issuing the unlock bypass command sequence which is comprised of three bus cycles. Writing first two unlock cycles is followed by a third cycle containing the unlock bypass command (20H). Once the device is in the unlock bypass mode, the unlock bypass program/erase command sequence is necessary. The unlock bypass program command sequence is comprised of only two bus cycles; writing the unlock bypass program command (A0H) is followed by the program address and data. This command sequence is the only valid one for programming the device in the unlock bypass mode. Also, The unlock bypass erase command sequence is comprised of two bus cycles; writing the unlock bypass block erase command(80H-30H) or writing the unlock bypass chip erase command(80H-10H). This command sequences are the only valid ones for erasing the device in the unlock bypass mode. The unlock bypass reset command sequence is the only valid command sequence to exit the unlock bypass mode. The unlock bypass reset command sequence consists of two bus cycles. The first cycle must contain the data (90H). The second cycle contains only the data (00H). Then, the device returns to the read mode.

To enter the unlock bypass mode in hardware level, the VID also can be used. By assertion VID on the VPP pin, the device enters the unlock bypass mode. Also, the all blocks are temporarily unprotected when the device using the VID for unlock bypass mode. To exit the unlock bypass mode, just remove the asserted VID from the VPP pin.(Note that user never float the Vpp, that is, Vpp is always connected with VIH, VIL or VID.).

Chip Erase

To erase a chip is to write 1's into the entire memory array by executing the Internal Erase Routine. The Chip Erase requires six bus cycles to write the command sequence. The erase set-up command is written after first two "unlock" cycles. Then, there are two more write cycles prior to writing the chip erase command. The Internal Erase Routine automatically pre-programs and verifies the entire memory for an all zero data pattern prior to erasing. The automatic erase begins on the rising edge of the last WE pulse in the command sequence and terminates when DQ7 is "1". After that the device returns to the read mode.

Block Erase

To erase a block is to write 1's into the desired memory block by executing the Internal Erase Routine. The Block Erase requires six bus cycles to write the command sequence shown in Table 5. After the first two "unlock" cycles, the erase setup command (80H) is written at the third cycle. Then there are two more "unlock" cycles followed by the Block Erase command. The Internal Erase Routine automatically pre-programs and verifies the entire memory prior to erasing it. The block address is latched on the rising edge of AVD, while the Block Erase command is latched on the rising edge of WE. Multiple blocks can be erased sequentially by writing the sixth bus-cycle. Upon completion of the last cycle for the Block Erase, additional block address and the Block Erase command (30H) can be written to perform the Multi-Block Erase. For the Multi-Block Erase, only sixth cycle(block address and 30H) is needed.(Similarly, only second cycle is needed in unlock bypass block erase.) An 50us (typical) "time window" is required between the Block Erase command writes. The Block Erase command must be written within the 50us "time window", otherwise the Block Erase command will be ignored. The 50us "time window" is reset when the falling edge of the WE occurs within the 50us of "time window" to latch the Block Erase command. During the 50us of "time window", any command other than the Block Erase or the Erase Suspend command written to the device will reset the device to read mode. After the 50 us of "time window", the Block Erase command will initiate the Internal Erase Routine to erase the selected blocks. Any Block Erase address and command following the exceeded "time window" may or may not be accepted. No other commands will be recognized except the Erase Suspend command during Block Erase operation.

The device provides accelerated erase operations through the Vpp input. When VID is asserted on the Vpp input, the device automatically enters the Unlock Bypass mode, temporarily unprotects any protected blocks, and uses the higher voltage on the input to reduce the time required for erase. By removing VID returns the device to normal operation mode.

Erase Suspend / Resume

The Erase Suspend command interrupts the Block Erase to read or program data in a block that is not being erased. Also, it is possible to protect or unprotect of the block that is not being erased in erase suspend mode. The Erase Suspend command is only valid during the Block Erase operation including the time window of 50 us. The Erase Suspend command is not valid while the Chip Erase or the Internal Program Routine sequence is running. When the Erase Suspend command is written during a Block Erase operation, the device requires a maximum of 20 us(recovery time) to suspend the erase operation. Therefore system must wait for 20us(recovery time) to read the data from the bank which include the block being erased. Otherwise, system can read the data immediately from a bank which don't include the block being erased without recovery time(max. 20us) after Erase Suspend command. And, after the maximum 20us recovery time, the device is available for programming data in a block that is not being erased. But, when the Erase Suspend command is written during the block erase time window (50 us) , the device immediately terminates the block erase time window and suspends the erase operation. The system may also write the autoselect command sequence when the device is in the Erase Suspend mode. When the Erase Resume command is executed, the Block Erase operation will resume. When the Erase Suspend or Erase Resume command is executed, the addresses are in Don't Care state.

Program Suspend / Resume

The device provides the Program Suspend/Resume mode. This mode is used to enable Data Read by suspending the Program operation. The device accepts a Program Suspend command in Program mode(including Program operations performed during Erase Suspend) but other commands are ignored. After input of the Program Suspend command, 2us is needed to enter the Program Suspend Read mode. Therefore system must wait for 2us(recovery time) to read the data from the bank which include the block being programmed. Otherwise, system can read the data immediately from a bank which don't include block being programmed without recovery time(max. 2us) after Program Suspend command. Like an Erase Suspend mode, the device can be returned to Program mode by using a Program Resume command.

Read While Write Operation

The device is capable of reading data from one bank while writing in the other banks. This is so called the Read While Write operation. An erase operation may also be suspended to read from or program to another location within the same bank(except the block being erased). The Read While Write operation is prohibited during the chip erase operation. Figure 12 shows how read and write cycles may be initiated for simultaneous operation with zero latency. Refer to the DC Characteristics table for read-while-write current specifications.

OTP Block Region

The OTP Block feature provides a 256-byte Flash memory region that enables permanent part identification through an Electronic Serial Number (ESN). The OTP Block is customer lockable and shipped with itself unlocked, allowing customers to utilize the that block in any manner they choose. The customer-lockable OTP Block has the Protection Verify Bit (DQ0) set to a "0" for Unlocked state or a "1" for Locked state.

The system accesses the OTP Block through a command sequence (see "Enter OTP Block / Exit OTP Block Command sequence" at Table8). After the system has written the "Enter OTP Block" Command sequence, it may read the OTP Block by using the addresses (7FFF80h~7FFFFh) normally and may check the Protection Verify Bit (DQ0) by using the "Autoselect Block Protection Verify" Command sequence with OTP Block address. This mode of operation continues until the system issues the "Exit OTP Block" Command sequence, a hardware reset or until power is removed from the device. On power-up, or following a hardware reset, the device reverts to sending commands to main blocks. Note that the Accelerated function and unlock bypass modes are not available when the OTP Block is enabled.

Customer Lockable

In a Customer lockable device, The OTP Block is one-time programmable and can be locked only once. Note that the Accelerated programming and Unlock bypass functions are not available when programming the OTP Block. Locking operation to the OTP Block is started by writing the "Enter OTP Block" Command sequence, and then the "Block Protection" Command sequence (Table 8) with an OTP Block address. Hardware reset terminates Locking operation, and then makes exiting from OTP Block. The Locking operation has to be above 100us.

The OTP Block Lock operation must be used with caution since, once locked, there is no procedure available for unlocking and none of the bits in the OTP Block space can be modified in any way.

Write Pulse "Glitch" Protection

Noise pulses of less than 5ns (typical) on \overline{OE} , \overline{CE} , \overline{AVD} or \overline{WE} do not initiate a write cycle.

Low Vcc Write Inhibit

To avoid initiation of a write cycle during Vcc power-up and power-down, a write cycle is locked out for Vcc less than VLKO. If the Vcc < VLKO (Lock-Out Voltage), the command register and all internal program/erase circuits are disabled. Under this condition the device will reset itself to the read mode. Subsequent writes will be ignored until the Vcc level is greater than VLKO. It is the user's responsibility to ensure that the control pins are logically correct to prevent unintentional writes when Vcc is above VLKO.

Logical Inhibit

Write cycles are inhibited by holding any one of $\overline{OE} = V_{IL}$, $\overline{CE} = V_{IH}$ or $\overline{WE} = V_{IH}$. To initiate a write cycle, \overline{CE} and \overline{WE} must be a logical zero while \overline{OE} is a logical one.

Power-up Protection

To avoid initiation of a write cycle during Vcc power-up, \overline{RESET} low must be asserted during Power-up. After \overline{RESET} goes high, the device is reset to the read mode.

FLASH MEMORY STATUS FLAGS

The K8A6415E has means to indicate its status of operation in the bank where a program or erase operation is in processes. Address must include bank address being executed internal routine operation. The status is indicated by raising the device status flag via corresponding DQ pins. The status data can be read during burst read mode by using \overline{AVD} signal with a bank address. That means status read is supported in synchronous mode. If status read is performed, the data provided in the burst read is identical to the data in the initial access. To initiate the synchronous read again, a new address and \overline{AVD} pulse is needed after the host has completed status reads or the device has completed the program or erase operation. The corresponding DQ pins are DQ7, DQ6, DQ5, DQ3 and DQ2.

Table 10. Hardware Sequence Flags

		Status	DQ7	DQ6	DQ5	DQ3	DQ2
In Progress	Programming		$\overline{DQ7}$	Toggle	0	0	1
	Block Erase or Chip Erase		0	Toggle	0	1	Toggle
	Erase Suspend Read	Erase Suspended Block	1	1	0	0	Toggle (Note 1)
	Erase Suspend Read	Non-Erase Suspended Block	Data	Data	Data	Data	Data
	Erase Suspend Program	Non-Erase Suspended Block	$\overline{DQ7}$	Toggle	0	0	1
	Program Suspend Read	Program Suspended Block	DQ7	1	0	0	Toggle (Note 1)
	Program Suspend Read	Non-program Suspended Block	Data	Data	Data	Data	Data
Exceeded Time Limits	Programming		$\overline{DQ7}$	Toggle	1	0	No Toggle
	Block Erase or Chip Erase		0	Toggle	1	1	(Note 2)
	Erase Suspend Program		$\overline{DQ7}$	Toggle	1	0	No Toggle

Notes :

1. DQ2 will toggle when the device performs successive read operations from the erase/program suspended block.
2. If DQ5 is High (exceeded timing limits), successive reads from a problem block will cause DQ2 to toggle.

DQ7 : Data Polling

When an attempt to read the device is made while executing the Internal Program, the complement of the data is written to DQ7 as an indication of the Routine in progress. When the Routine is completed an attempt to access to the device will produce the true data written to DQ7. When a user attempts to read the block being erased, DQ7 will be low. If the device is placed in the Erase/Program Suspend Mode, the status can be detected via the DQ7 pin. If the system tries to read an address which belongs to a block that is being erase suspended, DQ7 will be high. And, if the system tries to read an address which belongs to a block that is being program suspended, the output will be the true data of DQ7 itself. If a non-erase-suspended or non-program-suspended block address is read, the device will produce the true data to DQ7. If an attempt is made to program a protected block, DQ7 outputs complements the data for approximately 1μs and the device then returns to the Read Mode without changing data in the block. If an attempt is made to erase a protected block, DQ7 outputs complement data in approximately 100us and the device then returns to the Read Mode without erasing the data in the block.

DQ6 : Toggle Bit

Toggle bit is another option to detect whether an Internal Routine is in progress or completed. Once the device is at a busy state, DQ6 will toggle. Toggling DQ6 will stop after the device completes its Internal Routine. If the device is in the Erase/Program Suspend Mode, an attempt to read an address that belongs to a block that is being erased or programmed will produce a high output of DQ6. If an address belongs to a block that is not being erased or programmed, toggling is halted and valid data is produced at DQ6. If an attempt is made to program a protected block, DQ6 toggles for approximately 1us and the device then returns to the Read Mode without changing the data in the block. If an attempt is made to erase a protected block, DQ6 toggles for approximately 100μs and the device then returns to the Read Mode without erasing the data in the block.

DQ5 : Exceed Timing Limits

If the Internal Program/Erase Routine extends beyond the timing limits, DQ5 will go High, indicating program/erase failure.

DQ3 : Block Erase Timer

The status of the multi-block erase operation can be detected via the DQ3 pin. DQ3 will go High if 50μs of the block erase time window expires. In this case, the Internal Erase Routine will initiate the erase operation. Therefore, the device will not accept further write commands until the erase operation is completed. DQ3 is Low if the block erase time window is not expired. Within the block erase time window, an additional block erase command (30H) can be accepted. To confirm that the block erase command has been accepted, the software may check the status of DQ3 following each block erase command.

DQ2 : Toggle Bit 2

The device generates a toggling pulse in DQ2 only if an Internal Erase Routine or an Erase/Program Suspend is in progress. When the device executes the Internal Erase Routine, DQ2 toggles only if an erasing block is read. Although the Internal Erase Routine is in the Exceeded Time Limits, DQ2 toggles only if an erasing block in the Exceeded Time Limits is read. When the device is in the Erase/Program Suspend mode, DQ2 toggles only if an address in the erasing or programming block is read. If a non-erasing or non-programmed block address is read during the Erase/Program Suspend mode, then DQ2 will produce valid data. DQ2 will go High if the user tries to program a non-erase suspend block while the device is in the Erase Suspend mode.

RDY: Ready

Normally the RDY signal is used to indicate if new burst data is available at the rising edge of the clock cycle or not. If RDY is low state, data is not valid at expected time, and if high state, data is valid. Note that, if \overline{CE} is low and \overline{OE} is high, the RDY is high state.

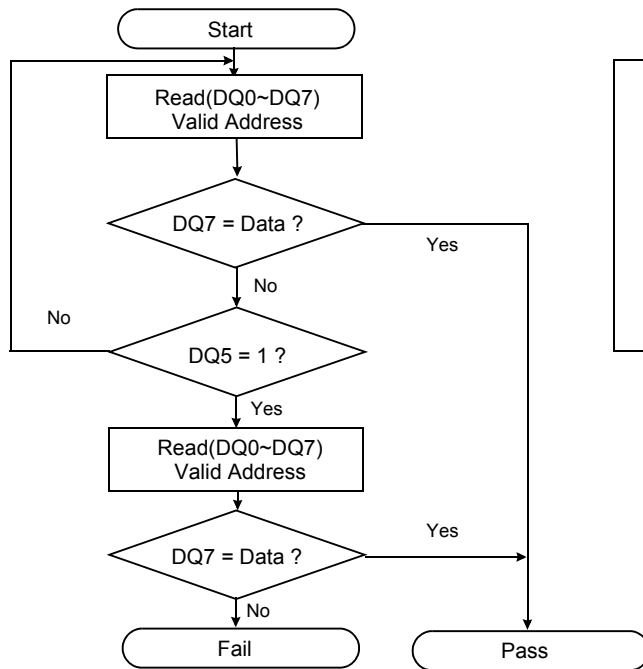

Figure 1. Data Polling Algorithms

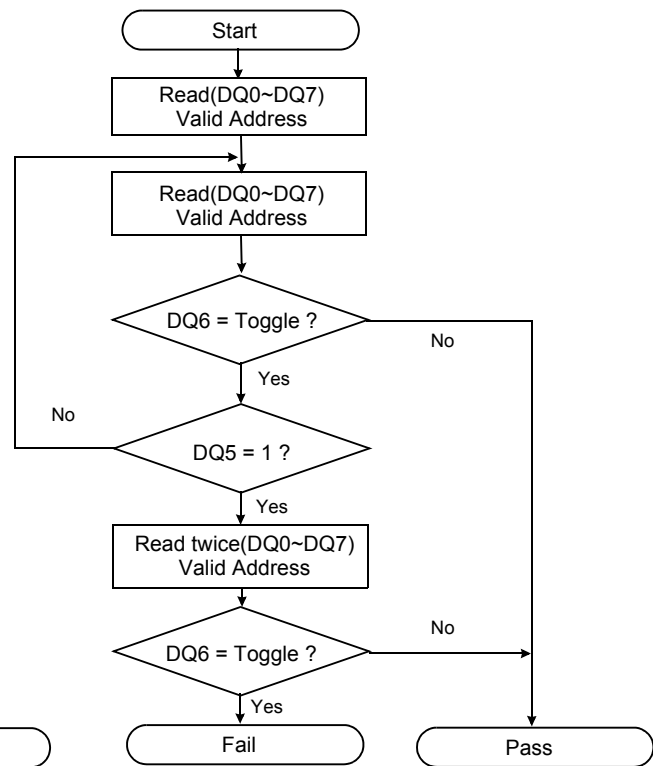

Figure 2. Toggle Bit Algorithms

Common Flash Memory Interface

Common Flash Memory Interface is contrived to increase the compatibility of host system software. It provides the specific information of the device, such as memory size and electrical features. Once this information has been obtained, the system software will know which command sets to use to enable flash writes, block erases, and control the flash component.

When the system writes the CFI command(98H) to address 55H, the device enters the CFI mode. And then if the system writes the address shown in Table 11, the system can read the CFI data. Query data are always presented on the lowest-order data outputs(DQ0-7) only. In word(x16) mode, the upper data outputs(DQ8-15) is 00h. To terminate this operation, the system must write the reset command.

Table 11. Common Flash Memory Interface Code

Description	Addresses (Word Mode)	Data
Query Unique ASCII string "QRY"	10H 11H 12H	0051H 0052H 0059H
Primary OEM Command Set	13H 14H	0002H 0000H
Address for Primary Extended Table	15H 16H	0040H 0000H
Alternate OEM Command Set (00h = none exists)	17H 18H	0000H 0000H
Address for Alternate OEM Extended Table (00h = none exists)	19H 1AH	0000H 0000H
Vcc Min. (write/erase) D7-D4: volt, D3-D0: 100 millivolt	1BH	0017H
Vcc Max. (write/erase) D7-D4: volt, D3-D0: 100 millivolt	1CH	0019H
Vpp(Acceleration Program) Supply Minimum 00 = Not Supported, D7 - D4 : Volt, D3 - D0 : 100mV	1DH	0085H
Vpp(Acceleration Program) Supply Maximum 00 = Not Supported, D7 - D4 : Volt, D3 - D0 : 100mV	1EH	0095H
Typical timeout per single word write 2^N us	1FH	0004H
Typical timeout for Min. size buffer write 2^N us(00H = not supported)	20H	0000H
Typical timeout per individual block erase 2^N ms	21H	000AH
Typical timeout for full chip erase 2^N ms(00H = not supported)	22H	0011H
Max. timeout for word write 2^N times typical	23H	0005H
Max. timeout for buffer write 2^N times typical	24H	0000H
Max. timeout per individual block erase 2^N times typical	25H	0004H
Max. timeout for full chip erase 2^N times typical(00H = not supported)	26H	0000H
Device Size = 2^N byte	27H	0017H
Flash Device Interface description	28H 29H	0000H 0000H
Max. number of byte in multi-byte write = 2^N	2AH 2BH	0000H 0000H
Number of Erase Block Regions within device	2CH	0002H

Table 11. Common Flash Memory Interface Code (Continued)

Description	Addresses (Word Mode)	Data
Erase Block Region 1 Information Bits 0~15: y+1=block number Bits 16~31: block size= z x 256bytes	2DH 2EH 2FH 30H	0007H 0000H 0020H 0000H
Erase Block Region 2 Information	31H 32H 33H 34H	007EH 0000H 0000H 0001H
Erase Block Region 3 Information	35H 36H 37H 38H	0000H 0000H 0000H 0000H
Erase Block Region 4 Information	39H 3AH 3BH 3CH	0000H 0000H 0000H 0000H
Query-unique ASCII string "PRI"	40H 41H 42H	0050H 0052H 0049H
Major version number, ASCII	43H	0032H
Minor version number, ASCII	44H	0030H
Address Sensitive Unlock(Bits 1-0) 0 = Required, 1= Not Required Silcon Revision Number(Bits 7-2)	45H	0000H
Erase Suspend 0 = Not Supported, 1 = To Read Only, 2 = To Read & Write	46H	0002H
Block Protect 00 = Not Supported, 01 = Supported	47H	0001H
Block Temporary Unprotect 00 = Not Supported, 01 = Supported	48H	0000H
Block Protect/Unprotect scheme 00 = Not Supported, 01 = Supported	49H	0001H
Simultaneous Operation 00 = Not Supported, 01 = Supported	4AH	0001H
Burst Mode Type 00 = Not Supported, 01 = Supported	4BH	0001H
Page Mode Type 00 = Not Supported, 01 = 4 Word Page 02 = 8 Word Page	4CH	0000H
Max. Operating Clock Frequency (MHz)	4EH	0042H
RWW(Read While Write) Functionality Restriction (00H = non exists , 01H = exists)	4FH	0000H
Handshaking 00 = Not Supported at both mode, 01 = Supported at Sync. Mode 10 = Supported at Async. Mode, 11 = Supported at both Mode	50H	0001H

ABSOLUTE MAXIMUM RATINGS

Parameter	Symbol	Rating	Unit	
Voltage on any pin relative to V _{SS}	V _{CC}	V _{CC}	-0.5 to +2.5	V
	V _{PP}	V _{IN}	-0.5 to +9.5	
	All Other Pins		-0.5 to +2.5	
Temperature Under Bias	Commercial	T _{bias}	-10 to +125	°C
	Extended		-25 to +125	
Storage Temperature	T _{stg}	-65 to +150	°C	
Short Circuit Output Current	I _{OS}	5	mA	
Operating Temperature	T _A (Commercial Temp.)	0 to +70	°C	
	T _A (Extended Temp.)	-25 to +85	°C	

Notes :

- Minimum DC voltage is -0.5V on Input/ Output pins. During transitions, this level may fall to -2.0V for periods <20ns.
Maximum DC voltage is V_{CC}+0.6V on input / output pins which, during transitions, may overshoot to V_{CC}+2.0V for periods <20ns.
- Minimum DC input voltage is -0.5V on V_{PP}. During transitions, this level may fall to -2.0V for periods <20ns.
Maximum DC input voltage is +9.5V on V_{PP} which, during transitions, may overshoot to +12.0V for periods <20ns.
- Permanent device damage may occur if ABSOLUTE MAXIMUM RATINGS are exceeded. Functional operation should be restricted to the conditions detailed in the operational sections of this data sheet. Exposure to absolute maximum rating conditions for extended periods may affect reliability.

RECOMMENDED OPERATING CONDITIONS (Voltage reference to GND)

Parameter	Symbol	Min	Typ.	Max	Unit
Supply Voltage	V _{CC}	1.7	1.8	1.95	V
Supply Voltage	V _{SS}	0	0	0	V

DC CHARACTERISTICS

Parameter	Symbol	Test Conditions	Min	Typ	Max	Unit	
Input Leakage Current	I _{LI}	V _{IN} =V _{SS} to V _{CC} , V _{CC} =V _{CCmax}	-1.0	-	+1.0	μA	
V _{PP} Leakage Current	I _{LIP}	V _{CC} =V _{CCmax} , V _{PP} =9.5V	-	-	35	μA	
Output Leakage Current	I _{LO}	V _{OUT} =V _{SS} to V _{CC} , V _{CC} =V _{CCmax} , \overline{OE} =V _{IH}	-1.0	-	+1.0	μA	
Active Burst Read Current	I _{CCB1}	\overline{CE} =V _{IL} , \overline{OE} =V _{IH} (Continuous Burst, 66MHz)	-	24	36	mA	
Active Asynchronous Read Current	I _{CC1}	\overline{CE} =V _{IL} , \overline{OE} =V _{IH}	10MHz	-	27	40	mA
			1MHz	-	3	5	mA
Active Write Current (Note 2)	I _{CC2}	\overline{CE} =V _{IL} , \overline{OE} =V _{IH} , \overline{WE} =V _{IL} , V _{PP} =V _{IH}	-	15	30	mA	
Read While Write Current	I _{CC3}	\overline{CE} =V _{IL} , \overline{OE} =V _{IH}	-	40	70	mA	
Accelerated Program Current	I _{CC4}	\overline{CE} =V _{IL} , \overline{OE} =V _{IH} , V _{PP} =9.5V	-	15	30	mA	
Standby Current	I _{CC5}	\overline{CE} = \overline{RESET} =V _{CC} ± 0.2V	-	15	50	μA	
Standby Current During Reset	I _{CC6}	\overline{RESET} = V _{SS} ± 0.2V	-	15	50	μA	
Automatic Sleep Mode(Note 3)	I _{CC7}	\overline{CE} =V _{SS} ± 0.2V, Other Pins=V _{IL} or V _{IH} V _{IL} = V _{SS} ± 0.2V, V _{IH} = V _{CC} ± 0.2V	-	15	50	μA	
Input Low Voltage	V _{IL}		-0.5	-	0.4	V	
Input High Voltage	V _{IH}		V _{CC} -0.4	-	V _{CC} +0.4	V	
Output Low Voltage	V _{OL}	I _{OL} = 100 μA, V _{CC} =V _{CCmin}	-	-	0.1	V	
Output High Voltage	V _{OH}	I _{OH} = -100 μA, V _{CC} =V _{CCmin}	V _{CC} -0.1	-	-	V	
Voltage for Accelerated Program	V _{ID}		8.5	9.0	9.5	V	
Low V _{CC} Lock-out Voltage	V _{LKO}		1.0	-	1.3	V	

Notes:

- Maximum I_{CC} specifications are tested with V_{CC} = V_{CCmax}.
- I_{CC} active while Internal Erase or Internal Program is in progress.
- Device enters automatic sleep mode when addresses are stable for t_{AA} + 60ns.

CAPACITANCE (T_A = 25 °C, V_{CC} = 1.8V, f = 1.0MHz)

Item	Symbol	Test Condition	Min	Max	Unit
Input Capacitance	C _{IN}	V _{IN} =0V	-	10	pF
Output Capacitance	C _{OUT}	V _{OUT} =0V	-	10	pF
Control Pin Capacitance	C _{IN2}	V _{IN} =0V	-	10	pF

Note : Capacitance is periodically sampled and not 100% tested.

AC TEST CONDITION

Parameter	Value
Input Pulse Levels	0V to V _{CC}
Input Rise and Fall Times	5ns
Input and Output Timing Levels	V _{CC} /2
Output Load	C _L = 30pF

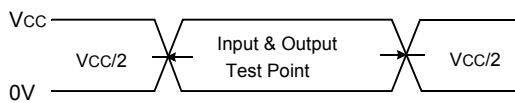

Input Pulse and Test Point

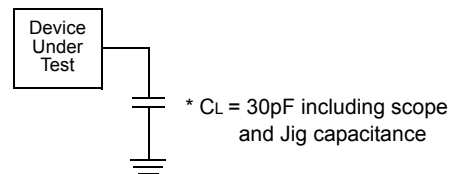

Output Load

AC CHARACTERISTICS

Synchronous/Burst Read

Parameter	Symbol	7B (54 MHz)		7C (66 MHz)		Unit
		Min	Max	Min	Max	
Initial Access Time	t _{IA}	-	88.5	-	70	ns
Burst Access Time Valid Clock to Output Delay	t _{BA}	-	14.5	-	11	ns
$\overline{\text{AVD}}$ Setup Time to CLK	t _{AVDS}	5	-	5	-	ns
$\overline{\text{AVD}}$ Hold Time from CLK	t _{AVDH}	2	-	2	-	ns
$\overline{\text{AVD}}$ High to $\overline{\text{OE}}$ Low	t _{AVDO}	0	-	0	-	ns
Address Setup Time to CLK	t _{ACS}	5	-	5	-	ns
Address Hold Time from CLK	t _{ACH}	7	-	6	-	ns
Data Hold Time from Next Clock Cycle	t _{BDH}	4	-	4	-	ns
Output Enable to Data	t _{OE}	-	20	-	20	ns
Output Enable to RDY valid	t _{OER}	-	14.5	-	11	ns
$\overline{\text{CE}}$ Disable to High Z	t _{CEZ}	-	20	-	20	ns
$\overline{\text{OE}}$ Disable to High Z	t _{OEZ}	-	15	-	15	ns
$\overline{\text{CE}}$ Setup Time to CLK	t _{CES}	7	-	6	-	ns
CLK to RDY Setup Time	t _{RDYA}	-	14.5	-	11	ns
RDY Setup Time to CLK	t _{RDYS}	4	-	4	-	ns
CLK High or Low Time	t _{CLKH/L}	4.5	-	3.5	-	ns
CLK Fall or Rise Time	t _{CLKHCL}	-	3	-	3	ns

SWITCHING WAVEFORMS

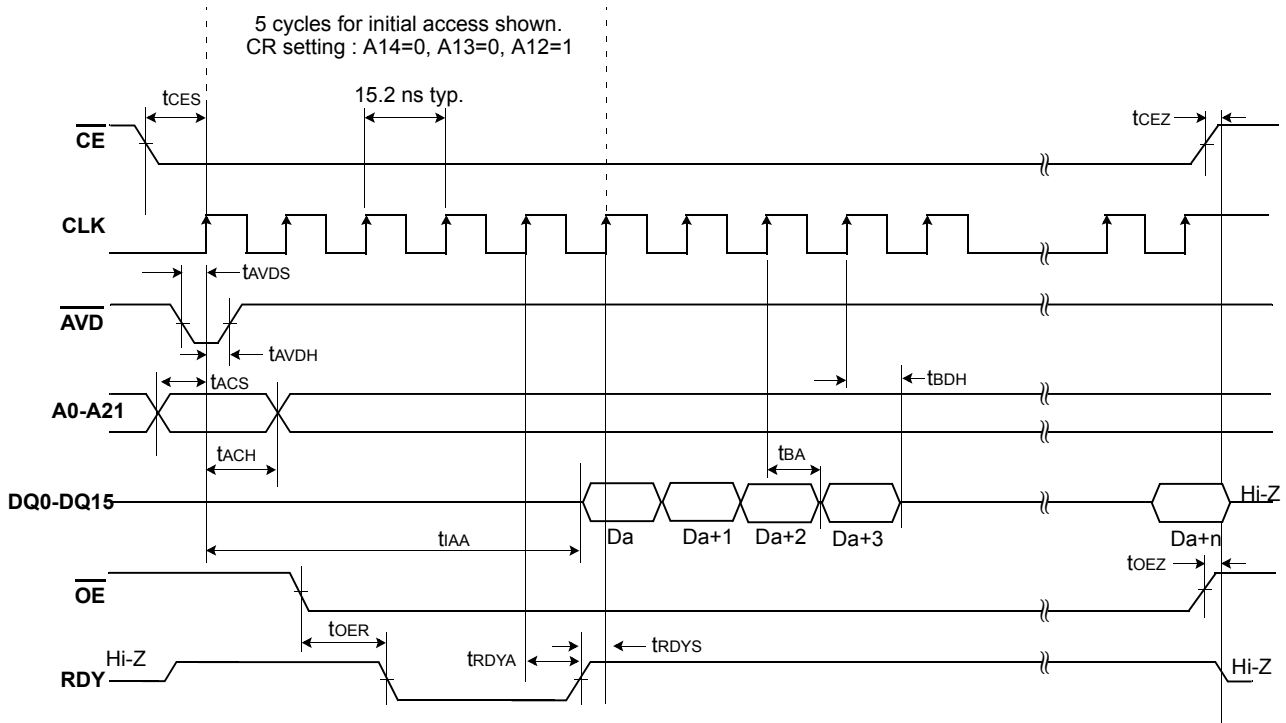

Figure 3. Burst Mode Read (66 MHz)

Note: In order to avoid a bus conflict the \overline{OE} signal is enabled on the next rising edge after \overline{AVD} is going high.

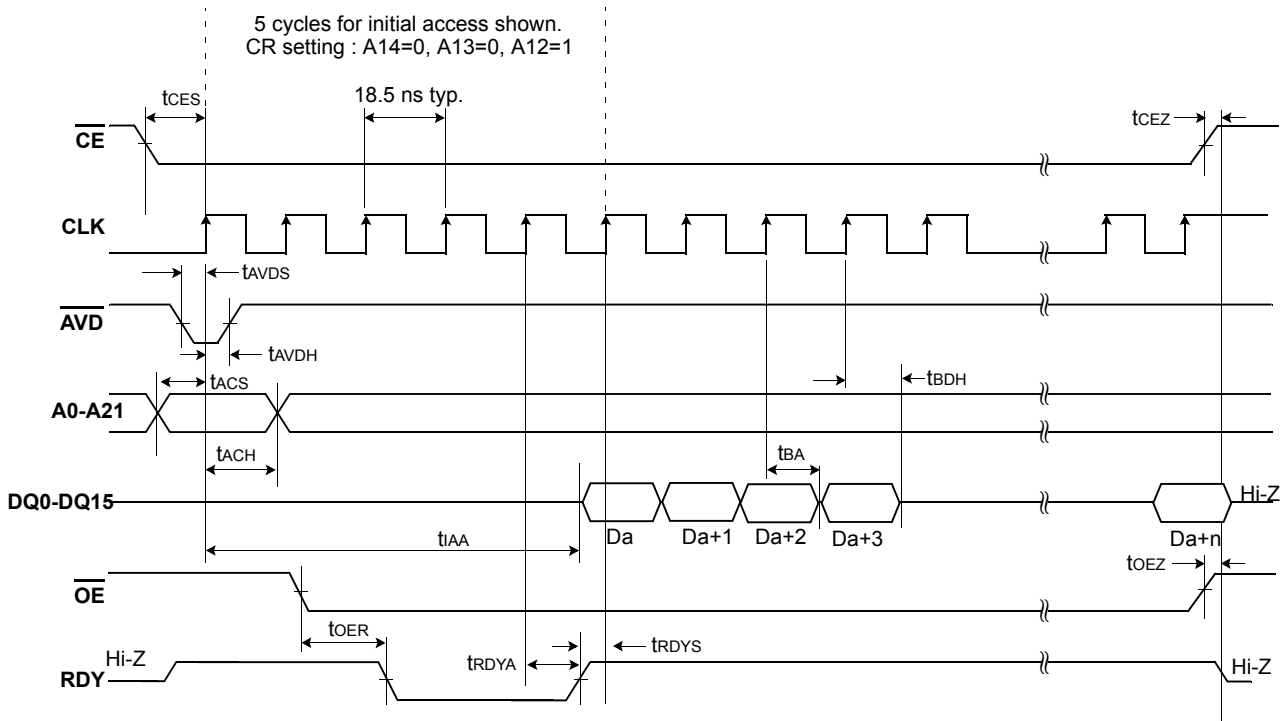

Figure 4. Burst Mode Read (54 MHz)

Note: In order to avoid a bus conflict the \overline{OE} signal is enabled on the next rising edge after \overline{AVD} is going high.

SWITCHING WAVEFORMS

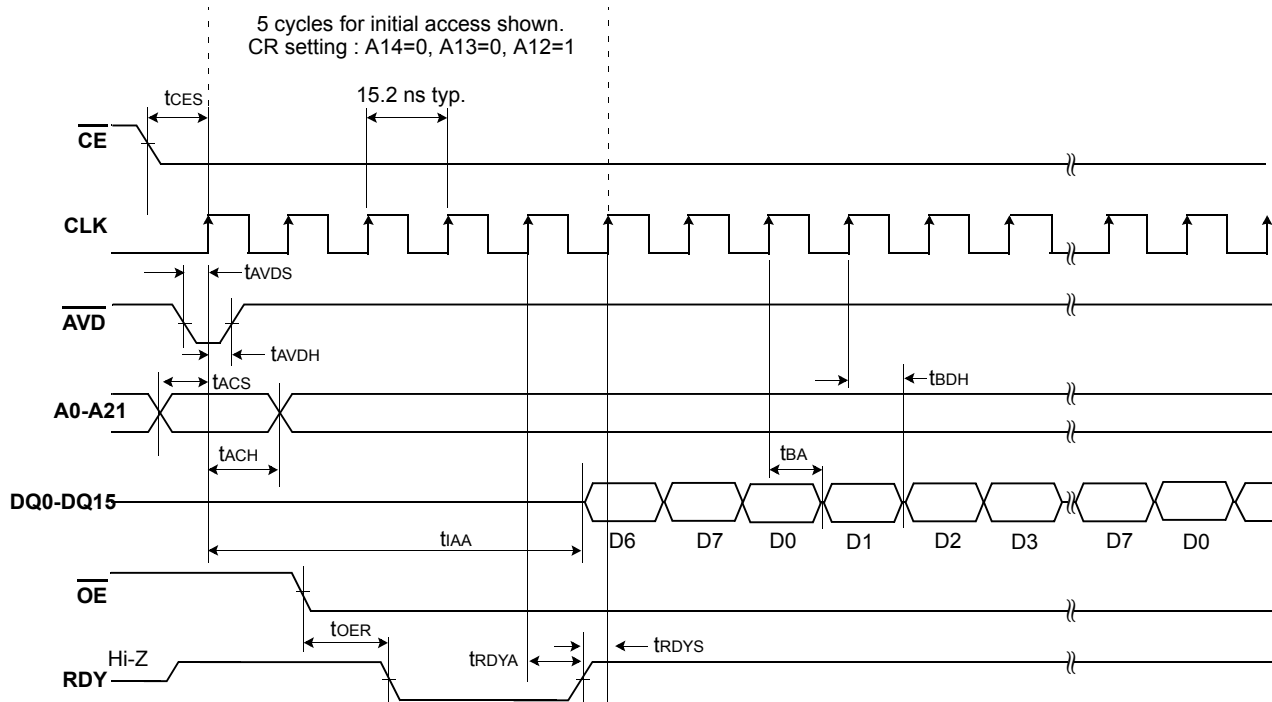

Figure 5. 8 word Linear Burst Mode with Wrap Around (66 MHz)

Note: In order to avoid a bus conflict the \overline{OE} signal is enabled on the next rising edge after \overline{AVD} is going high.

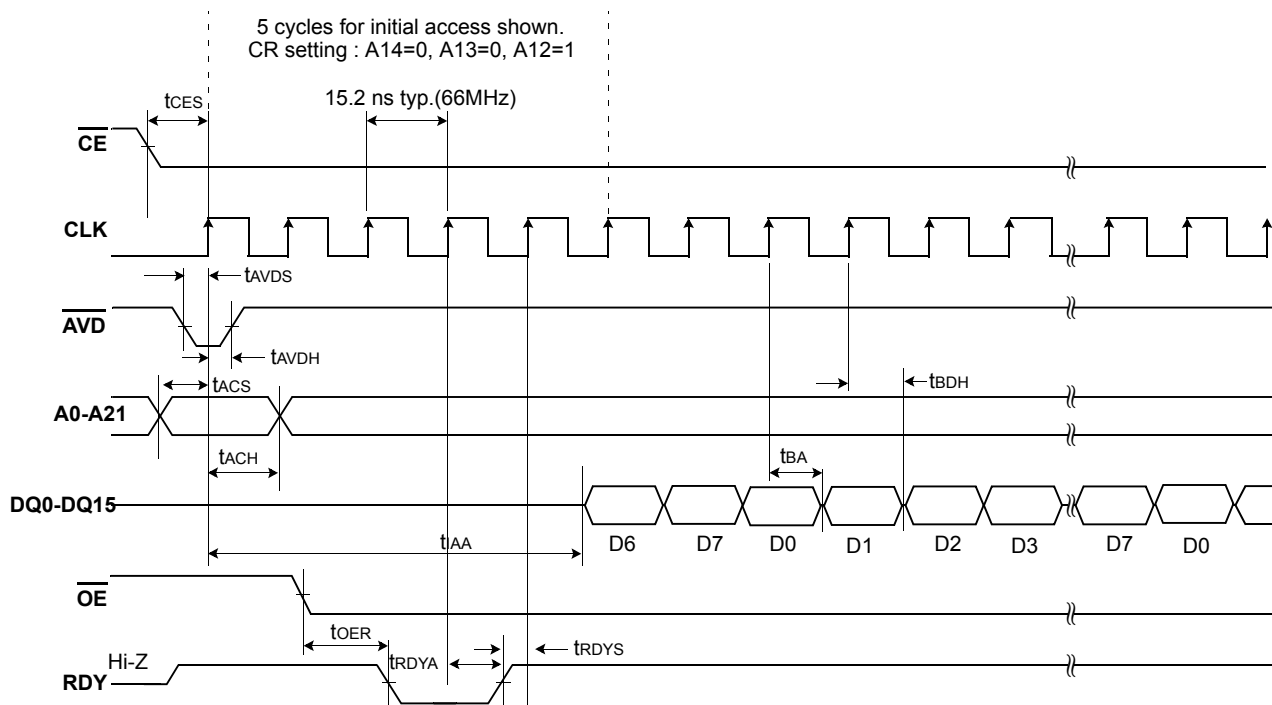

Figure 6. 8 word Linear Burst with RDY Set One Cycle Before Data (CR setting : A18=1)

Note: In order to avoid a bus conflict the \overline{OE} signal is enabled on the next rising edge after \overline{AVD} is going high.

SWITCHING WAVEFORMS

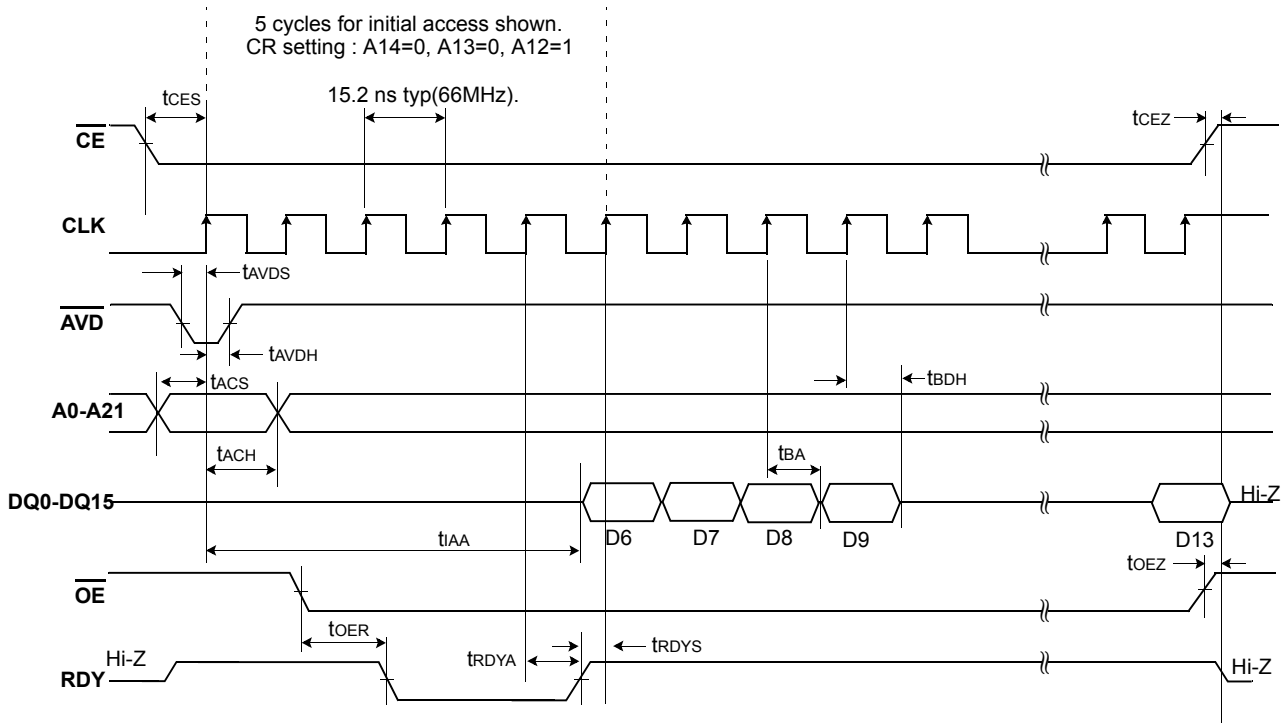

Figure 7. 8 word Linear Burst Mode (No Wrap Case)

Note: In order to avoid a bus conflict the \overline{OE} signal is enabled on the next rising edge after \overline{AVD} is going high.

AC CHARACTERISTICS

Asynchronous Read

Parameter	Symbol	7B		7C		Unit
		Min	Max	Min	Max	
Access Time from \overline{CE} Low	tCE	-	90	-	80	ns
Asynchronous Access Time	tAA	-	90	-	80	ns
\overline{AVD} Low Setup Time to \overline{CE} Enable	tAVDCS	0	-	0	-	ns
\overline{AVD} Low Hold Time from \overline{CE} Disable	tAVDCH	0	-	0	-	ns
Output Enable to Output Valid	tOE	-	20	-	20	ns
Output Enable Hold Time	Read	0	-	0	-	ns
	Toggle and Data Polling	10	-	10	-	ns
Output Disable to High Z(Note 1)	tOEZ	-	15	-	15	ns

Note: 1. Not 100% tested.

SWITCHING WAVEFORMS

Asynchronous Mode Read

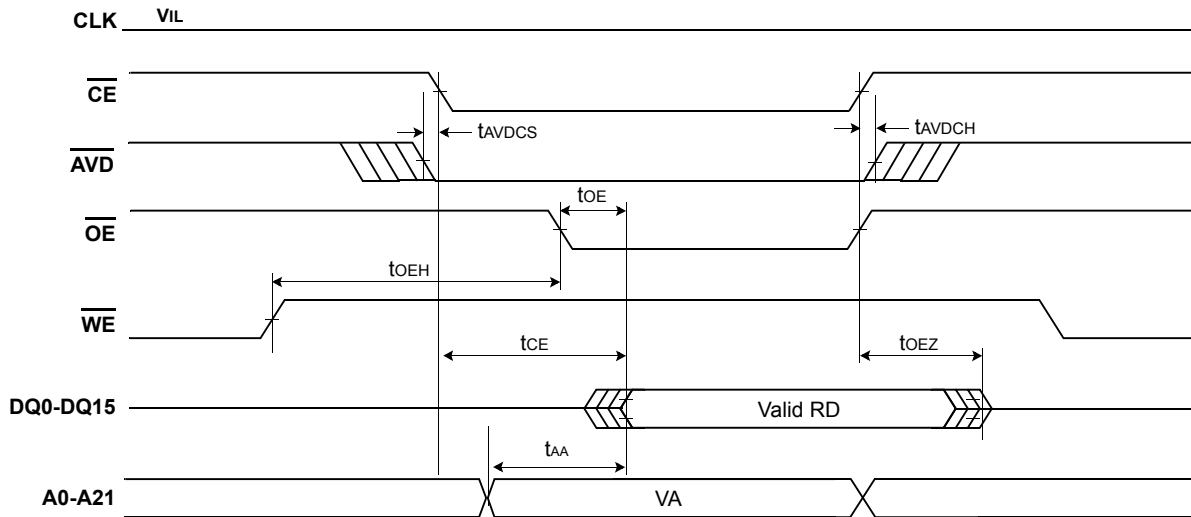

Figure 8. Asynchronous Mode Read

Note: VA=Valid Read Address, RD=Read Data.
Asynchronous mode may not support read following four sequential invalid read condition within 200ns.

AC CHARACTERISTICS

Hardware Reset($\overline{\text{RESET}}$)

Parameter	Symbol	All Speed Options		Unit
		Min	Max	
$\overline{\text{RESET}}$ Pin Low(During Internal Routines) to Read Mode (Note)	t_{Ready}	-	20	μs
$\overline{\text{RESET}}$ Pin Low(NOT During Internal Routines) to Read Mode (Note)	t_{Ready}	-	500	ns
$\overline{\text{RESET}}$ Pulse Width	t_{RP}	200	-	ns
Reset High Time Before Read (Note)	t_{RH}	200	-	ns
$\overline{\text{RESET}}$ Low to Standby Mode	t_{RPD}	20	-	μs

Note: Not 100% tested.

SWITCHING WAVEFORMS

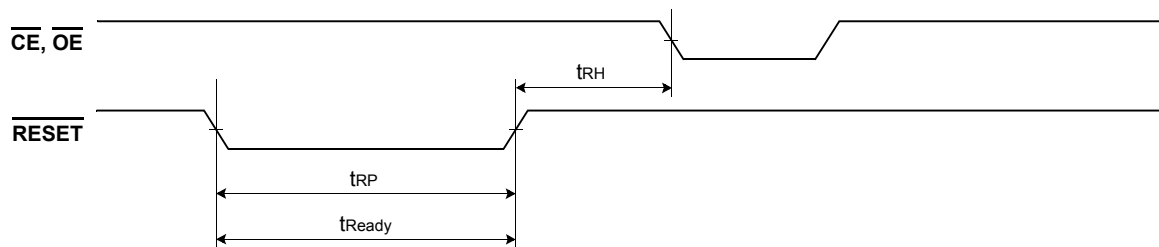

Reset Timings NOT during Internal Routines

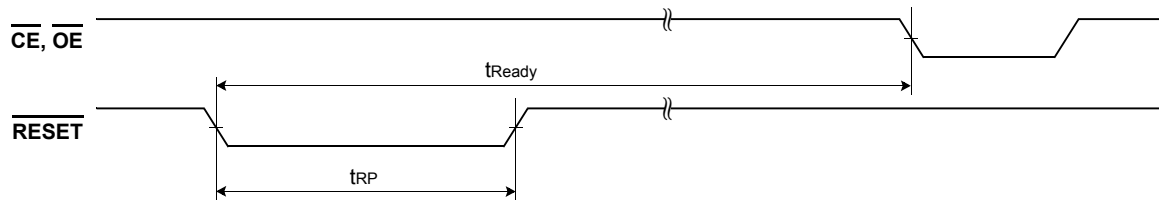

Reset Timings during Internal Routines

Figure 9. Reset Timings

AC CHARACTERISTICS

Erase/Program Operation

Parameter	Symbol	7B, 7C			Unit
		Min	Typ	Max	
\overline{WE} Cycle Time(Note 1)	tWC	100	-	-	ns
Address Setup Time	tAS	0	-	-	ns
Address Hold Time	tAH	50	-	-	ns
Data Setup Time	tDS	50	-	-	ns
Data Hold Time	tDH	0	-	-	ns
Read Recovery Time Before Write	tGHWL	-	0	-	ns
\overline{CE} Setup Time	tCS	5	-	-	ns
\overline{CE} Hold Time	tCH	5	-	-	ns
\overline{WE} Pulse Width	tWP	70	-	-	ns
\overline{WE} Pulse Width High	tWPH	30	-	-	ns
Latency Between Read and Write Operations	tSRW	0	-	-	ns
Word Programming Operation	tPGM	-	11.5	-	μ s
Accelerated Single word Programming Operation	tACCPGM	-	6.5	-	μ s
Accelerated Quad word Programming Operation	tACCPGM_QUAD	-	6.5	-	μ s
Main Block Erase Operation (Note 2)	tBERS	-	0.7	-	sec
V _{PP} Rise and Fall Time	tVPP	500	-	-	ns
V _{PP} Setup Time (During Accelerated Programming)	tVPS	1	-	-	μ s
V _{CC} Setup Time	tVCS	50	-	-	μ s

Notes:

1. Not 100% tested.
2. Not include the preprogramming time.

FLASH Erase/Program Performance

Parameter		Limits			Unit	Comments
		Min.	Typ.	Max.		
Block Erase Time	32 Kword	-	0.7	14	sec	Includes 00h programming prior to erasure
	4 Kword	-	0.2	4		
Chip Erase Time		-	91	-		
Accelerated Chip Erase Time		-	60	-		
Word Programming Time		-	11.5	210	μ s	Excludes system level overhead
Accelerated Single word Programming Time		-	6.5	120		
Accelerated Quad word Programming Time		-	6.5	120		
Chip Programming Time		-	46	-	sec	
Accelerated Singl word Chip Programming Time		-	26	-		
Accelerated Quad word Chip Programming Time		-	6	-		
Erase/Program Endurance (Note 3)		100,000	-	-	Cycles	Minimum 100,000 cycles guaranteed in all Bank

Notes:

1. 25°C, V_{CC} = 1.8V, 100,000 cycles, typical pattern.
2. System-level overhead is defined as the time required to execute the two or four bus cycle command necessary to program each word. In the preprogramming step of the Internal Erase Routine, all words are programmed to 00H before erasure.
3. 100K Program/Erase Cycle in all Bank
4. Requirements for accelerated operation : Ambient temperature : TA=30°C±10°C

SWITCHING WAVEFORMS

Program Operations

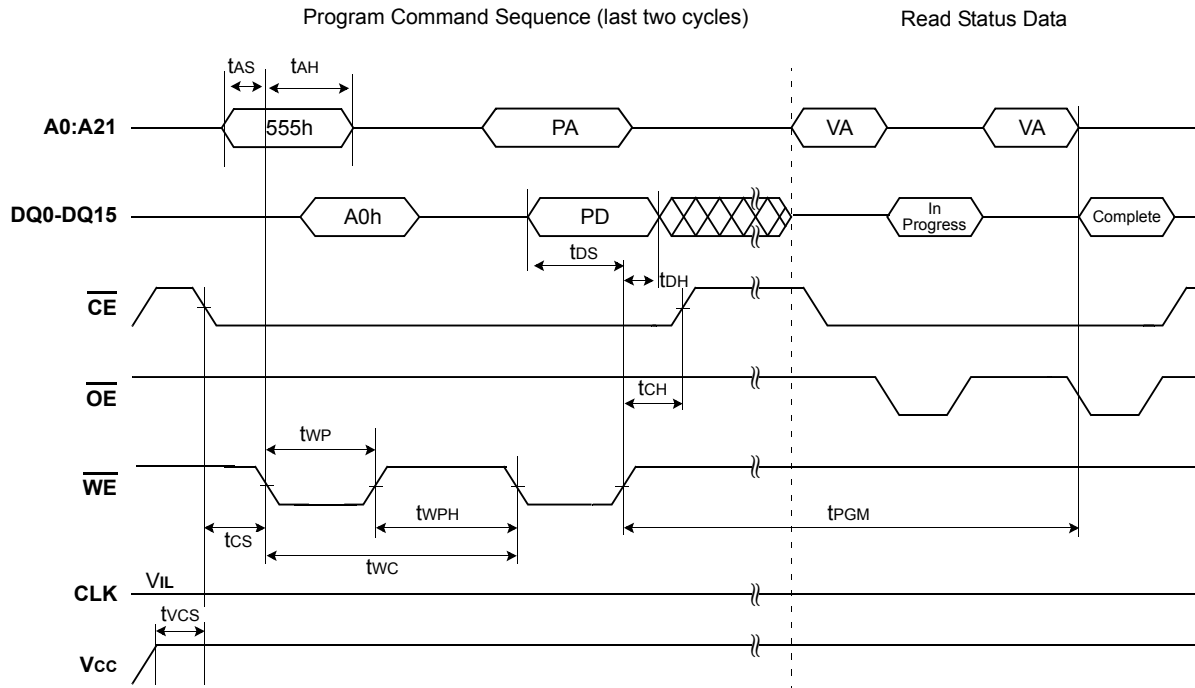

Notes:

1. PA = Program Address, PD = Program Data, VA = Valid Address for reading status bits.
2. "In progress" and "complete" refer to status of program operation.
3. A16–A21 are don't care during command sequence unlock cycles.
4. Status reads in this figure is asynchronous read, but status read in synchronous mode is also supported.
5. AVD Setup/Hold Time to \overline{CE} Enable are same to Asynchronous Mode Read

Figure 10. Program Operation Timing

SWITCHING WAVEFORMS

Erase Operation

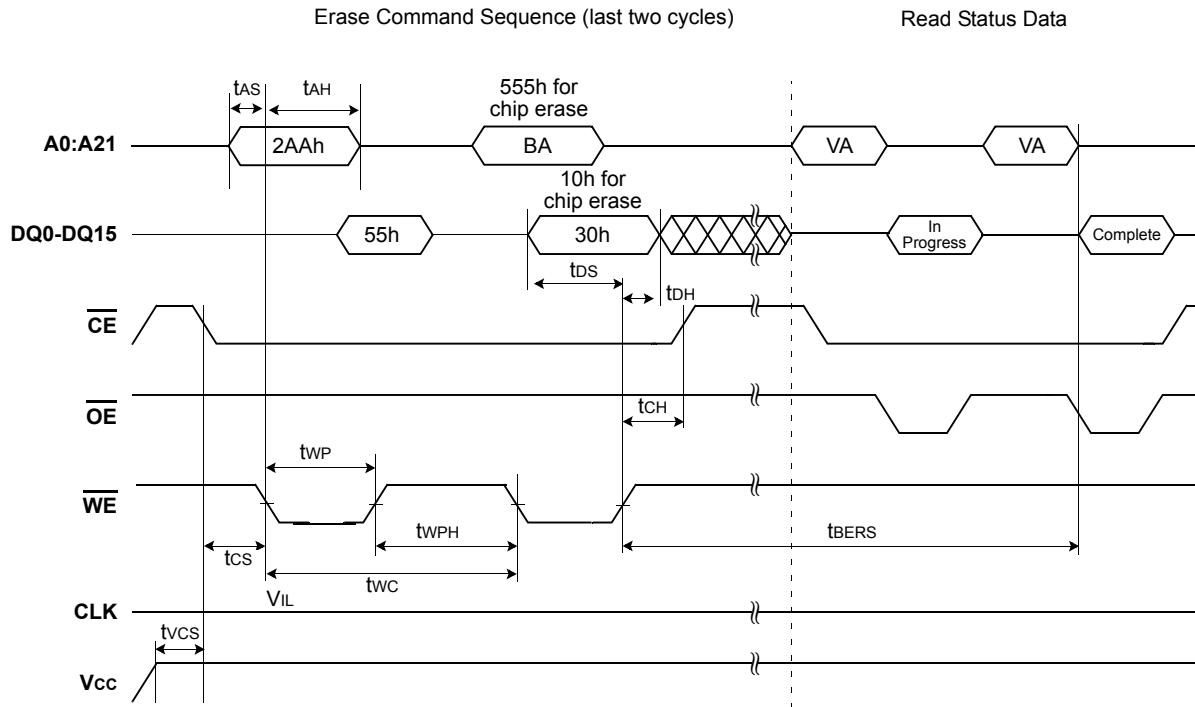

Notes:

1. BA is the block address for Block Erase.
2. Address bits A16–A21 are don't cares during unlock cycles in the command sequence.
3. Status reads in this figure is asynchronous read, but status read in synchronous mode is also supported.
4. \overline{AVD} Setup/Hold Time to \overline{CE} Enable are same to Asynchronous Mode Read

Figure 11. Chlp/Block Erase Operations

SWITCHING WAVEFORMS

Unlock Bypass Program Operations(Accelerated Program)

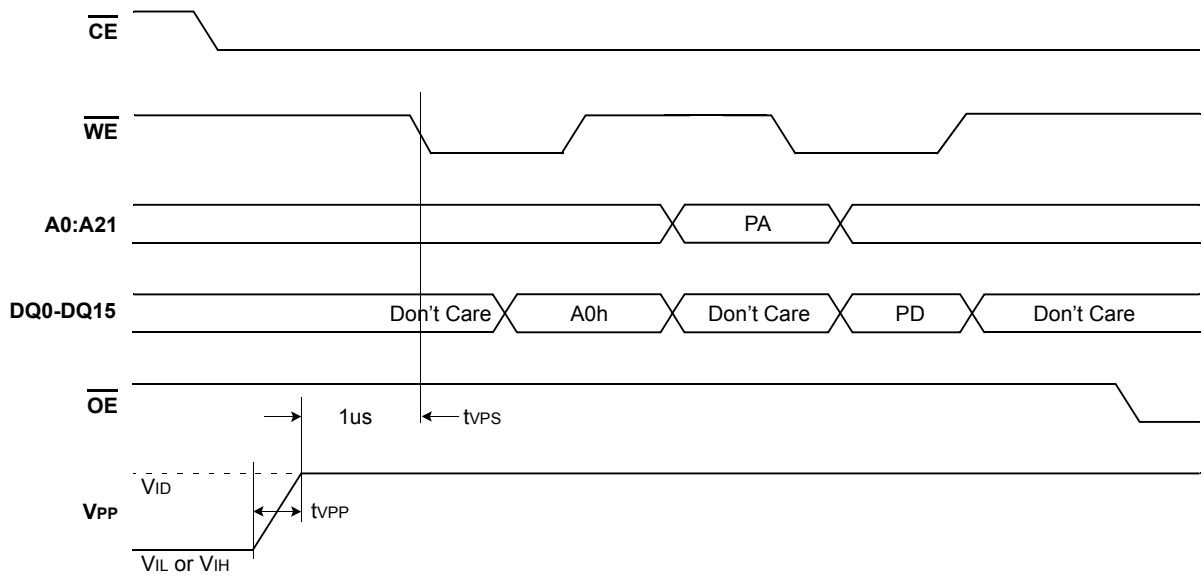

Unlock Bypass Block Erase Operations

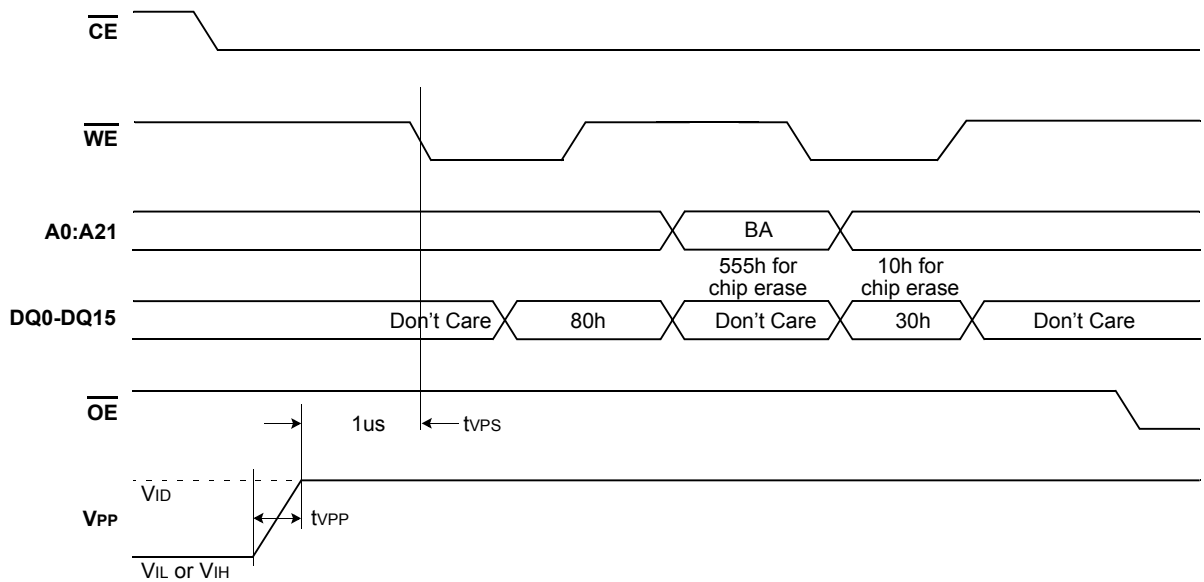

Notes:

1. V_{PP} can be left high for subsequent programming pulses.
2. Use setup and hold times from conventional program operations.
3. Unlock Bypass Program/Erase commands can be used when the V_{ID} is applied to V_{pp} .
4. \overline{AVD} Setup/Hold Time to \overline{CE} Enable are same to Asynchronous Mode Read

Figure 12. Unlock Bypass Operation Timings

SWITCHING WAVEFORMS

Data Polling Operations

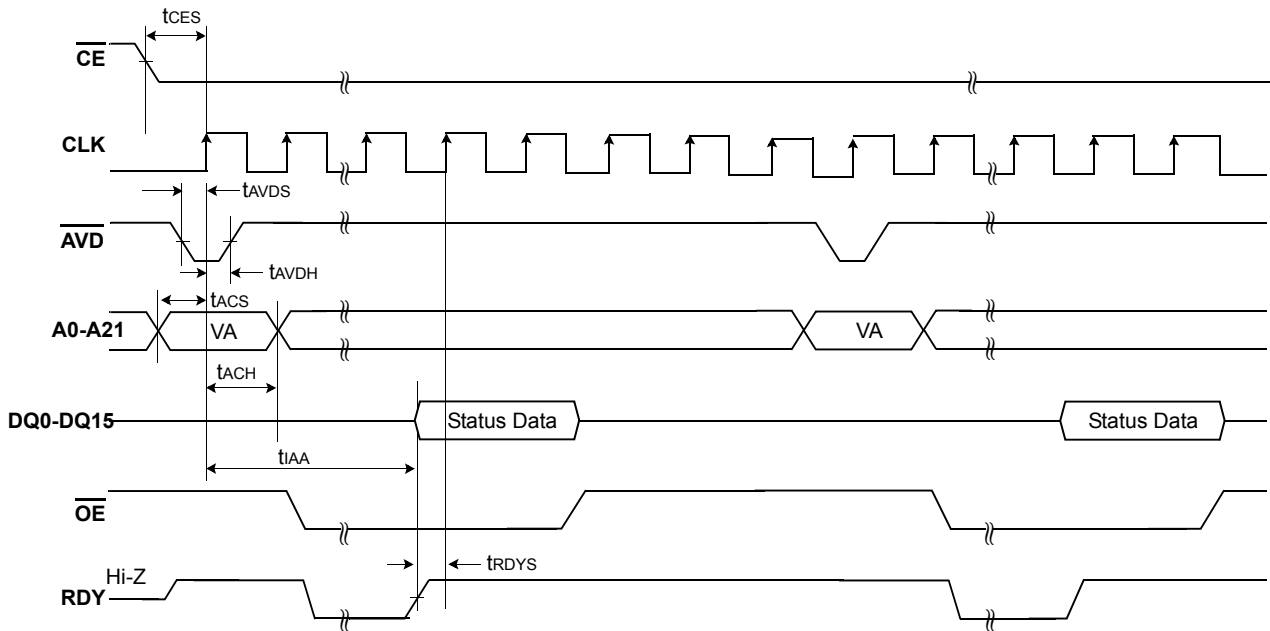

Notes:

1. VA = Valid Address. When the Internal Routine operation is complete, and \overline{Data} Polling will output true data.

Figure 13. Data Polling Timings (During Internal Routine)

Toggle Bit Operations

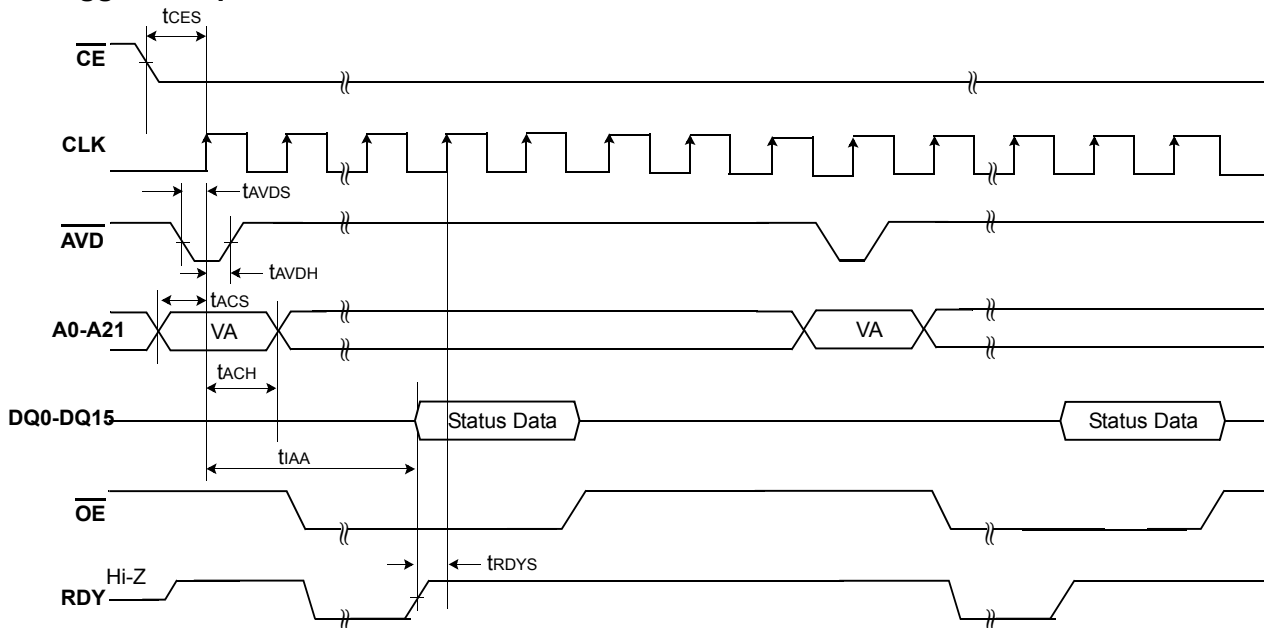

Notes:

1. VA = Valid Address. When the Internal Routine operation is complete, the toggle bits will stop toggling.

Figure 14. Toggle Bit Timings(During Internal Routine)

SWITCHING WAVEFORMS

Read While Write Operations

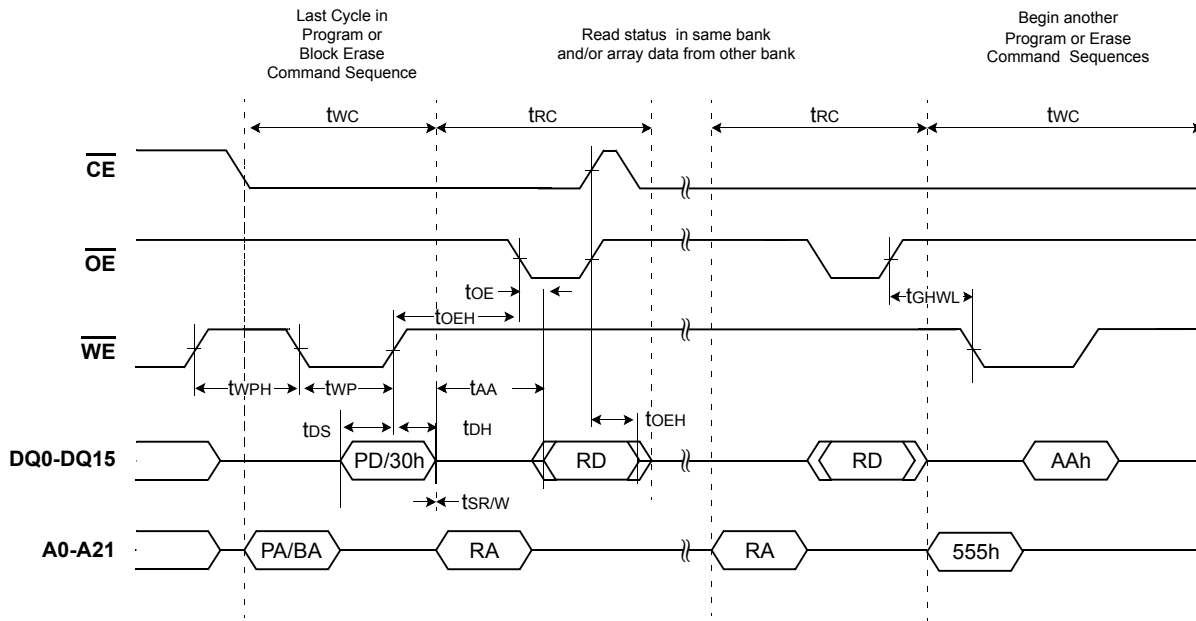

Figure 15. Read While Write Operation

Note:

Breakpoints in waveforms indicate that system may alternately read array data from the "non-busy bank" and checking the status of the program or erase operation in the "busy" bank.

Crossing of First Word Boundary in Burst Read Mode

The additional clock insertion for word boundary is needed **only at the first crossing** of word boundary. This means that no additional clock cycle is needed from 2nd word boundary crossing to the end of continuous burst read. Also, the number of additional clock cycle for the first word boundary can varies from zero to three cycles, and the exact number of additional clock cycle depends on the starting address of burst read.

The rule to determine the additional clock cycle is as follows. All addresses can be divided into 4 groups. The applied rule is "The residue obtained when the address is divided by 4" or "two LSB bits of address". Using this rule, all address can be divided by 4 different groups as shown in below table. For simplicity of terminology, "4N" stands for the address of which the residue is "0"(or the two LSB bits are "00") and "4N+1" for the address of which the residue is "1"(or the two LSB bits are "01"), etc.

The additional clock cycles for first word boundary crossing are zero, one, two or three when the burst read start from "4N" address, "4N+1" address, "4N+2" address or "4N+3" address respectively.

Starting Address vs. Additional Clock Cycles for first word boundary

Starting Address Group for Burst Read	The Residue of (Address/4)	LSB Bits of Address	Additional Clock Cycles for First Word Boundary Crossing
4N	0	00	0 cycle
4N+1	1	01	1 cycle
4N+2	2	10	2 cycles
4N+3	3	11	3 cycles

Case 1 : Start from "4N" address group

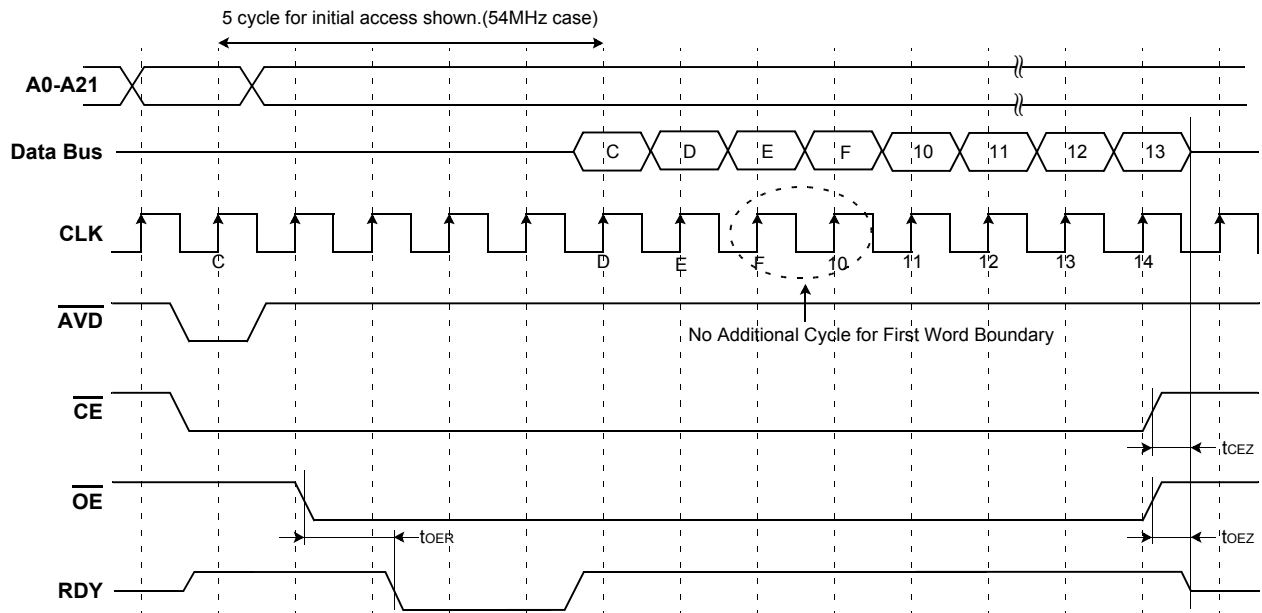

Notes:

1. Address boundry occurs every 16 words beginning at address 00000FH , 00001FH , 00002FH , etc.
2. Address 000000H is also a boundry crossing.
3. No additional clock cycles are needed except for 1st boundary crossing.

Figure 16. Crossing of first word boundary in burst read mode.

Case 2 : Start from "4N+1" address group

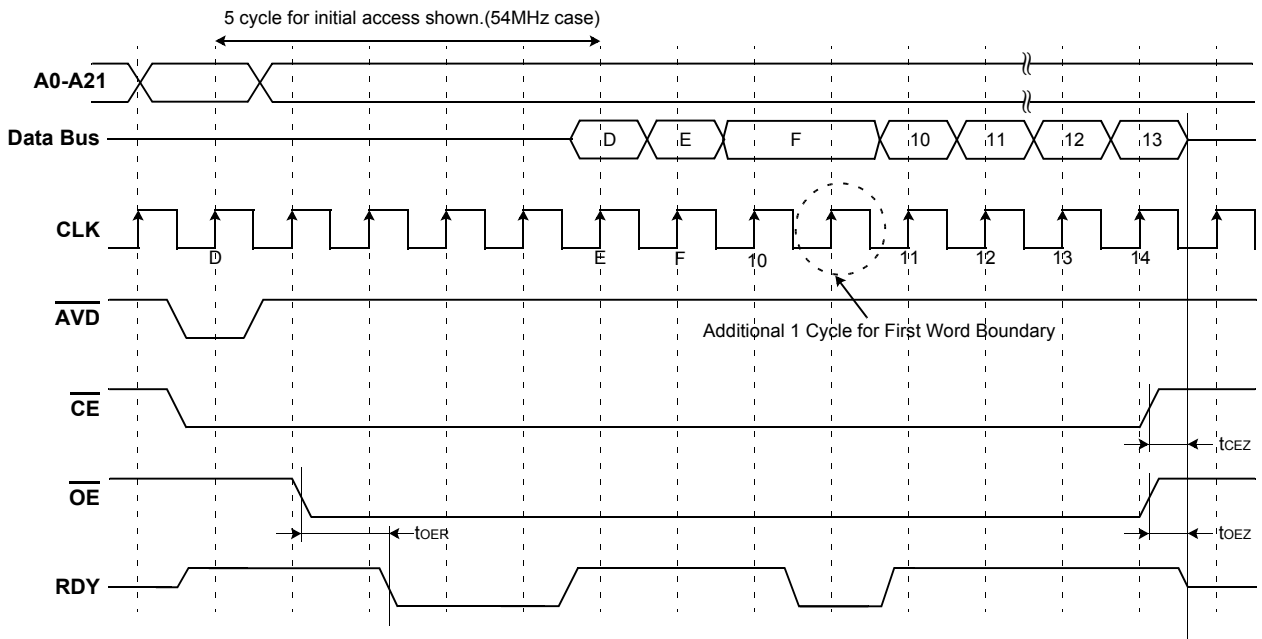

Case 3 : Start from "4N+2" address group

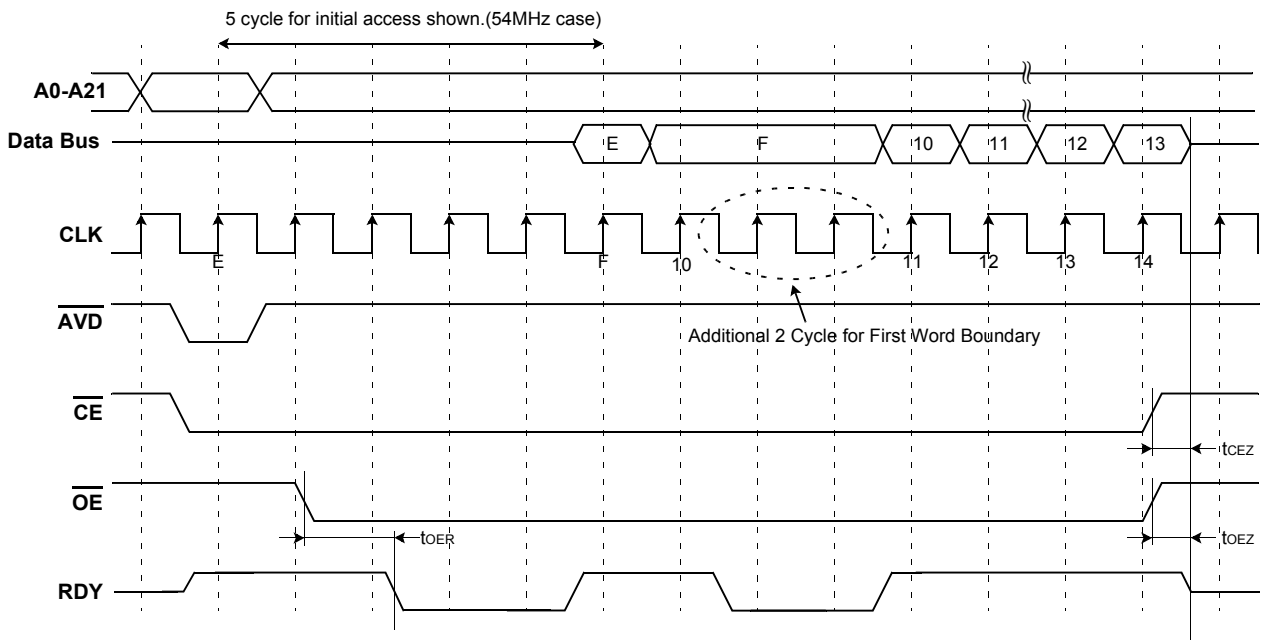

Notes:

1. Address boundary occurs every 16 words beginning at address 00000FH , 00001FH , 00002FH , etc.
2. Address 000000H is also a boundary crossing.
3. No additional clock cycles are needed except for 1st boundary crossing.

Figure 17. Crossing of first word boundary in burst read mode.

Case4 : Start from "4N+3" address group

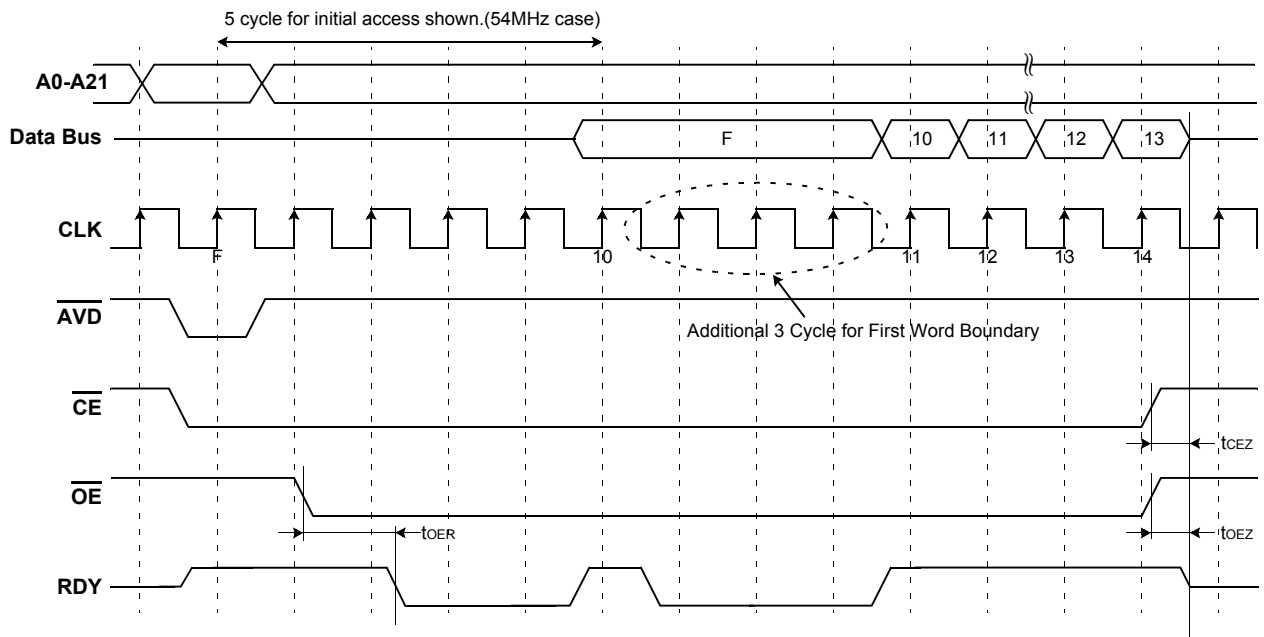

Notes:

1. Address boundary occurs every 16 words beginning at address 00000FH , 00001FH , 00002FH , etc.
2. Address 000000H is also a boundary crossing.
3. No additional clock cycles are needed except for 1st boundary crossing.

Figure 18. Crossing of first word boundary in burst read mode.