

Ether Module™-EM2/R
10Base-2

**Ethernet Transceiver Module with on Board
Isolation Transformer & DC/DC Converter**

PRELIMINARY

SEEQ TECHNOLOGY INC

April 1993

Introduction

The Thin Net (Cheapernet) module provides a complete Local Area Network interface for a station, without a transceiver cable. The module contains all circuit components for a complete Thin Net COAX interface and includes an on-board CMOS 83C92 transceiver DC/DC converter and isolation transformers.

The module is compatible with ANSI/IEEE 802.3 and ISO 8802-3.

The module is part of a chipset manufactured by SEEQ Technology to provide the basic components for a LAN interface board. The other components include the 8005/80C04 Advanced Ethernet Data Link Controllers (AEDLC™) and the 8020 or 8023A Manchester Code Converter (MCC™).

Features

- The module is compatible with ANSI/IEEE 802.3 and ISO 8802-3 Standards for Thin Net (10BASE2).
- Contains all Thin Net COAX transceiver functions on one chip.

- Squelch circuits on all signal inputs to eliminate noise.
- Collision Test Generator, externally deselectable to work with any ANSI/IEEE 802.3 and ISO 8802-3 repeater.
- Detects and reports network collisions in both transmit and receive modes.
- Implemented with SEEQ proprietary high voltage (20V) and high performance CMOS process.
- Loopback test detects network cable opens or shorts.
- Power On Reset prevents transmission during power up.
- DC to DC Converter on board.
- Disable pin to power-down module.
- Isolation Transformers on board.

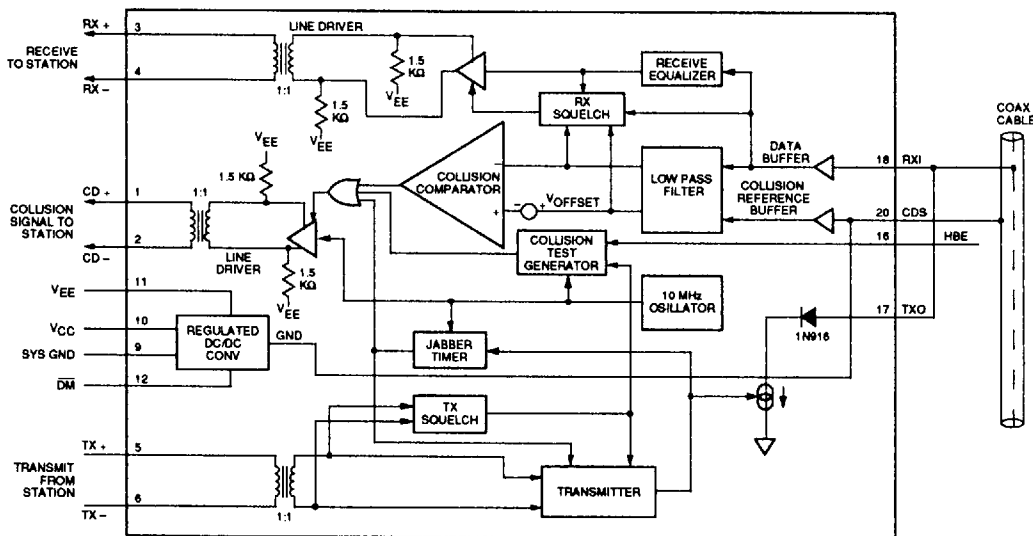

Figure 1. Ethernet Transceiver Module Block Diagram

AEDLC, MCC and Ether Module are trademarks of SEEQ Technology, Inc.

PRELIMINARY

Ether Module - EM2/R
10Base-2

SEEQ TECHNOLOGY INC

Description

The Thin Net module connects the station equipment to a Thin Net (Cheapernet) COAX cable. The on-board 83C92 CMOS COAX transceiver provides the drive current and wave shaping for the transmit signals. It supplies receive signal equalization, collision detection and squelch.

Description of the Pin Functions**PIN # FUNCTION**

- 1 - 2 **CD± Collision Output.** A balanced 10 MHz differential output to the station equipment when a collision is detected, when excessive data transmission occurs (jabber), or during the Collision Test (Heartbeat Test).
- 3, 4 **RX± Receive Data Output.** Line Driver output to the MCC Receive inputs.
- 11 **V_{EE} Negative Supply.** Nominally -9 volts referenced to COAX shield ground.

An on-board DC-DC power converter provides -9 volt power for the on-board module, and DC isolation from the station equipment to prevent ground loop current.

- 5 - 6 **TX± Transmit Data Input.** A balanced line receiver input to the module from the MCC for transmit packets.
- 16 **HBE Heartbeat Enable.** This input enables the Collision (also called Heartbeat) Test when connected to ground or floating, and disables the test when connected to V_{EE}. This function is available only on the EM2R. On EM2, HBE is permanently enabled and pin 16 is not used.
- 9 **SYS GND Ground.** System Ground is referenced to V_{CC}.
- 18 **RXI Network Signal Receiver.** Connects to the network COAX center conductor, and receives packet data and detects the collision voltage level.
- 17 **TXO Network Signal Transmitter.** Connects to the network COAX center conductor through an internal 1N916 diode, and transmits all signals from the MCC to the network.
- 20 **CDS Collision Detect Sense.** Connects directly to the network shield, and references the collision detection voltage level.

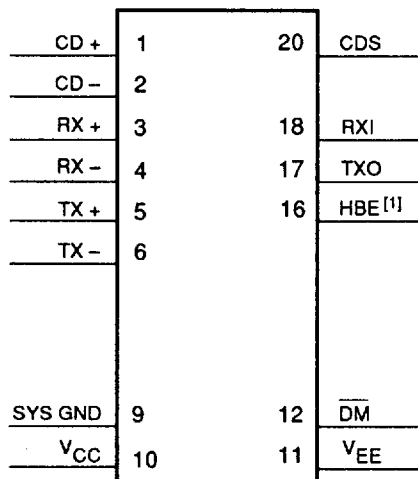
TOP VIEW

Note: [1] HBE function on pin 16 is available only on EM2R. On EM2 pin 16 is a NO CONNECT.

Figure 2. Ethernet Transceiver Module Pin Configuration

PRELIMINARY

SEEQ TECHNOLOGY INC

Ether Module - EM2/R
10Base-2

- 12 **DM** Disable module is an active low signal (internal $10K\Omega$ pullup) that may be utilized to turn off the Ether module in the event an alternative transceiver is used, or for power conservation purposes.

Description of the Module Functions

The module has five main functions, as shown in the block diagram. These are the Transmitter; the Collision Detector; the Jabber Timer; the Receiver; and the DC/DC Converter. The on-board 83C92 provides all functions except DC/DC converter and AUI signal isolation.

The Transmitter

The Transmitter takes differential output signals from the MCC, and outputs these signals at the correct levels to the network.

The transmit signal is sent to the module via a balanced differential pair (TX \pm). A squelch circuit prevents the Transmitter Output from responding to noise on the TX \pm pair. The Transmitter has an open-collector current driver output using the V_{EE} supply. Rise and fall times are controlled and set at 25 ns/V to lessen the higher harmonics. Drive current levels are set by a bandgap voltage reference and an internal 1K resistor. An internal diode is also added to reduce COAX loading and capacitance to comply with the ISO and ANSI/IEEE specifications.

The transmit squelch circuit blocks signals with pulse widths less than 15 nanoseconds, (negative-going), or with levels of less than -175 millivolts. The squelch circuits turn the Transmitter off at the end of a packet if the signal stays higher than -175 millivolts for more than 190 nanoseconds. See Figure 3, the Transmitter Timing Diagram.

The TXO signal is disabled when not transmitting to prevent noise on the network. If the COAX cable is shorted or open, no transmitted data appears on the Receiver input. This condition can be detected by the station equipment by running a loopback test.

Collision Detection

The Collision detector monitors the COAX Center Conductor and senses the voltage conditions created by a collision, where the COAX shield is used as a reference. A collision condition can be detected when two or more stations are transmitting, whether or not the local Transmitter is activated. This is called Receive Mode Collision Detection.

The detector signals a collision by sending the 10 MHz oscillator signal through the Collision Pair (CD \pm) to the MCC. The HeartbeatTest is performed at the end of each transmitted data packet to verify the operation of the detector.

A collision causes a -2.0 volt average DC level on the center conductor of the network cable. This level passes through a 4-pole Bessel low-pass filter for averaging. The resulting signal is measured by a voltage comparator against the threshold voltage V_{CD} of about -1.5 volts. A collision is indicated when the center conductor average level is more negative than the CDS level by the threshold V_{CD} . The line driver is enabled within 900 ns of the onset of the collision, and the 10 MHz signal is sent to the station equipment.

The Heartbeat Test is a short burst of the collision signal generated immediately after the transmission of a packet. This test enables the 10 MHz collision signal for about 1

ETHER
MODULE

Figure 3. Transmitter Timing

SEEQ
Technology, Incorporated

MD400122/A

PRELIMINARY

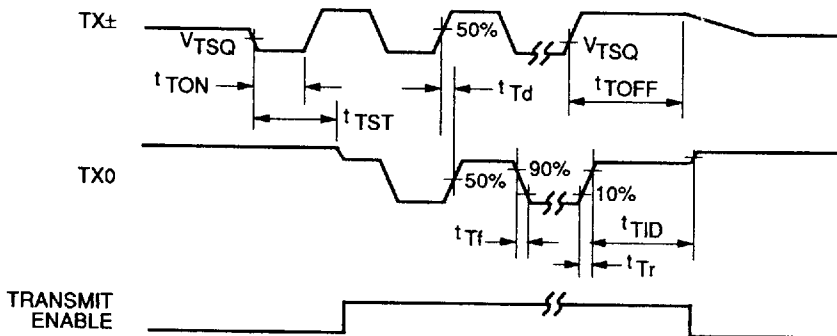
SEEQ TECHNOLOGY INC

Ether Module - EM2/R
10Base-2

microsecond starting about 1.1 microseconds after the end of transmission. The test can be disabled for operation with repeaters by connecting the HBE pin to V_{EE} .

The Jabber Timer

The Jabber Timer monitors the operation of the Transmitter, using the 10 MHz Oscillator as a time base. If the Transmitter operates continuously for more than typically 40 Milliseconds, the Jabber Timer disables the Transmitter and enables the Collision Detector outputs. The Transmitter is automatically re-enabled after the station has been silent for 500 milliseconds.

The Receiver

The Receiver detects any signal on the COAX center conductor that triggers its squelch circuits, and sends the signal through a differential line driver to the MCC. The Receiver provides amplification and equalization; a squelch circuit prevents noise activating the Receiver circuits. See Figure 4.

The receive signal goes through a buffer with a high input impedance and low capacitance to reduce loading and reflections on the network COAX. An equalizer passes high frequencies and attenuates low frequency signals from the network, flattening the network pass band. The signal is output through a differential line driver presenting a balanced signal to the station. The line driver has 4 nanosecond rise and fall times.

A 4-pole Bessel low-pass filter provides the average DC level from the received signal. It sends this level to the Collision Comparator and RX Squelch circuits. The squelch circuit activates the Receive Line Driver only when it detects a true signal. This prevents noise triggering the receiver.

When a packet is detected, the DC level from the Low-pass Filter becomes more negative than the DC squelch threshold, and the Receiver turns on. The squelch circuit AC timing detects high level signals of more than 225 nanoseconds, and turns the Receiver off. The Receiver stays off if within 1 microsecond (typical) the low pass filter level becomes more positive than the DC squelch threshold. See the Receiver Timing Diagram, Figure 4.

The System Connections diagram shows the transceiver connections in a station environment. RX_{\pm} and CD_{\pm} differential signals to the MCC are biased by 1.5K ohm pull-down resistors and are isolated from the MCC. The DC supply is converted to -9V by a DC to DC converter. This converter also provides DC isolation between the +5 volt and -9 volt sides.

The COAX center conductor connects to the Receive and Transmit pins of the transceiver. A 1N916 internal diode minimizes network loading when power is on or off. COAX tap capacitance contributed by the Thin Net module is less than 4 pF at 10 MHz, powered and unpowered, not trans-

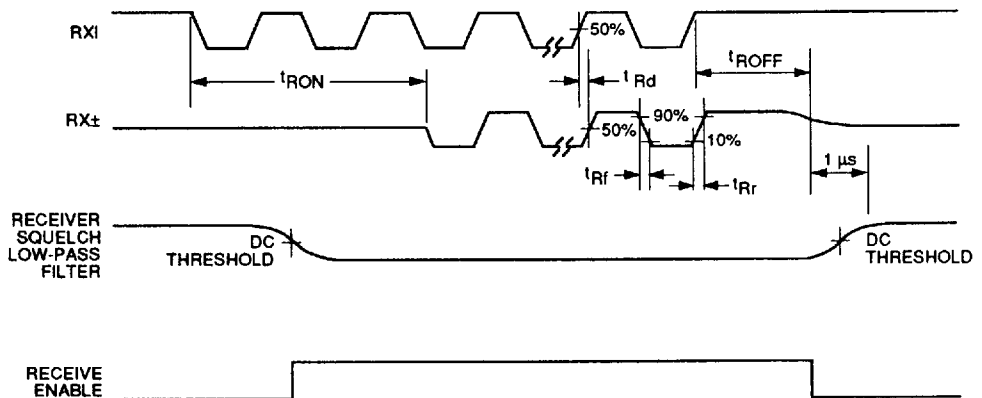

Figure 4. Receiver Timing

SEEQ
Technology, Incorporated

MD400122/A

PRELIMINARY

Ether Module - EM2/R
10Base-2

SEEQ TECHNOLOGY INC

mitting. CDS, Collision Detection Sense detects the Collision reference level. This is ground-referenced sense pin. It should be connected directly to the COAX shield to prevent ground-loop interference.

The Transceiver assembly includes the DC - DC Converter and a pulse transformer for RX±, TX± and CD± signal isolation.

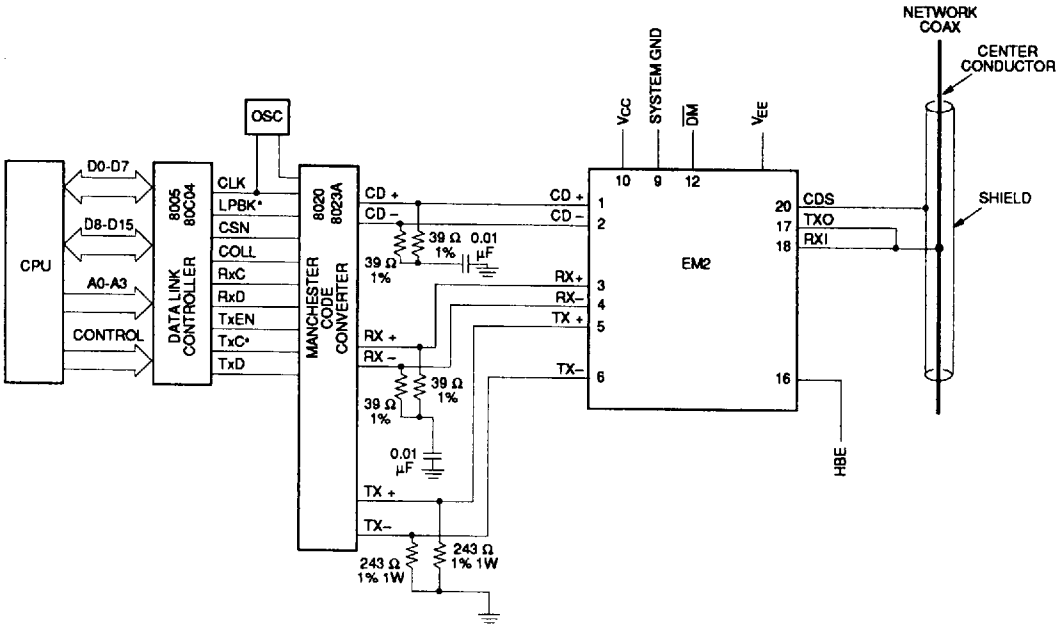

Figure 5. Ethernet Transceiver System Connections

PRELIMINARY

Ether Module - EM2/R
10Base-2

SEEQ TECHNOLOGY INC

Absolute Maximum Ratings*

Input Voltage 0 to 7V Vcc
 Operating Temperature 0° to 70° C
 Storage Temperature -20° to 85° C
 DC Isolation Voltage 500V DC
 AC Isolation Voltage 500V AC

**COMMENT: Stresses above those listed under "Absolute Maximum Ratings" may cause permanent damage to the device. This is a stress rating only and functional operation of the device at these or any other conditions above those indicated in the operational sections of this specification is not implied. Exposure to absolute maximum rating conditions for extended periods may affect device reliability.*

**Operating Parameters for
DC to DC Converter**

MIN TYP MAX UNIT(S)

Input Voltage	V _{in}	4.75	5	5.25	V
Max Input Current ⁽¹⁾	I _{cc}			380 ⁽¹⁾	ma
Efficiency		60	68		%
Ripple Voltage	V _n Out		91	120	mV P-P

**Operating Parameters
for Module**

MIN MAX

Input (TAP) Capacitance	C _{rx} +C _{tx}		4	pf
Isolation Impedance	Z _{iso}	250		KΩ

SEEQ[®]

Technology, Incorporated

MD400122/A

PRELIMINARY

Ether Module - EM2/R
10Base-2

SEEQ TECHNOLOGY INC

Electrical Characteristics $V_{CC} = 5V \pm 5\%$, $T_A = 0^\circ$ to $70^\circ C$ (See Notes 1, 2 & 3)

Symbol	Parameter	Min	Typ	Max	Units
I_{CC1}	Supply Current Non Transmitting			225	mA
I_{CC2}	Supply Current Transmitting ^[5]			300	mA
I_{RXI}	Receive Input Bias Current (RXI) ^[5]	-2	-1	+25	μA
I_{TDC}	Transmit Output DC Current Level (TXO)	37	41	45	mA
I_{TAC}	Transmit Output AC Current Level (TXO)	± 28		I_{TDC}	mA
V_{CD}	Collision Threshold (Receive Mode) ^[2]	-1.45	-1.53	-1.58	V
V_{OD}	Differential Output Voltage (RX \pm , CD \pm) ^[2]	± 475		± 1200	mV
V_{OC}	DC Common Mode Output Voltage (RX \pm , CD \pm) ^{[1][7]}		-2.0		V
V_{OB}	Idle State Differential Offset Voltage (RX \pm , CD \pm) ^[7]		± 40		
V_{OA}	AC Common Mode Output Voltage (RX \pm , CD \pm) ^[7]		± 40		mV
V_{TSO}	Transmitter Squelch Threshold (TX \pm)	-175	-225	-300	mV
C_x	TAP Capacitance ^[4]			4	pF
R_{RXI}	Shunt Resistance—Non Transmitting (RXI) ^[5]	100			K Ω
R_{TXO}	Shunt Resistance—Transmitting (TXO) ^{[2][6]}	7.5			K Ω
Harmonic Content Relative to Fundamental					
$H_{c2,3}$	Second and Third Harmonics	-20			dB
$H_{c4,5}$	Fourth and Fifth Harmonics	-30			dB
$H_{c6,7}$	Sixth and Seventh Harmonics	-40			dB

NOTES

- V_{OC} has no impact on system performance, since the twisted pair is transformer - isolated.
- As required to meet ANSI/IEEE 802.3 and ISO 8802-3 specifications.
- All currents into device pins are positive, all currents out of device pins are negative. All voltages referenced to ground unless otherwise specified.
- Measured at RXI. Guaranteed through characterization.
- Current is measured on RXI while first forcing 0 volt and measuring the current, and then forcing -2 volts and measuring the current.

Thus:

$$R = \frac{\Delta V}{\Delta I} = \frac{2V}{[I @ 0V] - [I @ -2V]}$$

- TX \pm is first set to 1 volt differential (DC voltage) to surpass the squelch level. Current is measured on TXO while first forcing 0 volt and measuring the current, and then forcing -2 volts and measuring the current. Calculation is the same as item 5 above.
- Values shown are internal to the module and are shown to indicate module capability only.
- Values as shown is for 50% duty cycle, for 100% duty cycle $I_{CC2} = 380$ ma.

ETHER
MODULE



PRELIMINARY

Ether Module - EM2/R
10Base-2

SEEQ TECHNOLOGY INC

Recommended Operating Conditions

Supply Voltage (V_{CC}) 5V \pm 5%
Ambient Temperature 0° to 70°C

Switching Characteristics $V_{CC} = 5V \pm 5\%$, $T_A = 0^\circ$ to $70^\circ C$

Symbol	Parameter	Fig	Min	Typ ⁽¹⁾	Max	Units
t_{TST}	Transmitter Startup Delay (TX \pm to TXO) ⁽²⁾	3		1	2	bits
t_{TD}	Transmitter Propagation Delay (TX \pm to TXO)	3	15	25	50	ns
t_{JA}	Jabber Activation Delay (TX \pm to TXO and CD \pm) ⁽²⁾	8	20	40	60	ms
t_{JR}	Jabber Reset Timeout (TX \pm to TXO and CD \pm)	8	250	500	750	ms
t_{RD}	Receiver Propagation Delay (RXI to RX \pm)	4		15	50	ns
t_{TM}	t_r and t_n Mismatch			0.5		ns
t_{RON}	Receiver Startup Delay (RXI to RX \pm) ⁽²⁾	4		4	5	bits
t_{CON}	Collision Turn-On Delay ⁽²⁾	6		7		bits
t_{COFF}	Collision Turn-Off Delay	6			20	bits
f_{CD}	Collision Frequency (CD \pm)	6			12	MHz
t_{CP}	Collision Pulse Width (CD \pm) ⁽²⁾	6	30		70	ns
t_{HON}	CD Heartbeat Delay (TX \pm to CD \pm)	6	0.6		1.6	μ s
t_{HW}	CD Heartbeat Duration (CD \pm)	6	0.5	1.0	1.5	μ s

NOTES

1. All typicals are given for $T_A = 25^\circ C$, $V_{CC} = 5V$.
2. As required to meet ANSI/IEEE 802.3 and ISO 8802-3 specifications.

SEEQ TECHNOLOGY INC

Timing and Load Diagrams

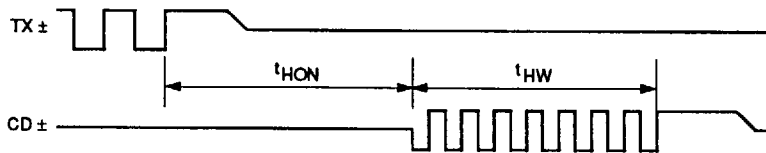

Figure 6. Heartbeat Timing

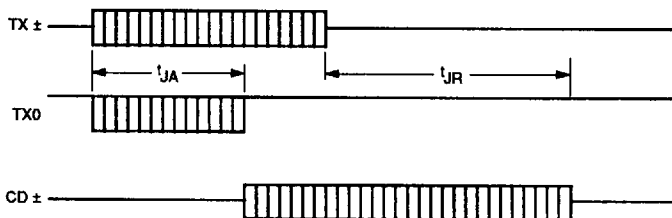

Figure 7. Jabber Timing

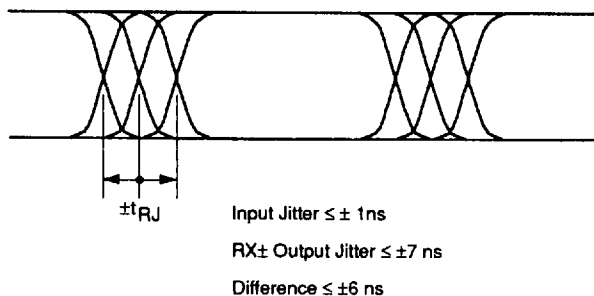

Figure 8. Receive Jitter Timing

Ordering Information

EM2 — Ether Module for 10Base-2 with HBE Enabled

EM2R — Ether Module for 10Base-2 with HBE Function Selectable