

**PACKAGE DIMENSIONS**

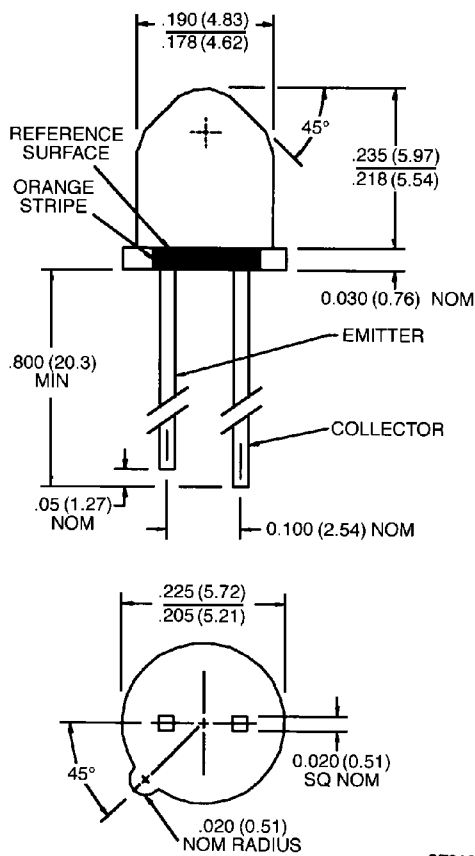

**DESCRIPTION**

The QSD733 is a silicon photodarlington encapsulated in an infrared transparent, black TO-18 package.

**FEATURES**

- Steel lead frames for improved reliability in solder mounting.
- Good optical-to-mechanical alignment.
- Narrow reception angle.
- Plastic package is infrared transparent black to attenuate visible light.
- Mechanically and spectrally matched to the QED523 LED.
- Black plastic body allows easy recognition from LED.

ST2147

NOTES:

1. DIMENSIONS ARE IN INCHES (mm).
2. TOLERANCE IS  $\pm .010 (.25)$  UNLESS OTHERWISE SPECIFIED.
3. TAB DENOTES EMITTER.



## PLASTIC SILICON PHOTODARLINGTON

<b>ABSOLUTE MAXIMUM RATINGS</b> ( $T_A = 25^\circ\text{C}$ Unless Otherwise Specified)	
Storage Temperature .....	-40°C to + 100°C
Operating Temperature .....	-40°C to + 100°C
Soldering:	
Lead Temperature (Iron) .....	240°C for 5 sec. <sup>(2,3,4,5)</sup>
Lead Temperature (Flow) .....	260°C for 10 sec. <sup>(2,3,5)</sup>
Collector-Emitter Breakdown Voltage .....	30 Volts
Emitter-Collector Breakdown Voltage .....	5.0 Volts
Power Dissipation .....	100 mW <sup>(1)</sup>

<b>ELECTRICAL CHARACTERISTICS</b> ( $T_A = 25^\circ\text{C}$ Unless Otherwise Specified) (All measurements made under pulse conditions.)						
PARAMETER	SYMBOL	MIN.	TYP.	MAX.	UNITS	TEST CONDITIONS
Collector-Emitter Breakdown	$BV_{CEO}$	30	—	—	V	$I_C = 1.0\text{ mA}$
Emitter-Collector Breakdown	$BV_{ECO}$	5.0	—	—	V	$I_E = 100\ \mu\text{A}$
Collector-Emitter Leakage	$I_{CEO}$	—	—	100	nA	$V_{CE} = 10\text{ V}$
Reception Angle at ½ Sensitivity	$\theta$	—	±20	—	Degrees	
On-State Collector Current	$I_{C(ON)}$	5.0	—	—	mA	$E_e = 0.125\text{ mW/cm}^2$ , $V_{CE} = 5\text{V}^{(6)}$
Saturation Voltage	$V_{CE(SAT)}$	—	—	1.0	V	$I_C = 2.0\text{ mA}$ , $E_e = 0.125\text{ mW/cm}^2^{(6)}$
Rise Time	$t_r$	—	20	—	$\mu\text{S}$	$I_C = .15\text{ mA}$ , $V_{CC} = 5\text{V}$ , $R_L = 100\ \Omega$
Fall Time	$t_f$	—	50	—	$\mu\text{S}$	$I_C = .15\text{ mA}$ , $V_{CC} = 5\text{V}$ , $R_L = 100\ \Omega$

<b>NOTES</b>
1. Derate power dissipation linearly 1.33 mW/°C above 25°C.
2. RMA flux is recommended.
3. Methanol or Isopropyl alcohols are recommended as cleaning agents.
4. Soldering iron tip 1/16" (1.6 mm) minimum from housing.
5. As long as leads are not under any stress or spring tension.
6. Light source is an AlGaAs LED emitting light at a peak wavelength of 880 nm.