



**HEWLETT  
PACKARD**

## HERMETIC, NUMERIC AND HEXADECIMAL DISPLAYS FOR MILITARY APPLICATIONS

<b>HIGH EFFICIENCY RED</b>	
Low Power	HDSP-078X/078XTXV/078TXVB
High Brightness	HDSP-079X/079XTXV/079TXVB
<b>YELLOW</b>	HDSP-088X/088XTXV/088TXVB
<b>HIGH PERFORMANCE GREEN</b>	HDSP-098X/098XTXV/098TXVB

### Features

- CONFORM TO MIL-D-87157, QUALITY LEVEL A TEST TABLES
- TRUE HERMETIC PACKAGE FOR HIGH EFFICIENCY RED AND YELLOW<sup>(1)</sup>
- TXV AND TXVB VERSIONS AVAILABLE
- THREE CHARACTER OPTIONS  
Numeric, Hexadecimal, Over Range
- THREE COLORS  
High Efficiency Red, Yellow,  
High Performance Green
- 4 x 7 DOT MATRIX CHARACTER
- HIGH EFFICIENCY RED, YELLOW, AND HIGH PERFORMANCE GREEN
- TWO HIGH EFFICIENCY RED OPTIONS  
Low Power, High Brightness
- PERFORMANCE GUARANTEED OVER TEMPERATURE
- HIGH TEMPERATURE STABILIZED
- GOLD PLATED LEADS
- MEMORY LATCH/DECODER/DRIVER  
TTL Compatible
- CATEGORIZED FOR LUMINOUS INTENSITY

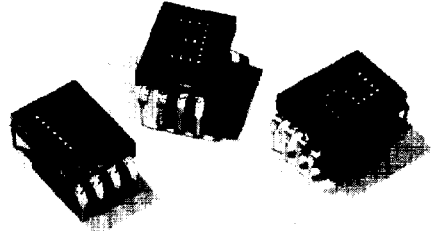

The hermetic HDSP-078X,-079X/-088X displays utilize a solder glass frit seal. The HDSP-098X displays utilize an epoxy glass-to-ceramic seal. All packages conform to the hermeticity requirements of MIL-D-87157, the general specification for LED displays. These displays are designed for use in military and aerospace applications.

The numeric devices decode positive BCD logic into characters "0-9", a "--" sign, decimal point, and a test pattern. The hexadecimal devices decode positive BCD logic into 16 characters, "0-9, A-F". An input is provided on the hexadecimal devices to blank the display (all LEDs off) without losing the contents of the memory.

The over range device displays "±1" and right hand decimal point and is typically driven via external switching transistors.

**Note:**

1. The HDSP-098X high performance green displays are epoxy sealed and conform to MIL-D-87157 hermeticity requirements.

### Description

These solid state displays have a 7.4mm (0.29 inch) dot matrix character and an onboard IC with data memory latch/decoder and LED drivers in a glass/ceramic package.

### Devices

Part Number HDSP-	Color	Description	Front View
0781/0781TXV/0781TXVB 0782/0782TXV/0782TXVB 0783/0783TXV/0783TXVB 0784/0784TXV/0784TXVB	High-Efficiency Red Low Power	Numeric, Right Hand DP Numeric, Left Hand DP Over Range ±1 Hexadecimal	A B C D
0791/0791TXV/0791TXVB 0792/0792TXV/0792TXVB 0783/0783TXV/0783TXVB 0794/0794TXV/0794TXVB	High-Efficiency Red High Brightness	Numeric, Right Hand DP Numeric, Left Hand DP Over Range ±1 Hexadecimal	A B C D
0881/0881TXV/0881TXVB 0882/0882TXV/0882TXVB 0883/0883TXV/0883TXVB 0884/0884TXV/0884TXVB	Yellow	Numeric, Right Hand DP Numeric, Left Hand DP Over Range ±1 Hexadecimal	A B C D
0981/0981TXV/0981TXVB 0982/0982TXV/0982TXVB 0983/0983TXV/0983TXVB 0984/0984TXV/0984TXVB	High Performance Green	Numeric, Right Hand DP Numeric, Left Hand DP Over Range ±1 Hexadecimal	A B C D

HERMETIC  
DISPLAYS

# Package Dimensions

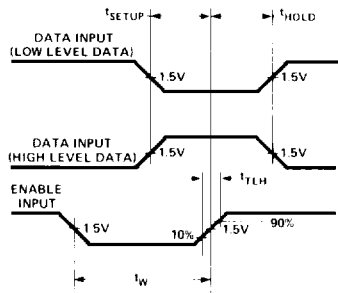
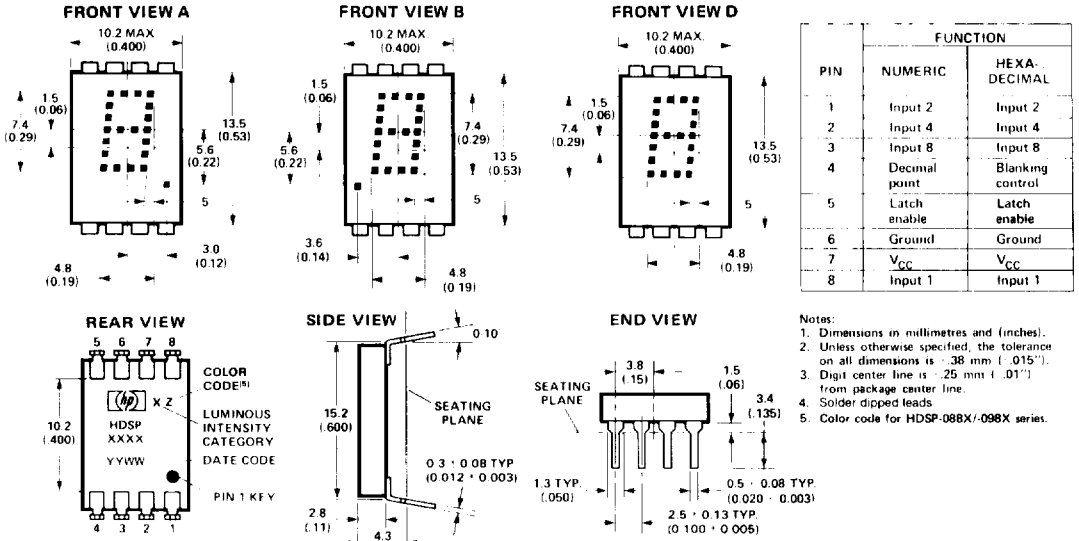

Figure 1. Timing Diagram

BCD DATA <sup>(1)</sup>				TRUTH TABLE	
X <sub>8</sub>	X <sub>4</sub>	X <sub>2</sub>	X <sub>1</sub>	NUMERIC	HEXA-DECIMAL
L	L	L	L	0	0
L	L	L	H	1	1
L	L	H	L	2	2
L	L	H	H	3	3
L	H	L	L	4	4
L	H	L	H	5	5
L	H	H	L	6	6
L	H	H	H	7	7
H	L	L	L	8	8
H	L	L	H	9	9
H	L	H	L	(BLANK)	(BLANK)
H	L	H	H	(BLANK)	(BLANK)
H	H	L	L	(BLANK)	(BLANK)
H	H	L	H	(BLANK)	(BLANK)
H	H	H	L	(BLANK)	(BLANK)
H	H	H	H	(BLANK)	(BLANK)
DECIMAL PT <sup>(2)</sup>				ON	V <sub>DP</sub> = L
DECIMAL PT <sup>(2)</sup>				OFF	V <sub>DP</sub> = H
ENABLE <sup>(1)</sup>				LOAD DATA	V <sub>I</sub> = L
ENABLE <sup>(1)</sup>				LATCH DATA	V <sub>I</sub> = H
BLANKING <sup>(3)</sup>				DISPLAY ON	V <sub>B</sub> = L
BLANKING <sup>(3)</sup>				DISPLAY OFF	V <sub>B</sub> = H

- Notes:  
 1. H = Logic High; L = Logic Low. With the enable input at logic high changes in BCD input logic levels have no effect upon display memory, displayed character, or DP.  
 2. The decimal point input, DP, pertains only to the numeric displays.  
 3. The blanking control input, B, pertains only to the hexadecimal displays. Blanking input has no effect upon display memory.

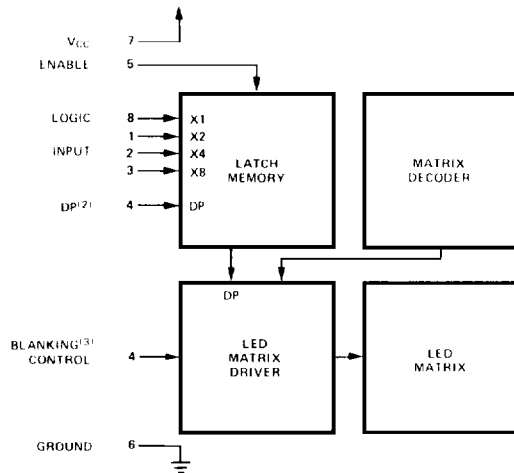

Figure 2. Logic Block Diagram

## Absolute Maximum Ratings

Description	Symbol	Min.	Max.	Unit
Storage temperature, ambient HDSP-078X/-079X/-088X	T <sub>S</sub>	-65	+125	°C
HDSP-098X		-55	+100	
Operating temperature, ambient <sup>[1]</sup>	T <sub>A</sub>	-55	+100	°C
Supply voltage <sup>[2]</sup>	V <sub>CC</sub>	-0.5	+7.0	V
Voltage applied to input logic, dp and enable pins	V <sub>I</sub> , V <sub>DP</sub> , V <sub>E</sub>	-0.5	V <sub>CC</sub>	V
Voltage applied to blanking input <sup>[2]</sup>	V <sub>R</sub>	-0.5	V <sub>CC</sub>	V
Maximum solder temperature at 1.59 mm (0.062 inch) below seating plane: t : 5 seconds			260	°C

## Recommended Operating Conditions

Description	Symbol	Min.	Nom.	Max.	Unit
Supply Voltage <sup>2</sup>	V <sub>CC</sub>	4.5	5.0	5.5	V
Operating temperature, ambient <sup>1</sup>	T <sub>A</sub>	-55		+100	°C
Enable Pulse Width	t <sub>w</sub>	100			nsec
Time data must be held before positive transition of enable line	t <sub>STUP</sub>	50			nsec
Time data must be held after positive transition of enable line	t <sub>HOUD</sub>	50			nsec
Enable pulse rise time	t <sub>RISE</sub>			1.0	msec

## Optical Characteristics at T<sub>A</sub> = 25°C, V<sub>CC</sub> = 5.0V

Device	Description	Symbol	Min.	Typ.	Max.	Unit
HDSP-078X Series	Luminous Intensity per LED (Digit Average) <sup>[3,4]</sup>	I <sub>V</sub>	65	140		μcd
	Peak Wavelength	λ <sub>PEAK</sub>		635		nm
	Dominant Wavelength <sup>[5]</sup>	λ <sub>d</sub>		626		nm
HDSP-079X Series	Luminous Intensity per LED (Digit Average) <sup>[3,4]</sup>	I <sub>V</sub>	260	620		μcd
	Peak Wavelength	λ <sub>PEAK</sub>		635		nm
	Dominant Wavelength <sup>[5]</sup>	λ <sub>d</sub>		626		nm
HDSP-088X Series	Luminous Intensity per LED (Digit Average) <sup>[3,4]</sup>	I <sub>V</sub>	215	490		μcd
	Peak Wavelength	λ <sub>PEAK</sub>		583		nm
	Dominant Wavelength <sup>[5,6]</sup>	λ <sub>d</sub>		585		nm
HDSP-098X Series	Luminous Intensity per LED (Digit Average) <sup>[3,4]</sup>	I <sub>V</sub>	298	1100		μcd
	Peak Wavelength	λ <sub>PEAK</sub>		568		nm
	Dominant Wavelength	λ <sub>d</sub>		574		nm

### Notes:

- The nominal thermal resistance of a display mounted in a socket that is soldered onto a printed circuit board is R<sub>θJA</sub> = 50° C/W/device. The device package thermal resistance is R<sub>θJ PIN</sub> = 15° C/W/device. The thermal resistance device pin-to-ambient through the PC board should not exceed 35° C/W/device for operation at T<sub>A</sub> = +100° C.
- Voltage values are with respect to device ground, pin 6.
- These displays are categorized for luminous intensity with the intensity category designated by a letter code located on the back of the display package. Case temperature of the device immediately prior to the light measurement is equal to 25° C.

## Electrical Characteristics; ( $T_A = -55^\circ\text{C}$ to $+100^\circ\text{C}$ )

Description	Symbol	Test Conditions	Min.	Typ.[7]	Max.	Unit
Supply Current HDSP-078X Series HDSP-079X/-088X/ -098X Series	I <sub>CC</sub>	V <sub>CC</sub> = 5.5 V Characters "5." or "B" displayed		78 120	105 175	mA
Power Dissipation HDSP-078X Series HDSP-079X/-088X/ -098X Series	P <sub>T</sub>	V <sub>CC</sub> = 5.5 V Characters "5." or "B" displayed		390 690	573 963	mW
Logic, Enable and Blanking Low-Level Input Voltage	V <sub>IL</sub>	V <sub>CC</sub> = 4.5 V			0.8	V
Logic, Enable High-Level Input Voltage	V <sub>IH</sub>		2.0			V
Blanking High Voltage; Display Blanked	V <sub>BH</sub>		2.3			V
Logic and Enable Low-Level Input Current	I <sub>IL</sub>	V <sub>CC</sub> = 5.5 V			-1.6	mA
Blanking Low-Level Input Current	I <sub>BL</sub>	V <sub>IL</sub> = 0.4 V			-10	μA
Logic, Enable and Blanking High-Level Input Current	I <sub>IH</sub>	V <sub>CC</sub> = 5.5 V V <sub>IH</sub> = 2.4 V			+40	μA
Weight				1.0		gm
Leak Rate					5 x 10 <sup>-8</sup>	cc/sec.

### Notes:

4. The luminous intensity at a specific operating ambient temperature,  $I_V(T_A)$  may be approximated from the following exponential equation:  $I_V(T_A) = I_V(25^\circ\text{C}) e^{(K)(T_A - 25^\circ\text{C})}$ .

Device	K
HDSP-078X Series HDSP-079X Series	0.0131/°C
HDSP-088X Series	-0.0112/°C
HDSP-098X Series	0.0104/°C

5. The dominant wavelength,  $\lambda_d$ , is derived from the CIE Chromaticity Diagram and is that single wavelength which defines the color of the device.
6. The HDSP-088X and HDSP-098X series devices are categorized as to dominant wavelength with the category designated by a number on the back side of the display package.
7. All typical values at V<sub>CC</sub> = 5.0 V and T<sub>A</sub> = 25°C.

## Operational Considerations

### ELECTRICAL

These devices use a modified 4 x 7 dot matrix of light emitting diodes to display decimal/hexadecimal numeric information. The high efficiency red and yellow displays use GaAsP/GaP LEDs and the high performance green displays use GaP/GaP LEDs. The LEDs are driven by constant current drivers. BCD information is accepted by the display memory when the enable line is at logic low and the data is latched when the enable is at logic high. Using the enable pulse width and data setup and hold times listed in the Recommended Operating Conditions allows data to be clocked into an array of displays at 6.7 MHz rate.

The decimal point input is active low true and this data is latched into the display memory in the same fashion as the BCD data. The decimal point LED is driven by the on-board IC.

The blanking control input on the hexadecimal displays blanks (turns off) the displayed information without disturbing the contents of display memory. The display is blanked at a minimum threshold level of 2.0 volts. When blanked, the display standby power is nominally 250 mW at T<sub>A</sub> = 25°C.

The ESD susceptibility of the IC devices is Class A of MIL-STD-883 or Class 2 of DOD-STD-1686 and DOD-HDBK-263.

### MECHANICAL

These displays are hermetically sealed for use in environments that require a high reliability device. These displays are designed and tested to meet a helium leak rate of 5 x 10<sup>-8</sup> cc/sec.

These displays may be mounted by soldering directly to a printed circuit board or insertion into a socket. The lead-to-lead pin spacing is 2.54 mm (0.100 inch) and the lead row spacing is 15.24 mm (0.600 inch). These displays may be end stacked with 2.54 mm (0.100 inch) spacing between outside pins of adjacent displays. Sockets such as Augat 324-AG2D (3 digits) or Augat 508-AG8D (one digit, right angle mounting) may be used.

The primary thermal path for power dissipation is through the device leads. Therefore, to insure reliable operation up to an ambient temperature of +100°C, it is important to maintain a base-to-ambient thermal resistance of less than 35°C watt/device as measured on top of display pin 3.

Post solder cleaning may be accomplished using water, Freon/alcohol mixtures formulated for vapor cleaning processing (up to 2 minutes in vapors at boiling) or Freon/alcohol mixtures formulated for room temperature cleaning. Suggested solvents: Freon TF, Freon TE, Genesolv DI-15, Genesolv DE-15.

## PRECONDITIONING

These displays are 100% preconditioned by 24 hour storage at 125°C, at 100°C for the HDSP-098X Series.

## CONTRAST ENHANCEMENT

These display devices are designed to provide an optimum ON/OFF contrast when placed behind an appropriate contrast enhancement filter. The following filters are suggested:

Display Color	Ambient Lighting		
	Dim	Moderate	Bright
HDSP-088X Yellow	Panelgraphic Yellow 27 Chequers Amber 107	Polaroid HNCP 37 3M Light Control Film  Panelgraphic Gray 10	Polaroid Gray HNCP10 HOYA Yellowish-Orange HLF-608-3Y Marks Gray MCP-0301-8-10
HDSP-078X/-079X HER	Panelgraphic Ruby Red 60 Chequers Red 112	Chequers Grey 105	Polaroid Gray HNCP10 HOYA Reddish-Orange HLF-608-5R Marks Gray MCP-0301-8-10 Marks Reddish-Orange MCP-0201-2-22
HDSP-098X HP Green	Panelgraphic Green 48 Chequers Green 107		Polaroid Gray HNCP10 HOYA Yellow-Green HLF-608-1G Marks Yellow-Green MCP-0101-5-12

## Over Range Display

The over range devices display "±1" and decimal point. The character height and package configuration are the same as the numeric and hexadecimal devices. Character selection is obtained via external switching transistors and current limiting resistors.

## Absolute Maximum Ratings

Description	Symbol	Min.	Max.	Unit
Storage Temperature, Ambient	T <sub>S</sub>	-65	+125	°C
Operating Temperature, Ambient	T <sub>A</sub>	-55	+100	°C
Forward Current, Each LED	I <sub>F</sub>		10	mA
Reverse Voltage, Each LED	V <sub>R</sub>		5	V

Character	Pin			
	1	2,3	4	8
-	1	X	X	1
0	0	X	X	1
1	X	1	X	X
Decimal Point	X	X	1	X
Blank	0	0	0	0

Notes  
 0: Line switching transistor in Figure 7 cutoff.  
 1: Line switching transistor in Figure 7 saturated.  
 X: 'don't care'

## Package Dimensions

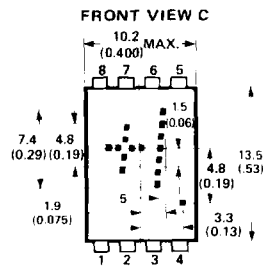

Pin	Function
1	Plus
2	Numeral One
3	Numeral One
4	DP
5	Open
6	Open
7	V <sub>CC</sub>
8	Minus/Plus

Note:  
 1. Dimensions in millimetres and inches.

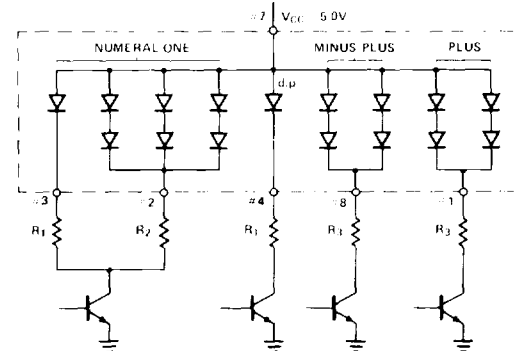

Figure 3. Typical Driving Circuit

HERMETIC  
DISPLAYS

## Luminous Intensity Per LED

Digit Average at  $T_A = 25^\circ\text{C}$

Device	Test Conditions	Min.	Typ.	Units
HDSP-0783	$I_F = 2.8\text{ mA}$	65	140	$\mu\text{cd}$
	$I_F = 8\text{ mA}$		620	$\mu\text{cd}$
HDSP-0883	$I_F = 8\text{ mA}$	215	490	$\mu\text{cd}$
HDSP-0983	$I_F = 8\text{ mA}$	298	1100	$\mu\text{cd}$

## Recommended Operating Conditions $V_{CC} = 5.0\text{V}$

Device	Forward Current Per LED, mA	Resistor Value			
		$R_1$	$R_2$	$R_3$	
HDSP-0783	Low Power	2.8	1300	200	300
	High Brightness	8	360	47	68
HDSP-0883	8	360	36	56	
HDSP-0983	8	360	30	43	

## Electrical Characteristics ( $T_A = -55^\circ\text{C}$ to $+100^\circ\text{C}$ )

Device	Description	Symbol	Test Condition	Min.	Typ.	Max.	Units
HDSP-0783	Power Dissipation (all LEDs illuminated)	$P_T$	$I_F = 2.8\text{ mA}$		72		mW
			$I_F = 8\text{ mA}$		224	282	
	Forward Voltage per LED	$V_F$	$I_F = 2.8\text{ mA}$		1.6		V
			$I_F = 8\text{ mA}$		1.75	2.2	
HDSP-0883	Power Dissipation (all LEDs illuminated)	$P_T$	$I_F = 8\text{ mA}$		237	282	mW
	Forward Voltage per LED	$V_F$			1.90	2.2	V
HDSP-0983	Power Dissipation (all LEDs illuminated)	$P_T$	$I_F = 8\text{ mA}$		243	282	mW
	Forward Voltage per LED	$V_F$			1.85	2.2	V

## High Reliability Testing

Two standard reliability testing programs are available. The TXVB program is in conformance with Quality Level A Test Tables of MIL-D-87157 for hermetically sealed displays with 100% screening tests. A TXVB product is tested to Tables I, II, IIIa, and IVa. A second program is an HP modification to the full conformance program and offers the 100% screening portion of Level A, Table I, and Group A, Table II.

### PART MARKING SYSTEM

Standard Product	With Table I and II	With Tables I, II, IIIa and IVa
HDSP-078X	HDSP-078XTXV	HDSP-078XTXVB
HDSP-079X	HDSP-079XTXV	HDSP-079XTXVB
HDSP-088X	HDSP-088XTXV	HDSP-088XTXVB
HDSP-098X	HDSP-098XTXV	HDSP-098XTXVB

### 100% Screening

TABLE I. QUALITY LEVEL A OF MIL-D-87157

Test Screen	MIL-STD-750 Method	Conditions
1. Precap Visual	2072	Interpreted by HP Procedure 5956-7572-52
2. High Temperature Storage	1032	$T_A = 125^\circ\text{C}$ , Time = 24 hours <sup>[4]</sup>
3. Temperature Cycling	1051	Condition B, 10 Cycles, 15 Min. Dwell
4. Constant Acceleration	2006	10,000 G at $Y_1$ orientation
5. Fine Leak	1071	Condition H
6. Gross Leak	1071	Condition C or K <sup>[5]</sup>
7. Interim Electrical/Optical Tests <sup>2</sup>	—	$I_V, I_{CC}, I_{BL}, I_{BH}, I_{EL}, I_{EH}, I_{IL},$ and $I_{IH}$ $T_A = 25^\circ\text{C}$
8. Burn-In <sup>1,3</sup>	1015	Condition B at $V_{CC} = 5\text{V}$ and cycle through logic at 1 character per second. $T_A = 100^\circ\text{C}$ , $t = 160$ hours
9. Final Electrical Test <sup>2</sup>	—	Same as Step 7
10. Delta Determinations	—	$\Delta I_V = -20\%$ , $\Delta I_{CC} = +10\text{ mA}$ , $\Delta I_{IH} = +10\text{ }\mu\text{A}$ and $\Delta I_{EH} = +13\text{ }\mu\text{A}$
11. External Visual <sup>1</sup>	2009	

#### Notes:

- MIL-STD-883 Test Method applies
- Limits and conditions are per the electrical/optical characteristics
- Burn-in for the over range display shall use Condition B at a nominal  $I_F = 8\text{ mA}$  per LED, with all LEDs illuminated for  $T = 160$  hours minimum.
- $T_A = +100^\circ\text{C}$  for HDSP-098X Series
- Fluid temperature =  $+100^\circ\text{C}$  for HDSP-098X Series.

**TABLE II  
GROUP A ELECTRICAL TESTS — MIL-D-87157**

Test	Parameters	LTPD
<b>Subgroup 1</b> DC Electrical Tests at 25°C <sup>1</sup>	I <sub>V</sub> , I <sub>CC</sub> , I <sub>BL</sub> , I <sub>BH</sub> , I <sub>EL</sub> , I <sub>EH</sub> , I <sub>IL</sub> , and I <sub>IH</sub> and visual function, T <sub>A</sub> = 25°C	5
<b>Subgroup 2</b> DC Electrical Tests at High Temperature <sup>1</sup>	Same as Subgroup 1, except delete I <sub>V</sub> and visual function, T <sub>A</sub> = +100°C	7
<b>Subgroup 3</b> DC Electrical Tests at Low Temperature <sup>1</sup>	Same as Subgroup 1, except delete I <sub>V</sub> and visual function, T <sub>A</sub> = -55°C	7
<b>Subgroup 4, 5, and 6 not applicable</b>		
<b>Subgroup 7</b> Optical and Functional Tests at 25°C	Satisfied by Subgroup 1	5
<b>Subgroup 8</b> External Visual	MIL-STD-883, Method 2009	7

**Notes:**

1. Limits and conditions are per the electrical/optical characteristics.

**TABLE IIIa  
GROUP B, CLASS A AND B OF MIL-D-87157**

Test	MIL-STD-750 Method	Conditions	Sample Size
<b>Subgroup 1</b> Resistance to Solvents	1022		4 Devices/ 0 Failures
Internal Visual and Design Verification <sup>[1]</sup>	2075 <sup>[7]</sup>		1 Device/ 0 Failures
<b>Subgroup 2<sup>[2,3]</sup></b> Solderability	2026	T <sub>A</sub> = 245°C for 5 seconds	LTPD = 15
<b>Subgroup 3</b> Thermal Shock : Temp. Cycle :	1051	Condition B1, 15 min. Dwell	LTPD = 15
Moisture Resistance <sup>[4]</sup>	1021		
Fine Leak	1071	Condition H	
Gross Leak	1071	Condition C or K <sup>[9]</sup>	
Electrical/Optical Endpoints <sup>[5]</sup>	—	I <sub>V</sub> , I <sub>CC</sub> , I <sub>BL</sub> , I <sub>BH</sub> , I <sub>EL</sub> , I <sub>EH</sub> , I <sub>IL</sub> , I <sub>IH</sub> and visual function, T <sub>A</sub> = 25°C	
<b>Subgroup 4</b> Operating Life Test (340 hrs.) <sup>[6]</sup>	1027	T <sub>A</sub> = +100°C at V <sub>CC</sub> = 5.0V and cycling through logic at 1 character per second.	LTPD = 10
Electrical/Optical Endpoints <sup>[5]</sup>	—	Same as Subgroup 3.	
<b>Subgroup 5</b> Non-operating : Storage : Life Test : 340 hrs.)	1032	T <sub>A</sub> = +125°C <sup>[7,8]</sup>	LTPD = 10
Electrical/Optical Endpoints <sup>[5]</sup>	—	Same as Subgroup 3	

**Notes:**

1. Visual inspection performed through the display window
2. Whenever electrical/optical tests are not required as endpoints, electrical rejects may be used
3. The LTPD applies to the number of leads inspected except in no case shall less than 3 displays be used to provide the number of leads required.
4. Initial conditioning is a 15° inward bend, one cycle.
5. Limits and conditions are per the electrical/optical characteristics
6. Burn-in for the over range display shall use Condition B at a nominal I<sub>F</sub> ± 8 mA with '+' illuminated for t = 160 hours.
7. Equivalent to MIL-STD-883, Method 2014.
8. T<sub>A</sub> = +100°C for HDSP-098X Series.
9. Fluid temperature = +100°C for HDSP-098X Series.

HERMETIC DISPLAYS

**TABLE IVa**  
**GROUP C, CLASS A AND B OF MIL-D-87157**

Test	MIL-STD-750 Method	Conditions	Sample Size
<b>Subgroup 1</b> Physical Dimensions	2066		2 Devices/ 0 Failures
<b>Subgroup 2<sup>(2,7,9)</sup></b> Lead Integrity	2004	Condition B2	LTPD = 15
Fine Leak	1071	Condition H	
Gross Leak	1071	Condition C or K <sup>(10)</sup>	
<b>Subgroup 3</b> Shock	2016	1500G, Time = 0.5 ms, 5 blows in each orientation X <sub>1</sub> , Y <sub>1</sub> , Z <sub>1</sub>	LTPD = 15
Vibration, Variable Frequency	2056		
Constant Acceleration	2006	10,000G at Y <sub>1</sub> orientation	
External Visual <sup>4</sup>	1010 or 1011		
Electrical/Optical Endpoints <sup>8</sup>	—	Iv, Icc, IBL, IBH, IEL, IEH, IIL, IIH and visual Function, T <sub>A</sub> = 25°C	
<b>Subgroup 4<sup>(1,3)</sup></b> Salt Atmosphere	1041		LTPD = 15
External Visual <sup>4</sup>	1010 or 1011		
<b>Subgroup 5</b> Bond Strength <sup>(5)</sup>	2037	Condition A	LTPD = 20 (C = 0)
<b>Subgroup 6</b> Operating Life Test <sup>6</sup>	1026	T <sub>A</sub> = +100°C	λ = 10
Electrical/Optical Endpoints <sup>8</sup>	—	Same as Subgroup 3	

**Notes:**

1. Whenever electrical/optical tests are not required as endpoints, electrical rejects may be used.
2. The LTPD applies to the number of leads inspected except in no case shall less than three displays be used to provide the number of leads required.
3. Solderability samples shall not be used.
4. Visual requirements shall be as specified in MIL-STD-883, Methods 1010 or 1011.
5. Displays may be selected prior to seal.
6. If a given inspection lot undergoing Group B inspection has been selected to satisfy Group C inspection requirements, the 340 hour life tests may be continued on test to 1000 hours in order to satisfy the Group C Life Test requirements. In such cases, either the 340 hour endpoint measurements shall be made a basis for Group B lot acceptance or the 1000 hour endpoint measurement shall be used as the basis for both Group B and Group C acceptance.
7. MIL-STD-883 test method applies.
8. Limits and conditions are per the electrical/optical characteristics.
9. Initial conditioning is a 15° inward bend, 3 cycles
10. Fluid temperature = +100°C for HDSP-098X Series.