

SMJ320C30 DIGITAL SIGNAL PROCESSOR

SGUS014C - FEBRUARY 1991 - REVISED MARCH 1998

- -55°C to 125°C Operating Temperature Range, QML Processing
- Processed to MIL-PRF-38535 (QML)
- Performance
 - SMJ320C30-33 (60-ns Cycle)
33 Million Floating-Point Operations per Second (MFLOPS)
16.7 Million Instructions Per Second (MIPS)
 - SMJ320C30-40 (50-ns Cycle)
40 MFLOPS
20 MIPS
 - SMJ320C30-50 (40-ns Cycle)
50 MFLOPS
25 MIPS
- Two 1K-Word × 32-Bit Single-Cycle Dual-Access On-Chip RAM Blocks
- Validated Ada Compiler
- 64-Word × 32-Bit Instruction Cache
- 32-Bit Instruction and Data Words, 24-Bit Addresses
- 40/32-Bit Floating-Point/Integer Multiplier and Arithmetic Logic Unit (ALU)
- Parallel ALU and Multiplier Execution in a Single Cycle
- On-Chip Direct Memory Access (DMA) Controller for Concurrent I/O and CPU Operation
- Integer, Floating-Point, and Logical Operations
- One 4K-Word × 32-Bit Single-Cycle Dual-Access On-Chip ROM Block
- Two 32-Bit External Ports (24- and 13-Bit Address)
- Two Serial Ports With Support for 8-/16-/24-/32-Bit Transfers
- Packaging
 - 181-Pin Grid Array Ceramic Package (GB Suffix)
 - 196-Pin Ceramic Quad Flatpack With Nonconductive Tie-Bar (HFG Suffix)
- SMD Approval for 33-, 40-, and 50-MHz Versions
- Two Address Generators With Eight Auxiliary Registers and Two Auxiliary Register Arithmetic Units (ARAUs)
- Zero-Overhead Loops With Single-Cycle Branches
- Interlocked Instructions for Multiprocessing Support
- 32-Bit Barrel Shifter
- Eight Extended-Precision Registers (Accumulators)
- Two- and Three-Operand Instructions
- Conditional Calls and Returns
- Block Repeat Capability
- Fabricated Using Enhanced Performance Implanted CMOS (EPIC™) by Texas Instruments (TI™)
- Two 32-Bit Timers

description

The SMJ320C30 internal busing and special digital signal processor (DSP) instruction set has the speed and flexibility to execute up to 50 MFLOPS. The SMJ320C30 device optimizes speed by implementing functions in hardware that other processors implement through software or microcode. This hardware-intensive approach provides performance previously unavailable on a single chip. The emphasis on total system cost has resulted in a less expensive processor that can be designed into systems currently using costly bit-slice processors.

- SMJ320C30-33: 60-ns single-cycle execution time, 10% supply
- SMJ320C30-40: 50-ns single-cycle execution time, 5% supply
- SMJ320C30-50: 40-ns single-cycle execution time, 5% supply



Please be aware that an important notice concerning availability, standard warranty, and use in critical applications of Texas Instruments semiconductor products and disclaimers thereto appears at the end of this data sheet.

EPIC and TI are trademarks of Texas Instruments Incorporated.

PRODUCTION DATA information is current as of publication date. Products conform to specifications per the terms of Texas Instruments standard warranty. Production processing does not necessarily include testing of all parameters.

 **TEXAS
INSTRUMENTS**

POST OFFICE BOX 1443 • HOUSTON, TEXAS 77251-1443

Copyright © 1998, Texas Instruments Incorporated
On products compliant to MIL-PRF-38535, all parameters are tested unless otherwise noted. On all other products, production processing does not necessarily include testing of all parameters.

TXIIS00759

SMJ320C30 DIGITAL SIGNAL PROCESSOR

SGUS014C – FEBRUARY 1991 – REVISED MARCH 1998

181-Pin GB Grid Array Package
(BOTTOM VIEW)

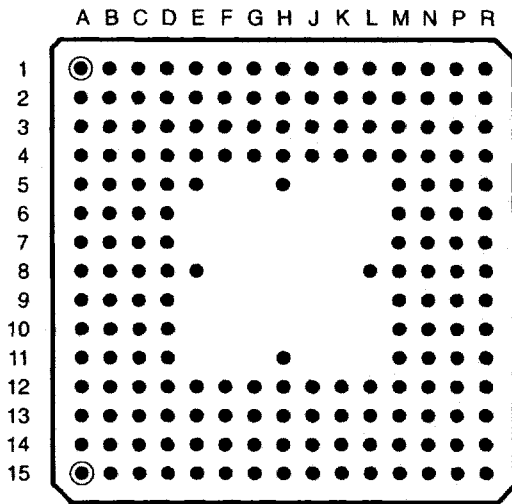

196-Pin HFG Quad Flatpack
(TOP VIEW)

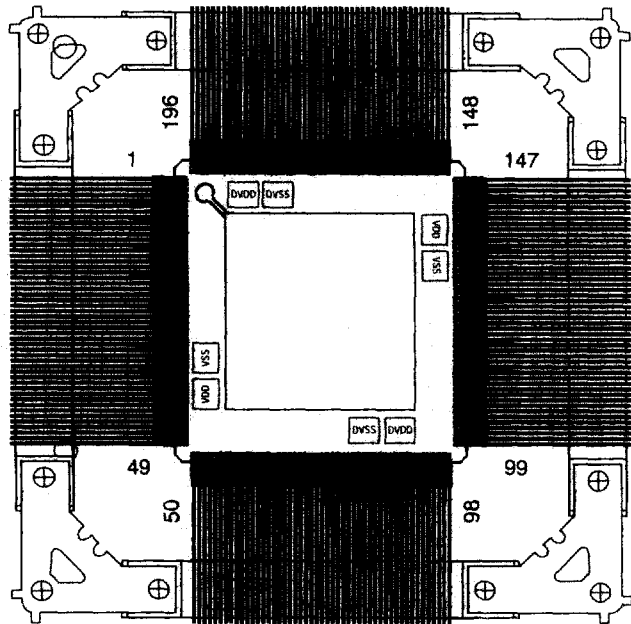

description (continued)

The SMJ320C30 can perform parallel multiply and ALU operations on integer or floating-point data in a single cycle. Each processor also possesses a general-purpose register file, a program cache, dedicated ARAUs, internal dual-access memories, one DMA channel supporting concurrent I/O, and a short machine-cycle time. High performance and ease of use are results of these features.

General-purpose applications are enhanced by the large address space, multiprocessor interface, internally and externally generated wait states, two external interface ports, two timers, two serial ports, and multiple interrupt structure. The SMJ320C30 supports a wide variety of system applications from host processor to dedicated coprocessor.

High-level language support is implemented easily through a register-based architecture, large address space, powerful addressing modes, flexible instruction set, and well-supported floating-point arithmetic.



POST OFFICE BOX 1443 • HOUSTON, TEXAS 77251-1443

SMJ320C30 DIGITAL SIGNAL PROCESSOR

SGUS014C - FEBRUARY 1991 - REVISED MARCH 1998

functional block diagram

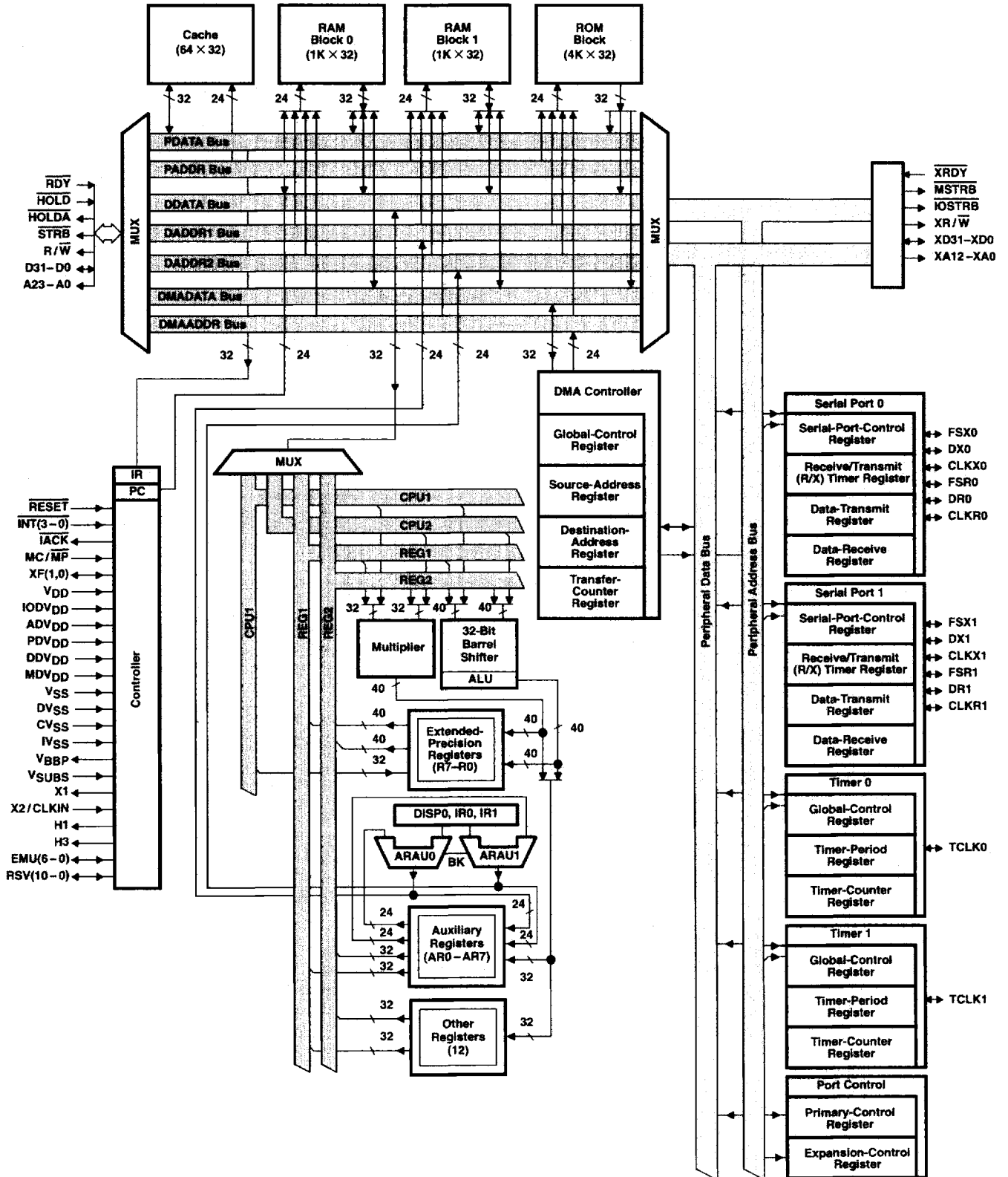

SMJ320C30 DIGITAL SIGNAL PROCESSOR

SGUS014C – FEBRUARY 1991 – REVISED MARCH 1998

memory map

Figure 1 shows the memory map for the SMJ320C30. See the *TMS320C3x User's Guide* (literature number SPRU031) for a detailed description of this memory mapping. Figure 2 shows the reset, interrupt, and trap vector/branches memory-map locations. Figure 3 shows the peripheral bus memory-mapped registers.

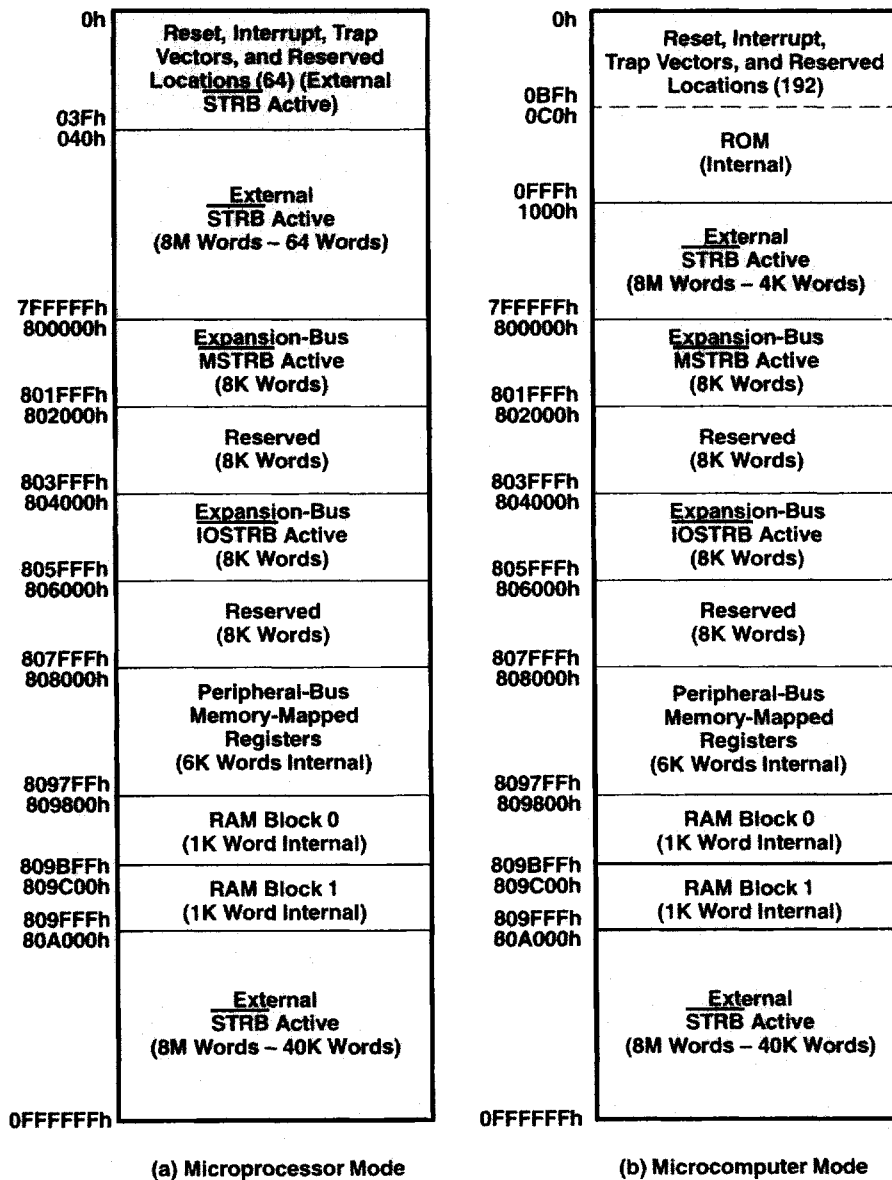

Figure 1. Memory Map



memory map (continued)

00h	Reset
01h	$\overline{\text{INT0}}$
02h	$\overline{\text{INT1}}$
03h	$\overline{\text{INT2}}$
04h	$\overline{\text{INT3}}$
05h	XINT0
06h	RINT0
07h	XINT1
08h	RINT1
09h	TINT0
0Ah	TINT1
0Bh	DINT
0Ch	Reserved
1Fh	
20h	TRAP 0
	.
	.
	.
3Bh	TRAP 27
3Ch	Reserved
3Fh	

(a) Microprocessor Mode

00h	Reset
01h	$\overline{\text{INT0}}$
02h	$\overline{\text{INT1}}$
03h	$\overline{\text{INT2}}$
04h	$\overline{\text{INT3}}$
05h	XINT0
06h	RINT0
07h	XINT1
08h	RINT1
09h	TINT0
0Ah	TINT1
0Bh	DINT
0Ch	Reserved
1Fh	
20h	TRAP 0
	.
	.
	.
3Bh	TRAP 27
3Ch	Reserved
BFh	

(a) Microcomputer Mode

Figure 2. Reset, Interrupt, and Trap Vector/Branches Memory-Map Locations

SMJ320C30 DIGITAL SIGNAL PROCESSOR

SGUS014C – FEBRUARY 1991 – REVISED MARCH 1998

memory map (continued)

808000h	DMA Global Control
808004h	DMA Source Address
808006h	DMA Destination Address
808008h	DMA Transfer Counter
808020h	Timer 0 Global Control
808024h	Timer 0 Counter
808028h	Timer 0 Period
808030h	Timer 1 Global Control
808034h	Timer 1 Counter
808038h	Timer 1 Period Register
808040h	Serial Port 0 Global Control
808042h	FSX/DX/CLKX Serial Port 0 Control
808043h	FSR/DR/CLKR Serial Port 0 Control
808044h	Serial Port 0 R/X Timer Control
808045h	Serial Port 0 R/X Timer Counter
808046h	Serial Port 0 R/X Timer Period
808048h	Serial Port 0 Data Transmit
80804Ch	Serial Port 0 Data Receive
808050h	Serial Port 1 Global Control
808052h	FSX/DX/CLKX Serial Port 1 Control
808053h	FSR/DR/CLKR Serial Port 1 Control
808054h	Serial Port 1 R/X Timer Control
808055h	Serial Port 1 R/X Timer Counter
808056h	Serial Port 1 R/X Timer Period
808058h	Serial Port 1 Data Transmit
80805Ch	Serial Port 1 Data Receive
808060h	Expansion-Bus Control
808064h	Primary-Bus Control

†Shading denotes reserved address locations

Figure 3. Peripheral Bus Memory-Mapped Registers†



SMJ320C30 DIGITAL SIGNAL PROCESSOR

SGUS014C – FEBRUARY 1991 – REVISED MARCH 1998

pin functions

This section gives signal descriptions for the SMJ320C30 devices in the microprocessor mode. The following tables list each signal, the number of pins, type of operating mode(s) (that is, input, output, or high-impedance state as indicated by I, O, or Z, respectively), and a brief function description. All pins labeled NC have special functions and should not be connected by the user. A line over a signal name (for example, $\overline{\text{RESET}}$) indicates that the signal is active low (true at logic-0 level). The signals are grouped according to functions.

Pin Functions

PIN NAME	QTY [‡]	TYPE [†]	DESCRIPTION	CONDITIONS WHEN SIGNAL IS Z TYPE [§]
PRIMARY BUS INTERFACE				
D31–D0	32	I/O/Z	32-bit data port of the primary bus interface	S H
A23–A0	24	O/Z	24-bit address port of the primary bus interface	S H R
$\overline{\text{R/W}}$	1	O/Z	Read/write for primary bus interface. $\overline{\text{R/W}}$ is high when a read is performed and low when a write is performed over the parallel interface.	S H R
$\overline{\text{STRB}}$	1	O/Z	External access strobe for the primary bus interface	S H
$\overline{\text{RDY}}$	1	I	Ready. $\overline{\text{RDY}}$ indicates that the external device is prepared for a primary bus interface transaction to complete.	
$\overline{\text{HOLD}}$	1	I	Hold for primary bus interface. When $\overline{\text{HOLD}}$ is a logic low, any ongoing transaction is completed. A23–A0, D31–D0, $\overline{\text{STRB}}$, and $\overline{\text{R/W}}$ are in the high-impedance state and all transactions over the primary bus interface are held until $\overline{\text{HOLD}}$ becomes a logic high or the NOHOLD bit of the primary bus control register is set.	
$\overline{\text{HOLDA}}$	1	O/Z	Hold acknowledge for primary bus interface. $\overline{\text{HOLDA}}$ is generated in response to a logic low on $\overline{\text{HOLD}}$. $\overline{\text{HOLDA}}$ indicates that A23–A0, D31–D0, $\overline{\text{STRB}}$, and $\overline{\text{R/W}}$ are in the high-impedance state and that all transactions over the bus are held. $\overline{\text{HOLDA}}$ is high in response to a logic high of $\overline{\text{HOLD}}$ or when the NOHOLD bit of the primary bus control register is set.	S
EXPANSION BUS INTERFACE				
XD31–XD0	32	I/O/Z	32-bit data port of the expansion bus interface	S R
XA12–XA0	13	O/Z	13-bit address port of the expansion bus interface	S R
$\overline{\text{XR/W}}$	1	O/Z	Read/write signal for expansion bus interface. When a read is performed, $\overline{\text{XR/W}}$ is held high; when a write is performed, $\overline{\text{XR/W}}$ is low.	S R
$\overline{\text{MSTRB}}$	1	O/Z	External memory access strobe for the expansion bus interface	S
$\overline{\text{IOSTRB}}$	1	O/Z	External I/O access strobe for the expansion bus interface	S
$\overline{\text{XRDY}}$	1	I	Ready signal. $\overline{\text{XRDY}}$ indicates that the external device is prepared for an expansion bus interface transaction to complete.	
CONTROL SIGNALS				
$\overline{\text{RESET}}$	1	I	Reset. When $\overline{\text{RESET}}$ is a logic low, the device is in the reset condition. When $\overline{\text{RESET}}$ becomes a logic high, execution begins from the location specified by the reset vector.	
$\overline{\text{INT3}}-\overline{\text{INT0}}$	4	I	External interrupts	
$\overline{\text{IACK}}$	1	O/Z	Interrupt acknowledge. $\overline{\text{IACK}}$ is set to a logic high by the IACK instruction. $\overline{\text{IACK}}$ can be used to indicate the beginning or end of an interrupt-service routine.	S
$\overline{\text{MC/MP}}$	1	I	Microcomputer/microprocessor mode	
XF1, XF0	2	I/O/Z	External flags. XF1 and XF0 are used as general-purpose I/Os or to support interlocked processor instructions.	S R

[†] I = input, O = output, Z = high-impedance state, NC = no connect

[‡] For GB package

[§] S = $\overline{\text{SHZ}}$ active, H = $\overline{\text{HOLD}}$ active, R = $\overline{\text{RESET}}$ active



SMJ320C30 DIGITAL SIGNAL PROCESSOR

SGUS014C – FEBRUARY 1991 – REVISED MARCH 1998

Pin Functions (Continued)

PIN NAME	QTY‡	TYPE†	DESCRIPTION	CONDITIONS WHEN SIGNAL IS Z TYPE§	
SERIAL PORT 0 SIGNALS					
CLKX0	1	I/O/Z	Serial port 0 transmit clock. CLKX0 is the serial-shift clock for the serial port 0 transmitter.	S	R
DX0	1	I/O/Z	Data transmit output. Serial port 0 transmits serial data on DX0.	S	R
FSX0	1	I/O/Z	Frame synchronization pulse for transmit. The FSX0 pulse initiates the transmit-data process over DX0.	S	R
CLKR0	1	I/O/Z	Serial port 0 receive clock. CLKR0 is the serial-shift clock for the serial port 0 receiver.	S	R
DR0	1	I/O/Z	Data receive. Serial port 0 receives serial data on DR0.	S	R
FSR0	1	I/O/Z	Frame synchronization pulse for receive. The FSR0 pulse initiates the receive-data process over DR0.	S	R
SERIAL PORT 1 SIGNALS					
CLKX1	1	I/O/Z	Serial port 1 transmit clock. CLKX1 is the serial-shift clock for the serial port 1 transmitter.	S	R
DX1	1	I/O/Z	Data transmit output. Serial port 1 transmits serial data on DX1.	S	R
FSX1	1	I/O/Z	Frame synchronization pulse for transmit. The FSX1 pulse initiates the transmit-data process over DX1.	S	R
CLKR1	1	I/O/Z	Serial port 1 receive clock. CLKR1 is the serial-shift clock for the serial port 1 receiver.	S	R
DR1	1	I/O/Z	Data receive. Serial port 1 receives serial data on DR1.	S	R
FSR1	1	I/O/Z	Frame synchronization pulse for receive. The FSR1 pulse initiates the receive-data process over DR1.	S	R
TIMER 0 SIGNALS					
TCLK0	1	I/O/Z	Timer clock 0. As an input, TCLK0 is used by timer 0 to count external pulses. As an output, TCLK0 outputs pulses generated by timer 0.	S	R
TIMER 1 SIGNALS					
TCLK1	1	I/O/Z	Timer clock 1. As an input, TCLK1 is used by timer 1 to count external pulses. As an output, TCLK1 outputs pulses generated by timer 1.	S	R
SUPPLY AND OSCILLATOR SIGNALS (see Note 1)					
VDD	4	I	5-V supply¶		
IODVDD	2	I	5-V supply¶		
ADVDD	2	I	5-V supply¶		
PDVDD	1	I	5-V supply¶		
DDVDD	2	I	5-V supply¶		
MDVDD	1	I	5-V supply¶		
VSS	4	I	Ground		
DVSS	4	I	Ground		
CVSS	2	I	Ground		

† I = input, O = output, Z = high-impedance state, NC = no connect

‡ For GB package

§ S = $\overline{\text{SHZ}}$ active, H = $\overline{\text{HOLD}}$ active, R = $\overline{\text{RESET}}$ active

¶ Recommended decoupling capacitor is 0.1 μF .

NOTE 1: CVSS, VSS, and IVSS are on the same plane.



POST OFFICE BOX 1443 • HOUSTON, TEXAS 77251-1443

SMJ320C30 DIGITAL SIGNAL PROCESSOR

SGUS014C – FEBRUARY 1991 – REVISED MARCH 1998

Pin Functions (Continued)

PIN NAME	QTY‡	TYPE†	DESCRIPTION	CONDITIONS WHEN SIGNAL IS Z TYPE§
SUPPLY AND OSCILLATOR SIGNALS (see Note 1) (CONTINUED)				
IVSS	1	I	Ground	
VBBP	1	NC	V _{BB} pump oscillator output	
VSUBS	1	I	Substrate pin. Tie to ground	
X1	1	O	Output from the internal oscillator for the crystal. If a crystal is not used, X1 must be left unconnected.	
X2/CLKIN	1	I	Input to the internal oscillator from the crystal or a clock	
H1	1	O/Z	External H1 clock. H1 has a period equal to twice CLKIN.	S
H3	1	O/Z	External H3 clock. H3 has a period equal to twice CLKIN.	S
RESERVED (see Note 2)				
EMU0–EMU2	3	I	Reserved. Use pullup resistors to 5 V	
EMU3	1	O/Z	Reserved	S
EMU4/ $\overline{\text{SHZ}}$	1	I	Shutdown high impedance. When active, EMU4/ $\overline{\text{SHZ}}$ shuts down the SMJ320C30 and places all pins in the high-impedance state. EMU4/ $\overline{\text{SHZ}}$ is used for board-level testing to ensure that no dual-drive conditions occur. CAUTION: A low on $\overline{\text{SHZ}}$ corrupts SMJ320C30 memory and register contents. Reset the device with $\overline{\text{SHZ}}$ high to restore it to a known operating condition.	
EMU5, EMU6	2	NC	Reserved	
RSV0–RSV4	5	I	Reserved. Tie pins directly to 5 V	
RSV5–RSV10	6	I/O	Reserved. Use pullups on each pin to 5 V	
Locator	1	NC	Reserved	

† I = input, O = output, Z = high-impedance state, NC = No Connect

‡ For GB package

§ S = $\overline{\text{SHZ}}$ active, H = $\overline{\text{HOLD}}$ active, R = $\overline{\text{RESET}}$ active

NOTES: 1. CV_{SS}, V_{SS}, IV_{SS} are on the same plane.

2. The connections specified for the reserved pins must be followed. For best results, 18-k Ω –22-k Ω pullup resistors are recommended. All 5-V supply pins must be connected to a common supply plane, and all ground pins must be connected to a common ground plane.



SMJ320C30 DIGITAL SIGNAL PROCESSOR

SGUS014C - FEBRUARY 1991 - REVISED MARCH 1998

Pin Assignments

PIN			PIN			PIN			PIN			PIN		
NUMBER		NAME	NUMBER		NAME	NUMBER		NAME	NUMBER		NAME	NUMBER		NAME
GB PKG	HFG PKG		GB PKG	HFG PKG		GB PKG	HFG PKG		GB PKG	HFG PKG		GB PKG	HFG PKG	
F15	82	A0	C5	139	D5	P2	195	DX1	L2	185	RSV6	R8	29	XD11
G12	81	A1	D6	138	D6	F14	83	EMU0	K4	186	RSV7	R9	30	XD12
G13	80	A2	A4	137	D7	E15	84	EMU1	M1	187	RSV8	P9	31	XD13
G14	79	A3	B5	136	D8	F13	85	EMU2	L3	188	RSV9	N9	32	XD14
G15	78	A4	C6	135	D9	E14	86	EMU3	M2	189	RSV10	R10	33	XD15
H15	77	A5	A5	134	D10	F12	87	EMU4/SRZ	D12	100	ADV _{DD} [†]	M9	34	XD16
H14	72	A6	B6	133	D11	C1	155	EMU5	H11	64	ADV _{DD} [†]	P10	35	XD17
J15	71	A7	D7	132	D12	M6	11	EMU6	D4	114	DDV _{DD} [†]	R11	36	XD18
J14	70	A8	A6	131	D13	B3	145	H1	E8	147	DDV _{DD} [†]	N10	37	XD19
J13	69	A9	C7	130	D14	A1	146	H3	L8	15	IODV _{DD} [†]	P11	38	XD20
K15	68	A10	B7	129	D15	C2	152	X1	M12	16	IODV _{DD} [†]	R12	39	XD21
J12	67	A11	A7	128	D16	B1	151	X2/CLKIN		49	IODV _{DD} [†]	M10	40	XD22
K14	66	A12	A8	127	D17	P4	9	TCLK0	H5	162	MDV _{DD} [†]	N11	41	XD23
L15	65	A13	B8	122	D18	N5	10	TCLK1		163	MDV _{DD} [†]	P12	42	XD24
K13	63	A14	A9	121	D19	G2	169	XF0	M4	1	PDV _{DD} [†]	R13	43	XD25
L14	62	A15	B9	120	D20	G3	168	XF1	B2	51	CV _{SS} [§]	R14	44	XD26
M15	61	A16	C9	119	D21	D3	154	V _{BBP}	P14	52	CV _{SS} [§]	M11	45	XD27
K12	60	A17	A10	118	D22	E4	153	V _{SUBS}		25	V _{DD} [‡]	N12	46	XD28
L13	59	A18	D9	117	D23	H4	123	V _{DD} [‡]		26	V _{DD} [‡]	P13	47	XD29
M14	58	A19	B10	116	D24	D8	73	V _{DD} [‡]		172	V _{DD} [‡]	R15	48	XD30
N15	57	A20	A11	115	D25	M8	74	V _{DD} [‡]		173	V _{DD} [‡]	P15	53	XD31
M13	56	A21	C10	113	D26	H12	124	V _{DD} [‡]	C8	28	V _{SS} [§]		2	DV _{DD}
L12	55	A22	B11	112	D27	N8	27	V _{SS} [§]	H3	75	V _{SS} [§]		101	DV _{DD}
N14	54	A23	A12	111	D28	A13	107	XA0	H13	76	V _{SS} [§]	C3	50	DV _{SS} [¶]
E5		LOCATOR/NC	D10	110	D29	A14	106	XA1		125	V _{SS} [§]	C13	98	DV _{SS} [¶]
G1	170	TACK	C11	109	D30	D11	105	XA2		126	V _{SS} [§]	N3	148	DV _{SS} [¶]
H2	171	INT0	B12	108	D31	C12	104	XA3		149	V _{SS} [§]	N13	196	DV _{SS} [¶]
H1	176	INT1	F3	161	HOLD	B13	103	XA4		150	V _{SS} [§]	B14	96	IV _{SS} [¶]
J1	177	INT2	E2	160	HOLDA	A15	102	XA5		174	V _{SS} [§]		97	IV _{SS} [¶]
J2	178	INT3	D2	156	XRDY	B15	95	XA6		175	V _{SS} [§]			
D15	88	MC/MP	D1	159	XR/W	C14	94	XA7		99	V _{SUBS}			
E3	157	MSTRB	P3	4	FSR0	E12	93	XA8	R4	12	XD0			
E1	164	RDY	R2	7	FSX0	D13	92	XA9	P5	13	XD1			
F1	167	RESET	N4	5	CLKR0	C15	91	XA10	N6	14	XD2			
G4	166	R/W	M5	6	CLKX0	D14	90	XA11	R5	17	XD3			
F2	165	STRB	R1	3	DR0	E13	89	XA12	P6	18	XD4			
F4	158	IOSTRB	R3	8	DX0	J3	179	RSV0	M7	19	XD5			
C4	144	D0	M3	191	FSR1	J4	180	RSV1	R6	20	XD6			
D5	143	D1	P1	194	FSX1	K1	181	RSV2	N7	21	XD7			
A2	142	D2	L4	192	CLKR1	K2	182	RSV3	P7	22	XD8			
A3	141	D3	N2	193	CLKX1	L1	183	RSV4	R7	23	XD9			
B4	140	D4	N1	190	DR1	K3	184	RSV5	P8	24	XD10			

† ADV_{DD}, DDV_{DD}, IODV_{DD}, MDV_{DD}, and PDV_{DD} are on a common plane internal to the device.

‡ V_{DD} is on a common plane internal to the device.

§ V_{SS}, CV_{SS}, and IV_{SS} are on a common plane internal to the device.

¶ DV_{SS} is on a common plane internal to the device.



SMJ320C30 DIGITAL SIGNAL PROCESSOR

SGUS014C – FEBRUARY 1991 – REVISED MARCH 1998

absolute maximum ratings over operating free-air temperature range (unless otherwise noted)†

Supply voltage range, V_{CC} (see Note 3)	-0.3 V to 7 V
Input voltage range, V_I	-0.3 V to 7 V
Output voltage range, V_O	-0.3 V to 7 V
Continuous power dissipation (see Note 4)	3.15 W
Operating free-air temperature range, T_A	-55 C to 125°C
Storage temperature range, T_{stg}	-65 C to 150°C

† Stresses beyond those listed under "absolute maximum ratings" may cause permanent damage to the device. These are stress ratings only, and functional operation of the device at these or any other conditions beyond those indicated under "recommended operating conditions" is not implied. Exposure to absolute-maximum-rated conditions for extended periods may affect device reliability.

NOTES: 3. All voltage values are with respect to V_{SS} .

4. Actual operating power is less. This value was obtained under specially produced worst-case test conditions, which are not sustained during normal device operation. These conditions consist of continuous parallel writes of a checkerboard pattern to both primary and extension buses at the maximum rate possible. See normal (I_{CC}) current specification in the electrical characteristics table and also read *Calculation of TMS320C30 Power Dissipation Application Report* (literature number SPRA020).

recommended operating conditions (see Note 5)

		MIN	NOM‡	MAX	UNIT	
V_{DD}	Supply voltage (AV_{DD} , etc.)	'320C30-50	4.75	5	5.25	V
		'320C30-40	4.75	5	5.25	V
		'320C30-33	4.5	5	5.5	V
V_{SS}	Supply voltage (CV_{SS} , etc.)		0		V	
V_{IH}	High-level input voltage	2.1		$V_{DD} + 0.3^*$	V	
V_{TH}	High-level input voltage for CLKIN	3		$V_{DD} + 0.3^*$	V	
V_{IL}	Low-level input voltage	-0.3*		0.8	V	
I_{OH}	High-level output current			-300	μ A	
I_{OL}	Low-level output current			2	mA	
T_A	Operating free-air temperature	-55		125	°C	

‡ All nominal values are at $V_{DD} = 5$ V, $T_A = 25^\circ$ C.

* This parameter is not production tested.

NOTE 5: All input and output voltage levels are TTL compatible.



SMJ320C30 DIGITAL SIGNAL PROCESSOR

SGUS014C – FEBRUARY 1991 – REVISED MARCH 1998

electrical characteristics over recommended ranges of supply voltage (unless otherwise noted) (see Note 5)

PARAMETER		TEST CONDITIONS†	MIN	TYP‡	MAX	UNIT
V _{OH}	High-level output voltage	V _{DD} = MIN, I _{OH} = MAX	2.4	3		V
V _{OL}	Low-level output voltage	For XA12–XA0			0.6*	V
		All others	V _{DD} = MIN, I _{OL} = MAX		0.3	0.6
I _Z	High-impedance current	V _{DD} = MAX			± 20	μA
I _I	Input current	V _I = V _{SS} to V _{DD}			± 10	μA
I _{IP}	Input current	Inputs with internal pullups (see Note 6)	– 400		20	μA
I _{IC}	Input current (X2/CLKIN)	V _I = V _{SS} to V _{DD}			± 50	μA
I _{CC}	Supply current	V _{DD} = MAX, T _A = 25°C, t _c (Cl) = MIN, See Note 7		200	600	mA
I _{DD}	Supply current, standby; IDLE2, clock shut off	V _{DD} = 5 V, T _A = 25°C		50		mA
C _i	Input capacitance				15*	pF
C _o	Output capacitance				20*	pF
C _x	X2/CLKIN capacitance				25*	pF

† For conditions shown as MIN/MAX, use the appropriate value specified in recommended operating conditions.

‡ All typical values are at V_{DD} = 5 V, T_A = 25°C.

* This parameter is not production tested.

NOTES: 5. All input and output voltage levels are TTL compatible.

6. Pins with internal pullup devices: INT0–INT3, MC/MP, RSV0–RSV10. Although RSV0–RSV10 have internal pullup devices, external pullups should be used on each pin as identified in the pin function tables.

7. Actual operating current is less than this maximum value. This value was obtained under specially produced worst-case test conditions, which are not sustained during normal device operation. These conditions consist of continuous parallel writes of checkerboard pattern to both primary and expansion buses at the maximum rate possible. See *Calculation of TMS320C30 Power Dissipation Application Report* (literature number SPRA020).

PARAMETER MEASUREMENT INFORMATION

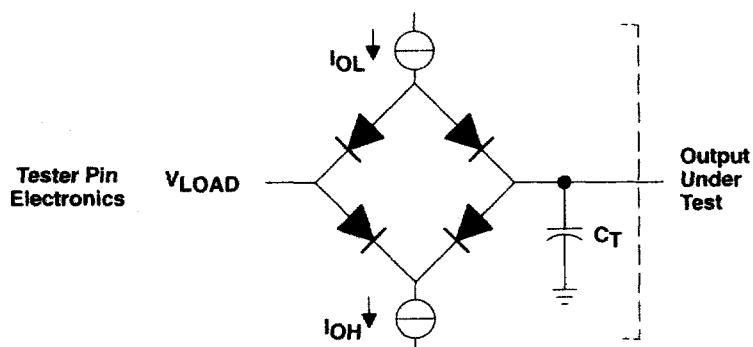

Where: I_{OL} = 2 mA (all outputs)
 I_{OH} = 300 μA (all outputs)
 V_{LOAD} = Selected to emulate 50 Ω termination (typical value = 1.54 V).
 C_T = 80-pF typical load-circuit capacitance

Figure 4. Test Load Circuit

PARAMETER MEASUREMENT INFORMATION

signal transition levels

TTL-level outputs are driven to a minimum logic-high level of 2.4 V and to a maximum logic-low level of 0.6 V. Output transition times are specified as follows:

- For a high-to-low transition on a TTL-compatible output signal, the level at which the output is said to be no longer high is 2 V and the level at which the output is said to be low is 1 V.
- For a low-to-high transition, the level at which the output is said to be no longer low is 1 V and the level at which the output is said to be high is 2 V.

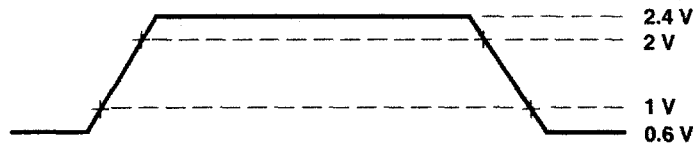

Figure 5. TTL-Level Outputs

Transition times for TTL-compatible inputs are specified as follows:

- For a high-to-low transition on an input signal, the level at which the input is said to be no longer high is 2.1 V and the level at which the input is said to be low is 0.8 V.
- For a low-to-high transition on an input signal, the level at which the input is said to be no longer low is 0.8 V and the level at which the input is said to be high is 2.1 V.

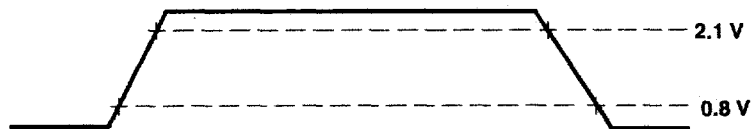

Figure 6. TTL-Level Inputs

SMJ320C30 DIGITAL SIGNAL PROCESSOR

SGUS014C – FEBRUARY 1991 – REVISED MARCH 1998

PARAMETER MEASUREMENT INFORMATION

timing parameter symbology

Timing parameter symbols used herein were created in accordance with JEDEC Standard 100-A. To shorten the symbols, some of the terminal names and other related terminology have been abbreviated as follows, unless otherwise noted:

A	A23–A0	IACK	$\overline{\text{IACK}}$
ASYNCH	Asynchronous reset signals include XF0, XF1, CLKX0, DX0, FSX0, CLKR0, DR0, FSR0, CLKX1, DX1, FSX1, CLKR1, DR1, FSR1, TCLK0, and TCLK1	INT	$\overline{\text{INT3}}\text{--}\overline{\text{INT0}}$
CH	CLKX includes CLKX0 and CLKX1	IOS	$\overline{\text{IOSTRB}}$
CI	CLKIN	(M)S	$\overline{\text{(M)STRB}}$ includes $\overline{\text{MSTRB}}$ and $\overline{\text{STRB}}$
CONTROL	Control signals include $\overline{\text{STRB}}$, $\overline{\text{MSTRB}}$, and $\overline{\text{IOSTRB}}$	RDY	$\overline{\text{RDY}}$
D	D31–D0	RESET	$\overline{\text{RESET}}$
DR	Includes DR0, DR1	RW	$\overline{\text{R/W}}$
DX	Includes DX0, DX1	S	$\overline{\text{STRB}}$
FS	FSX/R includes FSX0, FSX1, FSR0, and FSR1	SCK	CLKX/R includes CLKX0, CLKX1, CLKR0, and CLKR1
FSR	Includes FSR0, FSR1	TCLK	TCLK0, TCLK1
FSX	Includes FSX0, FSX1	(X)A	Includes A23–A0 and XA12–XA0
GPIO	General-purpose input/output; peripheral pins include CLKX0/1, CLKR0/1, DX0/1, DR0/1, FSX0/1, FSR0/1, and TCLK0/1	(X)D	Includes D31–D0 and XD31–XD0
H	Includes H1, H3	XF	XFx includes XF0 and XF1
H1	H1	XF0	XF0
H3	H3	XF1	XF1
HOLD	$\overline{\text{HOLD}}$	(X)RDY	Includes $\overline{\text{RDY}}$ and $\overline{\text{XRDY}}$
HOLDA	$\overline{\text{HOLDA}}$	(X)RW	$\overline{\text{(X)R/W}}$ includes $\overline{\text{R/W}}$ and $\overline{\text{XR/W}}$



POST OFFICE BOX 1443 • HOUSTON, TEXAS 77251-1443

X2/CLKIN, H1, and H3 timing

The following table defines the timing parameters for the X2/CLKIN, H1, and H3 interface signals. See the RESET timing in Figure 20 for CLKIN to H1 and H3 delay specification.

timing parameters for X2/CLKIN, H1, H3 (see Note 5, Figure 7, Figure 8, and Figure 9)

NO.†		'320C30-33		'320C30-40		'320C30-50		UNIT
		MIN	MAX	MIN	MAX	MIN	MAX	
1	$t_f(CI)$ Fall time, CLKIN		5*		5*		5*	ns
2	$t_w(CIL)$ Pulse duration, CLKIN low, $t_c(CI) = \text{MIN}$ (see Note 8)	10.5		9		7		ns
3	$t_w(CIH)$ Pulse duration, CLKIN high, $t_c(CI) = \text{MIN}$ (see Note 8)	10.5		9		7		ns
4	$t_r(CI)$ Rise time, CLKIN		5*		5*		5*	ns
5	$t_c(CI)$ Cycle time, CLKIN	30	303	25	303	20	303	ns
6	$t_f(H)$ Fall time, H1/H3		3		3		3	ns
7	$t_w(HL)$ Pulse duration, H1/H3 low (see Note 9)	P – 6		P – 5		P – 5		ns
8	$t_w(HH)$ Pulse duration, H1/H3 high (see Note 9)	P – 7		P – 6		P – 6		ns
9	$t_r(H)$ Rise time, H1/H3		4		3		3	ns
9.1	$t_d(HL-HH)$ Delay time, from H1 low to H3 high or from H3 low to H1 high	0	5	0	4	0	4	ns
10	$t_c(H)$ Cycle time, H1/H3	60	606	50	606	40	606	ns

† Numbers in this column match those used in Figure 7, Figure 8, and Figure 9.

* This parameter is not production tested.

NOTES: 5. All input and output voltage levels are TTL compatible.

8. Rise and fall times, assuming a 35 – 65% duty cycle, are incorporated within this specification (see Figure 6).

9. $P = t_c(CI)$

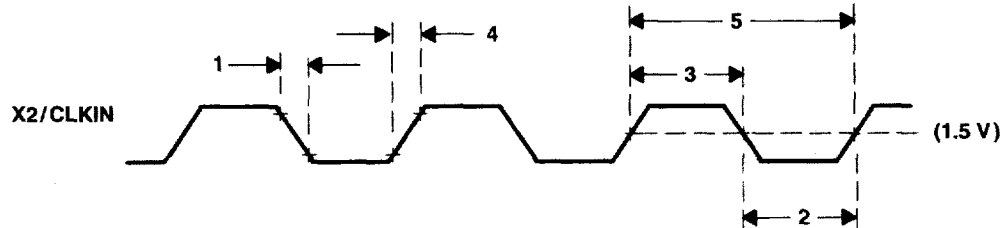

Figure 7. X2/CLKIN Timing

SMJ320C30
DIGITAL SIGNAL PROCESSOR

SGUS014C - FEBRUARY 1991 - REVISED MARCH 1998

timing parameters for X2/CLKIN, H1, H3 (see Note 5, Figure 7, Figure 8, and Figure 9) (continued)

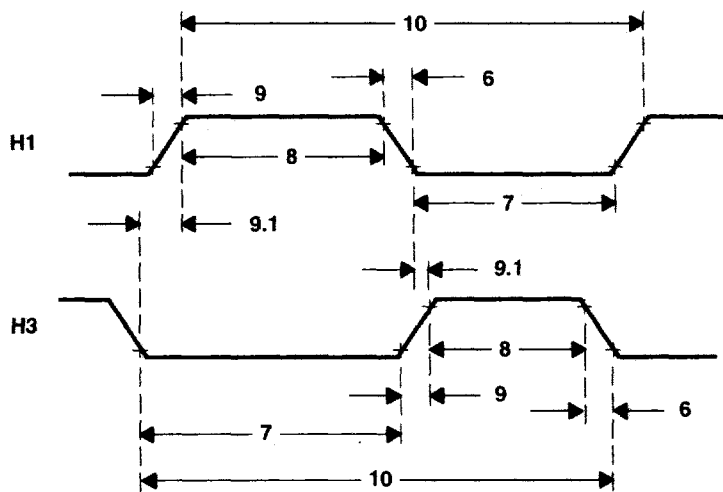

Figure 8. H1/H3 Timings

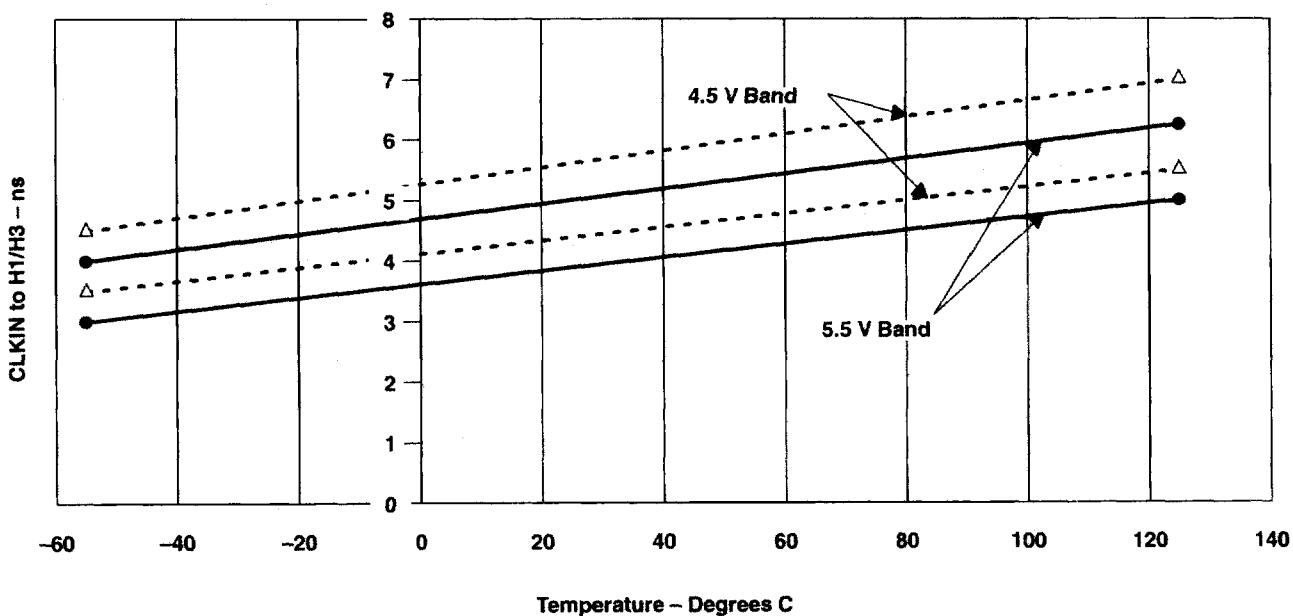

Figure 9. CLKIN to H1/H3 as a Function of Temperature (Typical)

memory read/write timing

The following table defines memory read/write timing parameters for $\overline{(M)STRB}$.

timing parameters for a memory [$\overline{(M)STRB} = 0$] read/write (see Figure 10 and Figure 11)

NO.T			'320C30-33		'320C30-40		'320C30-50		UNIT
			MIN	MAX	MIN	MAX	MIN	MAX	
11	$t_{d[H1L-(M)SL]}$	Delay time, H1 low to $\overline{(M)STRB}$ low	0*	10	0*	10	0*	4	ns
12	$t_{d[H1L-(M)SH]}$	Delay time, H1 low to $\overline{(M)STRB}$ high	0*	10	0*	6	0*	4	ns
13.1	$t_{d[H1H-RWL]}$	Delay time, H1 high to R/ \overline{W} low	0*	10	0*	9	0*	7	ns
13.2	$t_{d[H1H-(X)RWL]}$	Delay time, H1 high to (X)R/ \overline{W} low	0*	15	0*	13	0*	11	ns
14.1	$t_{d[H1L-A]}$	Delay time, H1 low to A valid	0*	14	0*	14	0*	9	ns
14.2	$t_{d[H1L-(X)A]}$	Delay time, H1 low to (X)A valid	0*	10	0*	9	0*	8	ns
15.1	$t_{su[D-H1L]R}$	Setup time, D valid before H1 low (read)	16		14		10		ns
15.2	$t_{su[(X)DR-H1L]R}$	Setup time, (X)D before H1 low (read)	18		16		14		ns
16	$t_h[H1L-(X)D]R$	Hold time, (X)D after H1 low (read)	0*		0*		0*		ns
17.1	$t_{su[RDY-H1H]}$	Setup time, \overline{RDY} before H1 high	8		8		6		ns
17.2	$t_{su[(X)RDY-H1H]}$	Setup time, $\overline{(X)RDY}$ before H1 high	9		9		8		ns
18	$t_h[H1H-(X)RDY]$	Hold time, $\overline{(X)RDY}$ after H1 high	0		0		0		ns
19	$t_{d[H1H-(X)RWH]W}$	Delay time, H1 high to (X)R/ \overline{W} high (write)		10		9		7	ns
20	$t_v[H1L(X)D]W$	Valid time, (X)D after H1 low (write)		20		17		14	ns
21	$t_h[H1H-(X)D]W$	Hold time, (X)D after H1 high (write)	0*		0*		0*		ns
22.1	$t_{d[H1H-A]}$	Delay time, H1 high to A valid on back-to-back write cycles (write)		18		15		12	ns
22.2	$t_{d[H1H-(X)A]}$	Delay time, H1 high to (X)A valid on back-to-back write cycles (write)		25		21		18	ns
26	$t_{d[A-(X)RDY]}$	Delay time, $\overline{(X)RDY}$ from A valid	8*		7*		6*		ns

† Numbers in this column match those used in Figure 10 and Figure 11.

* This parameter is not production tested.

**SMJ320C30
DIGITAL SIGNAL PROCESSOR**

SGUS014C – FEBRUARY 1991 – REVISED MARCH 1998

memory read/write timing (continued)

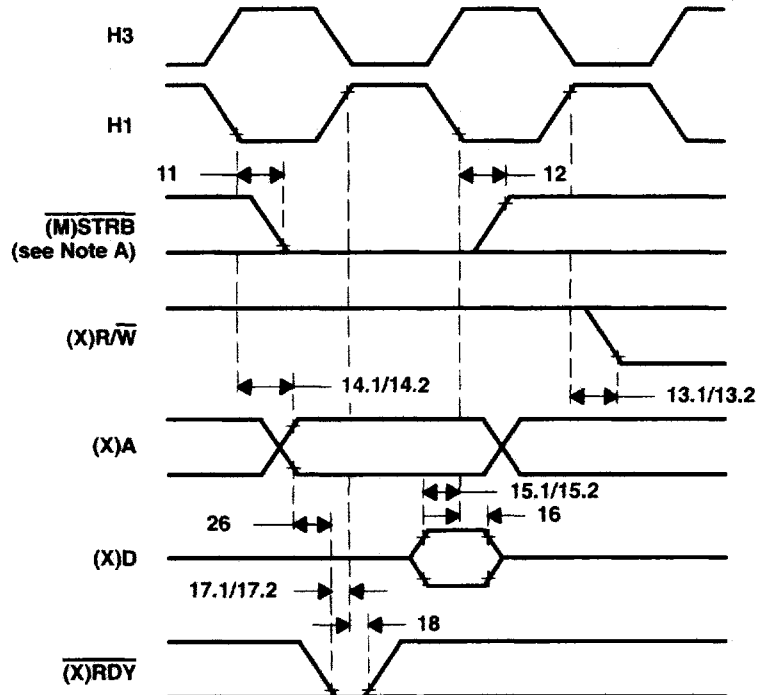

NOTE A: (M)STRB remains low during back-to-back read operations.

Figure 10. Timing for Memory [(M)STRB = 0] Read



POST OFFICE BOX 1443 • HOUSTON, TEXAS 77251-1443

memory read/write timing (continued)

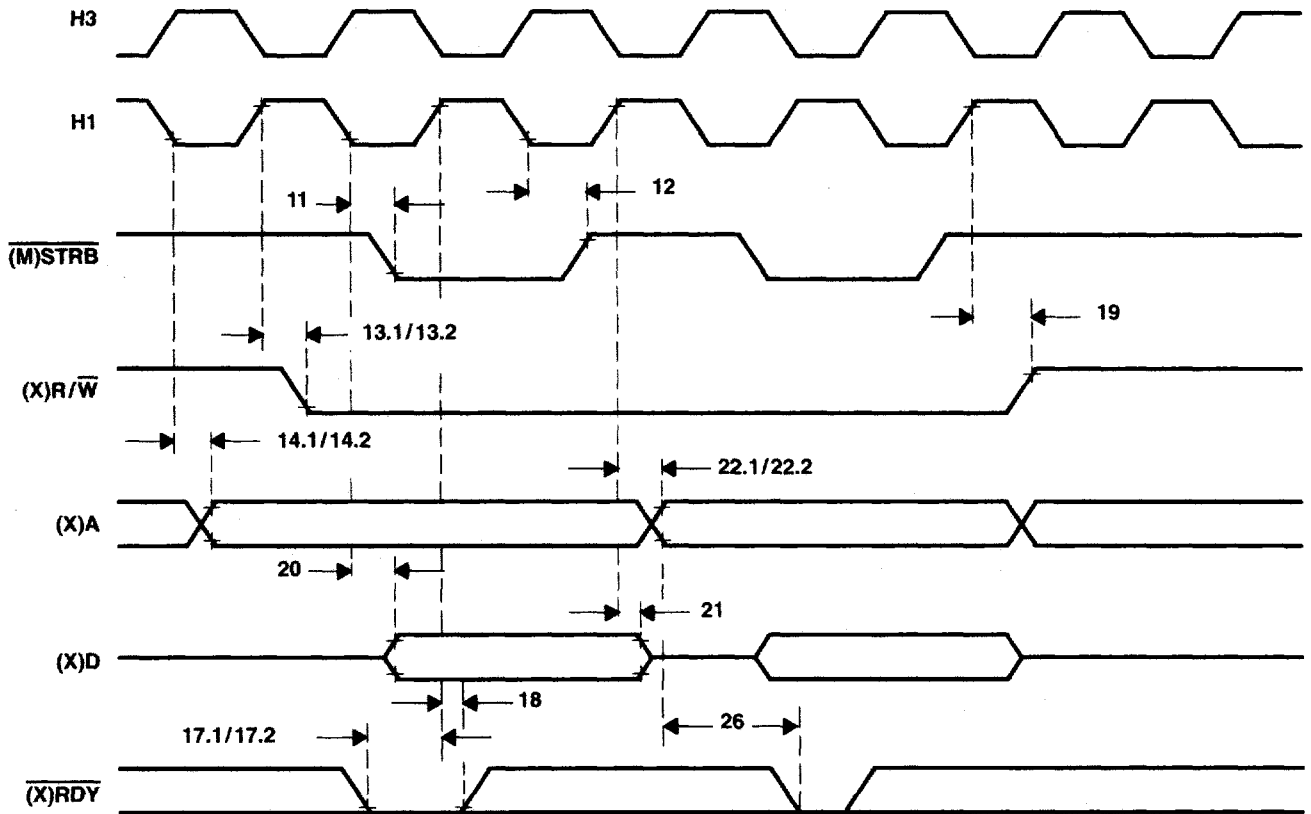

Figure 11. Timing for Memory [(M)STRB = 0] Write

SMJ320C30 DIGITAL SIGNAL PROCESSOR

SGUS014C – FEBRUARY 1991 – REVISED MARCH 1998

memory read/write timing (continued)

The following table defines memory read timing parameters for $\overline{\text{IOSTRB}}$.

timing parameters for a memory ($\overline{\text{IOSTRB}} = 0$) read (see Figure 12)

NO.T		'320C30-33		'320C30-40		'320C30-50		UNIT
		MIN	MAX	MIN	MAX	MIN	MAX	
27	$t_{d(H1H\text{-}IO\text{SL})}$ Delay time, H1 high to $\overline{\text{IOSTRB}}$ low	0*	10	0*	9	0*	8	ns
28	$t_{d(H1H\text{-}IO\text{SH})}$ Delay time, H1 high to $\overline{\text{IOSTRB}}$ high	0*	10	0*	9	0*	8	ns
29	$t_{d(H1L\text{-}(X)R\text{W}H)}$ Delay time, H1 low to (X)R/ $\overline{\text{W}}$ high	0*	10	0*	9	0*	8	ns
30	$t_{d(H1L\text{-}(X)A)}$ Delay time, H1 low to (X)A valid	0*	10	0*	9	0*	8	ns
31	$t_{su(X)D\text{-}H1H}R$ Setup time, (X)D before H1 high	15		13		11		ns
32	$t_h[H1H\text{-}(X)D]R$ Hold time, (X)D after H1 high	0*		0*		0*		ns
33	$t_{su(X)RDY\text{-}H1H}$ Setup time, (X)RDY before H1 high	9		9		8		ns
34	$t_h[H1H\text{-}(X)RDY]$ Hold time, (X)RDY after H1 high	0		0		0		ns

† Numbers in this column match those used in Figure 12.

* This parameter is not production tested.

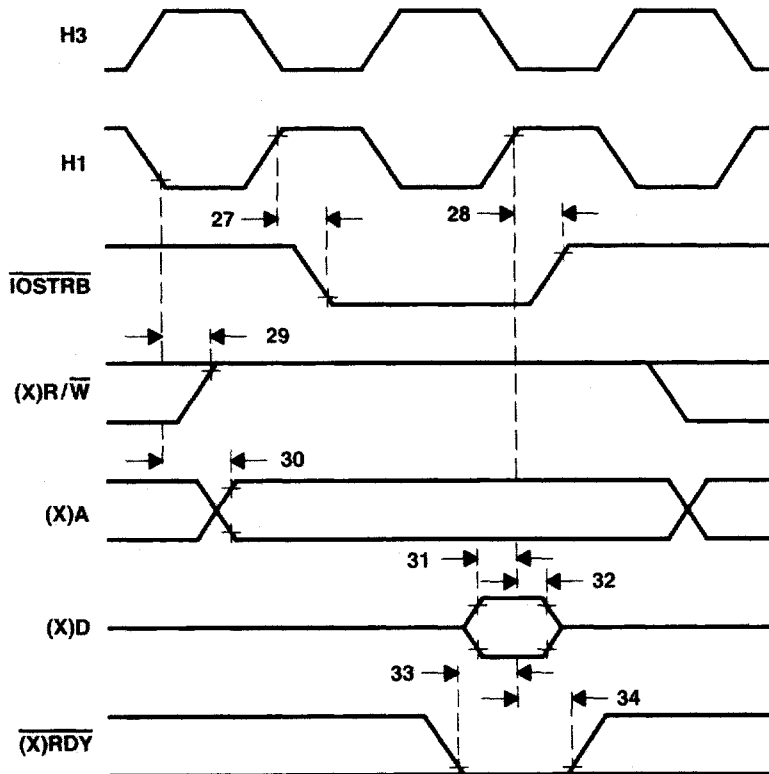

Figure 12. Timing for Memory ($\overline{\text{IOSTRB}} = 0$) Read

memory read/write timing (continued)

The following table defines memory write timing parameters for $\overline{\text{IOSTRB}}$.

timing parameters for a memory ($\overline{\text{IOSTRB}} = 0$) write (see Figure 13)

NO.T		'320C30-33		'320C30-40		'320C30-50		UNIT
		MIN	MAX	MIN	MAX	MIN	MAX	
27	$t_{d[H1H-IOSL]}$ Delay time, H1 high to $\overline{\text{IOSTRB}}$ low	0*	10	0*	9	0*	8	ns
28	$t_{d[H1H-IOSH]}$ Delay time, H1 high to $\overline{\text{IOSTRB}}$ high	0*	10	0*	9	0*	8	ns
29	$t_{d[H1L-(X)R\overline{W}]}$ Delay time, H1 low to (X)R/ \overline{W} high	0*	10	0*	9	0*	8	ns
30	$t_{d[H1L-(X)A]}$ Delay time, H1 low to (X)A valid	0*	10	0*	9	0*	8	ns
33	$t_{su[(X)RDY-H1H]}$ Setup time, $\overline{(X)RDY}$ before H1 high	9		9		8		ns
34	$t_h[H1H-(X)RDY]$ Hold time, $\overline{(X)RDY}$ after H1 high	0		0		0		ns
35	$t_{d[H1L-XR\overline{W}]}$ Delay time, H1 low to XR/ \overline{W} low	0*	15	0*	13	0*	11	ns
36	$t_v[H1H(X)D]\overline{W}$ Valid time, (X)D after H1 high		30		25		20	ns
37	$t_h[H1L-(X)D]\overline{W}$ Hold time, (X)D after H1 low	0		0		0		ns

† Numbers in this column match those used in Figure 13.

* This parameter is not production tested.

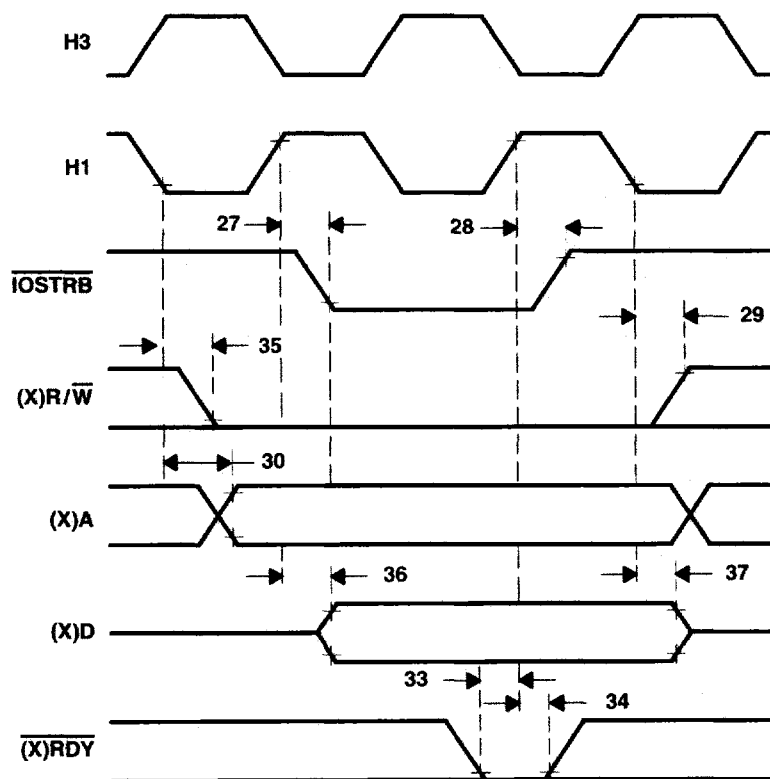

Figure 13. Timing for Memory ($\overline{\text{IOSTRB}} = 0$) Write

SMJ320C30 DIGITAL SIGNAL PROCESSOR

SGUS014C – FEBRUARY 1991 – REVISED MARCH 1998

XF0 and XF1 timing when executing LDFI or LDII

The following table defines the timing parameters for XF0 and XF1 during execution of LDFI or LDII.

timing parameters for XF0 and XF1 when executing LDFI or LDII (see Figure 14)

NO.T		'320C30-33		'320C30-40		'320C30-50		UNIT
		MIN	MAX	MIN	MAX	MIN	MAX	
38	$t_d(H3H-XF0L)$ Delay time, H3 high to XF0 low		15		13		12	ns
39	$t_{su}(XF1-H1L)$ Setup time, XF1 valid before H1 low	12		9		9		ns
40	$t_h(H1L-XF1)$ Hold time, XF1 after H1 low	0		0		0		ns

† Numbers in this column match those used in Figure 14.

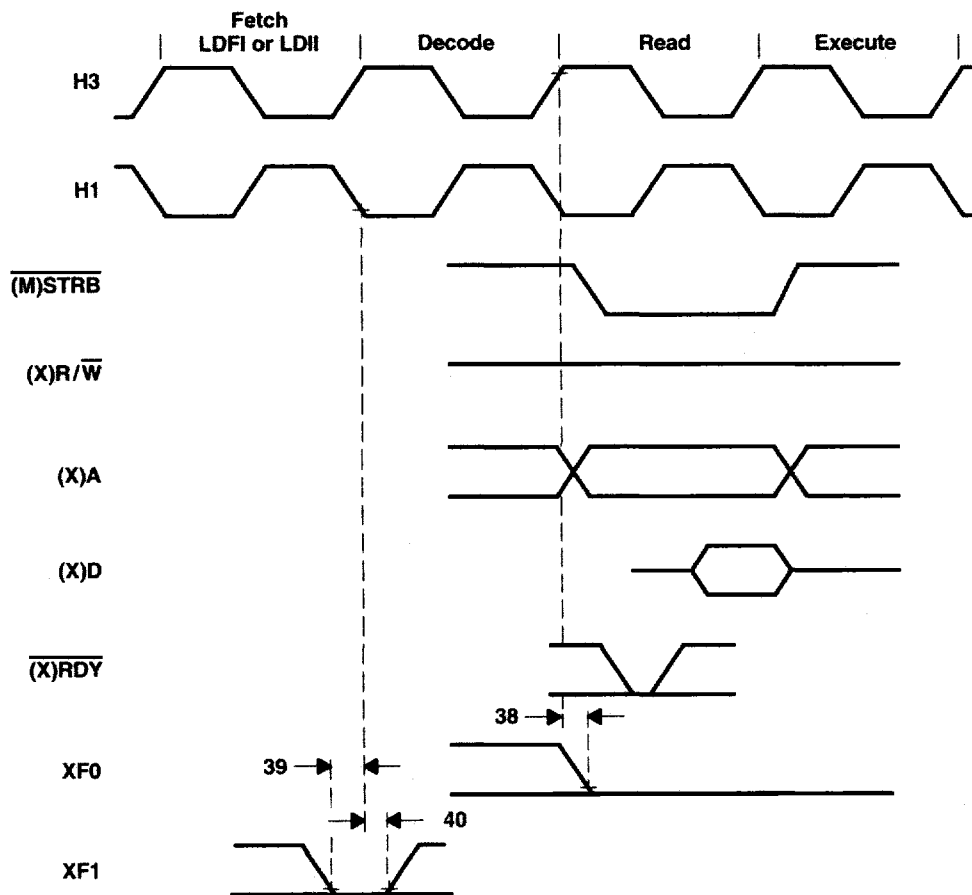

Figure 14. Timing for XF0 and XF1 When Executing LDFI or LDII



XF0 timing when executing STFI and STII

The following table defines the timing parameters for the XF0 pin during execution of STFI or STII.

timing parameters for XF0 when executing STFI or STII (see Figure 15)

NO.T		'320C30-33		'320C30-40		'320C30-50		UNIT
		MIN	MAX	MIN	MAX	MIN	MAX	
41	$t_d(H3H-XF0H)$ Delay time, H3 high to XF0 high		18		13		12	ns

† The number in this column matches that used in Figure 15.

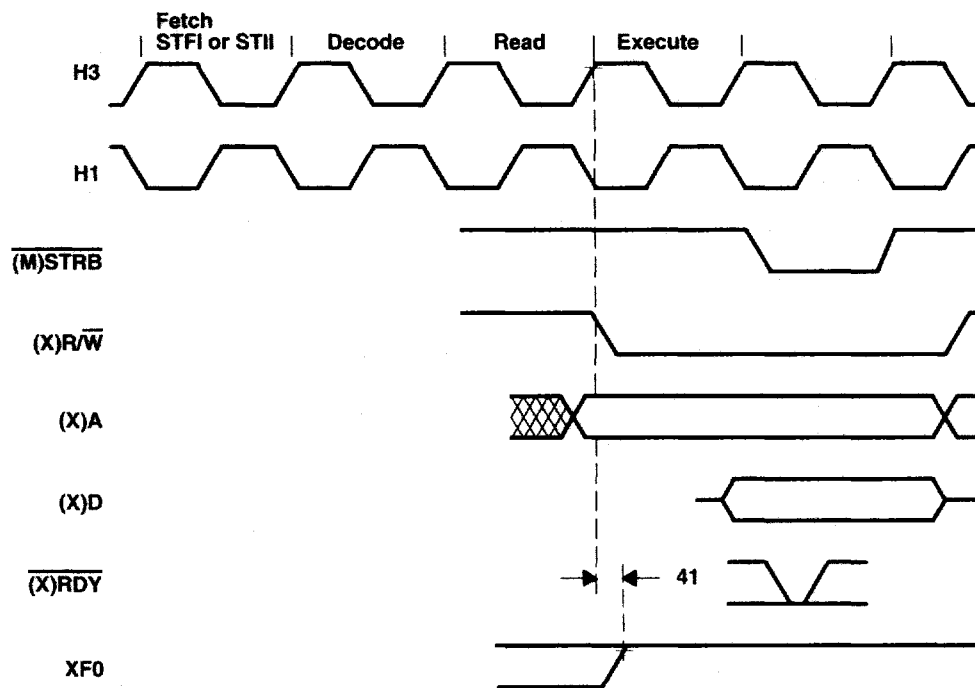

Figure 15. Timing for XF0 When Executing an STFI or STII

SMJ320C30 DIGITAL SIGNAL PROCESSOR

SGUS014C – FEBRUARY 1991 – REVISED MARCH 1998

XF0 and XF1 timing when executing SIGI

The following table defines the timing parameters for the XF0 and XF1 pins during execution of SIGI.

timing parameters for XF0 and XF1 when executing SIGI (see Figure 16)

NO.T		'320C30-33		'320C30-40		'320C30-50		UNIT
		MIN	MAX	MIN	MAX	MIN	MAX	
41.1	$t_d(H3H-XF0L)$ Delay time, H3 high to XF0 low	15		13		12		ns
42	$t_d(H3H-XF0H)$ Delay time, H3 high to XF0 high	18		13		12		ns
43	$t_{su}(XF1-H1L)$ Setup time, XF1 valid before H1 low	12		9		9		ns
44	$t_h(H1L-XF1)$ Hold time, XF1 after H1 low	0		0		0		ns

† Numbers in this column match those used in Figure 16.

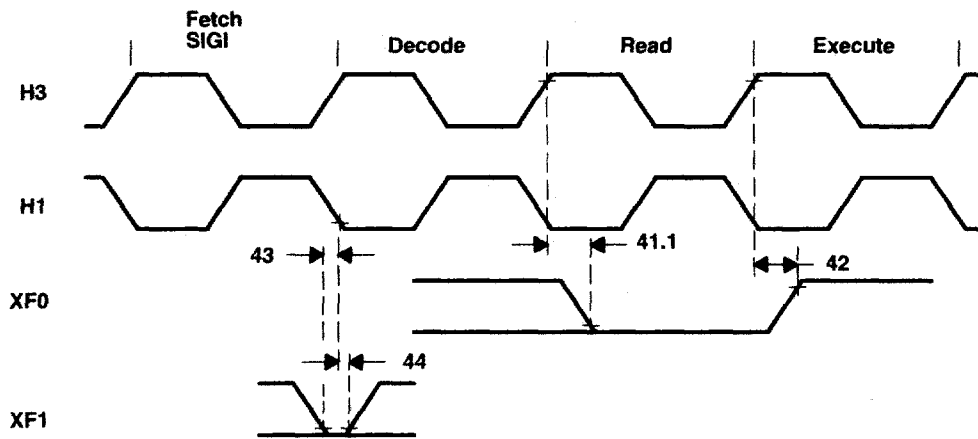

Figure 16. Timing for XF0 and XF1 When Executing SIGI

loading when XFx is configured as an output

The following table defines the timing parameter for loading the XF register when the XFx pin is configured as an output.

timing parameters for loading the XFx register when configured as an output pin (see Figure 17)

NO.†		'320C30-33		'320C30-40		'320C30-50		UNIT
		MIN	MAX	MIN	MAX	MIN	MAX	
45	$t_v(H3H-XF)$ Valid time, H3 high to XF valid		15		13		12	ns

† The number in this column matches that used in Figure 17.

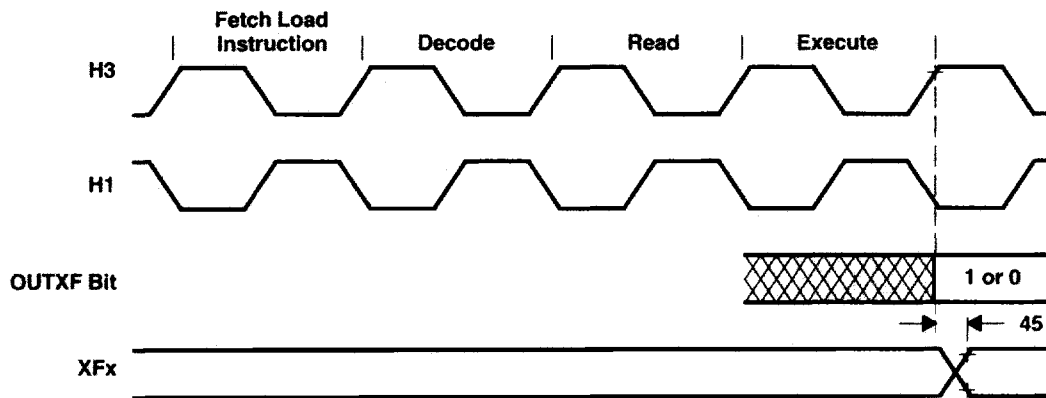

NOTE A: OUTXFx represents either bit 2 or 6 of the IOF register.

Figure 17. Timing for Loading XFx Register When Configured as an Output Pin

SMJ320C30 DIGITAL SIGNAL PROCESSOR

SGUS014C – FEBRUARY 1991 – REVISED MARCH 1998

changing XF_x from an output to an input

The following table defines the timing parameters for changing the XF_x pin from an output pin to an input pin.

timing parameters of XF_x changing from output to input mode (see Figure 18)

NO.T		'320C30-33		'320C30-40		'320C30-50		UNIT
		MIN	MAX	MIN	MAX	MIN	MAX	
46	$t_d(H3H-XF_x)$ Delay time, XF _x after H3 high		15*		13*		12*	ns
47	$t_{su}(XF_x-H1L)$ Setup time, XF _x before H1 low	12		9		9		ns
48	$t_h(H1L-XF_x)$ Hold time, XF _x after H1 low	0		0		0		ns

† Numbers in this column match those used in Figure 18.

* This parameter is not production tested.

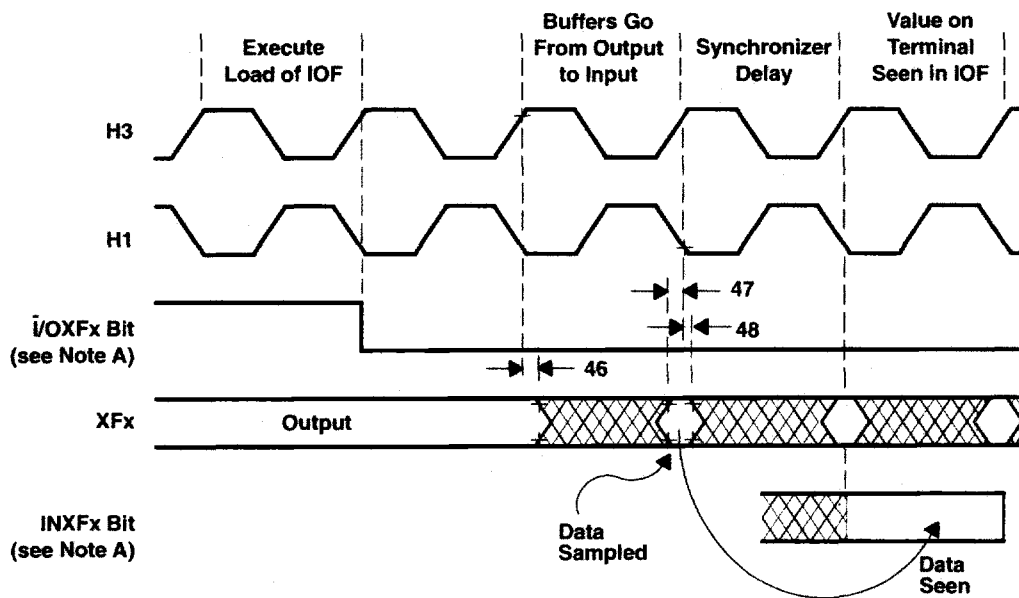

NOTE A: \bar{i}/OXF_x represents either bit 1 or bit 5 of the IOF register, and $INXF_x$ represents either bit 3 or bit 7 of the IOF register depending on whether XF₀ or XF₁, respectively, is being affected.

Figure 18. Timing for Change of XF_x From Output to Input Mode

changing XFx from an input to an output

The following table defines the timing parameter for changing the XFx pin from an input pin to an output pin.

timing parameters of XFx changing from input to output mode (see Figure 19)

NO.†		'320C30-33		'320C30-40		'320C30-50		UNIT
		MIN	MAX	MIN	MAX	MIN	MAX	
49	$t_{d(H3H-XFIO)}$ Delay time, H3 high to XF switching from input to output		20		17		17	ns

† The number in this column matches that used in Figure 19.

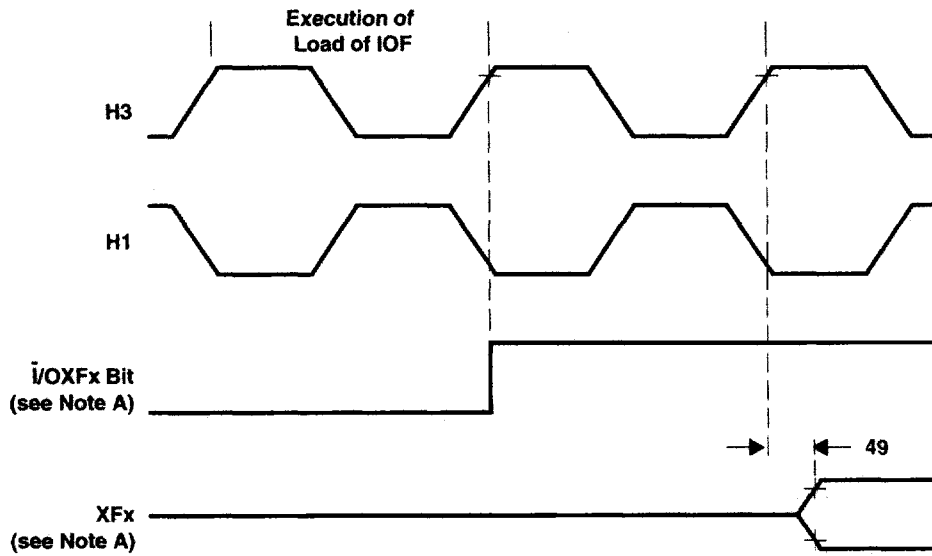

NOTE A: \bar{i}/OXF_x represents either bit 1 or bit 5 of the IOF register, and $INXF_x$ represents either bit 3 or bit 7 of the IOF register depending on whether XF0 or XF1, respectively, is being affected.

Figure 19. Timing for Change of XFx From Input to Output Mode

SMJ320C30 DIGITAL SIGNAL PROCESSOR

SGUS014C – FEBRUARY 1991 – REVISED MARCH 1998

reset timing

$\overline{\text{RESET}}$ is an asynchronous input that can be asserted at any time during a clock cycle. If the specified timings are met, the exact sequence shown in Figure 20 occurs; otherwise, an additional delay of one clock cycle can occur. $\overline{\text{R/W}}$ and $\overline{\text{XR/W}}$ are in the high-impedance state during reset and can be provided with a resistive pullup, nominally 18 k Ω to 22 k Ω , to prevent spurious writes from occurring. The asynchronous reset signals include $\overline{\text{XF0/1}}$, $\overline{\text{CLKX0/1}}$, $\overline{\text{DX0/1}}$, $\overline{\text{FSX0/1}}$, $\overline{\text{CLKR0/1}}$, $\overline{\text{DR0/1}}$, $\overline{\text{FSR0/1}}$, and $\overline{\text{TCLK0/1}}$. $\overline{\text{HOLD}}$ is an asynchronous input and can be asserted during reset.

Resetting the device initializes the primary- and expansion-bus control registers to seven software wait states and, therefore, results in slow external accesses until these registers are initialized.

timing parameters for $\overline{\text{RESET}}$ [$P = t_c(C1)$] (see Figure 9 and Figure 20)

NO.			'320C30-33		'320C30-40		'320C30-50		UNIT
			MIN	MAX	MIN	MAX	MIN	MAX	
50	$t_{su}(\overline{\text{RESET}})$	Setup time, $\overline{\text{RESET}}$ before CLKIN low	10	P*	10	P*	10	P*	ns
51	$t_d(\text{CLKINH-H1H})$	Delay time, CLKIN high to H1 high [†]	2	14	2	14	2	10	ns
52	$t_d(\text{CLKINH-H1L})$	Delay time, CLKIN high to H1 low [†]	2	14	2	14	2	10	ns
53	$t_{su}(\overline{\text{RESETH-H1L}})$	Setup time, $\overline{\text{RESETH}}$ high before H1 low after ten H1 clock cycles	10		9		7		ns
54	$t_d(\text{CLKINH-H3L})$	Delay time, CLKIN high to H3 low [†]	2	14	2	14	2	10	ns
55	$t_d(\text{CLKINH-H3H})$	Delay time, CLKIN high to H3 high [†]	2	14	2	14	2	10	ns
56	$t_{dis}(\text{H1H-XD})$	Disable time, H1 high to (X)D high-impedance state		18*		15*		12*	ns
57	$t_{dis}(\text{H3H-XA})$	Disable time, H3 high to (X)A high-impedance state		10*		9*		8*	ns
58	$t_d(\text{H3H-CONTROLH})$	Delay time, H3 high to control signals high		10*		9*		8*	ns
59	$t_d(\text{H1H-IACKH})$	Delay time, H1 high to IACK high		10*		9*		8*	ns
60	$t_{dis}(\overline{\text{RESETH-ASYNCH}})$	Disable time, $\overline{\text{RESETH}}$ low to asynchronous reset signals in the high-impedance state		25*		21*		17*	ns

[†] See Figure 9 for temperature dependence for the 40-MHz SMJ320C30.

* This parameter is not production tested.



reset timing (continued)

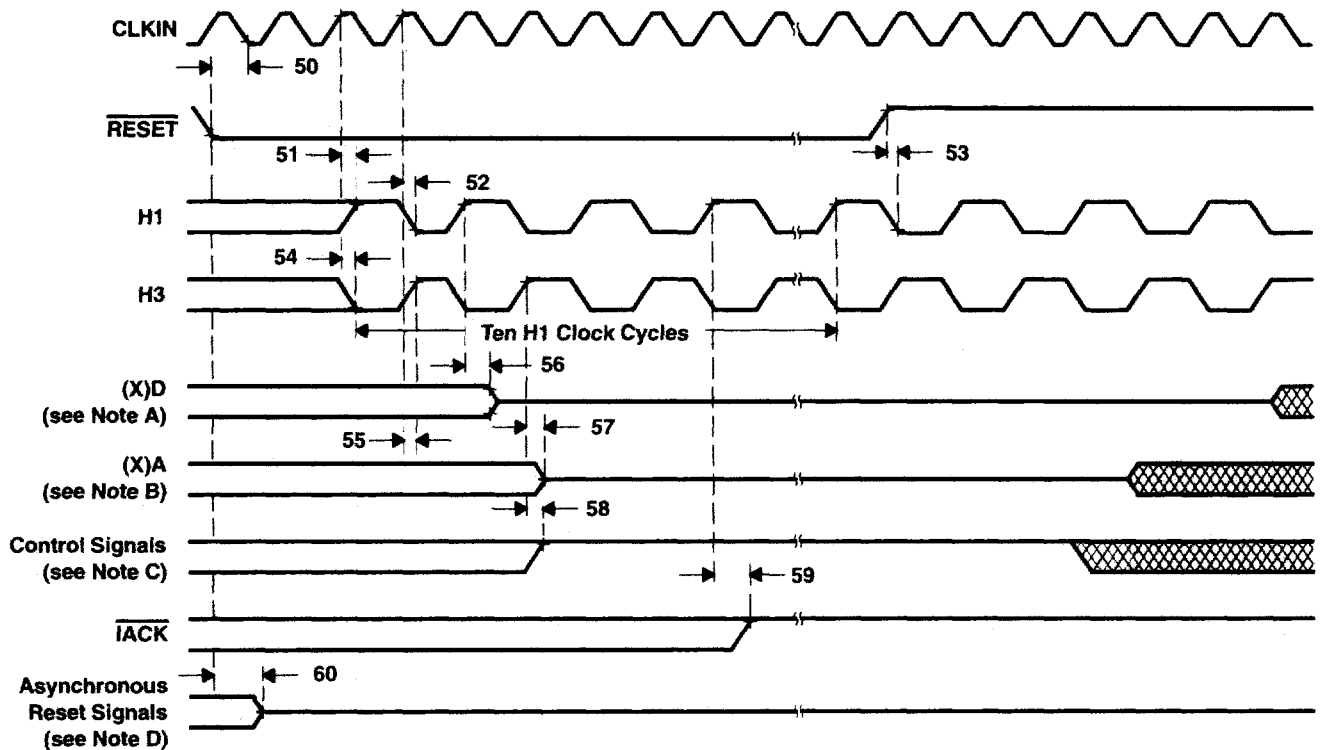

- NOTES: A. In this diagram X(D) includes D31-D0 and XD31-XD0.
 B. In this diagram, (X)A includes A23-A0 and XA12-XA0.
 C. Control signals include $\overline{\text{STRB}}$, $\overline{\text{MSTRB}}$, and $\overline{\text{IOSTRB}}$.
 D. Asynchronous reset signals include XF1, XF0, CLKX0, DX0, FSX0, CLKR0, DR0, FSR0, CLKX1, DX1, FSX1, CLKR1, DR1, FSR1, TCLK0, and TCLK1.
 E. In microprocessor mode, the reset vector is fetched twice, with seven software wait states each time. In microcomputer mode, the reset vector is fetched twice, with no software wait states.

Figure 20. Timing for $\overline{\text{Reset}}$ [$P=t_c(C1)$]

SMJ320C30 DIGITAL SIGNAL PROCESSOR

SGUS014C – FEBRUARY 1991 – REVISED MARCH 1998

interrupt-response timing

The following table defines the timing parameters for the $\overline{\text{INT}}$ signals.

timing parameters for $\overline{\text{INT3}}-\overline{\text{INT0}}$ [$Q = t_{c(H)}$] (see Figure 21)

NO.			'320C30-33		'320C30-40		'320C30-50		UNIT
			MIN	MAX	MIN	MAX	MIN	MAX	
61	$t_{su}(\text{INT})$	Setup time, $\overline{\text{INT3}}-\overline{\text{INT0}}$ before H1 low	15		13		10		ns
62	$t_w(\text{INT})$	Pulse duration, $\overline{\text{INT3}}-\overline{\text{INT0}}$, to assure only one interrupt seen	Q	$< 2Q^*$	Q	$< 2Q^*$	Q	$< 2Q^*$	ns

* This parameter is not production tested.

The interrupt ($\overline{\text{INT}}$) pins are asynchronous inputs that can be asserted at any time during a clock cycle. The SMJ320C30 interrupts are level-sensitive, not edge-sensitive. Interrupts are detected on the falling edge of H1. Therefore, interrupts must be set up and held to the falling edge of H1 for proper detection. The CPU and DMA respond to detected interrupts on instruction-fetch boundaries only.

For the processor to recognize only one interrupt on a given input, an interrupt pulse must be set up and held to:

- A minimum of one H1 falling edge
- No more than two H1 falling edges

The SMJ320C30 can accept an interrupt from the same source every two H1 clock cycles.

If the specified timings are met, the exact sequence shown in Figure 21 occurs; otherwise, an additional delay of one clock cycle is possible.

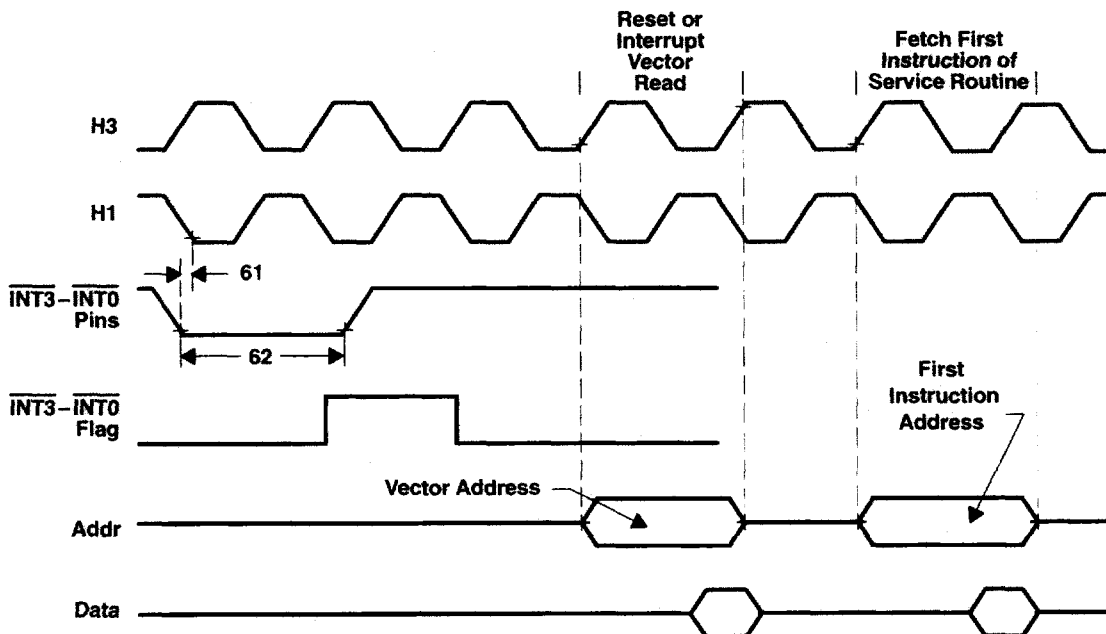

Figure 21. Timing for $\overline{\text{INT3}}-\overline{\text{INT0}}$ Response [$Q = t_{c(H)}$]

interrupt-acknowledge timing

The $\overline{\text{IACK}}$ output goes active on the first half-cycle (H1 rising) of the decode phase of the IACK instruction and goes inactive at the first half-cycle (H1 rising) of the read phase of the IACK instruction.

The following table defines the timing parameters for the $\overline{\text{IACK}}$ signal.

timing parameters for $\overline{\text{IACK}}$ (see Figure 22)

NO.T		'320C30-33		'320C30-40		'320C30-50		UNIT
		MIN	MAX	MIN	MAX	MIN	MAX	
63	$t_d(\text{H1H-IACKL})$ Delay time, H1 high to $\overline{\text{IACK}}$ low		10		9		7	ns
64	$t_d(\text{H1H-IACKH})$ Delay time, H1 high to $\overline{\text{IACK}}$ high		10		9		7	ns

† Numbers in this column match those used in Figure 22.

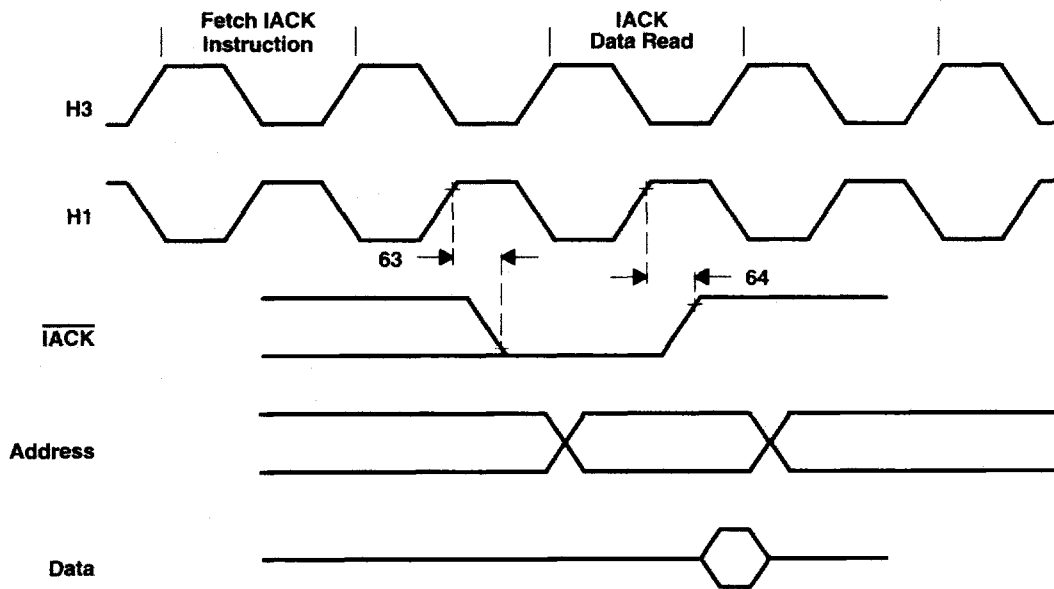

Figure 22. Timing for Interrupt-Acknowledge ($\overline{\text{IACK}}$)

SMJ320C30 DIGITAL SIGNAL PROCESSOR

SGUS014C - FEBRUARY 1991 - REVISED MARCH 1998

serial-port timing parameters (see Figure 23 and Figure 24)

NO.	CLOCK SOURCE	'320C30-33		'320C30-40		UNIT
		MIN	MAX	MIN	MAX	
65	$t_d(H1-SCK)$ Delay time, H1 high to internal CLKX/R		15		13	ns
66	$t_c(SCK)$ Cycle time, CLKX/R	$t_c(H) \times 2.5^*$		$t_c(H) \times 2.5^*$		ns
		$t_c(H) \times 2$	$t_c(H) \times 2^{32}$	$t_c(H) \times 2$	$t_c(H) \times 2^{32}$	
67	$t_w(SCK)$ Pulse duration, CLKX/R high/low	$t_c(H) + 12^*$		$t_c(H) + 12^*$		ns
		$\lceil t_c(SCK) / 2 \rceil - 15$	$\lceil t_c(SCK) / 2 \rceil + 5$	$\lceil t_c(SCK) / 2 \rceil - 15$	$\lceil t_c(SCK) / 2 \rceil + 5$	
68	$t_r(SCK)$ Rise time, CLKX/R		8^*		7^*	ns
69	$t_f(SCK)$ Fall time, CLKX/R		8^*		7^*	ns
70	$t_d(DX)$ Delay time, CLKX to DX valid		35		30	ns
			20		17	
71	$t_{su}(DR)$ Setup time, DR before CLKR low	CLKR ext		10	9	ns
		CLKR int		25	21	
72	$t_h(DR)$ Hold time, DR from CLKR low	CLKR ext		10	9	ns
		CLKR int		0*	0	
73	$t_d(FSX)$ Delay time, CLKX to internal FSX high/low	CLKX ext		32	27	ns
		CLKX int		17	15	
74	$t_{su}(FSR)$ Setup time, FSR before CLKR low	CLKR ext		10	9	ns
		CLKR int		10	9	
75	$t_h(FS)$ Hold time, FSX/R input from CLKX/R low	CLKX/R ext		10	9	ns
		CLKX/R int		0	0	
76	$t_{su}(FSX)$ Setup time, external FSX before CLKX high	CLKX ext	$-\lceil t_c(H) - 8 \rceil$	$\lceil t_c(SCK) / 2 \rceil - 10^*$	$\lceil t_c(SCK) / 2 \rceil - 10^*$	ns
		CLKX int	$-\lceil t_c(H) - 2 \rceil$	$t_c(SCK) / 2^*$	$t_c(SCK) / 2^*$	
77	$t_d(CH-DX)V$ Delay time, CLKX to first DX bit, FSX precedes CLKX high	CLKX ext		36	30	ns
		CLKX int		21	18	
78	$t_d(FSX-DX)V$ Delay time, FSX to first DX bit, CLKX precedes FSX		36		30	ns
79	t_dDXZ Delay time, CLKX high to DX high impedance following last data bit		20^*		17^*	ns

* This parameter is not production tested.



serial-port timing parameters (see Figure 23 and Figure 24) (continued)

NO.	CLOCK SOURCE	'320C30-50		UNIT
		MIN	MAX	
65	$t_d(H1-SCK)$ Delay time, H1 high to internal CLKX/R		10	ns
66	$t_c(SCK)$ Cycle time, CLKX/R	$t_c(H) \times 2.6^*$		ns
		$t_c(H) \times 2$	$t_c(H) \times 232^*$	
67	$t_w(SCK)$ Pulse duration, CLKX/R high/low	$t_c(H) + 10^*$		ns
		$[t_c(SCK)/2] - 5$	$[t_c(SCK)/2] + 5$	
68	$t_r(SCK)$ Rise time, CLKX/R		6*	ns
69	$t_f(SCK)$ Fall time, CLKX/R		6*	ns
70	$t_d(DX)$ Delay time, CLKX to DX valid		24	ns
			16	
71	$t_{su}(DR)$ Setup time, DR before CLKR low		9	ns
			17	
72	$t_h(DR)$ Hold time, DR from CLKR low		7	ns
			0	
73	$t_d(FSX)$ Delay time, CLKX to internal FSX high/low		22	ns
			15	
74	$t_{su}(FSR)$ Setup time, FSR before CLKR low		7	ns
			7	
75	$t_h(FS)$ Hold time, FSX/R input from CLKX/R low		7	ns
			0	
76	$t_{su}(FSX)$ Setup time, external FSX before CLKX high		$[t_c(SCK)/2] - 10^*$	ns
			$-[t_c(H) - 21]$	
77	$t_d(CH-DX)V$ Delay time, CLKX to first DX bit, FSX precedes CLKX high		24	ns
			14	
78	$t_d(FSX-DX)V$ Delay time, FSX to first DX bit, CLKX precedes FSX		24	ns
79	t_dDXZ Delay time, CLKX high to DX high impedance following last data bit		14*	ns

* This parameter is not production tested.

SMJ320C30 DIGITAL SIGNAL PROCESSOR

SGUS014C – FEBRUARY 1991 – REVISED MARCH 1998

serial-port timing parameters (continued)

Unless otherwise indicated, the data-rate timings shown in Figure 23 and Figure 24 are valid for all serial-port modes, including handshake. See serial-port timing parameter tables.

Timing diagrams shown in Figure 23 and Figure 24 show operations with the serial port global-control register bits CLKXP = CLKRP = FSXP = FSRP = 0.

Timing diagrams shown in Figure 23 and Figure 24 depend upon the length of the serial-port word, n , where $n = 8, 16, 24,$ or 32 bits, respectively.

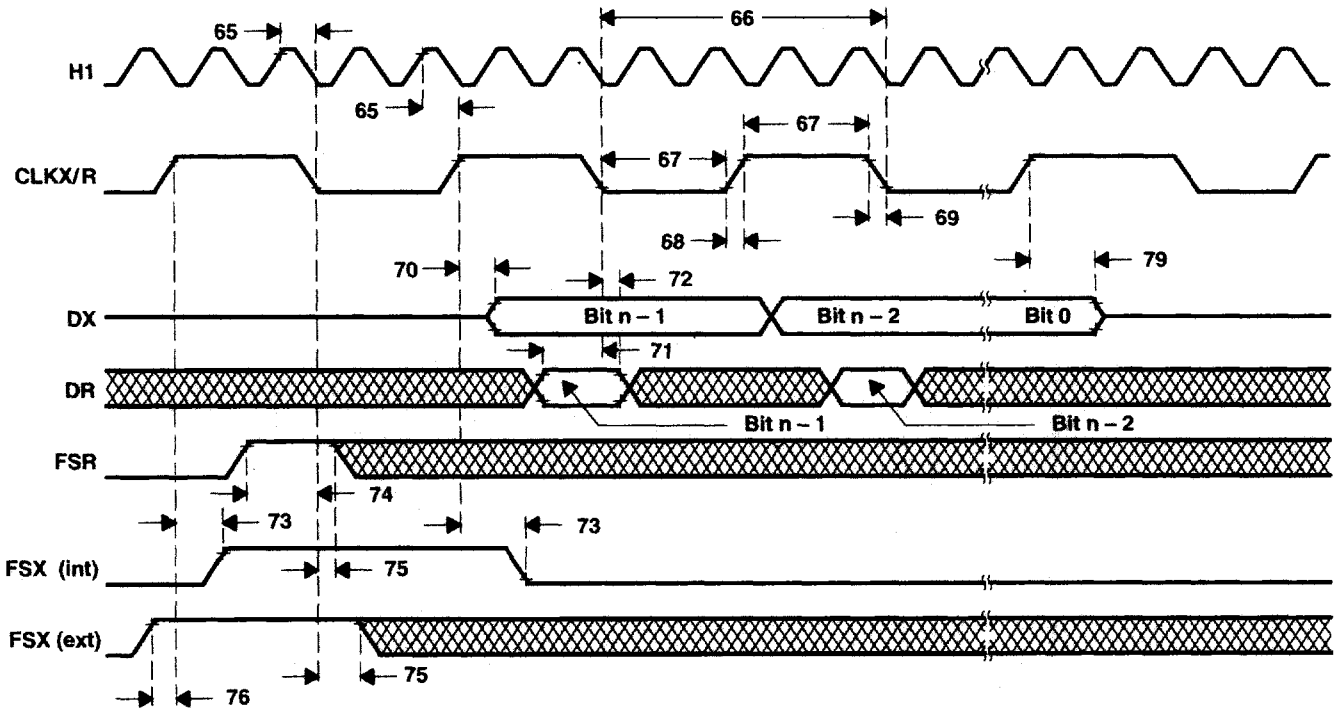
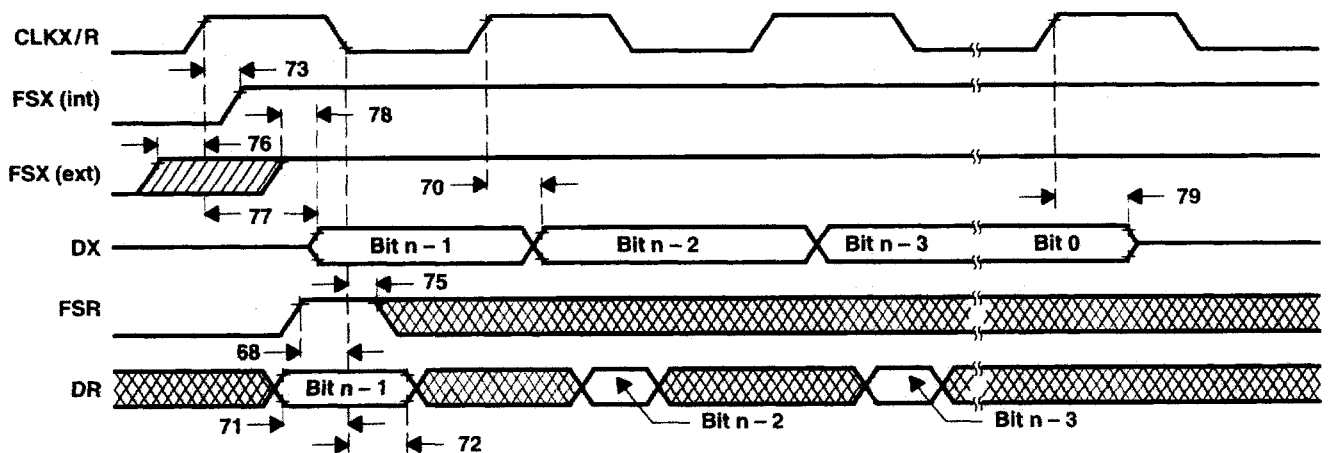

Figure 23. Serial-Port Timing for Fixed-Data-Rate Mode



NOTE A: Timings not expressly specified for variable-data-rate mode are the same as those for fixed-data-rate mode.

Figure 24. Serial-Port Timing for Variable-Data-Rate Mode



HOLD timing

$\overline{\text{HOLD}}$ is an asynchronous input that can be asserted at any time during a clock cycle. If the specified timings are met, the exact sequence shown in Figure 25 occurs; otherwise, an additional delay of one clock cycle is possible.

The "timing parameters for $\overline{\text{HOLD}}/\overline{\text{HOLDA}}$ " table defines the timing parameters for the $\overline{\text{HOLD}}$ and $\overline{\text{HOLDA}}$ signals.

The NOHOLD bit of the primary bus control register overrides the $\overline{\text{HOLD}}$ signal. When this bit is set, the device comes out of hold and prevents future hold cycles.

Asserting $\overline{\text{HOLD}}$ prevents the processor from accessing the primary bus. Program execution continues until a read from or a write to the primary bus is requested. In certain circumstances, the first write is pending, allowing the processor to continue until a second write is encountered.

HOLD/HOLDA timing (see Figure 25)

NO.T		'320C30-33		'320C30-40		'320C30-50		UNIT
		MIN	MAX	MIN	MAX	MIN	MAX	
80	$t_{su}(\overline{\text{HOLD}})$ Setup time, $\overline{\text{HOLD}}$ before H1 low	15		13		10		ns
81	$t_v(\overline{\text{HOLDA}})$ Valid time, $\overline{\text{HOLDA}}$ after H1 low	0*	10	0*	9	0*	7	ns
82	$t_w(\overline{\text{HOLD}})$ Pulse duration, $\overline{\text{HOLD}}$ low	$2t_{c(H)}$		$2t_{c(H)}$		$2t_{c(H)}$		ns
83	$t_w(\overline{\text{HOLDA}})$ Pulse duration, $\overline{\text{HOLDA}}$ low	$t_{c(H)} - 5^*$		$t_{c(H)} - 5^*$		$t_{c(H)} - 5^*$		ns
84	$t_d(\text{H1L-SH})\text{H}$ Delay time, H1 low to $\overline{\text{STRB}}$ high for a $\overline{\text{HOLD}}$	0*	10*	0*	9*	0*	7*	ns
85	$t_{dis}(\text{H1L-S})$ Disable time, H1 low to $\overline{\text{STRB}}$ high impedance	0*	10*	0*	9*	0*	8*	ns
86	$t_{en}(\text{H1L-S})$ Enable time, H1 low to $\overline{\text{STRB}}$ active	0*	10*	0*	9*	0*	7*	ns
87	$t_{dis}(\text{H1L-RW})$ Disable time, H1 low to R/ $\overline{\text{W}}$ high impedance	0*	10*	0*	9*	0*	8*	ns
88	$t_{en}(\text{H1L-RW})$ Enable time, H1 low to R/ $\overline{\text{W}}$ active	0*	10*	0*	9*	0*	7*	ns
89	$t_{dis}(\text{H1L-A})$ Disable time, H1 low to address high impedance	0*	10*	0*	9*	0*	8*	ns
90	$t_{en}(\text{H1L-A})$ Enable time, H1 low to address valid	0*	15*	0*	13*	0*	12*	ns
91	$t_{dis}(\text{H1H-D})$ Disable time, H1 high to data high impedance	0*	15*	0*	12*	0*	8*	ns

† Numbers in this column are used in Figure 25.

* This parameter is not production tested.

SMJ320C30 DIGITAL SIGNAL PROCESSOR

SGUS014C – FEBRUARY 1991 – REVISED MARCH 1998

HOLD/HOLDA timing (continued)

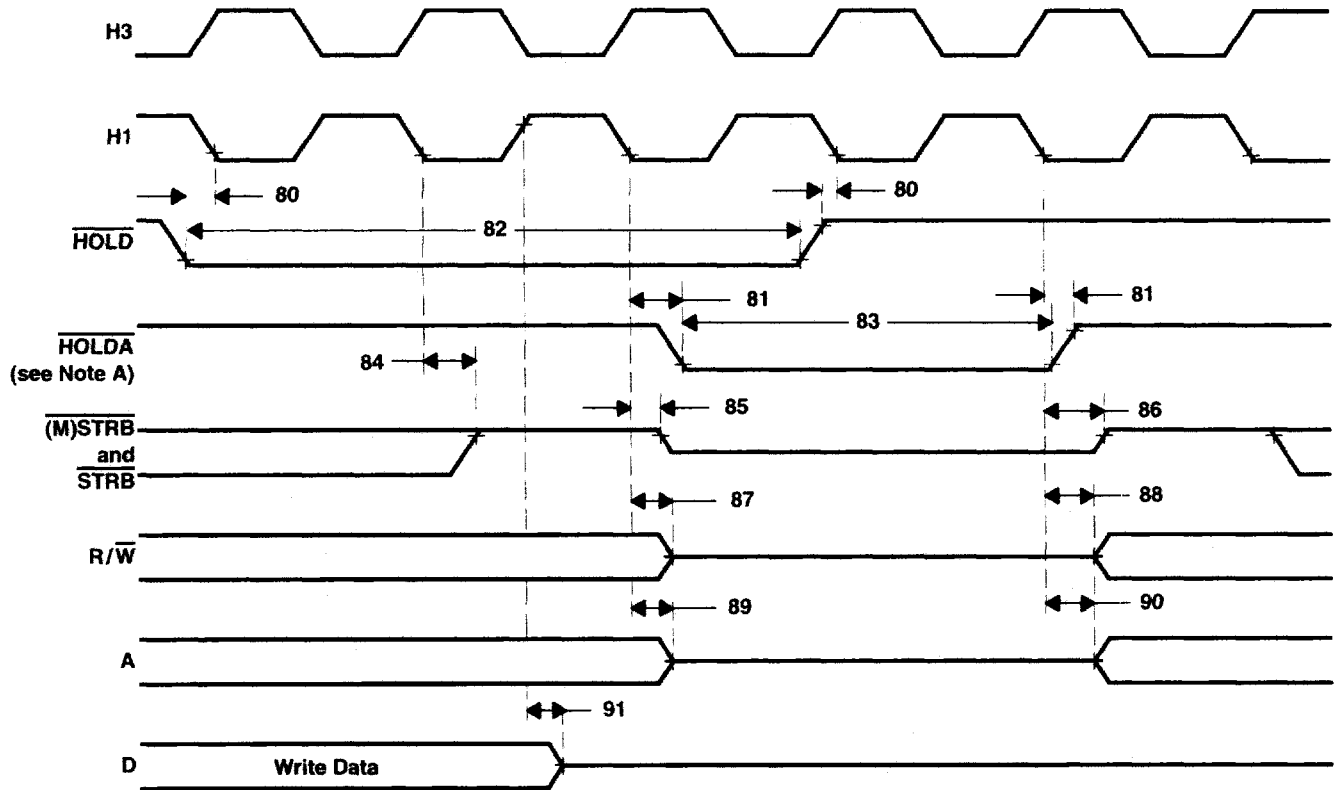

NOTE A: $\overline{\text{HOLDA}}$ goes low in response to $\overline{\text{HOLD}}$ going low and continues to remain low through one H1 cycle after $\overline{\text{HOLD}}$ returns to high.

Figure 25. Timing for $\overline{\text{HOLD}}/\overline{\text{HOLDA}}$



POST OFFICE BOX 1443 • HOUSTON, TEXAS 77251-1443

general-purpose I/O timing

Peripheral pins include CLKX0/1, CLKR0/1, DX0/1, DR0/1, FSX0/1, FSR0/1, and TCLK0/1. The contents of the internal-control registers associated with each peripheral define the modes for these pins.

peripheral pin I/O timing

The following table defines peripheral pin general-purpose I/O timing parameters.

timing parameters for peripheral pin general-purpose I/O (see Note 10 and Figure 26)

NO.T		'320C30-33		'320C30-40		'320C30-50		UNIT
		MIN	MAX	MIN	MAX	MIN	MAX	
92	$t_{su}(GPIOH1L)$ Setup time, general-purpose input before H1 low	12*		10*		9*		ns
93	$t_h(GPIOH1L)$ Hold time, general-purpose input after H1 low	0*		0*		0*		ns
94	$t_d(GPIOH1H)$ Delay time, general-purpose output after H1 high		15*		13*		10*	ns

† Numbers in this column are used in Figure 26.

* This parameter is not production tested.

NOTE 10: Peripheral pins include CLKX0/1, CLKR0/1, DX0/1, DR0/1, FSX0/1, FSR0/1, and TCLK0/1. The modes of these pins are defined by the contents of internal control registers associated with each peripheral.

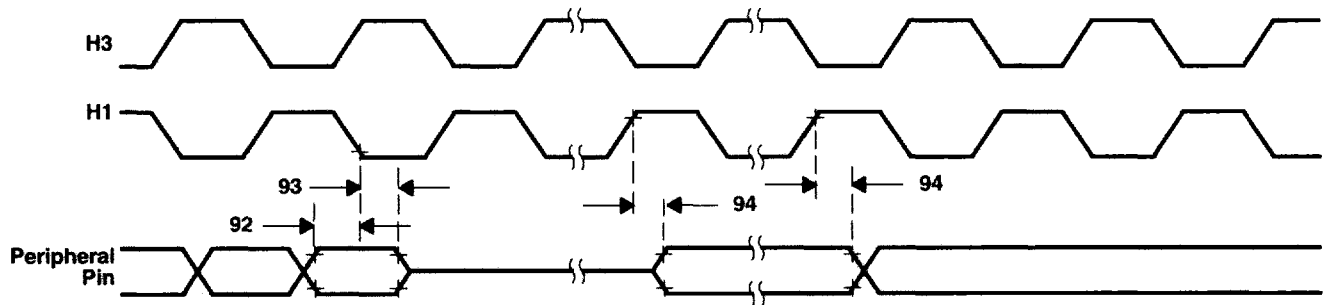

Figure 26. Timing for Peripheral Pin General-Purpose I/O

SMJ320C30 DIGITAL SIGNAL PROCESSOR

SGUS014C – FEBRUARY 1991 – REVISED MARCH 1998

changing the peripheral pin I/O modes

The following tables show the timing parameters for changing the peripheral pin from a general-purpose output pin to a general-purpose input pin and the reverse.

timing parameters for peripheral pin changing from general-purpose output to input mode (see Note 11 and Figure 27)

NO.T			'320C30-33		'320C30-40		'320C30-50		UNIT
			MIN	MAX	MIN	MAX	MIN	MAX	
95	$t_{h(H1H)}$	Hold time after H1 high		15		13		10	ns
96	$t_{su}(GPIOH1L)$	Setup time, peripheral pin before H1 low	12		9		9		ns
97	$t_{h}(GPIOH1L)$	Hold time, peripheral pin after H1 low	0		0		0		ns

† Numbers in this column are used in Figure 27.

NOTE 11: Peripheral pins include CLKX0/1, CLKR0/1, DX0/1, DR0/1, FSX0/1, FSR0/1, and TCLK0/1. The modes of these pins are defined by the contents of internal control registers associated with each peripheral.

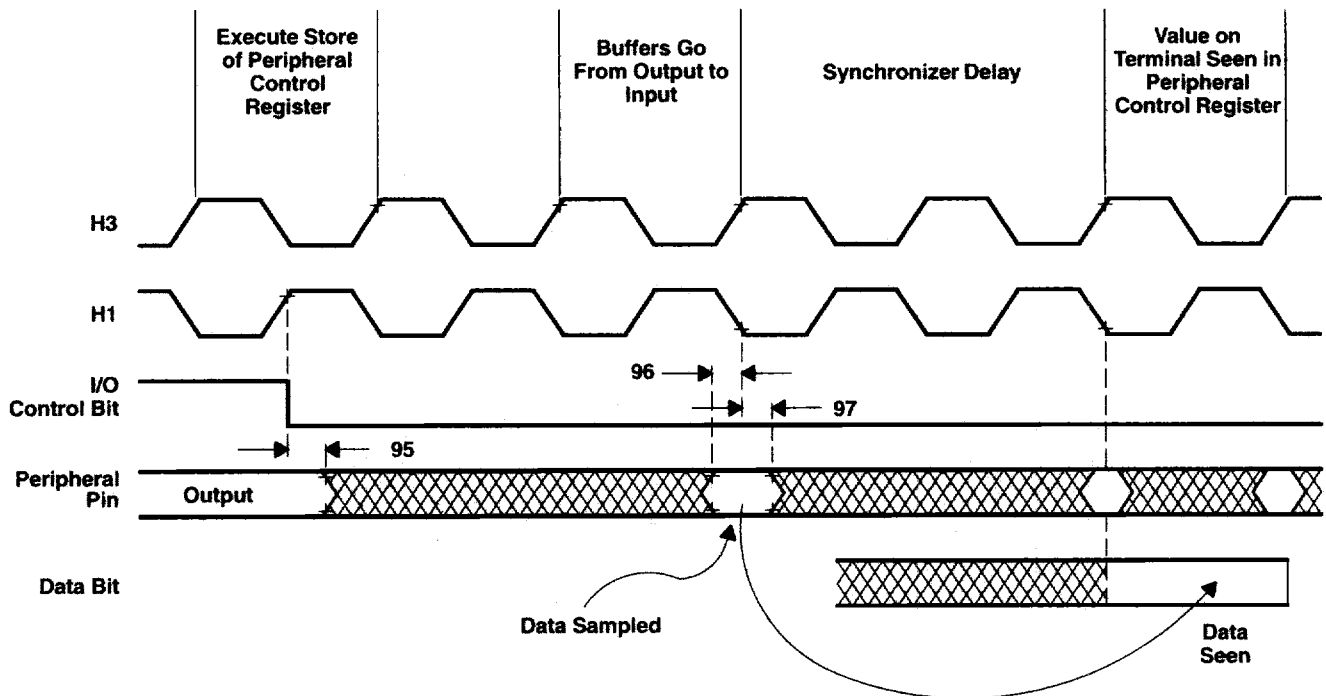

Figure 27. Timing for Change of Peripheral Pin From General-Purpose Output to Input Mode

timing parameters for peripheral pin changing from general-purpose input to output mode (see Figure 28)

NO.		'320C30-33		'320C30-40		'320C30-50		UNIT
		MIN	MAX	MIN	MAX	MIN	MAX	
98	$t_d(\text{GPIOH1H})$ Delay time, H1 high to peripheral pin switching from input to output		15		13		10	ns

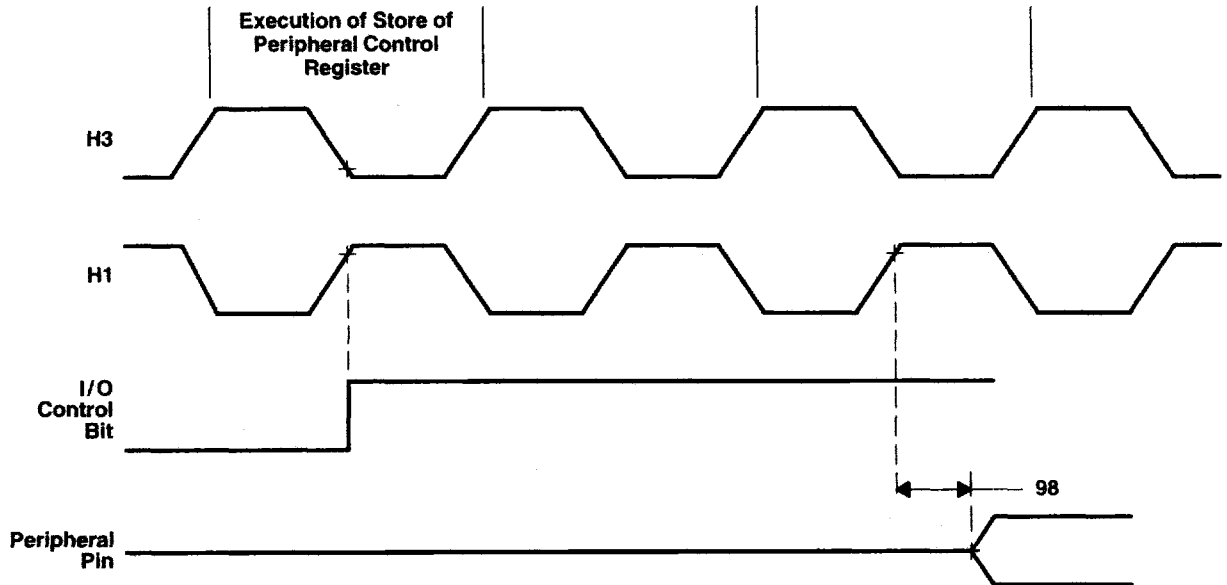

Figure 28. Timing for Change of Peripheral Pin From General-Purpose Input to Output Mode

SMJ320C30 DIGITAL SIGNAL PROCESSOR

SGUS014C – FEBRUARY 1991 – REVISED MARCH 1998

timer pin (TCLK0 and TCLK1) timing

Valid logic-level periods and polarity are specified by the contents of the internal control registers.

The following tables define the timing parameters for the timer pin.

timing parameters for timer pin (TCLK0 and TCLK1) (see Figure 29)

NO.T			'320C30-33†		UNIT
			MIN	MAX	
99	$t_{su}(TCLK-H1L)$	Setup time, TCLK ext before H1 low	TCLK ext	12	ns
100	$t_h(TCLK-H1L)$	Hold time, TCLK ext after H1 low	TCLK ext	0	ns
101	$t_d(TCLK-H1H)$	Delay time, H1 high to TCLK int valid	TCLK int	12	ns
102	$t_c(TCLK)$	Cycle time, TCLK	TCLK ext	$t_c(H) \times 2.6^*$	ns
			TCLK int	$t_c(H) \times 2$ $t_c(H) \times 2^{32^*}$	ns
103	$t_w(TCLK)$	Pulse duration, TCLK high/low	TCLK ext	$t_c(H) + 12^*$	ns
			TCLK int	$\lceil t_c(TCLK)/2 \rceil - 15$ $\lceil t_c(TCLK)/2 \rceil + 5$	ns

NO.			'320C30-40†		UNIT
			MIN	MAX	
99	$t_{su}(TCLK-H1L)$	Setup time, TCLK ext before H1 low	TCLK ext	10	ns
100	$t_h(TCLK-H1L)$	Hold time, TCLK ext after H1 low	TCLK ext	0	ns
101	$t_d(TCLK-H1H)$	Delay time, H1 high to TCLK int valid	TCLK int	9	ns
102	$t_c(TCLK)$	Cycle time, TCLK	TCLK ext	$t_c(H) \times 2.6^*$	ns
			TCLK int	$t_c(H) \times 2$ $t_c(H) \times 2^{32^*}$	ns
103	$t_w(TCLK)$	Pulse duration, TCLK high/low	TCLK ext	$t_c(H) + 12^*$	ns
			TCLK int	$\lceil t_c(TCLK)/2 \rceil - 5$ $\lceil t_c(TCLK)/2 \rceil + 5$	ns

NO.			'320C30-50†		UNIT
			MIN	MAX	
99	$t_{su}(TCLK-H1L)$	Setup time, TCLK ext before H1 low	TCLK ext	8	ns
100	$t_h(TCLK-H1L)$	Hold time, TCLK ext after H1 low	TCLK ext	0	ns
101	$t_d(TCLK-H1H)$	Delay time, H1 high to TCLK int valid	TCLK int	9	ns
102	$t_c(TCLK)$	Cycle time, TCLK	TCLK ext	$t_c(H) \times 2.6^*$	ns
			TCLK int	$t_c(H) \times 2$ $t_c(H) \times 2^{32^*}$	ns
103	$t_w(TCLK)$	Pulse duration, TCLK high/low	TCLK ext	$t_c(H) + 10^*$	ns
			TCLK int	$\lceil t_c(TCLK)/2 \rceil - 5$ $\lceil t_c(TCLK)/2 \rceil + 5$	ns

† Numbers in this column are used in Figure 29.

‡ Timing parameters 99 and 100 are applicable for a synchronous input clock. Timing parameters 102 and 103 are applicable for an asynchronous input clock.

* This parameter is not production tested.



timer pin (TCLK0 and TCLK1) timing (continued)

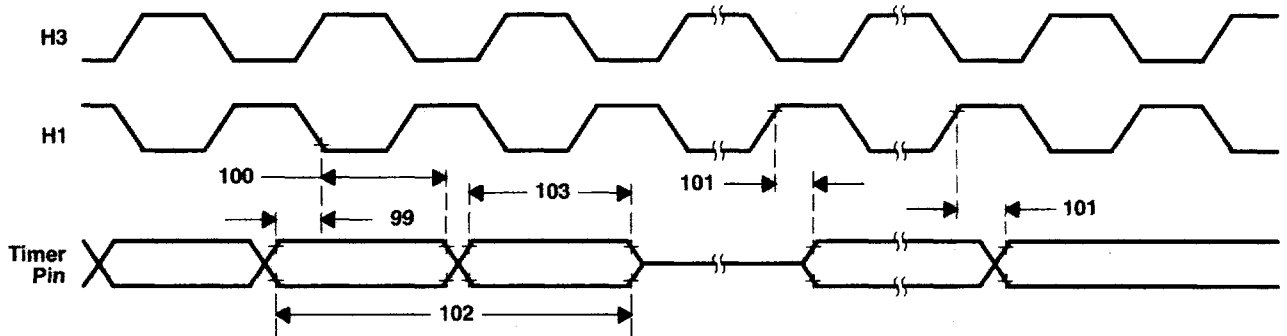

NOTE A: Period and polarity of valid logic level are specified by contents of internal control registers.

Figure 29. Timing for Timer Pin

$\overline{\text{SHZ}}$ pin timing

The following table defines the timing parameter for the $\overline{\text{SHZ}}$ pin.

timing parameters for $\overline{\text{SHZ}}$ pin (see Figure 30)

NO.T		'320C30-33 '320C30-40 '320C30-50		UNIT
		MIN	MAX	
104	$t_{\text{dis}}(\overline{\text{SHZ}})$ Disable time, $\overline{\text{SHZ}}$ low to all O, I/O high impedance	0*	3P + 15*	ns
105	$t_{\text{en}}(\overline{\text{SHZ}})$ Enable time, $\overline{\text{SHZ}}$ high to all O, I/O active	0*	2P*	ns

† Numbers in this column are used in Figure 30.

* This parameter is not production tested.

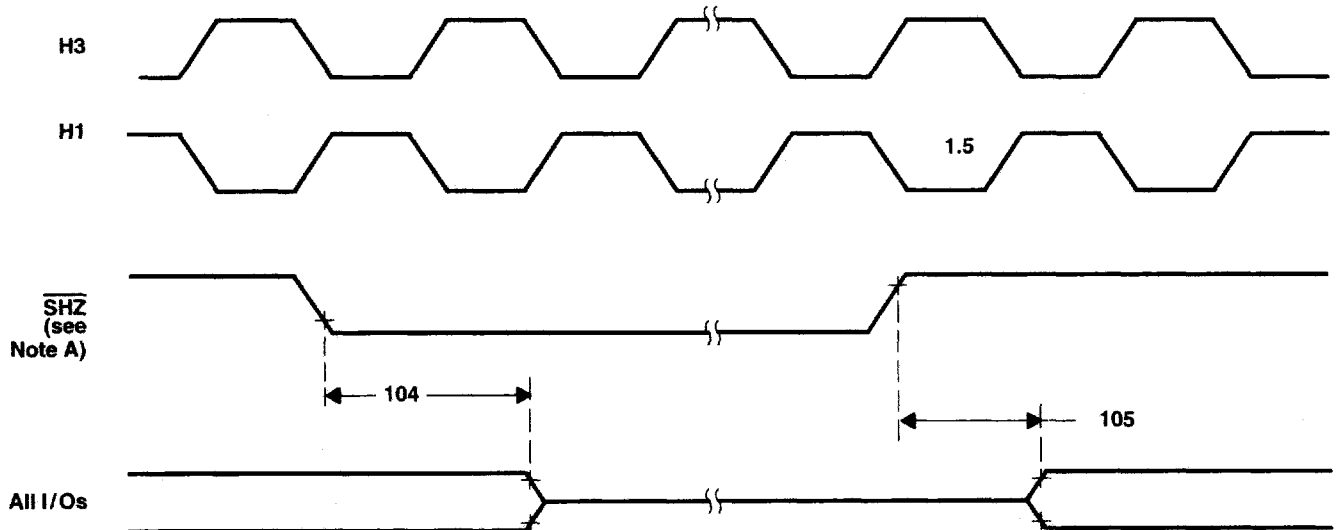

NOTE A: Enabling $\overline{\text{SHZ}}$ destroys SMJ320C30 register and memory contents. Assert $\overline{\text{SHZ}}$ and reset the SMJ320C30 to restore it to a known condition.

Figure 30. Timing for $\overline{\text{SHZ}}$

SMJ320C30 DIGITAL SIGNAL PROCESSOR

SGUS014C – FEBRUARY 1991 – REVISED MARCH 1998

SMJ320C30 part order information

DEVICE	TECHNOLOGY	POWER SUPPLY	OPERATING FREQUENCY	PACKAGE TYPE	PROCESSING LEVEL
SMJ320C30GBM33	0.7- μ m CMOS	5 V \pm 10%	33 MHz	Ceramic 181-pin PGA	QML
SM320C30GBM33	0.7- μ m CMOS	5 V \pm 10%	33 MHz	Ceramic 181-pin PGA	Standard
SMJ320C30HFGM33	0.7- μ m CMOS	5 V \pm 10%	33 MHz	Ceramic 196-pin quad flatpack with nonconductive tie bar	QML
SM320C30HFGM33	0.7- μ m CMOS	5 V \pm 10%	33 MHz	Ceramic 196-pin quad flatpack with nonconductive tie bar	Standard
5962-9052603MXA	0.7- μ m CMOS	5 V \pm 10%	33 MHz	Ceramic 181-pin PGA	DESC SMD
5962-9052603MUA	0.7- μ m CMOS	5 V \pm 10%	33 MHz	Ceramic 196-pin quad flatpack with nonconductive tie bar	DESC SMD
SMJ320C30GBM40	0.7- μ m CMOS	5 V \pm 5%	40 MHz	Ceramic 181-pin PGA	QML
SM320C30GBM40	0.7- μ m CMOS	5 V \pm 5%	40 MHz	Ceramic 181-pin PGA	Standard
SMJ320C30HFGM40	0.7- μ m CMOS	5 V \pm 5%	40 MHz	Ceramic 196-pin quad flatpack with nonconductive tie bar	QML
SM320C30HFGM40	0.7- μ m CMOS	5 V \pm 5%	40 MHz	Ceramic 196-pin quad flatpack with nonconductive tie bar	Standard
5962-9052604MXA	0.7- μ m CMOS	5 V \pm 5%	40 MHz	Ceramic 181-pin PGA	DESC SMD
5962-9052604MUA	0.7- μ m CMOS	5 V \pm 5%	40 MHz	Ceramic 196-pin quad flatpack with nonconductive tie bar	DESC SMD
SMJ320C30GBM50	0.7- μ m CMOS	5 V \pm 5%	50 MHz	Ceramic 181-pin PGA	QML
SM320C30GBM50	0.7- μ m CMOS	5 V \pm 5%	50 MHz	Ceramic 181-pin PGA	Standard
SMJ320C30HFGM50	0.7- μ m CMOS	5 V \pm 5%	50 MHz	Ceramic 196-pin quad flatpack with nonconductive tie bar	QML
SM320C30HFGM50	0.7- μ m CMOS	5 V \pm 5%	50 MHz	Ceramic 196-pin quad flatpack with nonconductive tie bar	Standard
5962-9052605MXA	0.7- μ m CMOS	5 V \pm 5%	50 MHz	Ceramic 181-pin PGA	DESC SMD
5962-9052605MUA	0.7- μ m CMOS	5 V \pm 5%	50 MHz	Ceramic 196-pin quad flatpack with nonconductive tie bar	DESC SMD

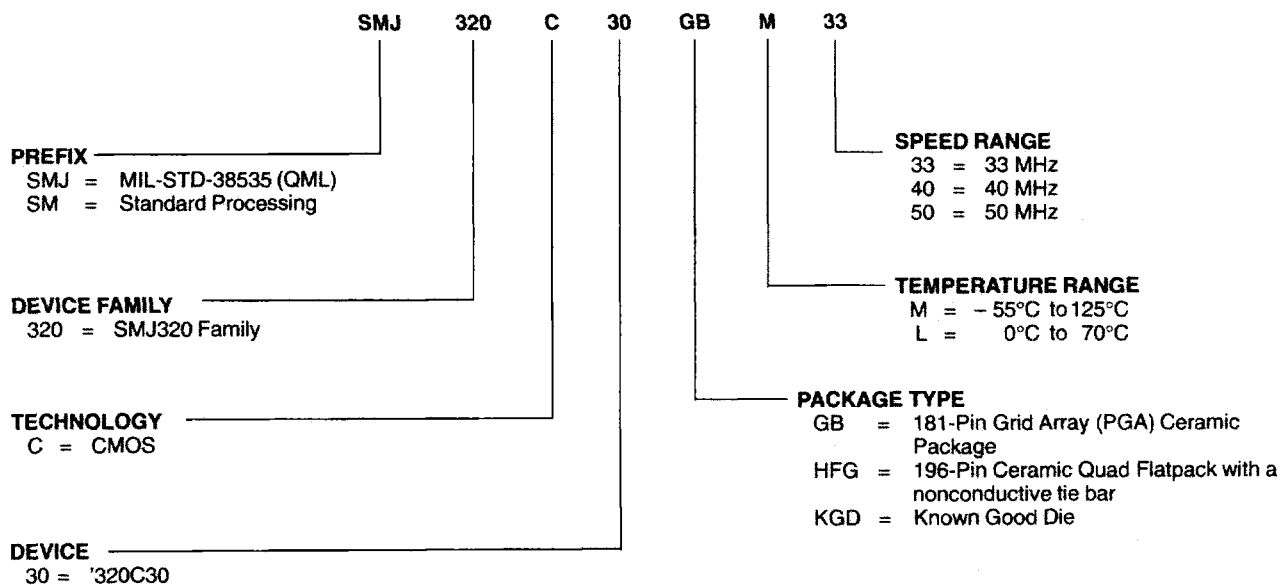

Figure 31. SMJ320C30 Device Nomenclature



SMJ320C30 DIGITAL SIGNAL PROCESSOR

SGUS014C - FEBRUARY 1991 - REVISED MARCH 1998

HFG (S-CQFP-F196)

MECHANICAL DATA

CERAMIC QUAD FLATPACK WITH TIE BAR

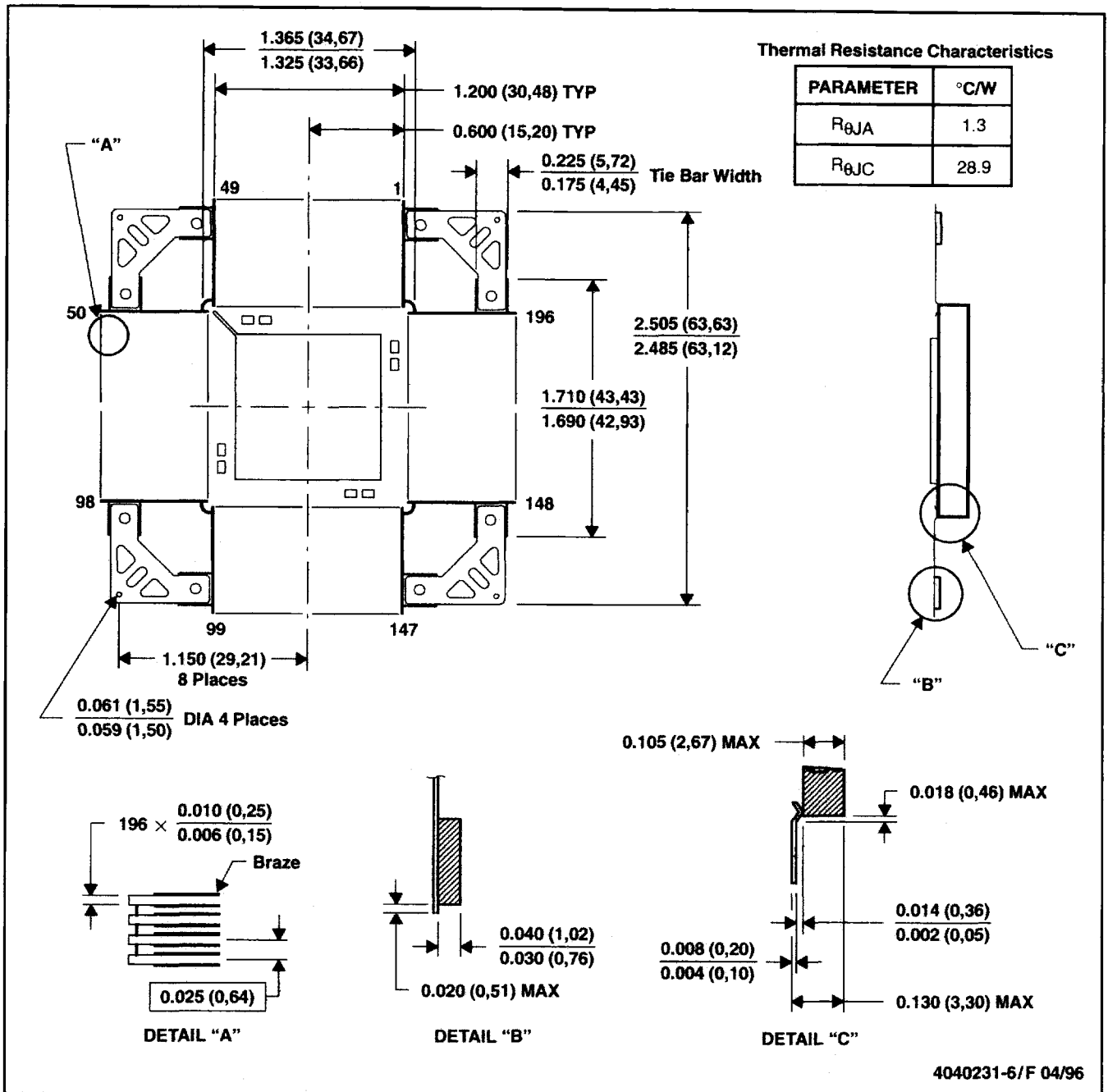

- NOTES:
- A. All linear dimensions are in inches (millimeters).
 - B. This drawing is subject to change without notice.
 - C. Ceramic quad flatpack with flat leads brazed to nonconductive tie-bar carrier
 - D. This package can be hermetically sealed with a metal lid.
 - E. The terminals will be gold plated.
 - F. Falls within JEDEC MO-113 AB

The above data applies to the SMJ320C30 196-pin QFP.



POST OFFICE BOX 1443 • HOUSTON, TEXAS 77251-1443

SMJ320C30 DIGITAL SIGNAL PROCESSOR

SGUS014C - FEBRUARY 1991 - REVISED MARCH 1998

MECHANICAL DATA

GA-GB (S-CPGA-P15 X 15)

CERAMIC PIN GRID ARRAY PACKAGE

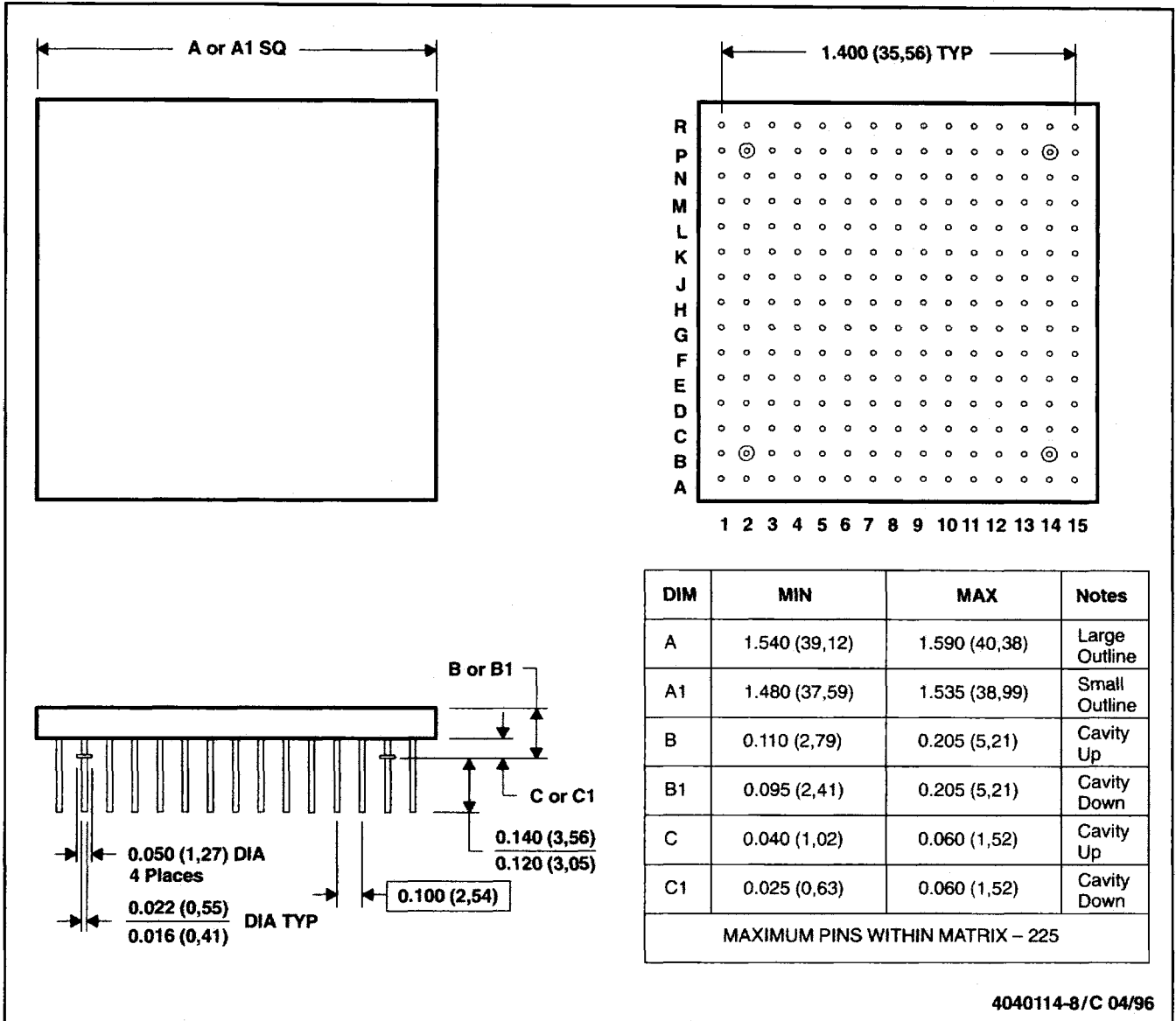

- NOTES: A. All linear dimensions are in inches (millimeters).
 B. This drawing is subject to change without notice.
 C. Index mark may appear on top or bottom depending on package vendor.
 D. Pins are located within 0.010 (0,25) diameter of true position relative to each other at maximum material condition and with n 0.030 (0,76) diameter relative to the edges of the ceramic.
 E. This package can be hermetically sealed with metal lids or with ceramic lids using glass frit.
 F. The pins can be gold plated or solder dipped.
 G. Falls within MIL-STD-1835 CMGA7-PN and CMGA19-PN and JEDEC MO-067AG and MO-066AG, respectively

Thermal Resistance Characteristics

PARAMETER	°C/W
R _{θJA}	1.1
R _{θJC}	26.6

The above data applies to the SMJ320C30 181-pin PGA.



POST OFFICE BOX 1443 • HOUSTON, TEXAS 77251-1443

IMPORTANT NOTICE

Texas Instruments (TI) reserves the right to make changes to its products or to discontinue any semiconductor product or service without notice, and advises its customers to obtain the latest version of relevant information to verify, before placing orders, that the information being relied on is current and complete.

TI warrants performance of its semiconductor products and related software to the specifications applicable at the time of sale in accordance with TI's standard warranty. Testing and other quality control techniques are utilized to the extent TI deems necessary to support this warranty. Specific testing of all parameters of each device is not necessarily performed, except those mandated by government requirements.

Certain applications using semiconductor products may involve potential risks of death, personal injury, or severe property or environmental damage ("Critical Applications").

TI SEMICONDUCTOR PRODUCTS ARE NOT DESIGNED, INTENDED, AUTHORIZED, OR WARRANTED TO BE SUITABLE FOR USE IN LIFE-SUPPORT APPLICATIONS, DEVICES OR SYSTEMS OR OTHER CRITICAL APPLICATIONS.

Inclusion of TI products in such applications is understood to be fully at the risk of the customer. Use of TI products in such applications requires the written approval of an appropriate TI officer. Questions concerning potential risk applications should be directed to TI through a local SC sales office.

In order to minimize risks associated with the customer's applications, adequate design and operating safeguards should be provided by the customer to minimize inherent or procedural hazards.

TI assumes no liability for applications assistance, customer product design, software performance, or infringement of patents or services described herein. Nor does TI warrant or represent that any license, either express or implied, is granted under any patent right, copyright, mask work right, or other intellectual property right of TI covering or relating to any combination, machine, or process in which such semiconductor products or services might be or are used.