

MOSFET

110A 250V

PDM1102H P2HM1102H

PDM1102H

P2HM1102H

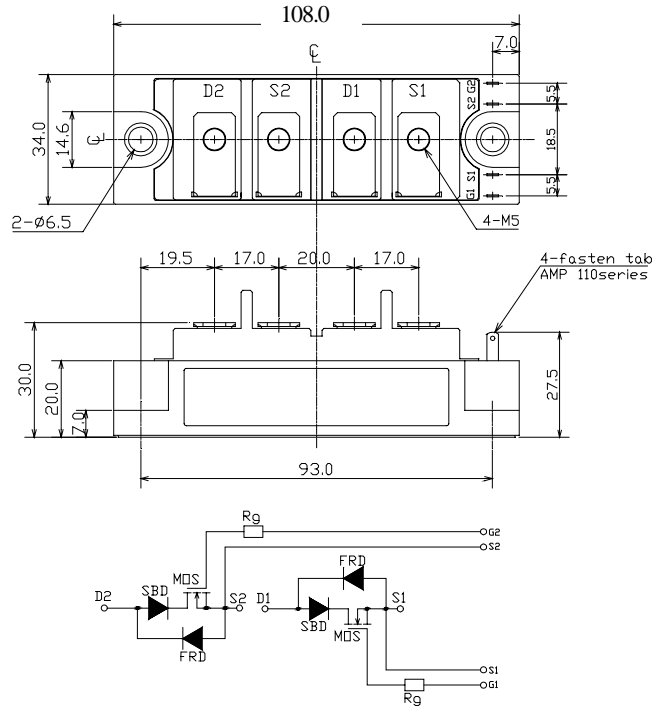
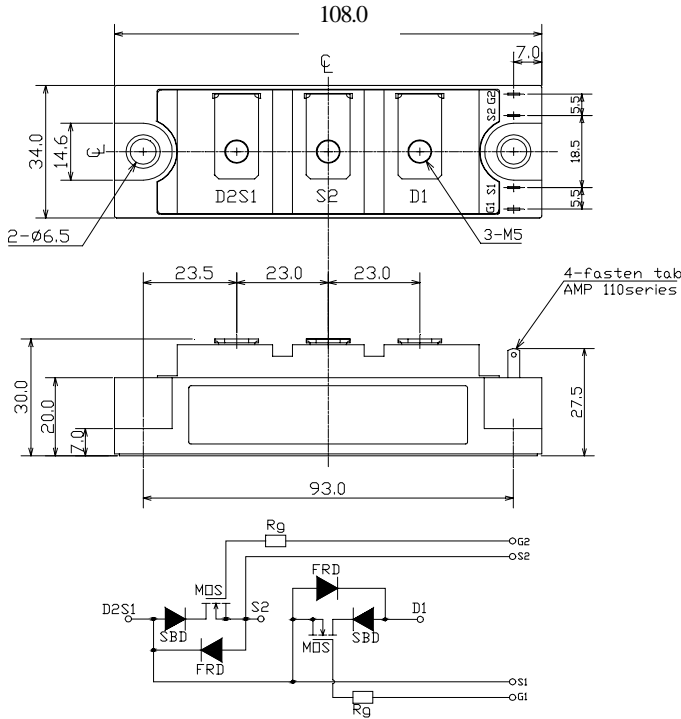

質量 Approximate Weight :220g

質量 Approximate Weight :220g

最大定格 Maximum Ratings

項目 Rating	記号 Symbol	耐压・クラス Grade		単位 Unit
		PDM1102H / P2HM1102H		
ドレイン・ソース間電圧 Drain-Source Voltage	V _{DSS}	250		V
		V _{GS} =0V		
ゲート・ソース間電圧 Gate-Source Voltage	V _{GSS}	± 20		V
ドレイン電流 (連続) Continuous Drain Current	I _D	Duty=50%	110 (T _C =25)	A
		D.C.	80 (T _C =25)	
パルスドレイン電流 Pulsed Drain Current	I _{DM}	220 (T _C =25)		A
全損失 Total Power Dissipation	P _D	420 (T _C =25)		W
動作接合温度範囲 Operating Junction Temperature Range	T _{jw}	- 40 ~ +150		
保存温度範囲 Storage Temperature Range	T _{stg}	- 40 ~ +125		
絶縁耐圧 RMS Isolation Voltage	V _{iso}	2000		V
		端子 - ベース間, AC1 分間 Terminals to Base, AC 1 min .		
締付トルク Mounting Torque	F _{tor}	3.0 (本体取付 Module Base to Heat sink)		N・m
		2.0 (ネジ端子部 Bus bar to Main Terminals)		

電気的特性 Electrical Characteristics (@Tc = 25 unless otherwise noted)

項目 Characteristic	記号 Symbol	条件 Condition	特性値(最大) Maximum Value			単位 Unit
			最小 Min.	標準 Typ.	最大 Max.	
ドレイン遮断電流 Zero Gate Voltage Drain Current	IDSS	VDS = VDSS, VGS = 0V			1	mA
		TJ = 125, VDS = VDSS, VGS = 0V			4	
ゲート・ソース間しきい値電圧 Gate-Source Threshold Voltage	VGS(th)	VDS = VGS, ID = 3mA	2	3.3	4	V
ゲート・ソース間漏れ電流 Gate-Source Leakage Current	IGSS	VGS = ±10V, VDS = 0V			0.3	μA
ドレイン・ソース間オン抵抗 (MOSFET部) Static Drain-Source On-Resistance	rDS(on)	VGS = 10V, ID = 55A		29	33	m
ドレイン・ソース間オン電圧 Drain-Source On-Voltage	VDS(on)	VGS = 10V, ID = 55A		2.2	2.4	V
順伝達コンダクタンス Forward Transconductance	gfg	VDS = 15V, ID = 55A		55		S
入力容量 Input Capacitance	Ciss			13		nF
出力容量 Output Capacitance	Coss	VGS = 0V VDS = 25V f = 1MHz		2.3		nF
帰還容量 Reverse Transfer Capacitance	Crss			0.36		nF
ターン・オン遅延時間 Turn-On Delay Time	tD(on)			140		ns
上昇時間 Rise Time	tr	VDD = 1/2VDSS ID = 55A		200		ns
ターン・オン遅延時間 Turn-Off Delay Time	tD(off)	VGS = -5V, +10V RG = 5		230		ns
下降時間 Fall Time	tf			80		ns

内部ダイオード定格・特性 Source-Drain Diode Ratings and Characteristics (@Tc = 25 unless otherwise noted)

項目 Characteristic	記号 Symbol	条件 Condition	特性値(最大) Maximum Value			単位 Unit
			最小 Min.	標準 Typ.	最大 Max.	
ソース電流 (連続) Continuous Source Current	IS	D. C.			80	A
パルスソース電流 Pulsed Source Current	ISM				220	A
ダイオード順電圧 Diode Forward Voltage	VSD	IS = 110A			1.4	V
逆回復時間 Reverse Recovery Time	trr	IS = 110A		75		ns
逆回復電荷 Reverse Recovery Charge	Qr	- dis/dt = 100A/μs		0.15		μC

熱抵抗特性 Thermal Characteristics

項目 Characteristic	記号 Symbol	条件 Condition	特性値(最大) Maximum Value			単位 Unit
			最小 Min.	標準 Typ.	最大 Max.	
熱抵抗 (接合部 - ケース間) Thermal Resistance, Junction to Case	Rth(j-c)	MOSFET			0.30	/W
		Diode			2.0	
接触熱抵抗 (ケース - 冷却フィン間) Thermal Resistance, Case to Heatsink	Rth(c-f)	サーマルコンパウンド塗布 Mounting surface flat, smooth, and greased			0.1	

定格・特性曲线

Fig. 1 Typical Output Characteristics

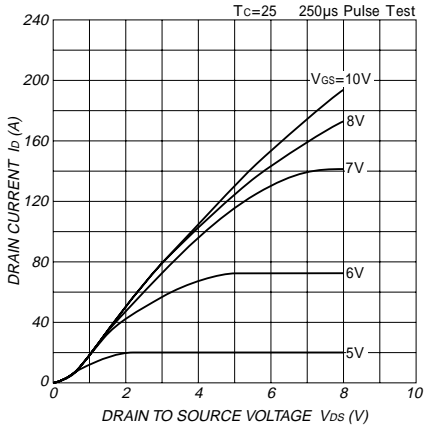

Fig. 4 Typical Capacitance Vs. Drain-Source Voltage

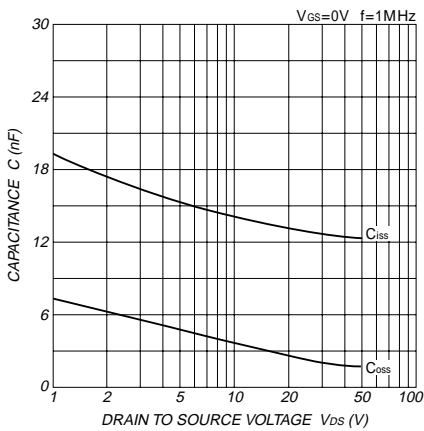

Fig. 7 Typical Switching Time Vs. Drain Current

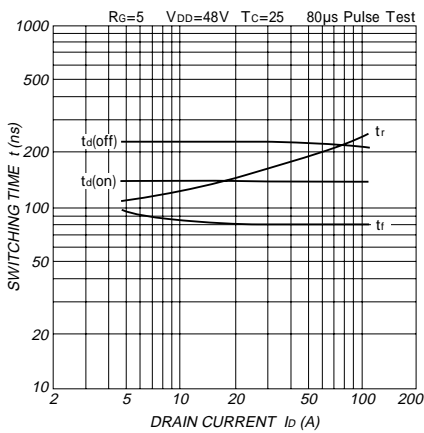

Fig. 10 Maximum Safe Operating Area

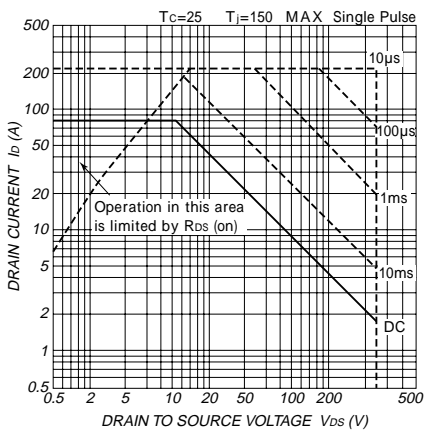

Fig. 2 Typical Drain-Source On-Voltage Vs. Gate-Source Voltage

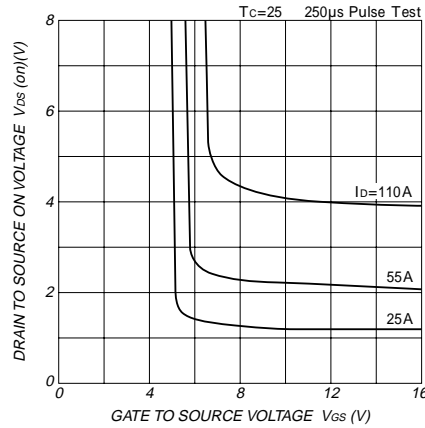

Fig. 5 Typical Gate Charge Vs. Gate-Source Voltage

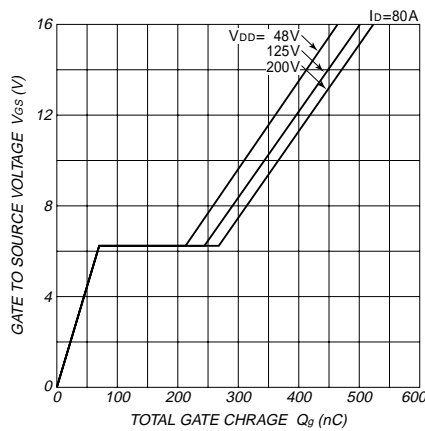

Fig. 8 Typical Source-Drain Diode Forward Characteristics

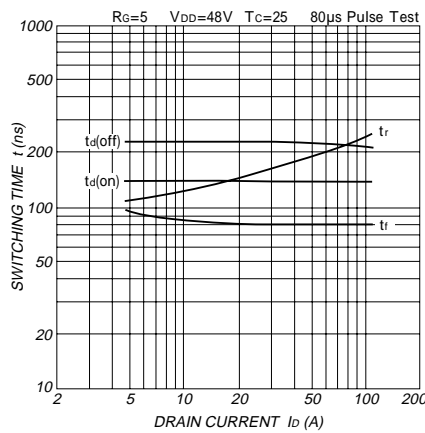

Fig. 11-1 Normalized Transient Thermal impedance(MOSFET)

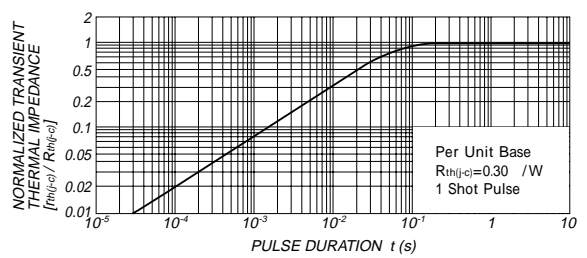

Fig. 11-2 Normalized Transient Thermal impedance(DIODE)

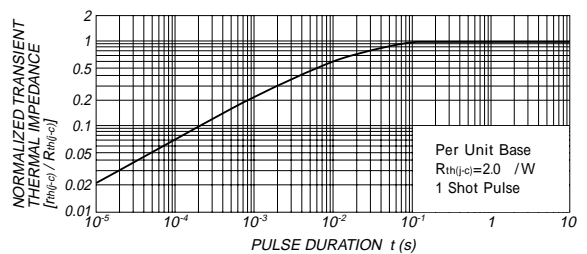

Fig. 3 Typical Drain-Source On Voltage Vs. Junction Temperature

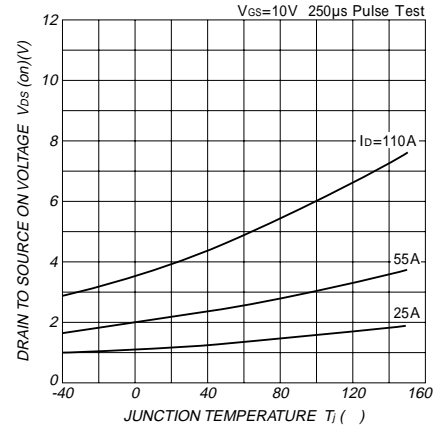

Fig. 6 Typical Switching Time Vs. Series Gate impedance

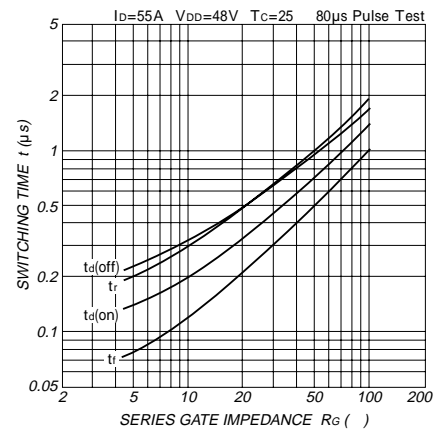

Fig. 9 Typical Reverse Recovery Characteristics

