

Document	
ECN No.	
Date of Issue	September 11, 1990
Status	Preliminary Specification
Application Specific Product	

NE/SA578

Unity gain level programmable low power compandor

DESCRIPTION

The NE/SA578 is a unity gain level programmable compandor designed for low power applications. The NE578 is internally configured as an expander and a compressor to minimize external component count.

The summing amplifiers of the NE578 have 600Ω drive capability and the inverting input of the compressor amplifier is accessible through Pin 9 for summing multiple external signals. Power Down/Mute function is active low and requires an open collector output logic configuration at Pin 8. If Power Down/Mute is not needed, Pin 8 should be left open. When the part is muted, supply current drops to 170μA at 3.6V. The NE578 is available in a 16-pin plastic DIP and SO packages.

FEATURES

- Operating voltage range: 1.8V to 7V
- Low power consumption (1.4mA @ 3.6V)
- 0dB level programmable (10mV_{RMS} to 1.0V_{RMS})
- Over 90dB of dynamic range
- Wide input/output swing capability
- Low external component count
- SA578 meets cellular radio specifications
- ESD hardened
- Power Down mode (I_{CC} = 170μA @ 3.6V)
- Mute function
- Multiple external summing capability
- 600Ω drive capability

APPLICATIONS

- High performance portable communications
- Cellular radio
- Cordless telephone
- Consumer audio
- Wireless microphones
- Modems
- Electric organs
- Hearing aids
- Automatic level control (ALC)

PIN CONFIGURATION

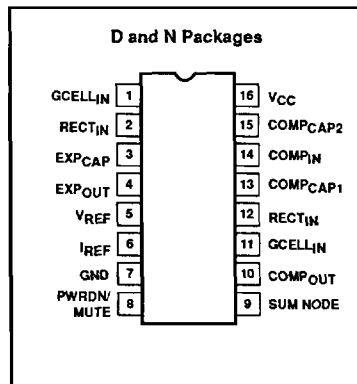

ORDERING INFORMATION

DESCRIPTION	TEMPERATURE RANGE	ORDER CODE
16-Pin Plastic DIP	0 to +70°C	NE578N
16-Pin Plastic SO	0 to +70°C	NE578D
16-Pin Plastic DIP	-40 to +85°C	SA578N
16-Pin Plastic SO	-40 to +85°C	SA578D

Unity gain level programmable low power compandor

NE/SA578

BLOCK DIAGRAM and TEST AND APPLICATION CIRCUIT

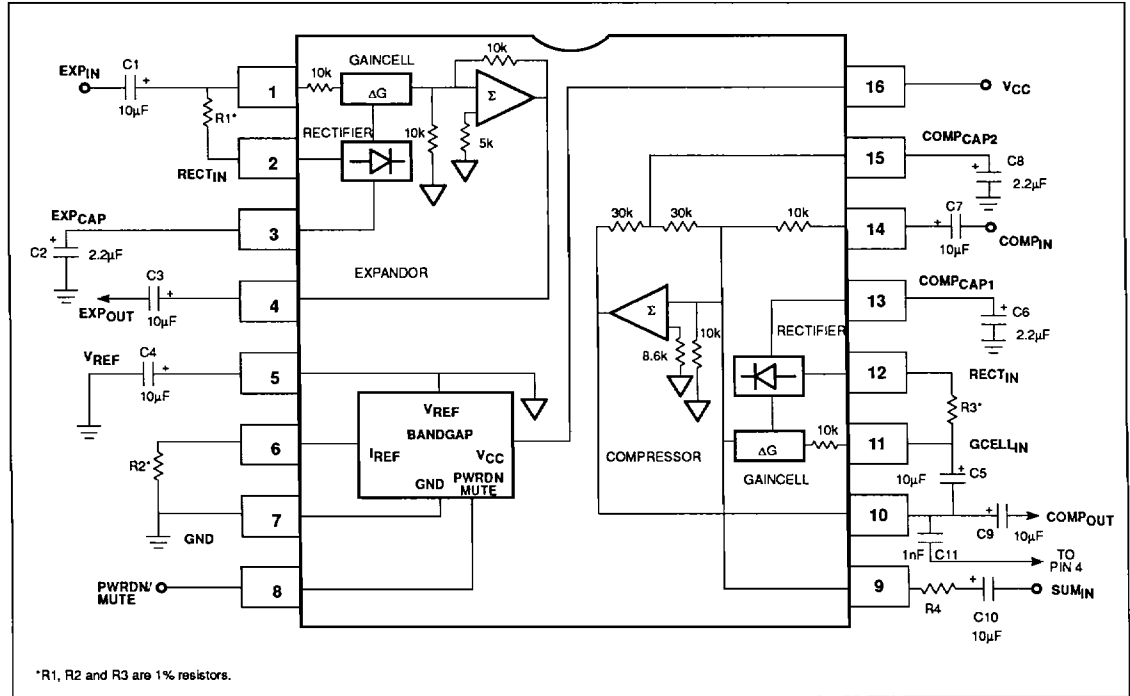

Unity gain level programmable low power compandor

NE/SA578

ABSOLUTE MAXIMUM RATINGS

SYMBOL	PARAMETER	RATING		UNITS
		NE578	SA578	
V _{CC}	Supply voltage	8	8	V
T _A	Operating ambient temperature range	0 to +70	-40 to +85	°C
T _{STG}	Storage temperature range	-65 to +150	-65 to +150	°C
θ _{JA}	Thermal impedance	DIP 90 SO 125	90 125	°C/W °C/W

ELECTRICAL CHARACTERISTICS

T_A = 25°C, V_{CC} = 3.6VDC, compandor 0dB level = -20dBV = 100mV_{RMS}, output load R_L = 10kΩ, Freq = 1kHz, unless otherwise specified. R1, R2 and R3 are 1% resistors.

SYMBOL	PARAMETER	TEST CONDITIONS	LIMITS			UNITS
			NE/SA578			
			MIN	TYP	MAX	
V _{CC}	Supply voltage ¹		2	3.6	7	V
I _{CC}	Supply current	No signal, R ₂ = 100kΩ		1.4	2	mA μA
	operating power down			170		
V _{REF}	Reference voltage ²	V _{CC} = 3.6V	1.7	1.8	1.9	V
R _L	Summing amp minimum output load			600		Ω
THD	Total harmonic distortion	1kHz, 0dB, BW = 3.5kHz		0.1	1.0	%
E _{NO}	Expander output noise voltage	BW = 20kHz, R _S = 0Ω			20	μV
0dB	Unity gain level	0dB at 1kHz	-1.0		1.0	dB
	Programmable range ³	R1 = R3 = 18.7kΩ, R2 = 24.3kΩ		0		dBV
		R1 = R3 = 22.6kΩ, R2 = 100kΩ		-10		dBV
		R1 = R3 = 7.15kΩ, R2 = 100kΩ		-20		dBV
		R1 = R3 = 1.33kΩ, R2 = 200kΩ		-40		dBV
V _{OS}	Output voltage offset	No signal	-150		150	mV
	Expander output DC shift	No signal to 0dB	-100		100	mV
	Tracking error relative to 0dB output		-1.0		1.0	dB
	Crosstalk, COMP to EXP	1kHz, 0dB, C _{REF} = 10μF		-80	-65	dB
V _O	Output swing low			0.2		V
	Output swing high			V _{CC} - 0.2		V
	Power Down/Mute low level		0		0.4	V
	Power Down/Mute input current	Pin 8 grounded		-65		μA

NOTE:

1. Operation down to V_{CC} = 1.8V is possible, see application note AN1762.
2. Reference voltage, V_{REF}, is typically at 1/2 V_{CC}.
3. Unity gain level can be adjusted CONTINUOUSLY between -40dBV = 10mV_{RMS} and 0dBV = 1.0V_{RMS}. For details see application note AN1762.