

Connector

PRODUCT SPECIFICATION

L4NF

N for LDF4-50A, Low Density Foam Dielectric Cable

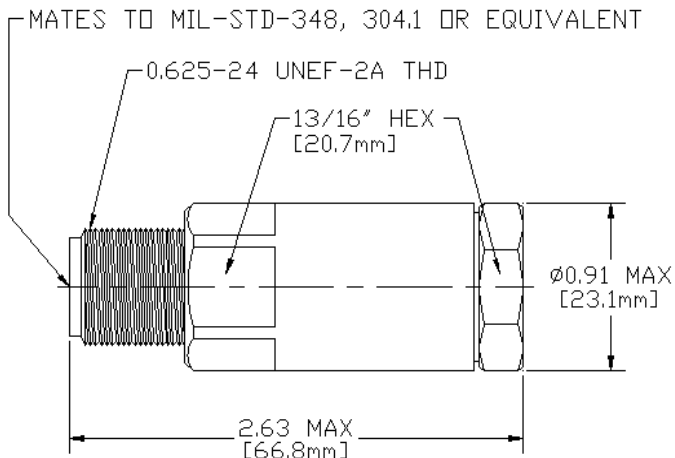

CHARACTERISTICS

Components

O-Ring	Silicone Rubber
O-Ring	Silicone Rubber
Inner Contact	Beryllium Copper Silver Plate
Insulator	PTFE
Clamp Nut	Brass Benzotriazole Treatment Process
Body	Brass Benzotriazole Treatment Process

Electrical

Recommended Maximum Operating Frequency, GHz	7.0	Connector Limited
Peak Power, max, kW	10.0	Connector Limited
Average Power, max, kW @ 900 MHz	0.60	Connector Limited
dc Test Maximum Voltage	2,000	Connector Limited
RF Operating Voltage, max, VRMS	707	Connector Limited

Customer Support Center:

From North America: 1-800-255-1479
International: +1-708-873-2307

www.andrew.com

This Specification Sheet is for reference only and is subject to change without notice.

Copyright © 2002 by Andrew Corporation, Printed in U.S.A.
December 19, 200

Connector

PRODUCT SPECIFICATION

L4NF

N for LDF4-50A, Low Density Foam Dielectric Cable

Electrical

RF High Potential, max, VRMS	990	Connector Limited
Inner Contact Resistance	2.00	MilliOhms
Outer Contact Resistance	0.30	MilliOhms
Insulation Resistance, min, MOhms	5,000	Connector Limited
Nominal Impedence, Ohms	50	
Cable Impedence, Ohms	50	
Insertion Loss, max, dB	0.05 $\sqrt{\text{frequency(GHz)}}$	
Connector Return Loss, dB		
0 - 0.88 GHz	37	
0.88 - 1.8 GHz	30	
1.8 - 5.3 GHz	27	
5.3 - 6.2 GHz	26	
6.2 - 7 GHz	23	

Mechanical

Inner Attachment Method	Solder on
Outer Attachment Method	Self flare
Pressurizable	No
Coupling Nut Retention Force, N (lb)	445.0 (100.0)
Method	MIL-C-39012C 3.25, 4.6.22
Minimum Coupling Nut Torque, N-m (lb-in)	2.2 (19.9)
Minimum Connector Retention Tensile Force, N (lb)	890.0 (200.1)
Minimum Connector Retention Torque, N-m (lb-in)	5.4 (47.8)
Attachment Durability (Number of cycles)	25
Interface Durability (Number of cycles)	50

Environmental

Moisture Resistance Test	MIL-STD-202, Method 106
Mechanical Shock Test	MIL-STD-202, Method 213, Condition I
Corrosion Test	MIL-STD-202, Method 101, Condition B
Thermal Shock Test	MIL-STD-202, Method 107, Cond A-1, -57°C to 100°C
Vibration Test	MIL-STD-202, Method 204, Condition B
Operating Temperature Range, °C	-40 to 85
Storage Temperature Range, °C	-40 to 85
Water Jetting Test, unmated connectors	

Customer Support Center:

From North America: 1-800-255-1479
International: +1-708-873-2307

www.andrew.com

This Specification Sheet is for reference only and is subject to change without notice.

Copyright © 2002 by Andrew Corporation, Printed in U.S.A.
December 19, 200